

# Goulds ICB

Close-Coupled Chemical Process Pumps



# ICB

## Close-Coupled Chemical Pumps

- Capacity to 450 m<sup>3</sup>/h (1980 USGPM)
- Heads to 150 m (492 ft)
- Temperature Range -40°C to +140°C (-40°F to +280°F)
- Pressures to 16 bar (235 Psig)
- Inlet Pressures up to 6 bar (87 Psig)

## Material of Construction

- Ductile Iron (07.7043)
- Stainless Steel (1.4408)
- Duplex Stainless Steel (1.4517)

## Performance Features

### Extended Pump Reliability

- Patented “Cyclone” seal chamber extends seal life.
- Enclosed impeller reduces trust loads for extended seal and motor life.
- Heavy duty cast casing provides corrosion allowance and is resistant to flange loads.

### Reduces Maintenance Costs

- Precision machined fits eliminate alignment during installation.
- Couplings and Baseplates are not necessary reducing capital costs.
- Optional wear ring renew pump performance and extend pump life.

## Markets - Applications

- Chemical Process
- Pharmaceutical
- Food and Beverage Processing
- Steel Production
- Automotive
- Marine / Sea Water
- Water Supply and Cooling Water
- Water Treatment / Purification
- OEM

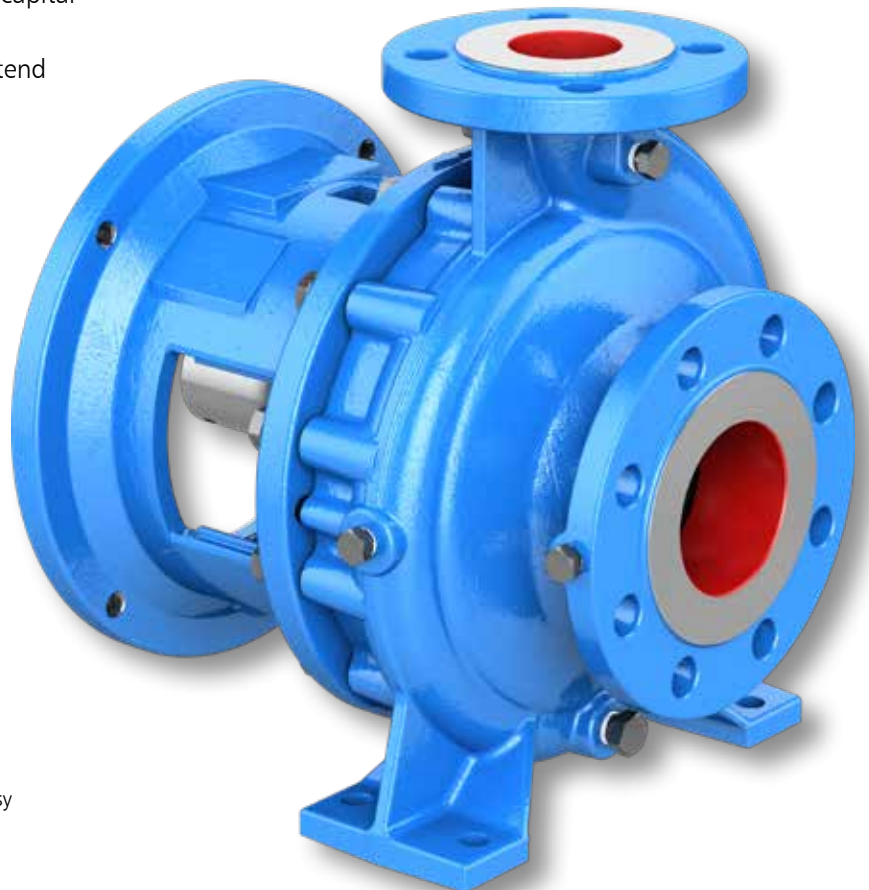

The ICB is a Compact, Yet Durable Chemical Process Pump  
Designed to Handle Liquids Ranging from Water to Mild Corrosives

Hydraulic Components Comply with ISO 2858 and DIN 24256 for Easy  
Integration to Industrial Process Piping Systems

# 50 Hz Performance

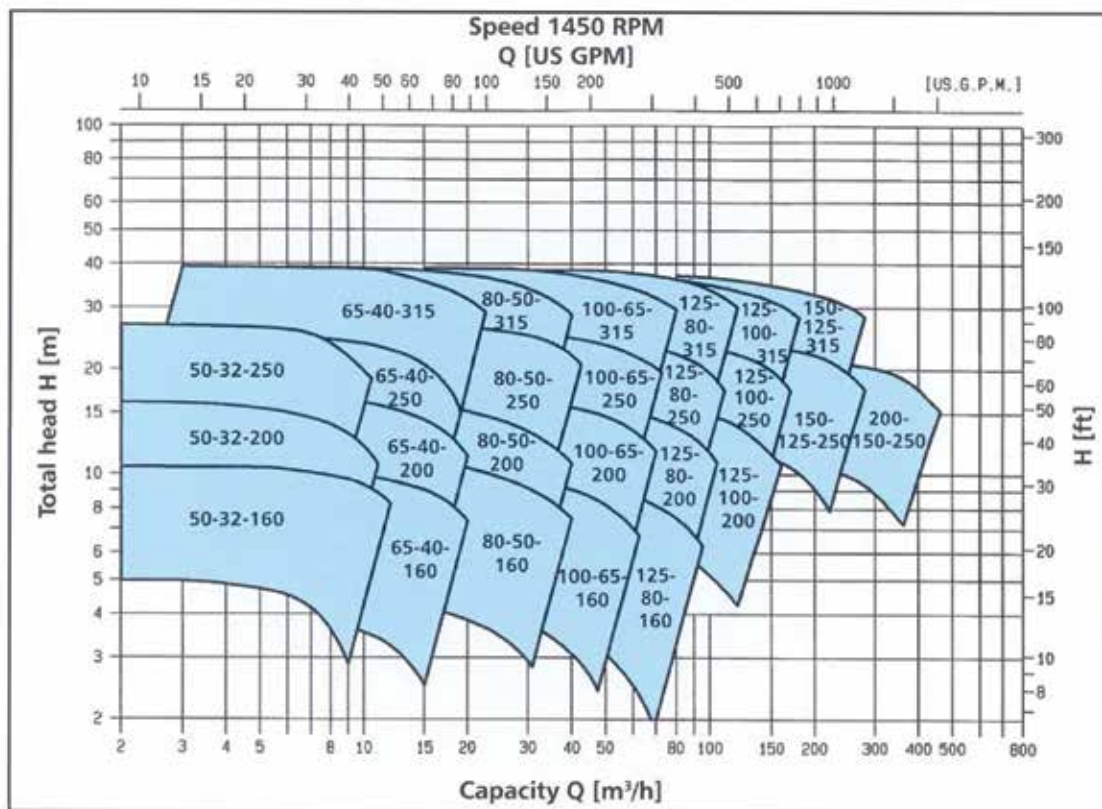
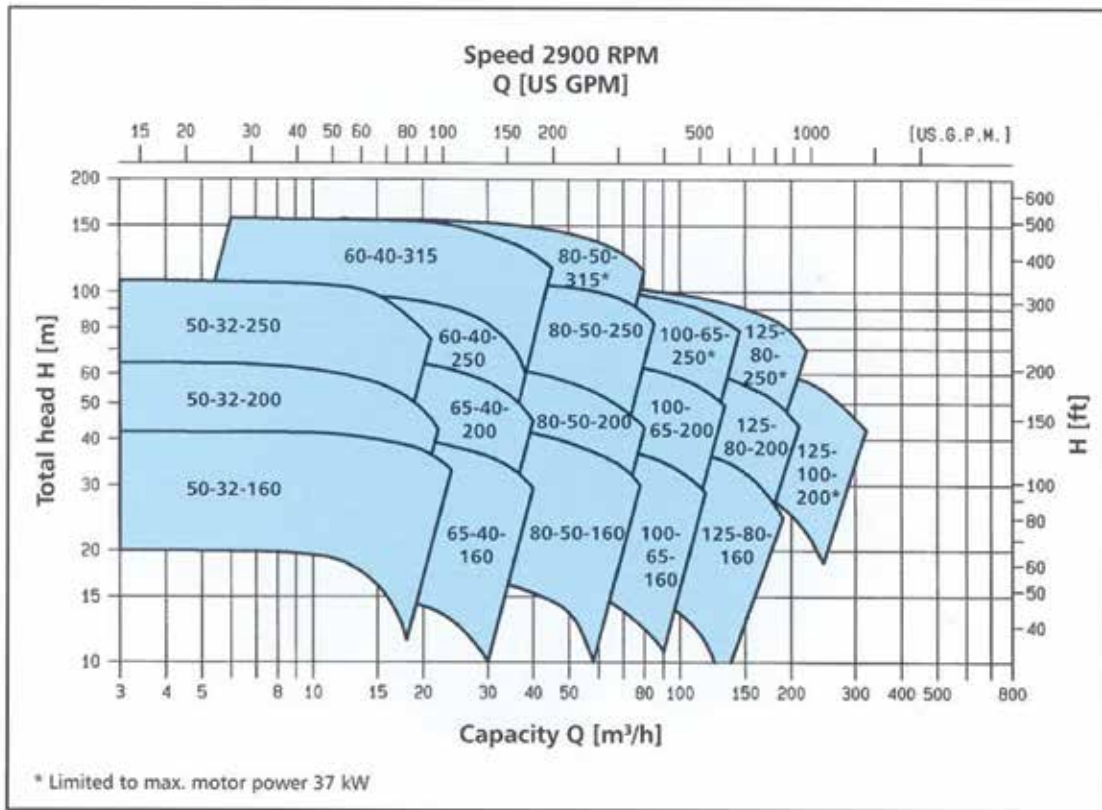



# ICB

## Value Packed Features Engineered for Reliability

### MOTOR LANTERN

- Precision machined fits maintained alignment between pump end and motor eliminating costly pre-alignment during motor installation
- Couplings and baseplates are not required reducing capital costs
- Compact, space saving arrangement ideal for OEM or space constrained installations

### STUB SHAFT

- Rigid one piece design eliminates tolerance stack-ups resulting in truer running seal faces for extended seal life
- Standard duplex SS (1.4462) construction for maximum corrosion resistance

### ENGINEERED SEAL CHAMBER

- Patented "Cyclone" seal chamber keeps solids and vapors out of the seal area for extended life
- Tapered Bore design enhances lubrication and cooling of seal faces often eliminating the need for external flush connections
- Can be fitted with standard DIN 24960 L<sub>1ku</sub> seals

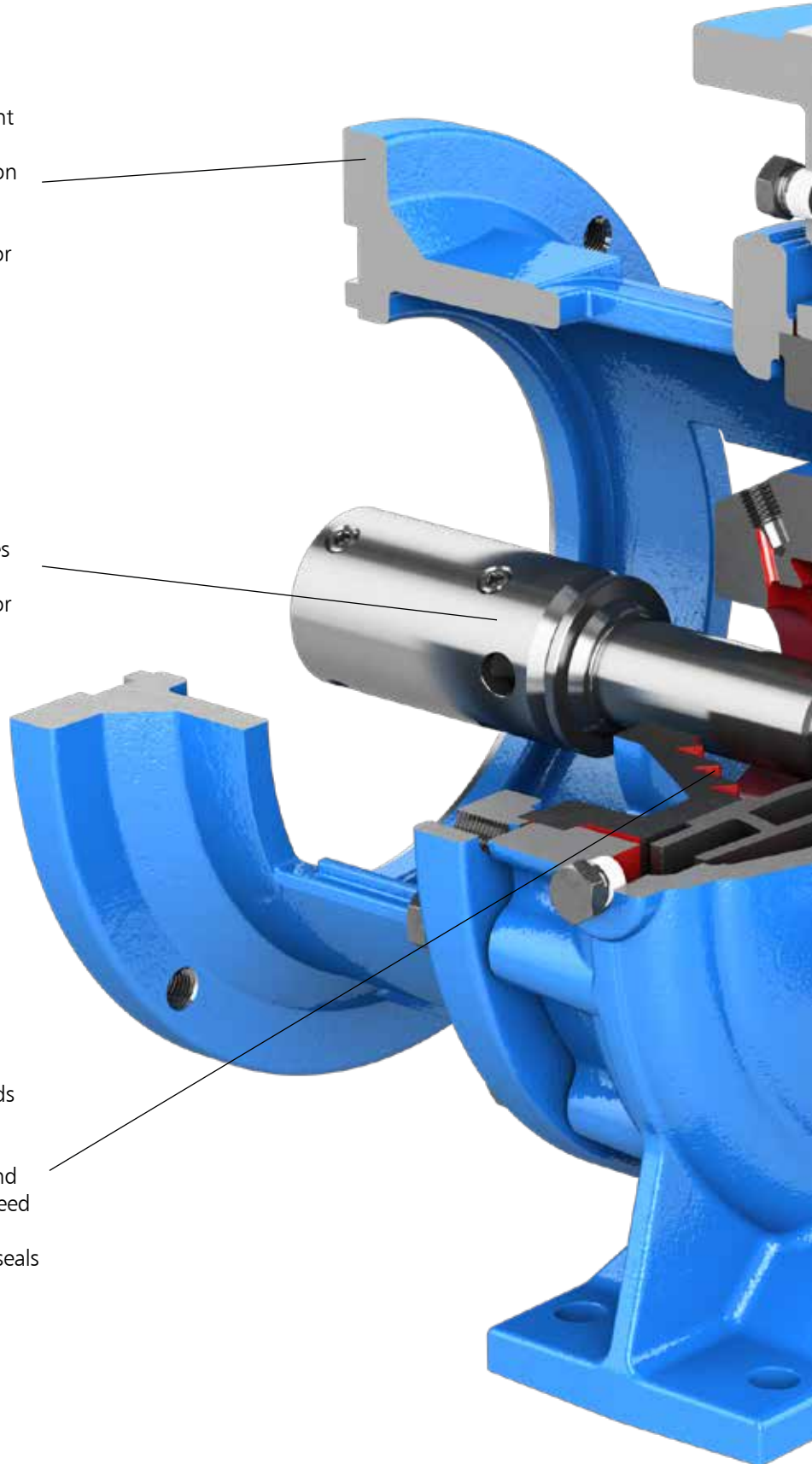

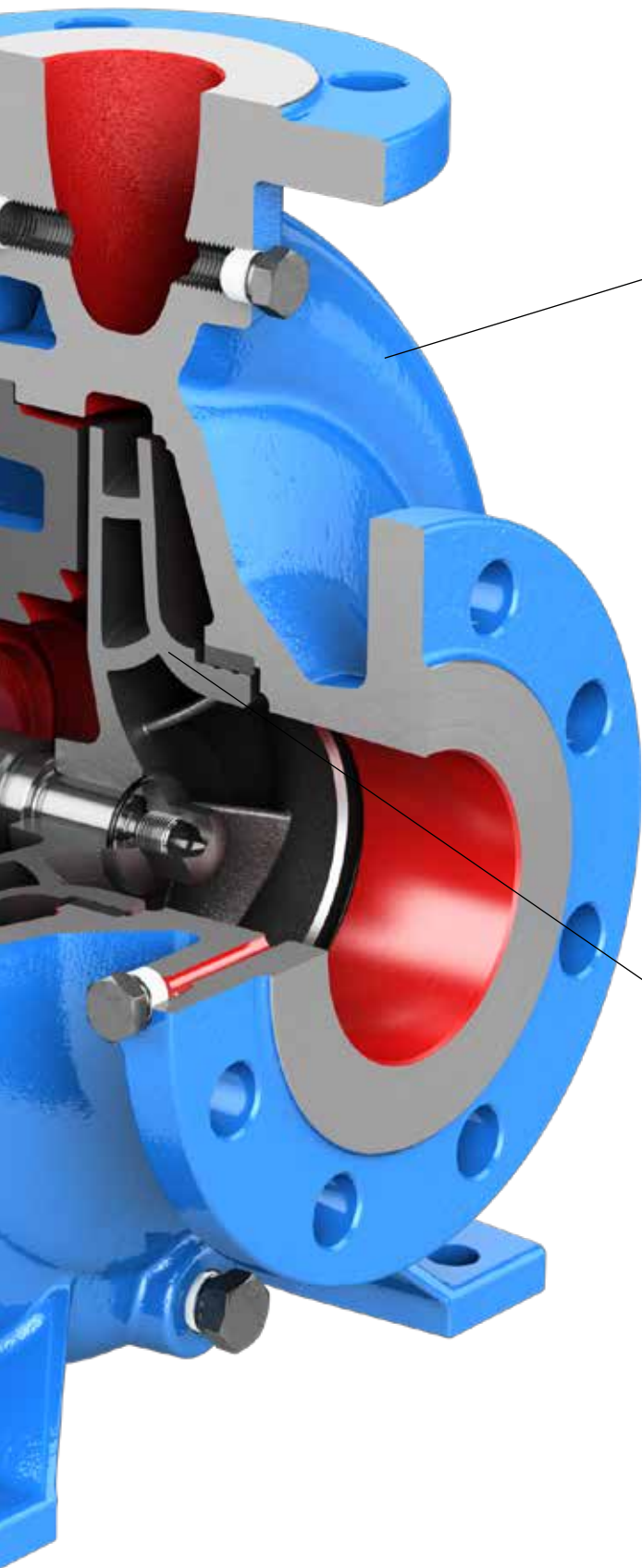

#### HEAVY DUTY CASING

- Casted heavy duty, foot supported design provides maximum resistance to pipe loads
- Minimum 3 mm corrosion allowance maximizes pump life
- Standard 3/8"-NPT casing drain for safe and simple maintenance
- ISO 2858 dimensions for easy installation in all systems

#### IMPELLER

- Precision cast, enclosed impeller design for maximum performance and low NPSHr
- Back vanes or balance holes reduce axial thrust and seal pressures for extended seal and motor life
- Key driven to prevent spin offs caused by mis-wiring
- Optional wear rings renew pump performance and extend pump life

# Parts List and Material of Construction

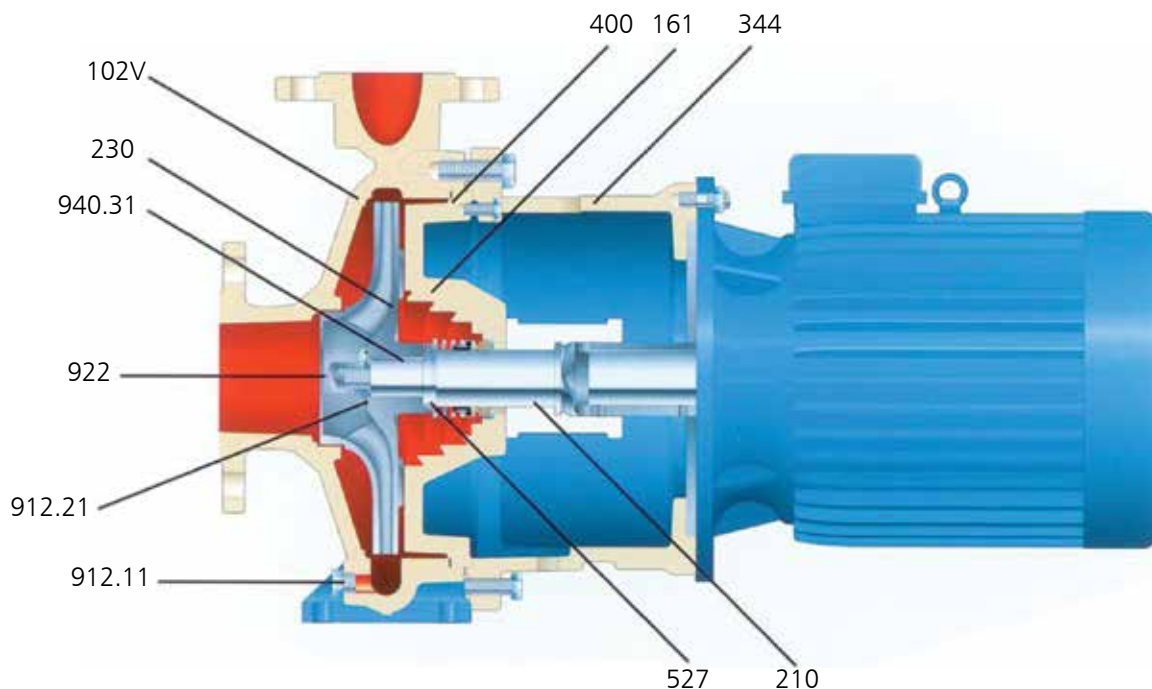

| Item Number | Part Name            | Ductile Iron (NL)         | DI/316ss (VL) | 316ss (VV) | Duplex SS (WW) |
|-------------|----------------------|---------------------------|---------------|------------|----------------|
| 102 V       | Casing               | Ductile Iron              |               | 316ss      | Duplex SS      |
| 161         | Seal Chamber         | Ductile Iron              |               | 316ss      | Duplex SS      |
| 210         | Stub Shaft           | Duplex 1.4462             |               |            |                |
| 230         | Impeller             | Cast Iron                 | 316ss         |            | Duplex SS      |
| 344         | Motor Lantern        | Ductile Iron              |               |            |                |
| 400         | Case Gasket          | Non-Asbestos Aramid Fiber |               |            |                |
| 527         | Fixing Ring          | Duplex SS (1.4462)        |               |            |                |
| 912.11      | Case Drain Plug      | 316ss                     |               |            |                |
| 912.21      | O-ring, Impeller Nut | Teflon                    |               |            |                |
| 922         | Impeller Nut         | Duplex SS                 |               |            |                |
| 940.31      | Impeller Key         | Duplex SS (1.4462)        |               |            |                |

|                 | IC-B Standard    | Approximate Equivalent |                   |
|-----------------|------------------|------------------------|-------------------|
|                 |                  | DIN                    | ASTM              |
| Cast Iron       | EN-GJL-250       | 0.6025                 | A48 Class 35B     |
| Ductile Iron    | EN-GJS-400-18-LT | 0.7043                 | A536 Gr. 60-40-18 |
| Stainless Steel | 1.4408           | 1.4408                 | A743 CF8M         |
| Duplex SS       | 1.4517           | 1.4517                 | A744 CD4MCu       |

## Engineered for Chemical Process Reliability yet Compact and Versatile for Industrial or OEM Service

### Patented “Cyclone” Seal Chamber

Keeps solids and vapors out of the seal environment for extended life

- A Tapered Bore design enhanced with cast helical grooves which act to keep solids and vapors out of the sealing area
- Increased radial clearance and volume for improved cooling of seal faces
- Self-venting design eliminates the build up of vapors in the seal area while simplifying pump start-ups
- Can be fitted with any DIN 24960 L<sub>1ku</sub> mechanical seal or with a quenched seal arrangement

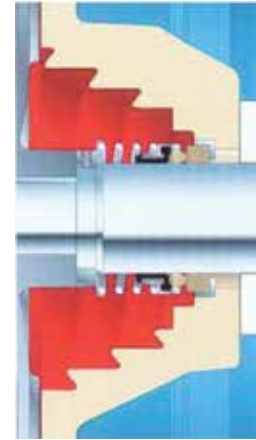

### High Efficiency, Enclosed Impeller Design

Engineered performance with low hydraulic loads

- Enclosed impeller design featuring back vanes or rear ring fits Act to reduce hydraulic thrust loads for extended seal and bearing life
- Precision cast, enclosed impellers provide high efficiency and low NPSHr for reduced operating cost and smooth operation
- Key driven to stub shaft to prevent start-up failures resulting from mis-wiring
- Optional wear ring re-nre pump performance and extended service life

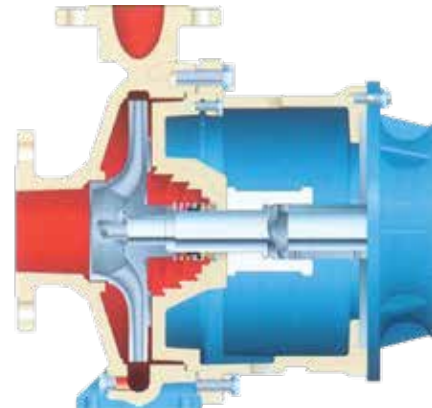

### Economical, Space Saving Design

Simplifies installation and reduces cost

- Precise mounting fits maintain pump / motor alignment eliminating alignment cost during installation
- Coupling cost and baseplate cost eliminated
- Duplex SS (1.4462) stub shaft mounts to standard IEC (B5) motors
- Pump motor “Foot Print” reduced 30%, ideal for OEM or space contained installations



# Locations



For more information Please Visit:  
[www.gouldspumps.com](http://www.gouldspumps.com) | [www.ittproservices.com](http://www.ittproservices.com)



— An ITT Brand

240 Fall Street  
Seneca Falls, NY 13148  
Phone: 315.568.2811  
Fax: 315.568.2418  
[www.gouldspumps.com](http://www.gouldspumps.com)

© 2022 ITT Goulds Pumps Inc.

B.ICB.en-US.2022-01