

# Goulds IC i-FRAME® Series

ISO process pump with i-ALERT Patented  
Intelligent Monitoring



# IC i-FRAME® Series

## Worldwide Solutions for Process Pumping and Controls



Goulds Pumps IC family of ISO chemical process pumps is designed in accordance with ISO 5199 and ISO 2858, making it ideal for worldwide chemical or industrial process applications. The IC pump range includes:

- 34 hydraulic sizes
- Flows up to 450 m<sup>3</sup>/h (1980 GPM)
- Heads up to 160m (514 Feet)
- Temperatures from -40°C to 280°C (-40°F to 530°F)
- Pressures up to 25 Bar (360 PSI)

The IC series represents over 150 years of process pump experience to define a solution which truly reduces your pumping Life Cycle Cost. Utilizing a modular design, the IC pump offers broad hydraulic coverage while minimizing the number of pump components for reduced maintenance and inventory cost.

The IC series consists of multiple pump configurations, which have been engineered by ITT hydraulic specialists from Goulds Pumps, to meet both the pumping and environmental needs of customers in the Process Industry. Included in the range is:

- IC - 16 Bar, mechanically sealed version for most process fluid pumping.
- ICP - 25 Bar, centerline mounted unit for high pressure and high temperature applications.
- ICB - compact, close-coupled design for economical, space-saving service.
- ICM - magnetic drive, sealless arrangement for the handling of hazardous or sensitive liquids.

ITT Goulds proven pump hydraulic designs utilize precision cast, enclosed impeller for maximum efficiency, low NPSH and reduced hydraulic loads. In addition, all mechanically sealed pumps have been engineered with our patented Cyclone Seal Chamber, a feature proven to provide the optimum sealing environment for extended seal life, critical in reducing Life Cycle Cost.



Installations  
Worldwide

The IC series is available in a comprehensive range of materials which include ductile iron, 316 Stainless Steel, Duplex Stainless Steel, Alloy 20, Hastelloy B and C, Nickel, Inconel and Titanium.

# Goolds Reliability

## Long-term Reliable Performance Means Lower Life-Cycle Costs.

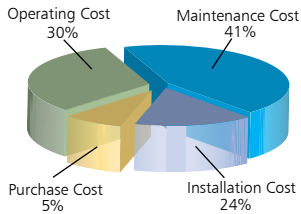

Only 5% is the initial pump cost

When selecting a chemical process pump, look for the design features that help lower maintenance costs as well as operating and installation costs. Design features that maximize reliability and ensure long-term maintainable hydraulic performance help lower the “total cost” of pump ownership. In a typical process pump, over a 20 year pump life, 95% of the total costs are maintenance, operation and installation costs.

## The Keys to Reliable Performance

### The “Cyclone” Seal Chamber and a Heavy Duty Bearing Frame.

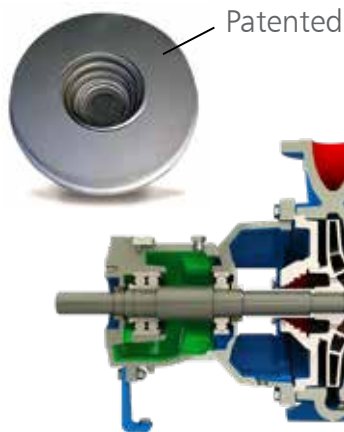

#### FACT:

The number one cause of pump downtime is failure of the shaft seal. Typically, seal failures are the result of an unfavorable seal environment such as poor heat dissipation, poor lubrication or operation in the presence of solids or vapors.

Patented cyclone seal chamber design maximizes seal life.

- A tapered bore design enhanced with a helical groove removes suspended solids away from mechanical seal components resulting in extended seal life.
- Increased radial clearance and volume provides improved cooling for extended seal life.
- Self drain and Self venting design simplifies start-up procedures and eliminates a build-up of vapors in the seal area.
- Patented design has been rigorously tested for reliable results.

## Optimized Oil Sump Design

Internal sump geometry is optimized for longer bearing life. Sump size increased by 10% – 20% results in better heat transfer and cooler bearings. Contoured design directs contaminants away from bearings, to the magnetic drain plug for safe removal.

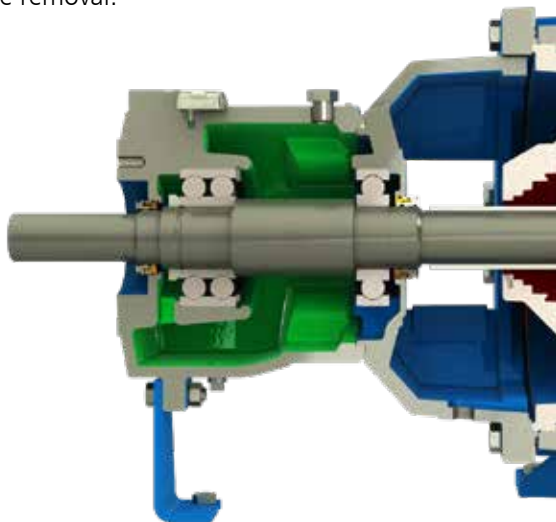

#### FACT:

The second largest cause of pump downtime is bearing failures. Over 90% of all pump bearing failures are the result of inadequate or contaminated lubrication.

Rigid bearing frame extends pump life.

- Large capacity oil sump results in cooler, cleaner oil. The Model IC ISO chemical pump has the largest sump in its class!
- Heavy duty bearing sized for L10 bearing life in excess of 17,500 hours.
- Rigid, stainless steel shaft resists corrosion while maintaining shaft deflections below 0.05 mm.
- Hybrid labyrinth oil seals maintain clean oil sump.
- O-ring seal between frame and lantern ensures clean oil environment.

# IC i-FRAME® Process Pumps

## i-ALERT® CONDITION MONITOR (U.S. Patent 8,154,417)

Constantly measures vibration and temperature at the thrust bearing. Colored LED's indicate general pump health. Provides early warning of improper operation before catastrophic failure occurs.

(i-ALERT® 2 Bluetooth Equipment Health Monitor option available. See page 11 for more information.)

## INPRO VBXX-D HYBRID LABYRINTH SEALS

Prevents premature bearing failure caused by lubricant contamination or loss of oil. Stainless steel rotors for optimal performance in corrosive environments.

## HEAVY DUTY SHAFT AND BEARINGS

Rigid shaft designed for minimum deflection at seal faces—less than 50  $\mu\text{m}$ . Bearings sized for long life under tough operating conditions. Available with or without shaft sleeve.

## PREMIUM SEVERE-DUTY THRUST BEARINGS

Premium bearings using improved tolerance and cleaner steel provide reduced assembled runout and longer bearing life.

## ONE - INCH BULL'S EYE SIGHT GLASS

Assures proper oil level critical to bearing life. Can be mounted on either side of pump for installation flexibility.

## OPTIMIZED OIL SUMP DESIGN

Increased oil capacity provides better heat transfer for reduced oil temperature. Bearings run cooler and last longer. Contaminants directed away from bearings to magnetic drain plug.

## MAGNETIC DRAIN PLUG

Standard magnetic drain plug helps protect bearings and prolong life.

## i-FRAME® POWER END

Designed for reliability and extended pump life, backed with a 5-year warranty.

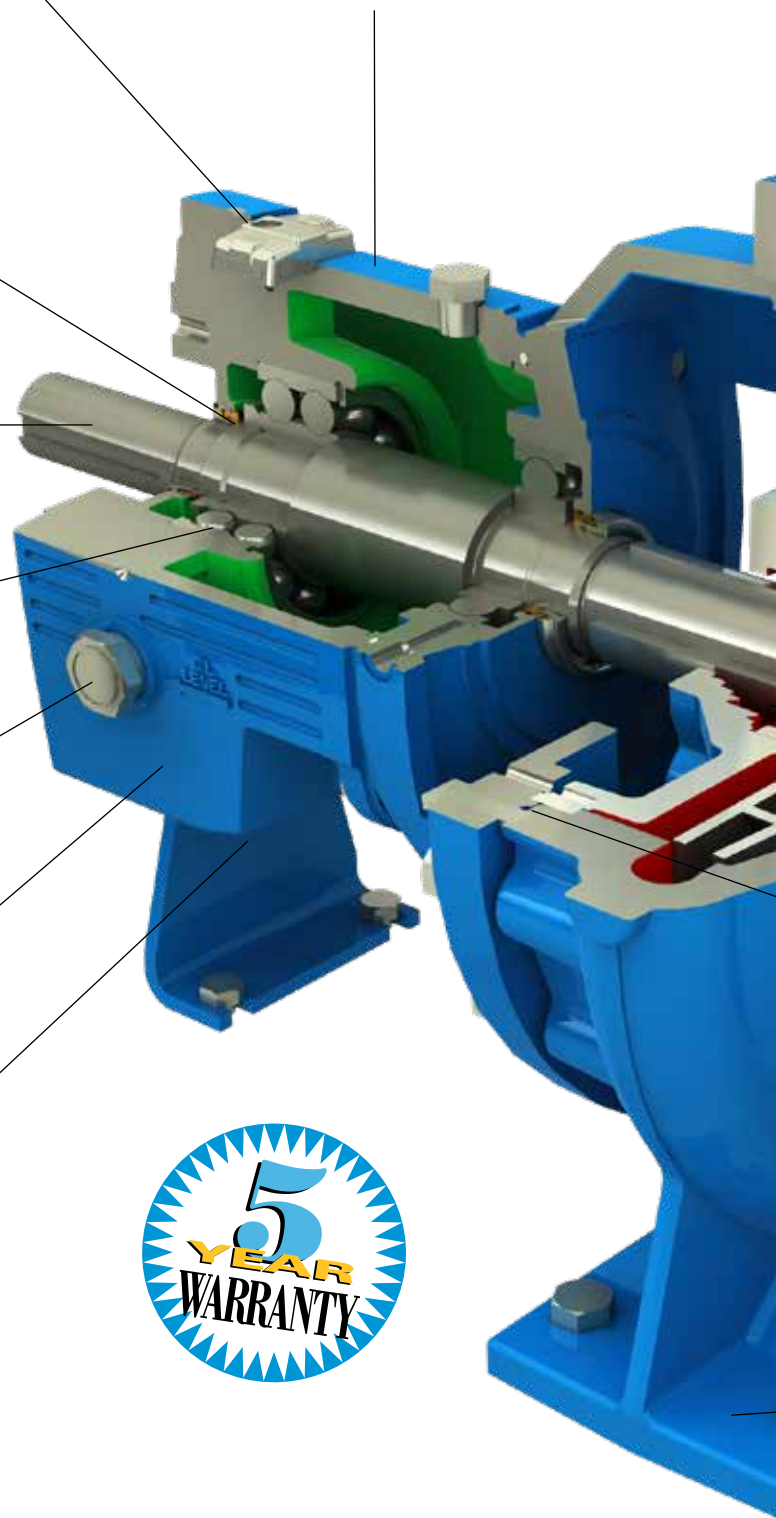

**DUCTILE IRON FRAME ADAPTER**  
Material strength equal to carbon steel for safety and reliability.

### CASING

- Heavy duty, top centerline discharge casing with integral cast feet provides maximum resistance to pipe loads for improved seal and bearing life
- Minimum 3mm corrosion allowance maximizes pump life for corrosive and erosive applications
- Back pull out design makes maintenance activities safe and simple
- Standard 3/8" NPT casing drain for safe maintenance
- Renewable wear ring maintains pump performance over the life of the pump (optional)

### IMPELLER

- Precision-cast enclosed impeller design provides maximum efficiency and optimum NPSH performance
- Preferred by ISO 5199 for maximum mechanical seal life
- Standard back vanes or balance holes reduce axial thrust and seal chamber pressures for extended bearing and seal life
- Key driven for maximum reliability; eliminates spinoffs due to reverse rotation during start-up

### SEALING FLEXIBILITY

Wide range of sealing arrangements available to meet service conditions. Engineered seal chambers improve lubrication and heat removal (cooling) of seal faces for extended seal life and pump uptime.

### POSITIVE SEALING

Fully confined gasket at casing joint protects alignment fit from liquid, makes disassembly easier.

### RIGID CASING FEET

Reduce effects of pipe loads on shaft alignment; pump vibration reduced.

Conforms to ISO 5199 and ISO 2858 for maximum reliability and ease of installation.  
Superior hydraulic design for maximum performance and extended mechanical reliability.

# Goulds Patented i-FRAME® Power Ends

## Extended Pump Life Through Intelligent Design

Goulds *i-FRAME* Power Ends are the result of close to 170 years of design experience, customer interaction, and continuous improvement. Customers get extended Mean Time Between Failure (MTBF) and lower life cycle costs (LCC) ... guaranteed!

### 1 Patented i-ALERT® Condition Monitor



The heart of the *i-FRAME*, the *i-ALERT* condition monitor unit continuously measures vibration and temperature at the thrust bearing and automatically

indicates when pre-set levels of vibration and temperature have been exceeded, so that changes to the process or machine can be made before failure occurs. A visual indication of pump health makes walk-around inspections more efficient and accurate. The result is a more robust process to monitor and maintain all your ISO and ANSI pumps so that your plant profitability is maximized.

(*i-ALERT*®2 Bluetooth Equipment Health Monitor option available. See page 11 for more information.)

### 2 Inpro VBXX-D Hybrid Bearing Isolators

Most bearings fail before reaching their potential life. They fail for a variety of reasons, including contamination of the lubricant. INPRO VBXX-D has long been considered the industry standard in bearing lubricant protection. The *i-FRAME* now improves upon that design by offering stainless steel rotors, for maximum protection against contaminants and the corrosive effects of seal leakage or environmental conditions. These seals are non-contacting and do not wear.

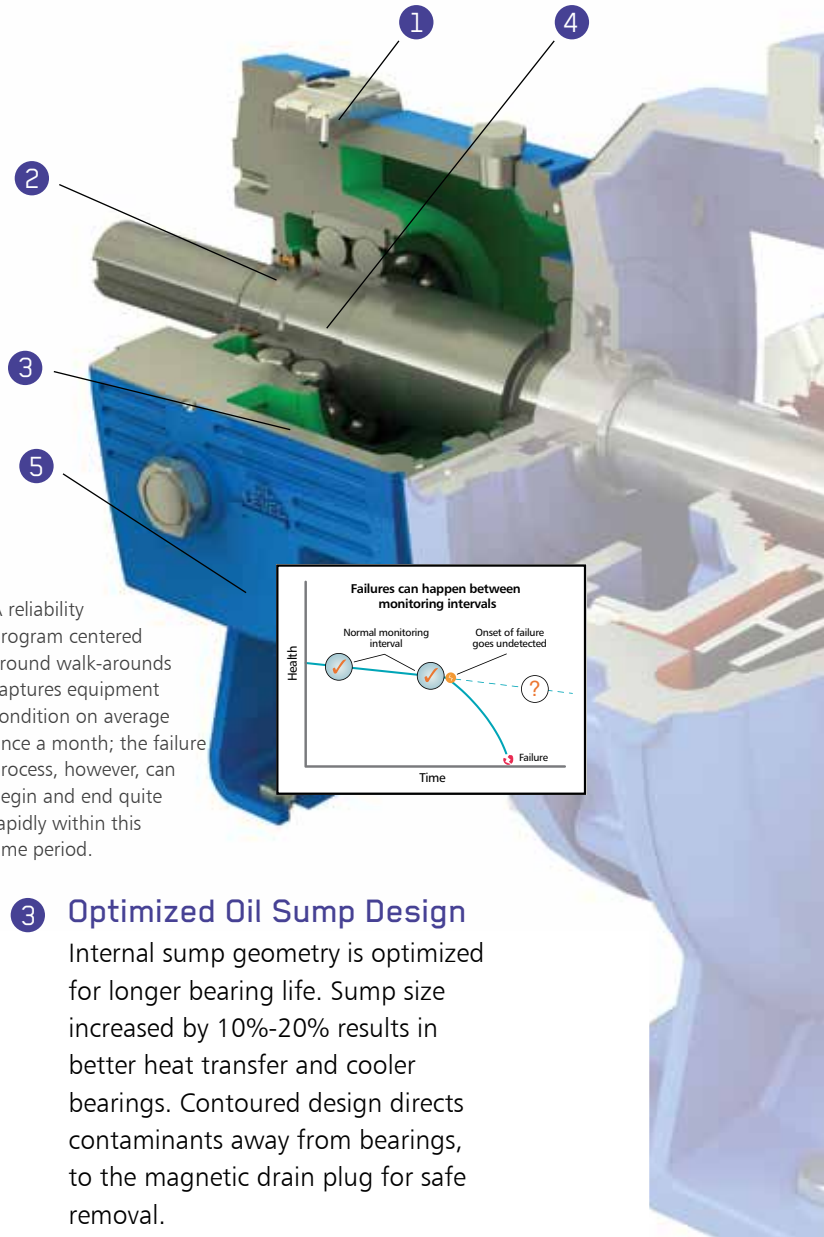
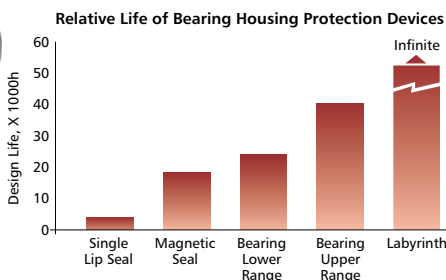

A reliability program centered around walk-arounds captures equipment condition on average once a month; the failure process, however, can begin and end quite rapidly within this time period.

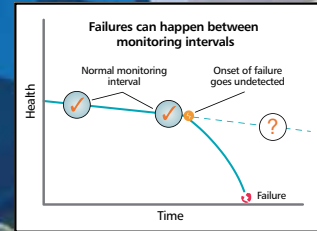

### 3 Optimized Oil Sump Design

Internal sump geometry is optimized for longer bearing life. Sump size increased by 10%-20% results in better heat transfer and cooler bearings. Contoured design directs contaminants away from bearings, to the magnetic drain plug for safe removal.

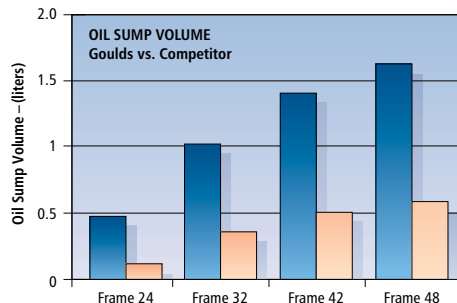

**Larger Means Cooler**  
■ GOULDS  
■ Industry Average

#### 4 Shaft and Bearings Engineered for Maximum Reliability

Every IC *i-FRAME* Power End is engineered and manufactured for optimal pump performance and increased MTBF.

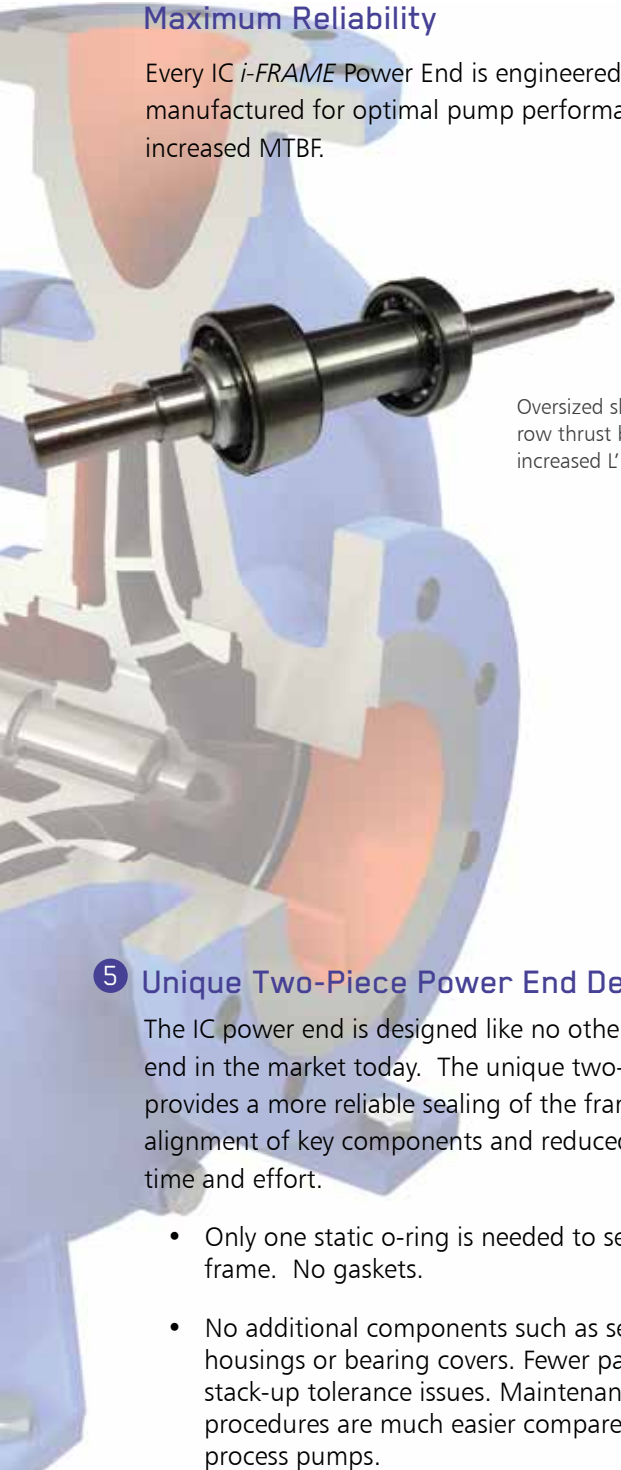

Oversized shaft with double row thrust bearings provide increased L<sub>10</sub> life by 40%.

#### 5 Unique Two-Piece Power End Design

The IC power end is designed like no other pump power end in the market today. The unique two-piece design provides a more reliable sealing of the frame, better alignment of key components and reduced maintenance time and effort.

- Only one static o-ring is needed to seal the entire frame. No gaskets.
- No additional components such as separate bearing housings or bearing covers. Fewer parts means less stack-up tolerance issues. Maintenance and repair procedures are much easier compared to other process pumps.
- One precision machined fit pilots the two power end halves together. More reliable and repeatable alignment between the bearings, shaft, seal, impeller and casing.
- No dynamic elastomeric seals! Only non-contacting labyrinth oils seals with static o-rings. No dynamic seal components that could wear out and leak. Provides more reliable lubrication retention and a cleaner environment for the high performance bearings.

ISO 5199 Shaft Specification	Meets	Exceeds
Diameter Tolerance		✓
Surface Finish		✓
Runout	✓	
Deflection		✓

The rugged shaft and bearing combination maintains shaft deflection of less than 50  $\mu\text{m}$  at all operating points. The result is longer seal and bearing life.

#### Premium severe-duty thrust bearings increase bearing life.

- High purity steels have fewer inclusions than standard steel – better grain structure and wear resistance.
- Heat treatment of bearing elements to 50 stabilization levels provides superior thermal stability for increased service life.
- Bearing Balls are manufactured to at least one ISO grade above standard (ISO P5 for ring running accuracy and ISO P6 for dimensions). The result is reduced vibration and noise for improved shaft guidance.

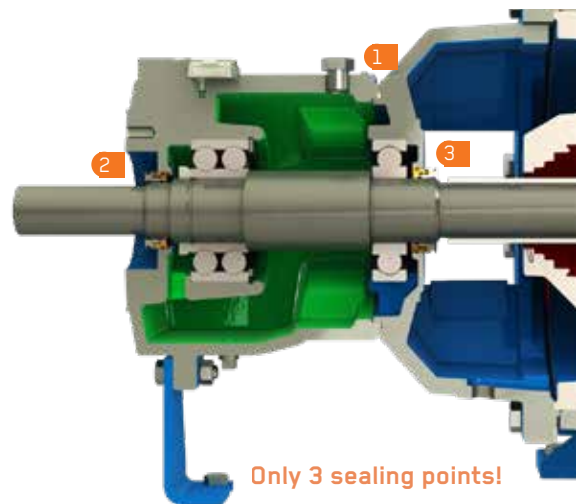

#### Our Guarantee

We are so confident that the *i-FRAME* is the most reliable Power End in the industry, that we are proud to offer a standard 5-year warranty on every ISO and ANSI *i-FRAME* Process Pump.



# Hydraulic Coverage

## 50Hz Performance

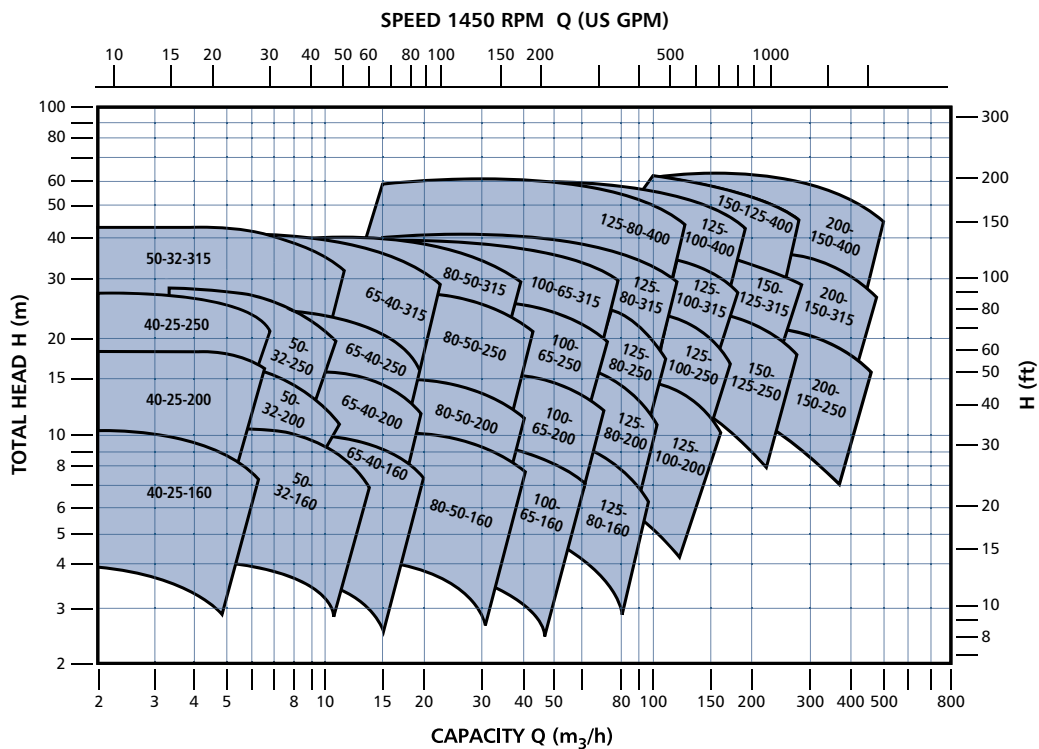
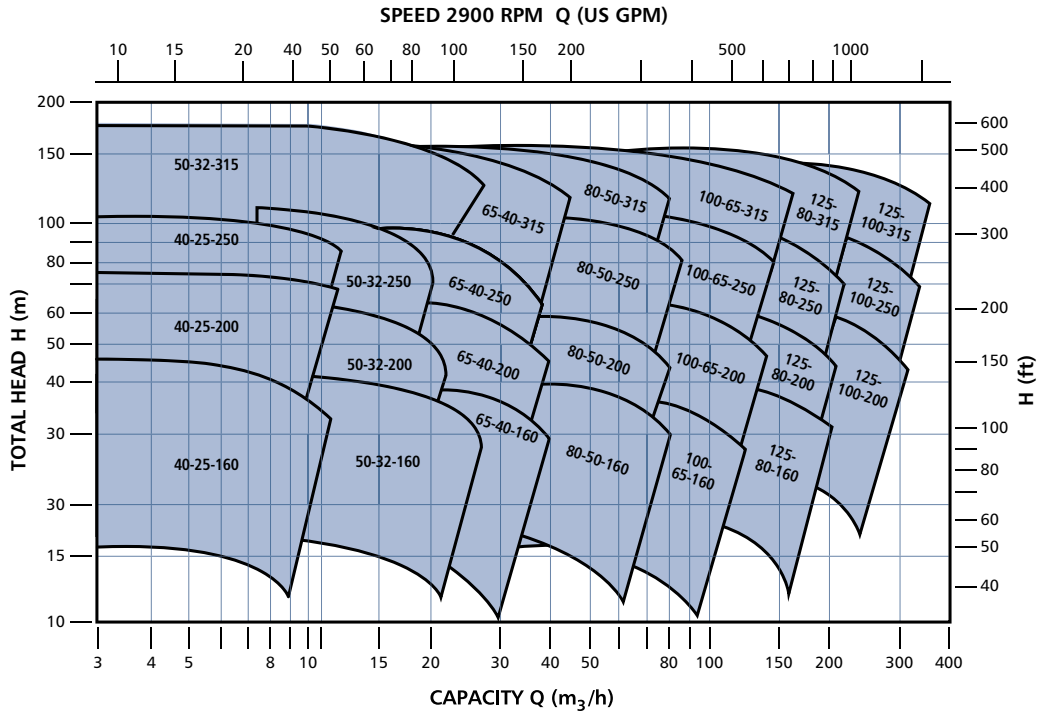



## 60Hz Performance

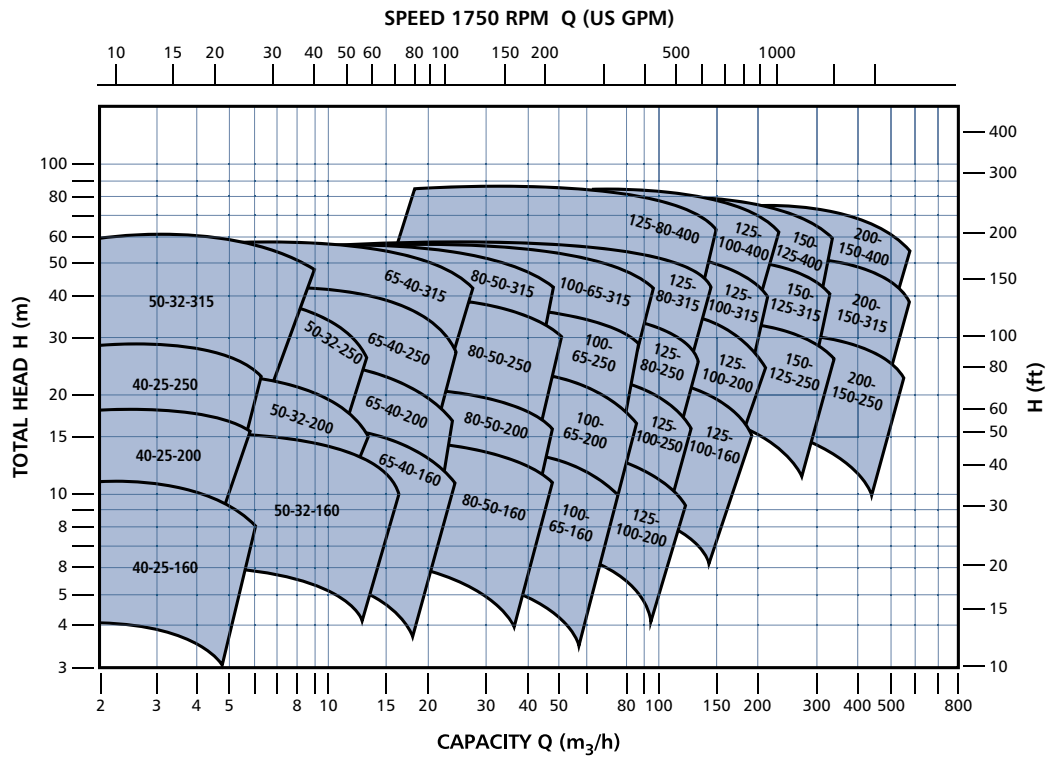
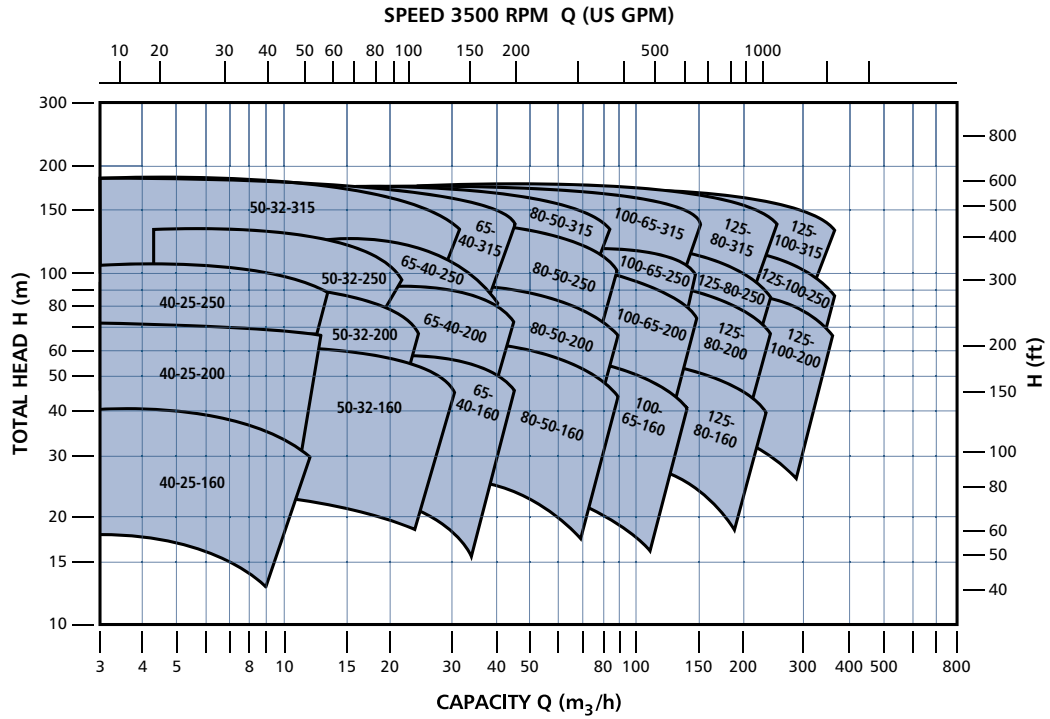

# Sealing Solutions



## Engineered to Extend Seal Life and Lower Maintenance Costs

Based on close to 170 years of providing pumping solutions to the Chemical Process Industry, ITT Goulds Pumps can provide a shaft sealing system that best meets your application requirements. Key to our shaft sealing program is placing the best shaft sealing solution in the best operating environment for long life and reduced maintenance and operating costs.

---

### Maximum seal flexibility

Because selecting the best seal for the application is key to extended pump reliability, seal chambers for the Model IC pump have been designed in accordance with ISO 3069 to support the use of a wide range of seals.

The shaft sealing arrangements possible include the use of any DIN 24960L 1K compliant seal arranged in single, single with quench, double (back-to-back) or tandem configurations.

### Patented Cyclone Seal Chamber Design

At the heart of our program is the patented cyclone seal chamber that not only provides the optimum seal environment in the presence of solids and vapors, but also improves maintainability and reduces installation cost by eliminating seal flush piping.

## IC Packing

Packing is likely the oldest method of shaft sealing. In general it is a very flexible sealing system. Today packing comes in a wide variety of choices. For some application its still very popular method of sealing pumps because of its low upfront cost, easy installation, and readily available materials.

Standard arrangement of packing is one ring of packing, a PTFE lantern ring and then three more rows of packing. A two piece 316SS stainless steel (1.4408) packing gland is then provided for adjustment of packing compression to achieve sealing and control of the leakage rate.

For the Model IC pumps two grades fo packing are offered:

- A. Standard PTFE Impregnated Fiber
- B. Optional Packing is PTFE impregnated Graphite

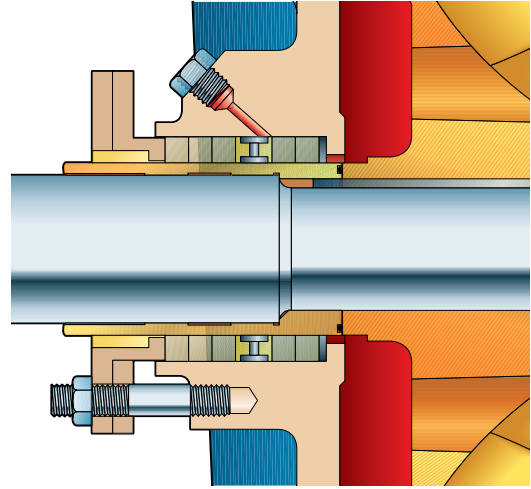

	Seal Chamber / Cover Arrangement			
		Cyclone Seal Chamber		
Shaft Seal System	Stuffing Box	Standard Version	With Quench Gland	For Cartridge Seal
Packing	A	C	C	C
DIN 24960 Single	B	A	C	C
DIN 24960 Single with Quench Cover	C	C	A	C
Single Cartridge Seal	C	C	C	A
Double Cartridge Seal (Tamdem and Back to Back Arrangement)	C	C	C	A

A = Recommended Sealing Environment

B = Suitable Environment, however not the best.

C = Does No Installations of this sealing system.

## Sealless Solutions

Not all process pump applications ISO can be sealed with optimum reliability. Goulds dimensional magnetic drive sealless process pumps are perfect solutions to mechanical seal or environmental sealing problems. The ICM metal magnetic drive process pump has a revolutionary bearing cartridge design for maximum reliability and ease of maintenance.

# Goulds Engineered Pump Mounting Systems

Proper installation and alignment are two key elements to maximize pump reliability. There are multiple mounting systems for the Model IC series. Simple to install, they provide a mounting platform resistant to corrosion and distortion while maintaining pump alignment and dampening the effect of harmful vibrations.

## Standard Baseplate Design

- Rigid fabricated steel design
- Machined pump and motor mounting surfaces make final alignments quick and accurate
- Dimensions conform to ISO 3661 for easy installation
- Suitable for grouted and ungrouted applications
- Optional drip pan with 1" drain connection
- Available in stilt mounted arrangement



## Feature Baseplate Design

- Structurally reinforced for maximum torsional and axial stiffness
- Machined pump and motor mounting surfaces
- Complies with ISO 3661
- Includes value-added features:
  - Stainless steel drip pan with 1" drain
  - Motor adjustment screws
  - Vertical leveling screws
  - Earthing lug



# Standard Options

## Designed for Flexibility to Meet Customer Needs

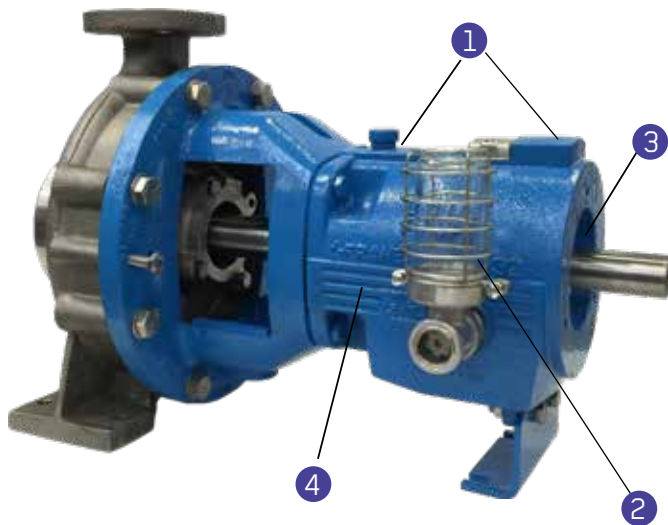

### Bearing Frame Options

- 1 GREASE LUBRICATION**  
Fitted with grease fitting for regreasable bearings or sealed for grease for life bearings.
- 2 CONSTANT LEVEL OILER**  
Preset for correct oil level. Oil reservoir decreases maintenance intervals.
- 3 MAGNETIC OIL SEAL**  
Optional Magnetic oil seals provide a sealed bearing housing for special applications. Requires addition of frame breather fitting.
- 4 PROVISIONS FOR BEARING MONITORS**  
Tapped connections for thermocouple and vibration sensing monitoring.

### Suction Inducer

All sizes of the Model IC ISO chemical pump can be supplied with an optional suction inducer which can extend the operating range of the pump by improving the inlet flow into the impeller, resulting in reductions of NPSHr. Inducers provide a more economical pumping solution as smaller, faster pumps can often be used. In addition, inducers can help eliminate cavitation caused by intermittent process conditions and entrained gas or vapor.

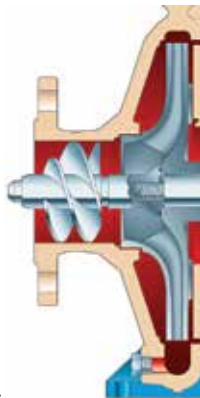

### Inducer benefits:

- Reduces NPSHr by 35–50% – ideal for marginal NPSH applications
- Allows for use of smaller, faster pumps – reducing costs
- Eliminates pumping problems on services with entrained gas
- No compromise to pump operating range
- All sizes available in stainless steel and higher constructions.
- Proven design with over 30 years of application experience.

### Bearing Frame Finned Cooler

Directly cools oil for lower bearing operating temperature. Requires minimal cooling water. Corrosion resistant construction. Recommended for temperatures over 180° C when using conventional oil.



### Case Wear Rings

Renews pump performance.

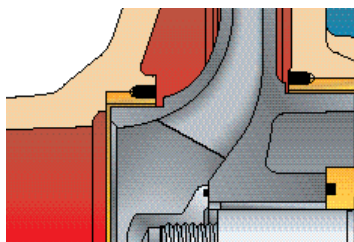

### Jacketed Casing and Seal Chamber

For heating and cooling of product.

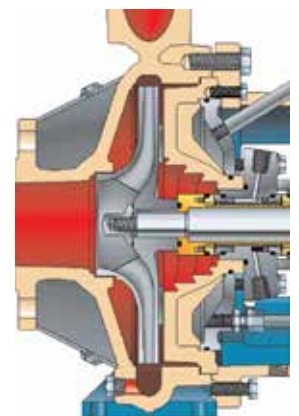

# Standard Options

Gould's Pumps offers a complete range of pump mounting systems to meet plant requirements; make installation and maintenance easier.

All API seal flush and cooling plans are available to control emission levels and meet seal installation requirements of user preference.

## API PLAN 31

- Product recirculation from discharge through a cyclone separator
- Lubricates single seal faces



## API PLAN 52

- Unpressurized buffer fluid circulation
- Lubricates double seal faces



# i-ALERT<sup>®</sup> Monitoring Solution

## Sensor | App | Ai Platform

www.i-alert.com



### What it Does:

#### Monitor

Tracks vibration, temperature & run-time hours 24/7/365.

#### Alarm

Takes high resolution data when an alarm condition occurs and stores it for later analysis.

#### Trend

Captures data every 1-60 minutes and has up to 170 days of hourly on-board storage.

#### Analyze

Diagnose machine faults with vibration tools  
Fast Fourier Transform (FFT) & Time Wave Form Analysis.

#### Environment

Rated for any industrial environment. water & dust resistant.  
Intrinsically Safe with a 3-year battery life (use dependent).  
• ATEX Zone 0 AEx ia IIB Ga (Groups C & D)

#### Wireless

Sync data via Bluetooth Smart enabled smartphones and tablets.

#### Online Monitoring

Monitor and manage all of your i-ALERT enabled machines in one place - i-ALERT Ai Online Platform. This subscription service requires no software to download or dedicated hardware to run.



Spend less time collecting data and more time fixing problems. The i-ALERT mobile app has the ability to scan multiple i-ALERT2 sensors within range to quickly and safely inspect multiple machines.

### How it Works:

#### 1. ACTIVATE

The i-ALERT2 devices are light activated by removing the sticker. The sensor begins wirelessly broadcasting once activated.

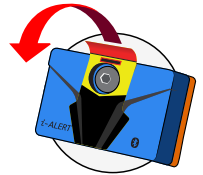

#### 2. AUTO CONFIGURATION

The i-ALERT device averages the vibration over 25 hours of run-time and sets the alarm levels to 2 x average (0.1-1.5ips minimum). Temperature alarm default to 80°C (176°F)

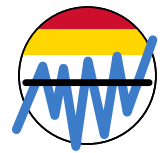

OR

#### 2. MANUAL CONFIGURATION

User manually sets the alarm thresholds via the i-ALERT mobile application.



#### 3. Monitor

The i-ALERT2 sensor is configurable to check every 1-5 minutes. If two consecutive readings are above alarm threshold the i-ALERT device will go into alarm.



#### Dashboard

Simple, intuitive dashboard to track vibration, temperature, run-time & battery life.



#### Trending

Trend vibration, temperature, & kurtosis to monitor any changes in the equipment operation.



#### BOM

Load the as built of materials based on the pump serial number.

# Dimensions

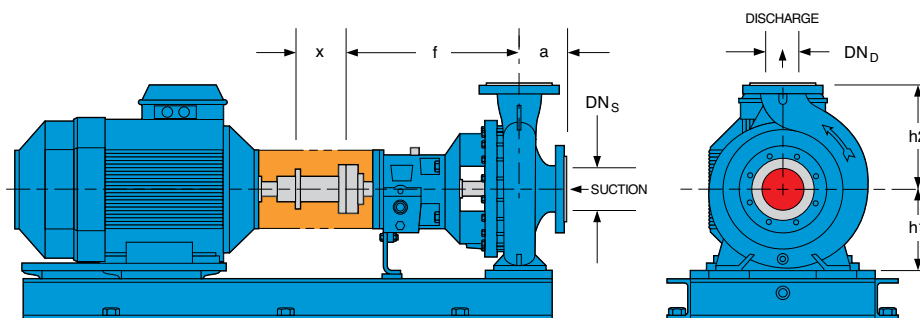

## DIMENSIONS

Pump size	Frame	Flanges		a	f	h1	h2	X	Bare pump weights
		Dns	DNd						
40-25-160	24	40	25	80	385	132	160	100	42
40-25-200	24	40	25	80	385	160	180	100	50
40-25-250	32	40	25	100	500	180	225	100	79
50-32-160	24	50	32	80	385	132	160	100	43
50-32-200	24	50	32	80	385	160	180	100	53
50-32-250	32	50	32	100	500	180	225	100	83
50-32-315	32	50(1)	32(1)	125	500	200	250	100	111
65-40-160	24	65	40	80	385	132	160	100	44
65-40-200	24	65	40	100	385	160	180	100	54
65-40-250	32	65	40	100	500	180	225	100	85
65-40-315	32	65(1)	40(1)	125	500	200	250	100	121
80-50-160	24	80	50	100	385	160	180	100	50
80-50-200	24	80	50	100	385	160	200	100	57
80-50-250	32	80	50	125	500	180	225	100	88
80-50-315	32	80(1)	50(1)	125	500	225	280	100	126
100-65-160	32	100	65	100	500	160	200	100	74
100-65-200	32	100	65	100	500	180	225	140	79
100-65-250	32	100	65	125	500	200	250	140	98
100-65-315	42	100(1)	65(1)	125	530	225	280	140	155
125-80-160	32	125	80	125	500	180	225	140	81
125-80-200	32	125	80	125	500	180	250	140	87
125-80-250	32	125	80	125	500	225	280	140	109
125-80-315	42	125(1)	80(1)	125	530	250	315	140	165
125-80-400	42	125	80	125	530	280	355	140	210
125-100-200	32	125	100	125	530	200	280	140	93
125-100-250	42	125	100	140	530	225	280	140	134
125-100-315	42	125(1)	100(1)	140	530	250	315	140	180
125-100-400	42	125	100	140	530	280	355	140	218
150-125-250	42	150	125	140	530	250	355	140	151
150-125-315	42	150	125	140	530	280	355	140	180
150-125-400	42	150	125	140	530	315	400	140	252
200-150-250	42	200	150	160	530	280	375	180	195
200-150-315	48	200	150	160	670	315	400	180	257
200-150-400	48	200	150	160	670	315	450	180	305

## Cast Material Standards

	Standards	
	DIN	ASTM
Cast Iron	0.6025	A48, Class 35
	0.7043	A3695, Grade 60-40-18
Carbon Steel	1.0619	A216 WCB
Stainless Steel	1.4408	A744 CF-8M
	1.4404	A744 CF-3M
Duplex SS	1.4517	Duplex SS - A995 CD4-McuN
Super Duplex	1.4469	A995 CD3MWCuN
Alloy 20	1.4527	A744 CN-7M
Hastelloy C	2.4686	A 494 CW-2M
Hastelloy B	2.481	A 494N-1 2MV
Titanium	3.7031	B367 Grade 2

Dimension in mm

Dimensions subjected to change without notice

Note: Flange drilling in accordance with ISO 7005 PN 16 except where noted

(1)-Flanges drilled PN25

Detailed pump dimensions in accordance with ISO 2858/EN22858

Detailed baseplate dimensions in accordance with ISO 3661/EN23661



# Parts List & Materials of Construction

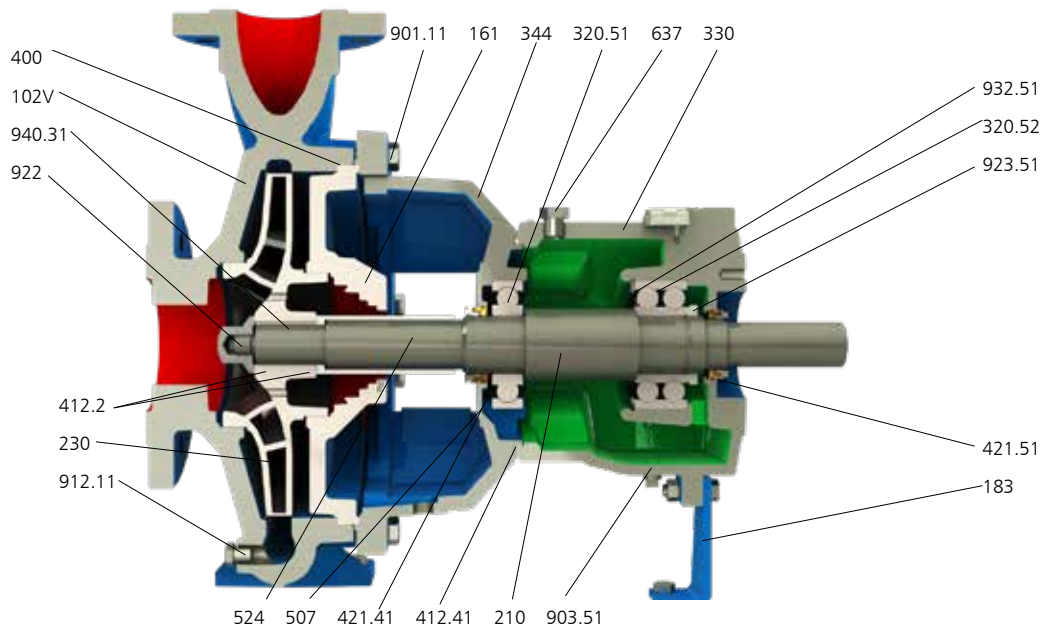

Material										
Item Number	Part Name	Ductile Iron	Carbon Steel	316ss	Duplex	Alloy 20	Hastelloy	Titanium	Nickel	Inconel
102V	Casing	Ductile Iron	CS	316ss	Duplex	Alloy 20	Hastelloy	Titanium	Nickel	Inconel
161	Seal Chamber	Ductile Iron	CS	316ss	Duplex	Alloy 20	Hastelloy	Titanium	Nickel	Inconel
	Stuffing Box Cover									
183	Support Foot	Carbon Steel								
210	Shaft	Stainless Steel								
230	Impeller	316ss	316ss	316ss	Duplex	Alloy 20	Hastelloy	Titanium	Nickel	Inconel
320.51	Radial Bearing	Single Row, Ball Bearing								
320.52	Thrust Bearing	Double Row Angular Contact Ball Bearing								
330	Bearing Bracket	Cast Iron								
344	Lantern	Ductile Iron								
400	Case Gasket	Non Asbestos Aramid Fiber								
412.21	O-ring, Shaft Sleeve & Impeller Nut	PTFE								
412.41	O-ring, Bearing Bracket	NBR								
421.41	Oil Seal, Inboard	Bi-Metallic Labyrinth Seal (Steel & Bronze)								
421.51	Oil Seal, Outboard	Bi-Metallic Labyrinth Seal (Steel & Bronze)								
524	Shaft Sleeve	316LSS			Duplex	Alloy 20	Hastelloy	Titanium	Nickel	Inconel
637	Oil Vent / Filler Plug	Steel								
642	Oil Level Sight Glass	Glass/Plastic								
901.11	Casing Bolts, Hex Cap Screw	Stainless Steel								
901.12	Support Foot Bolt	Carbon Steel								
	Hex Cap Screw									
901.31	Lantern-Cover, Hex Cap Screw	Stainless Steel								
901.41	Brg Bracket-to-Lantern Bolts	Carbon Steel								
	Hex Cap Screw									
901.42	Jacket Bolt	Stainless Steel								
903.51	Drain Plug	Carbon Steel								
912.11	Case Drain Plug					Alloy 20	Hastelloy	Titanium	Nickel	Inconel
922	Impeller Nut	Duplex			Alloy 20	Hastelloy	Titanium	Nickel	Inconel	
923.51	Bearing Lock Nut	Steel/Nylon								
932.51	Snap Ring	Carbon Steel								
940.31	Impeller Key	Carbon Steel								

Other Parts Not Shown										
230	Inducer (optional)	Duplex			Alloy 20	Hastelloy	Titanium	Nickel	Inconel	
452	Packing Gland	316SS								
458	Lantern Ring	Glass Filled PTFE								
461	Packing	PTFE Impregnated								
502.11	Wear Ring (Optional)	316SS			Duplex	Alloy 20	Hastelloy	Titanium	Nickel	Inconel

Other Alloys available: 316L, 317, 317L, Super Duplex etc...

# Modular Interchangeability

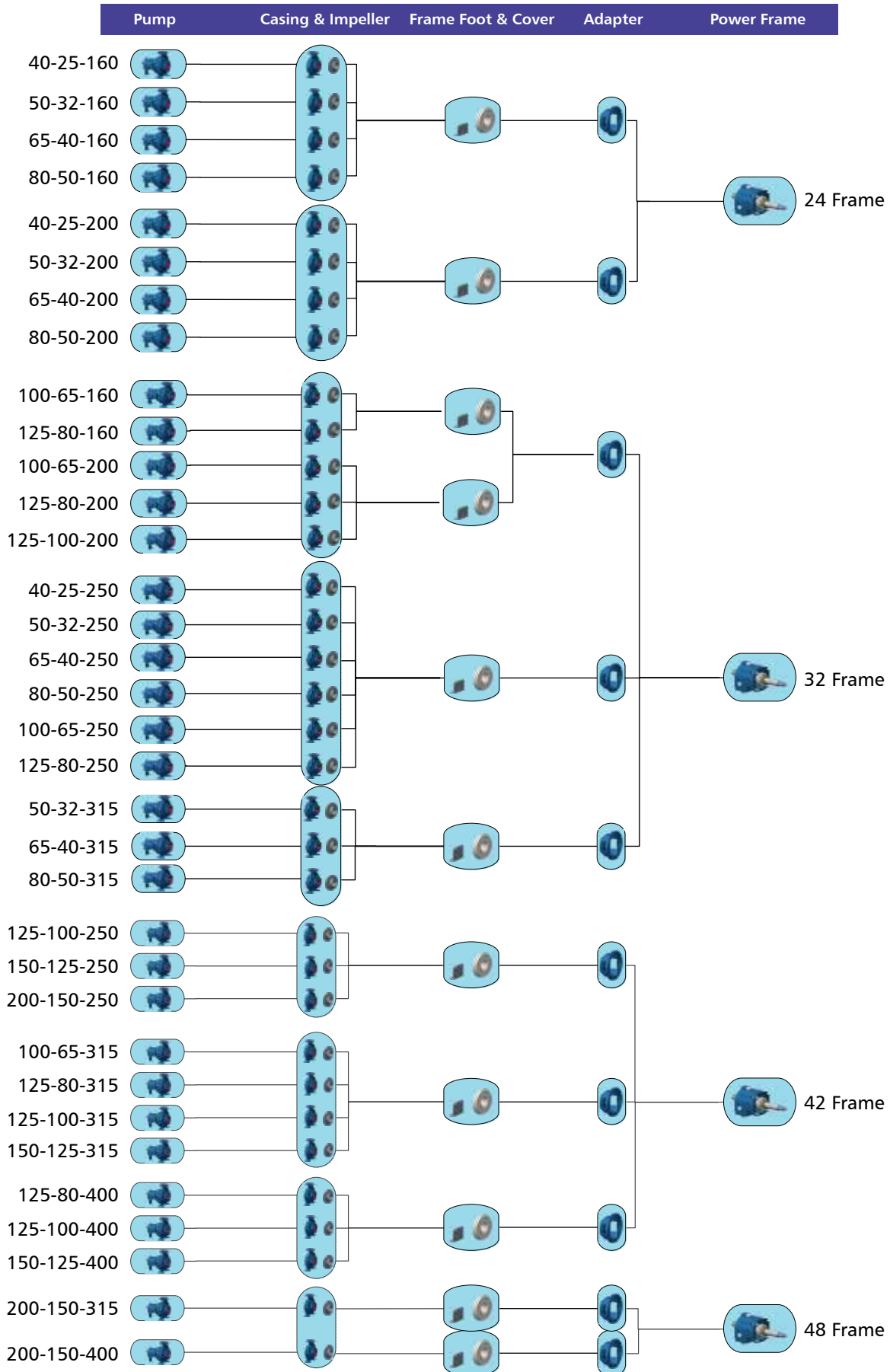

# Construction Details

		24	32	42	48
Shaft	Diameter at Impeller	19	28	38	48
	Diameter in stuffing box/Seal Chamber	33	43	53	65
	Diameter between Bearings	44	54	68	78
	Diameter at Coupling	24	32	42	48
	Maximum shaft Deflection	0.05			
Bearings	Radial	6307 C3	6309 C3	6311 C3	6313 C3
	Thrust	3307A C3	3309A C3	3311A C3	3313A C3
	Bearing span	105	170	143	246
Power Limit	KW per 100 RPM	0.75	2.2	4.4	9.8
Temperature	Maximum Liquid Temperature Oil/Grease Lubrication without Cooling	160°C			
	Maximum Liquid Temperature Oil/Grease Lubrication with High Temp. Option	180°C			
Casing	Corrosion Allowance	3 mm			

# IC Series

## Goulds ICP Series

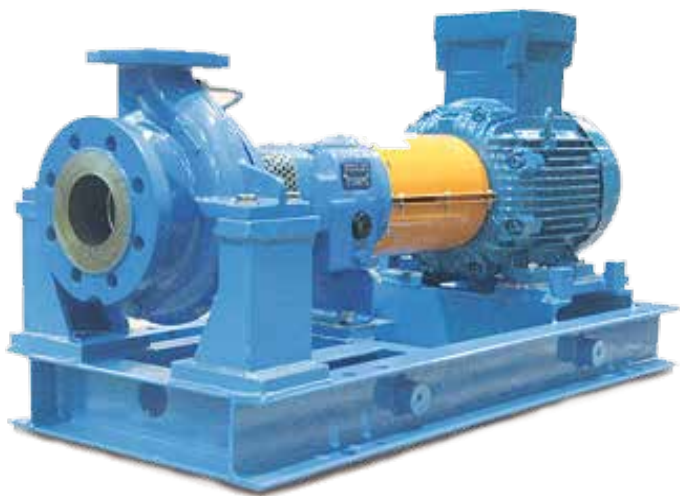

### High Pressure and High Temperature

The ICP is a heavy duty chemical process pump designed for extreme temperatures (-40° C to 280° C) and pressures to 25 Bar. Centerline mounted casing controls thermal growth and maintains pump alignment for extended seal life. Complies with ISO 5199.

### Specifications

- Capacities to 450 m<sup>3</sup>/h (1980 USgpm)
- Heads to 150 m (492 feet)
- Temperature Range -40°C to 280°C (-40° F to 535° F)
- Pressures to 25 Bar (363 PSIG)
- Materials – Carbon Steel, Stainless Steel, Duplex Stainless Steel, Hastelloy C

---

## Goulds ICB Series



### Close-coupled, Economical Installation

The ICB close-coupled chemical process pump provides an economical, space-saving design, which simplifies installation and reduces costs. Precise alignment eliminates the multiple craft installation costs.

No baseplate. No flexible coupling. Floor space utilisation is maximized. Complies with ISO 2858. Available on all frame 24, 32, and 42 pump sizes.

### Specifications

- Capacities to 340 m<sup>3</sup>/h (1490 USgpm)
- Heads to 160 m (525 feet)
- Temperature Range -40° C to 140°C (-40° F to 280° F)
- Pressures to 16 Bar (235 PSIG)
- Materials – Ductile Iron, Stainless Steel, Duplex Stainless Steel

# Leadership in Sealless Pump Technology

## Design Features for Extended Pump Life

### Bearing Cartridge

Individual bearings are contained in a single cartridge assembly.

- Bearings are made of highly abrasion and corrosion resistant silicon carbide. Dryguard™ bearings are available for protection against occasional dry run conditions.
- In the event of bearing failure, the cartridge design contains the bearings and prevents further damage to pump internals.
- Installation and replacement of bearings is simple. Only one component to install.



### Containment Shell

The containment shell is the most important component isolating the pumpage from the atmosphere.

- The containment shell is a deep-drawn single piece design made from Hastelloy C for reliable corrosion resistance.
- The vortex-breaking bead at the bottom of the can prevents erosion.
- Burst pressure is greater than 150 bar.



### Dryguard™ Bearings

The heat generation from dry run conditions is the number one mode of failure for sealless pumps. Dryguard™ is a diamond-like carbon that reduces the coefficient of friction by over 70% enabling short periods of safe operation under dry run conditions.



Dryguard™ is up to 2X harder than silicon carbide, ensuring its benefits cannot be compromised in even the harshest conditions.

### High Temperature Applications

The High Temperature option is perfect for applications between 180°C and 280°C. This option includes Samarium Cobalt magnets and a special High Temperature bearing cartridge designed to handle the additional rate of thermal expansion.



## Goulds ICM-B Series

Close-Coupled Economical Design  
Specifications

- Block Pump design available on all Frame 24 sizes
- Adapters available for IEC Motor Frames
- Eliminates coupling and alignment concerns



# ICM Series

## Magnetic Drive, Sealless, Leak Proof

The ICM metallic magnetic drive process pump safely and reliably handles difficult fluids such as corrosives, toxic, and ultra pure liquids. Complies with ISO 2858, 5199, and 15783.

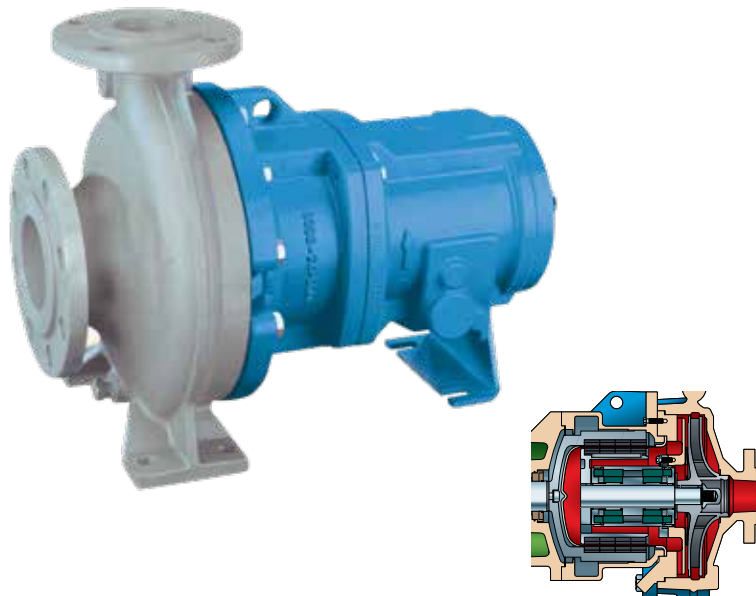

### Specifications

- Capacities to 340 m<sup>3</sup>/h (1490 US gpm) at 2900 rpm
- Heads to 160 m (525 feet) at 2900 rpm
- Temperature Range -40° C to 180° C (-40° F to 360° F), optional as ICMP up to 280° C (530° F)
- Pressures to 16 Bar (235 PSIG), optional 25 Bar (360 psi)
- Materials – Stainless Steel, Duplex Stainless Steel, Alloy 20, Hastelloy C

## Reliable, Simple – Easy To Maintain



### Maintenance Made Simple

The ICM was designed with the end user in mind. Fewer parts make planned maintenance faster and easier than other sealless and sealed process pumps. The S group is also available in a close coupled configuration, eliminating the need for time-consuming pump and motor alignment.

# Installations



# Locations



For more information Please Visit:  
[www.gouldspumps.com](http://www.gouldspumps.com) | [www.ittproservices.com](http://www.ittproservices.com)



— An ITT Brand

240 Fall Street  
Seneca Falls, NY 13148  
Phone: 315.568.2811  
Fax: 315.568.2418  
[www.gouldspumps.com](http://www.gouldspumps.com)

© 2022 ITT Goulds Pumps Inc.

B.ICIFRAME.en-US.2022-01