

# Goulds 3410

Small Capacity Double Suction Pump



# 3410

Double Suction Pumps Designed for a Wide Range of Industrial, Municipal, and Marine Services.

- Capacities to 8,000 GPM (1817 m<sup>3</sup>/h)
- Heads to 570 feet (174 m)
- Temperatures to 350° F (177° C)
- Pressures to 250 PSIG (1724 kPa)

## Design Features

- **Double Suction / Dual Volute** - Design assures axial and radial balance for long life, low maintenance.
- **Horizontally Split Casing** - Suction and discharge nozzles in lower half casing for ease of inspection/maintenance.
- **Wear Rings** - Easily replaceable wear rings protect against impeller, casing wear.
- **Sealing Flexibility** - Choice of a wide range of mechanical seal or packing.
- **Maximum Parts Interchangeability** - Entire line uses just five rotating assemblies (exclusive of impellers and wear rings).

## Services

- **Process** - Quench water, stripper bottoms, reboiler circulation, cooling tower
- **Pulp & Paper** - Primary and secondary cleaner, filtrate, mill water supply shower, fan pump
- **Primary Metals**- Cooling water, quench and leaching
- **Municipal** - High lift, low lift, wash water, waste water, raw water, booster, filter backwash
- **Utilities** - Cooling tower, component cooling, service water
- **Marine** - Bilge and ballast, cargo, cooling water, fire pump

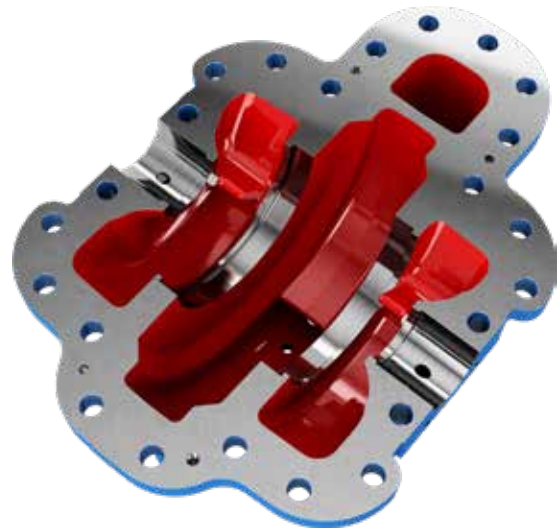

# Bearing Housing Features

## Grease Lubrication (Standard)

### EASY SERVICEABILITY

Grease lube pumps feature updated grease zerk location with unobstructed access.

### i-FRAME

Next generation bearing housing with integrated i-ALERT mounting capability for all of your remote condition monitoring needs

### GREASE PRESSURE RELIEF

Grease pressure relief ensures optimal grease amount without needing to remove drain plug.

### SHAFT GUARDS

Protection from rotating parts and easily accommodates common seal gland port and piping configurations.



## Oil Lubrication (Optional)

Field convertible with no remachining required.

### INCREASED BEARING LIFE

Additional cooling fins and 30% increased oil sump capacity for optimal bearing cooling.

### EASY VISIBILITY

Oil sight glass standard for easy indication of proper oil level. Also available with optional oiler not shown.

### IMPROVED SERVICEABILITY

Drain plug location allows for easy access even with the coupling guard installed.



# Hydraulic Coverage

60 Hz

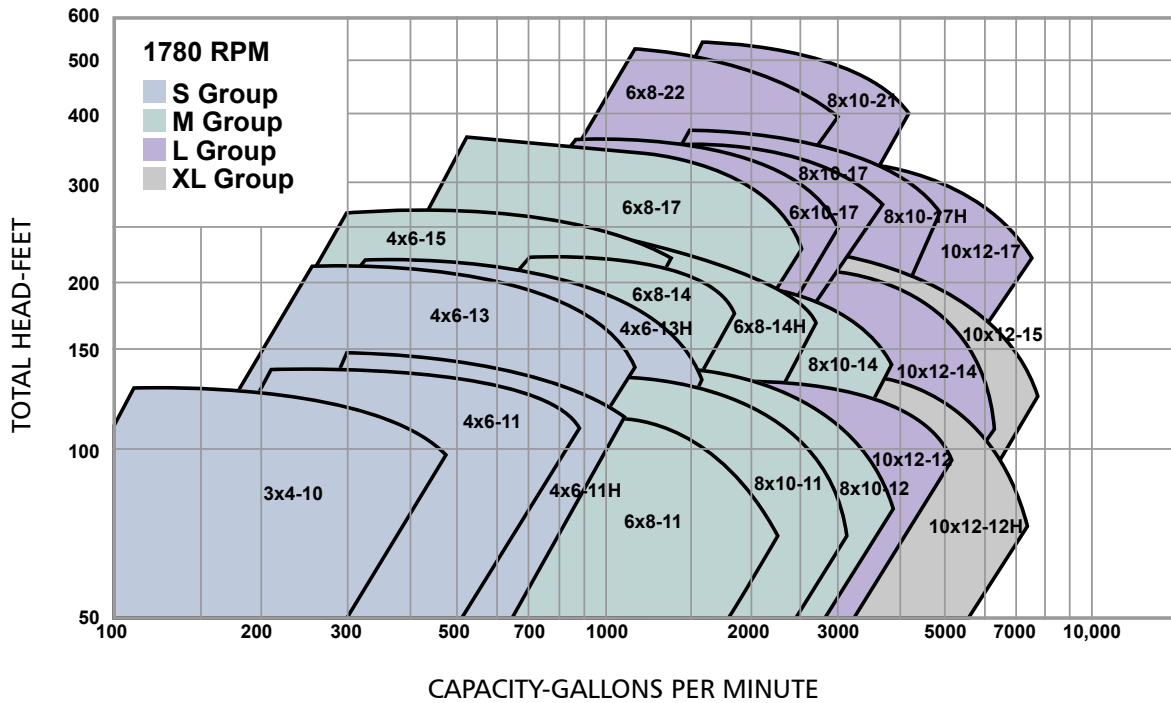
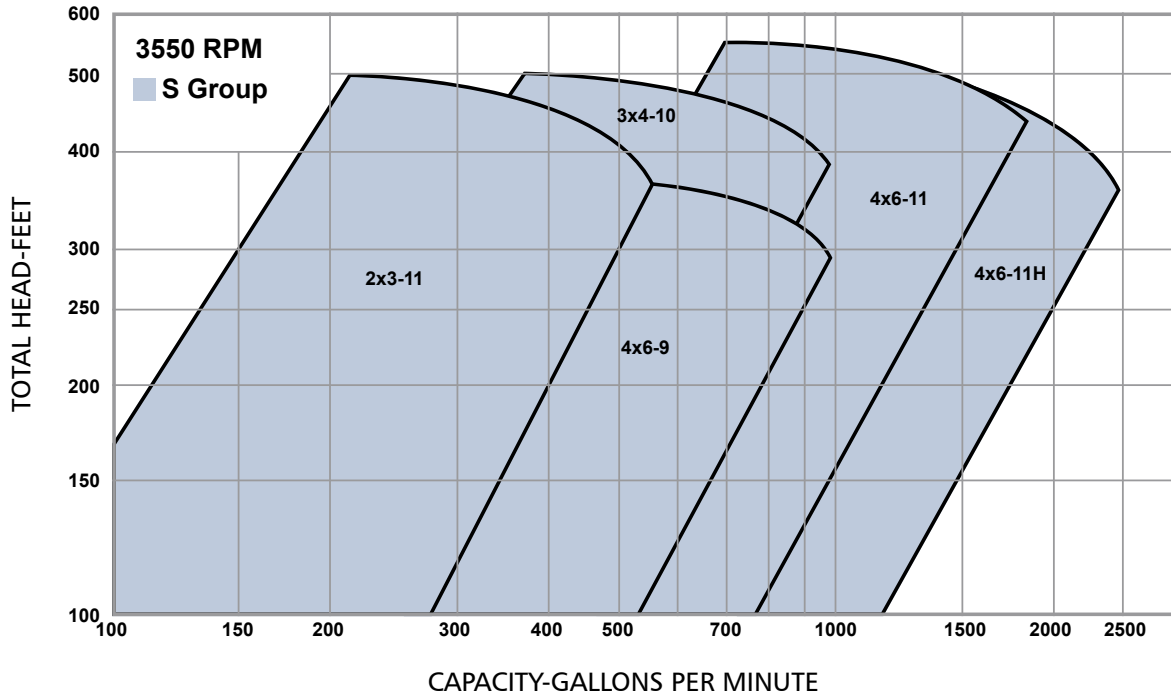

# 50 Hz

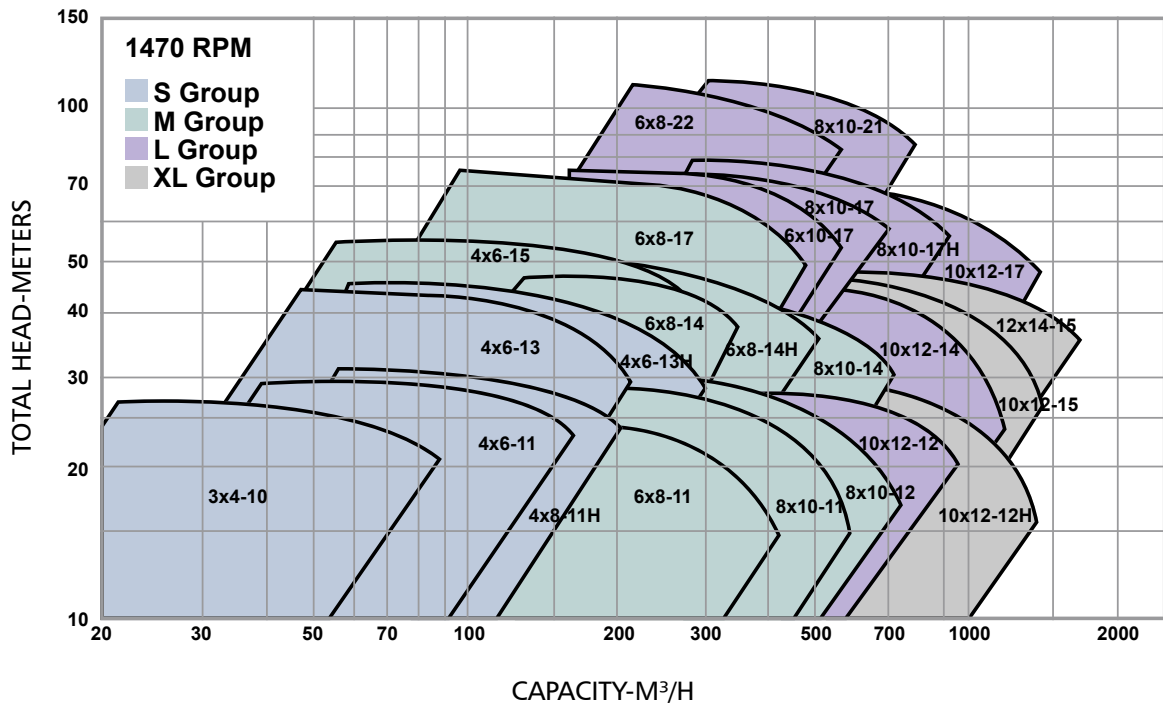
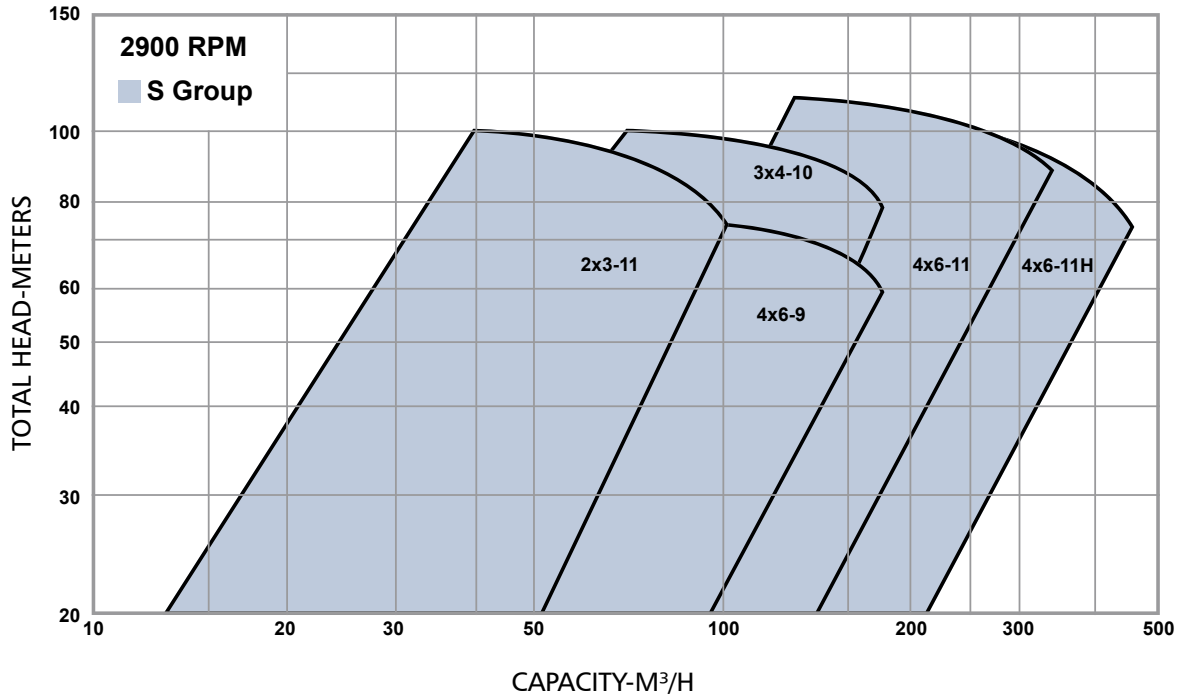



# 3410

## Parts List and Materials of Construction

Item Number	Qty/ Pump	Part Name	MATERIALS	
			Cast Iron/316SS	316SS
100	1 Upper 1 Lower	Casing	Cast Iron	316 SS
101	1	Impeller	316 SS	
102	2	Flush Line (Optional) (Not Illustrated)	PTFE Lined 304SS Hose	
103	2	Casing Wear Ring	Nitronic 60	
105	2	Lantern Ring (Optional) (Not Illustrated)	Glass Filled PTFE	
106	1 Set	Stuffing Box Packing (Optional) (Not Illustrated)	Square non-asbestos	
107	2	Stuffing Box Gland (Optional) (Not Illustrated)	316 SS	
109	2	Bearing End Cover	Cast Iron	
109A	1	Thrust Bearing End Cover	Steel	
112	1	Ball Bearing, Outboard	Steel	
113	2	Grease Fitting	Steel	
113A	2	Breather (Optional oil lubrication only) (Not Illustrated)	Steel	
122	1	Shaft	AISI 4140	
124	1	Sleeve Nut (M/L/XL only)	Nitronic 60	
125	2	Stuffing Box Bushing	316 SS	
126	2	Shaft Sleeve (Optional on S Grp)	316 SS	
134	2	Bearing Housing	Cast Iron	
142	2	Impeller Wear Ring (Not Illustrated)	316 SS	
168	1	Ball Bearing, Inboard	Steel	
178	1	Impeller Key	303 SS	
250	2	Mechanical Seal Gland (Flush STD)	Cast Iron	316 SS
251	2	Sight Oiler (Optional Oil Lubrication) (Not Illustrated)	White Metal & Glass	
320	6	Retaining Set Screws (For Optional Impeller Wear Ring) (Not Illustrated)	303 SS	
332A	1	Labyrinth Seal Outboard	Bronze/PTFE	
333A	2	Labyrinth Seal Inboard	Bronze/PTFE	
351	1	Parting Casing Gasket (Not Illustrated)	1/32 in. Non-Asbestos	
353	4	Gland Studs (Not Illustrated)	316 SS	
355	4	Gland Stud Hex Nut (Not Illustrated)	304 SS	
360	2	Gasket, End Cover to Bearing Housing	Kraft Paper	
361	1	Thrust Bearing Retaining Ring	Steel	
371C	8	Hex Cap Screw	Steel	
372U	4	Hex Cap Screw	Steel	
383	1	Mechanical Seal	As Required by Application	
428	2	Gasket, Sleeve to Impeller (M/L/XL Only)	1/32 in. Non-Asbestos	
443T	1	Bearing Space (L & XL Only)	Steel	
445A	2	Anti-Rotation Pin, Casing Wear Ring (Not Illustrated)	AISI 420	AISI 316
497	2	Sleeve Nut O-Ring (M/L/XL Only)	Buna Rubber	

Other materials available upon request.

### NSF Certified Construction

Complete range of NSF certified pumps available in 316SS fitted, all 316SS and nickel aluminum bronze fitted constructions for use in potable water applications.



# Sectional View

## S Group

Model 3410 S Group is standard less shaft sleeves. Sleeves to protect stuffing box area are optional. Impeller is key driven and held axially by retaining rings.

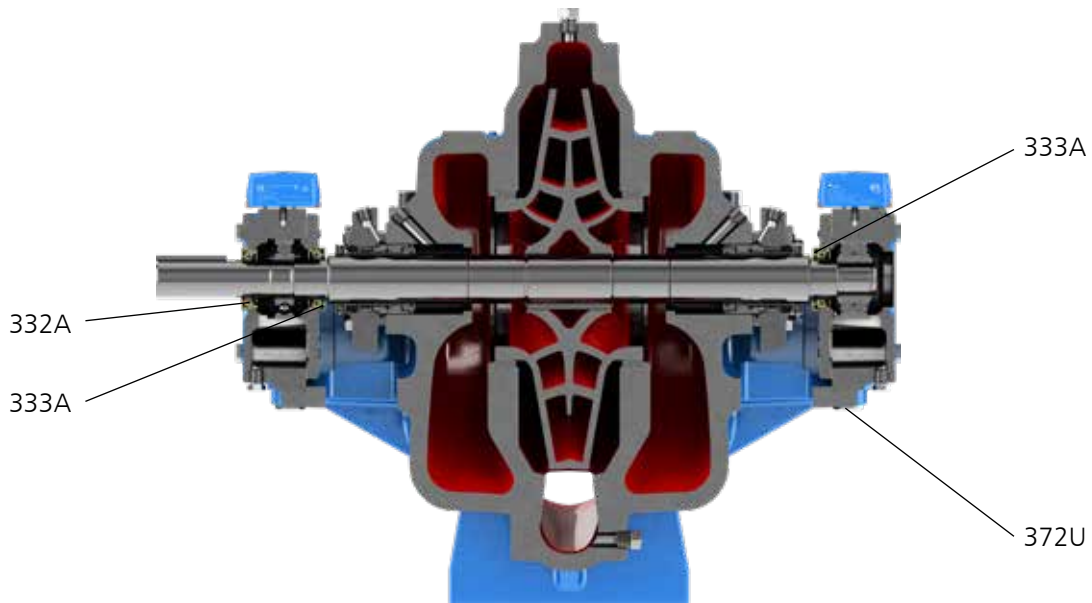

## M, L, XL Group

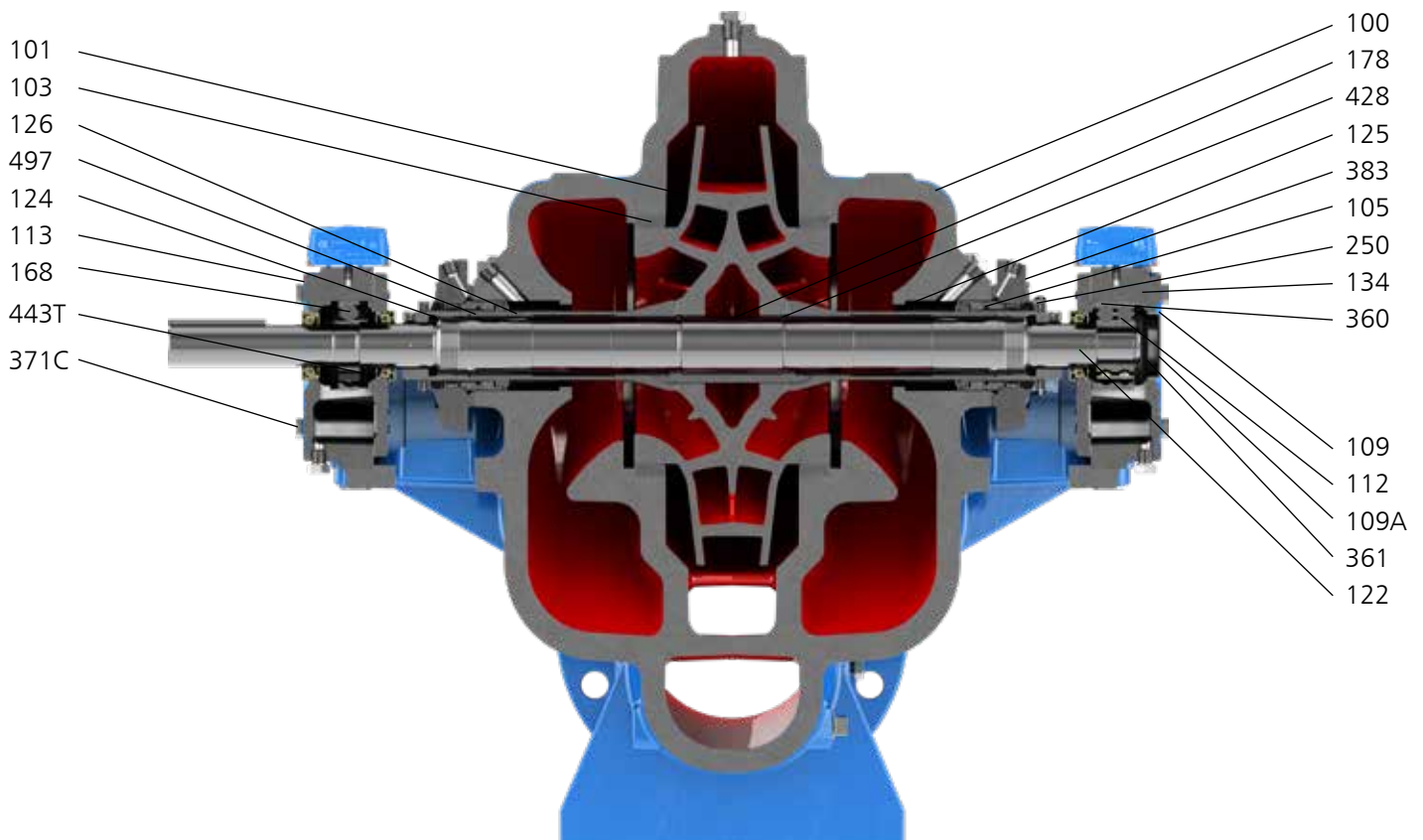

# 3410 Single Stage Double Suction Pumps

## Standard Design Features for Wide Range of Heavy Duty Industrial, Municipal & Process Services

### RENEWABLE CASE WEARING RINGS

Permits easy maintenance of proper running clearances. Locked in place by anti-rotation pins.

### DOUBLE SUCTION IMPELLER

Standard 316SS impeller provides excellent corrosion resistance and minimizes axial thrust for increased longevity. Polished waterways and fully machined exterior surfaces assure highly efficient, smooth performance.

### HEAVY DUTY SHAFT

Designed for minimum deflection at maximum load.

### STUFFING BOX

Enlarged stuffing box bores for improved seal lubrication and cooling result in extended seal life.

### CASING ACCESS PORT

Casing access port provides easy access to mechanical seal or packing gland bolts for improved serviceability.

### BALANCED DESIGN

Dual volute casing design equalizes radial forces and lessens radial reaction of shaft and bearings — assures smooth, vibration-free performance. Ideal when pumps must periodically operate at capacities above or below design capacity or during intermittent high head conditions. Combined with double suction impeller for axial balance, the 3410 is designed for long life, low maintenance. (Dual volute casing not available on all sizes.)

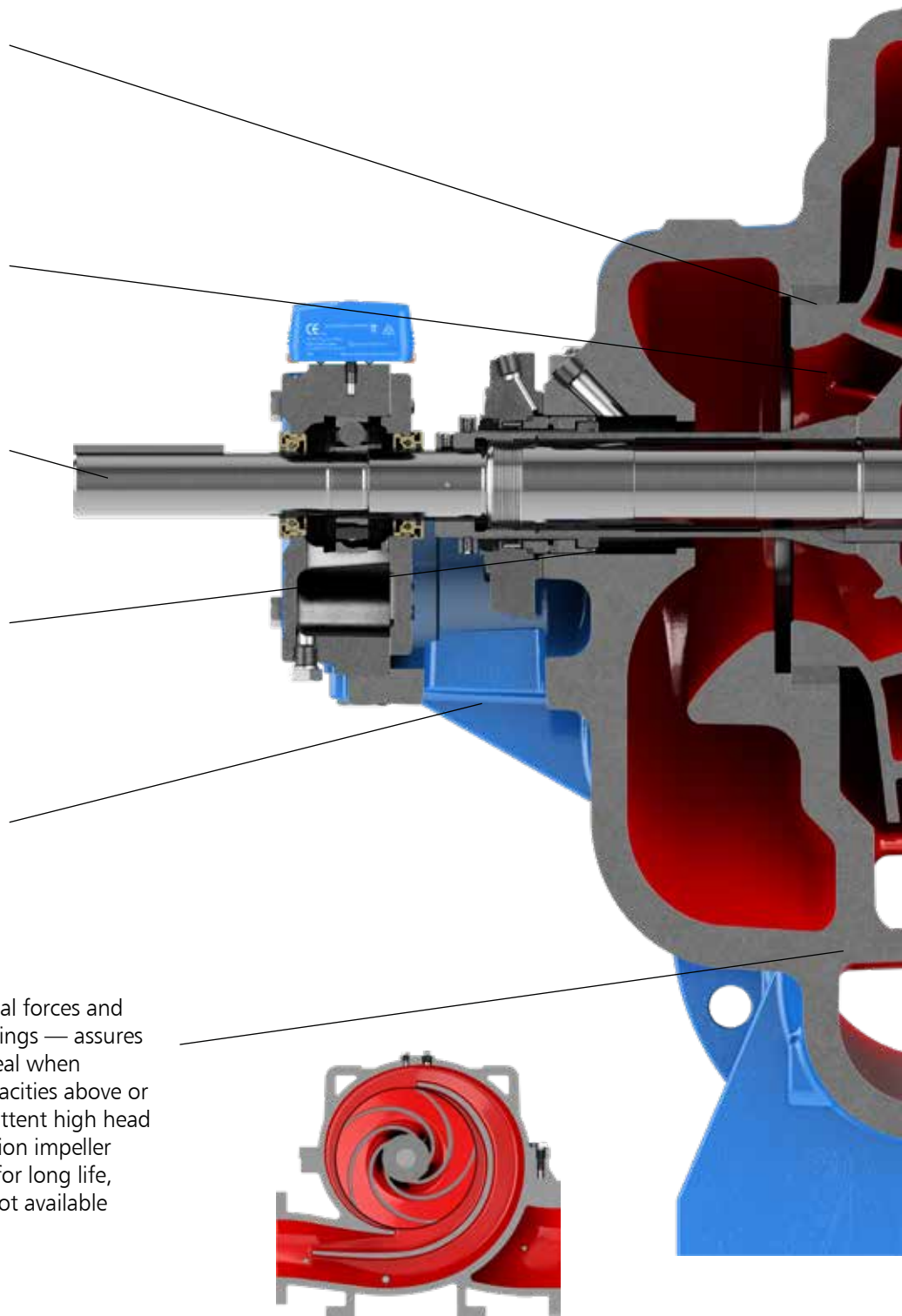

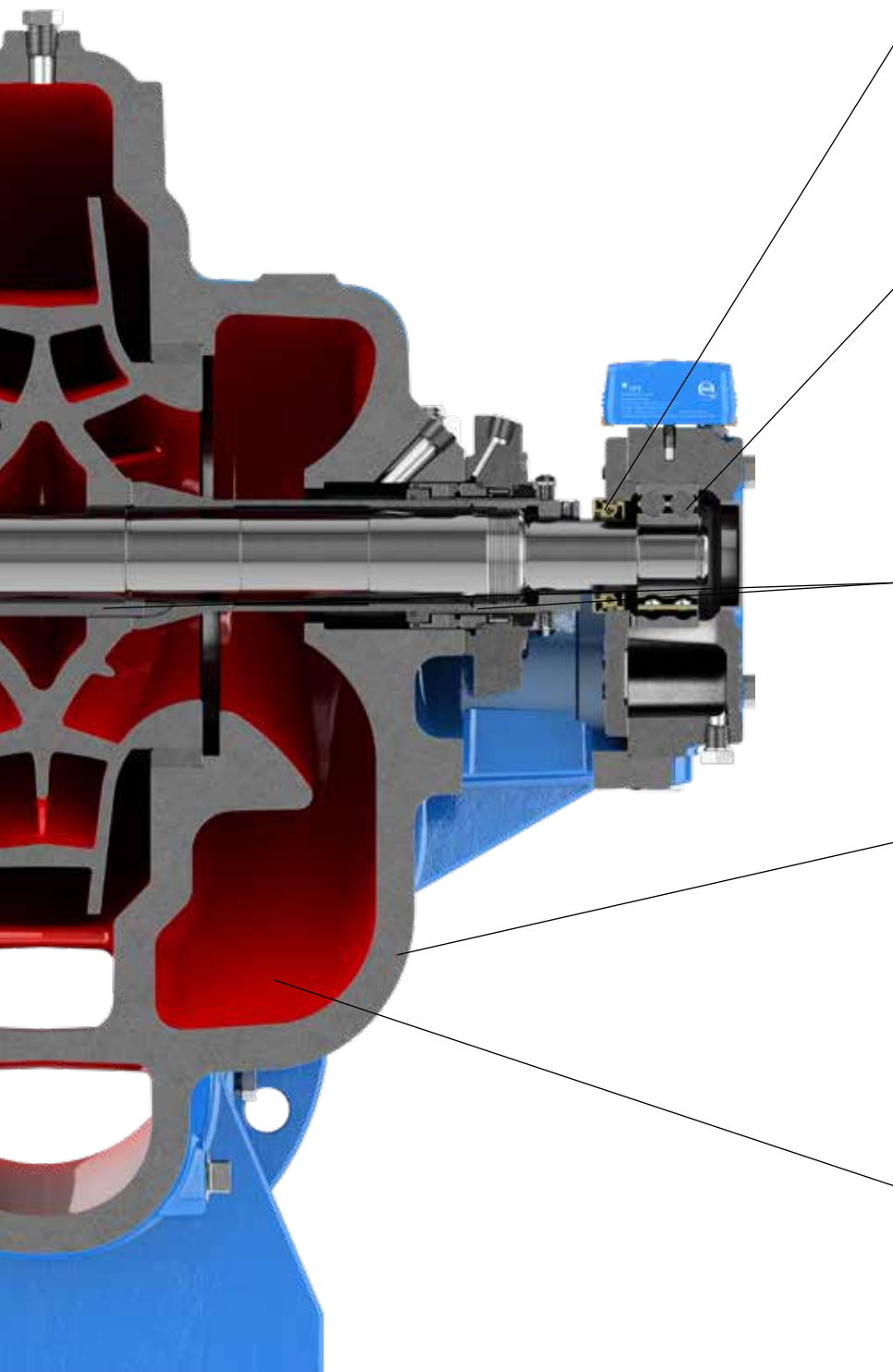

**LABYRINTH BEARING PROTECTION**

Labyrinth isolators are standard on the Model 3410. Ideal for eliminating contaminants and providing long life with no shaft wear or heat generation.

**DOUBLE ROW THRUST BEARING**

Regreasable double row thrust bearing for high axial thrust capability. Locked on shaft in bearing housing positively positions rotating element and carries any residual axial thrust. Oil lubrication and constant level oiler with viewport are optional.

**POSITIVE LIQUID SEALING**

Shaft positively sealed from pumpage with gaskets and O-rings. (excluding S-group)

**HEAVY DUTY CASING**

Rugged foot-mounted design to resist external forces and vibration. Casing wall designed to withstand high working pressures with minimum distortion. Both suction and discharge connections in lower half, allowing removal of upper half casing for inspection or removal of complete rotating element without disturbing piping or driver.

**LARGE INLET AREAS**

Reduce NPSH requirement and assure smooth flow to impeller eye for efficient, quiet operation.

# Maximum Interchangeability

Entire 3410 product line utilizes just five shafts and two bearing assemblies.

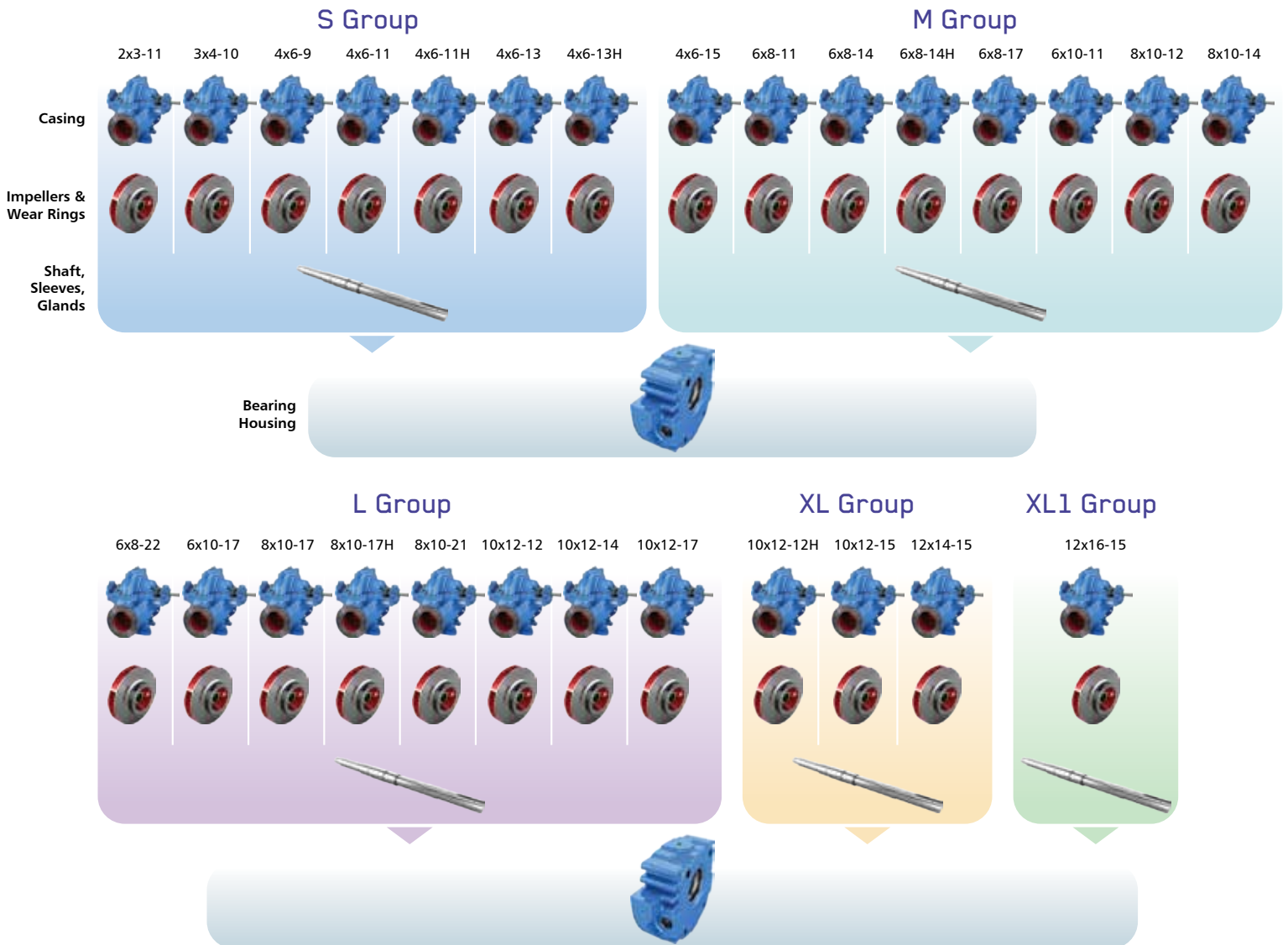

# Optional Features

## RENEWABLE IMPELLER WEARING RINGS

Available as an option on all sizes.  
Locked on impeller hub with set screws.

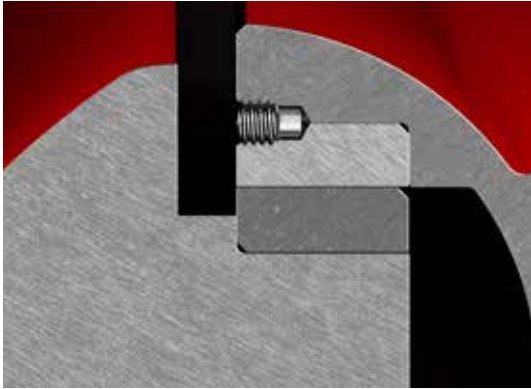

## WATER COOLED BEARINGS

If you need to lower bearing temperatures this option will help keep bearings cool in the harshest environments



## TOUGH BASEPLATES

Several robust baseplate solutions available including a one-piece cast iron baseplate with drip collection chamber, tapped drain connection, and opening for grouting.



Model 3410 V

## VERTICAL VERSATILITY

Goulds Model 3410 is available in a vertical configuration (3410 V). This arrangement is ideal for applications with limited space such as shipboard service. A rugged fabricated steel frame supports the pump and driver, providing a machined fit for positive alignment when using standard P-base or C-Face motors.

# Dimensions

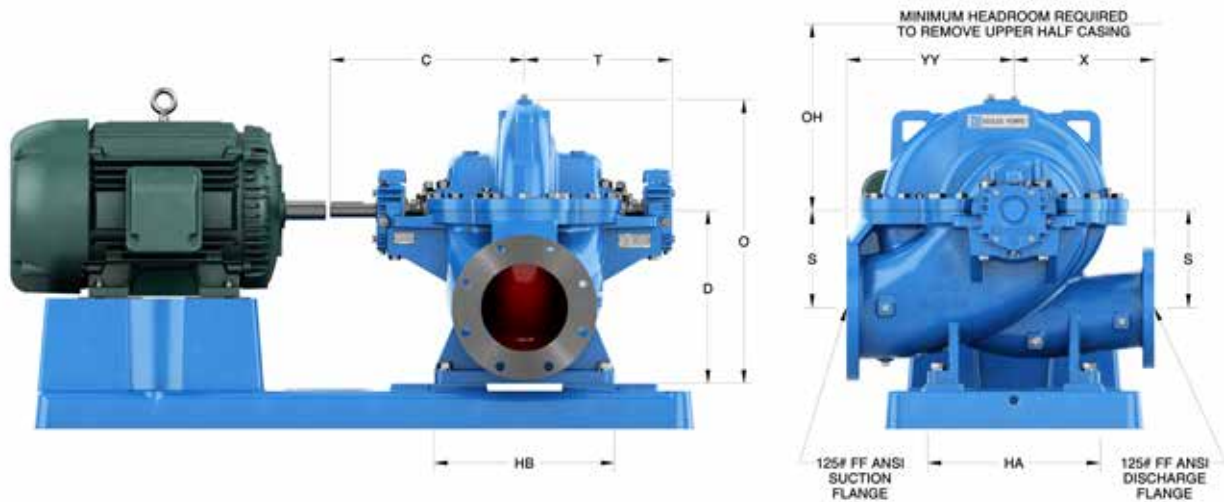

DIMENSIONS DETERMINED BY PUMP												
Frame Group	Pump Size	C	T	D	O	OH	S	X	YY	HA	HB	Wt. Lbs (kg)
S	2x3-11	14.62 (371)	11.76 (209)	11.50 (292)	18.38 (467)	12.38 (314)	7.25 (184)	7.50 (190)	9.00 (229)	12.00 (305)	12.50 (318)	330 (150)
	3x4-10				18.91 (480)	12.75 (324)	7.00 (178)	9.00 (229)	10.50 (267)			333 (151)
	4x6-9				17.88 (454)	10.88 (276)	6.00 (152)	8.50 (216)	10.00 (254)			334 (152)
	4x6-11/H				19.22 (488)	13.25 (336)	6.00 (152)	10.50 (267)	12.38 (314)			410 (186)
	4x6-13/H				20.59 (523)	15.88 (403)	6.00 (152)	11.00 (279)	13.25 (336)			472 (215)
M	4x6-15	18.00 (457)	13.88 (353)	16.00 (406)	25.88 (657)	17.38 (441)	9.50 (241)	10.00 (254)	14.50 (368)	16.00 (406)	16.75 (425)	637 (290)
	6x8-11				26.44 (672)	16.00 (406)	9.00 (229)	12.00 (305)	14.50 (368)			692 (315)
	6x8-14/H				25.75 (654)	16.75 (425)	9.00 (229)	13.00 (330)	15.50 (394)			665 (302)
	6x8-17				27.88 (708)	20.62 (524)	9.00 (229)	14.25 (362)	15.75 (400)			885 (402)
	8x10-11				25.50 (648)	15.25 (391)	9.00 (229)	13.25 (336)	17.00 (432)			737 (335)
	8x10-12				27.31 (694)	17.38 (441)	8.75 (222)	13.00 (330)	19.50 (495)			858 (398)
	8x10-14				28.50 (724)	19.50 (495)	8.75 (222)	13.88 (352)	19.50 (495)			996 (453)
L	6x8-22	21.00 (533)	16.28 (414)	22.00 (559)	40.50 (1029)	22.50 (572)	13.50 (343)	20.50 (520)	22.00 (559)	22.50 (572)	18.00 (457)	1495 (680)
	6x10-17				33.88 (860)	20.62 (524)	11.00 (279)	16.50 (419)	20.00 (508)			1015 (461)
	8x10-17/H				34.06 (865)	20.88 (530)	10.00 (254)	16.50 (419)	20.00 (559)			1286 (585)
	8x10-21				36.31 (922)	24.88 (632)	13.00 (330)	17.00 (432)	20.30 (521)			1520 (691)
	10x12-12				34.88 (886)	19.12 (486)	11.00 (279)	14.00 (356)	21.00 (533)			1229 (559)
	10x12-14				34.00 (864)	19.25 (489)	11.00 (279)	16.75 (426)	21.00 (533)			1410 (641)
	10x12-17				37.50 (952)	30.75 (781)	11.50 (292)	17.62 (448)	22.50 (572)			1709 (777)
XL	10x12-12H	23.19 (589)	17.64 (448)	24.00 (610)	39.50 (1003)	21.75 (552)	13.00 (330)	15.00 (381)	22.00 (559)	22.50 (572)	27.00 (686)	2168 (985)
	10x12-15				38.00 (965)	21.50 (532)	13.00 (330)	16.00 (406)	24.00 (610)			1720 (782)
	12x14-15				36.50 (927)	21.75 (552)	13.00 (330)	18.00 (457)	25.00 (635)			2500 (1136)
XL1	12x16-15	25.78 (655)	20.15 (512)	26.26 (667)	42.20 (1072)	23.75 (603)	13.00 (330)	17.00 (432)	24.49 (622)	22.50 (572)	27.00 (686)	2200 (997)

All dimensions are in inches (mm) and are not to be used for construction or installation purposes.  
 Sizes 2x3-11 and 4x6-11/H, 3x4-10, 8x10-21 & 6x8-22 are furnished with 250# FF discharge flange as standard.  
 Standard rotation is right hand (CW). Optional rotation is left hand (CCW).  
 Steel casings will have 150# or 300# flanges.

# Specifications

## General

Pump shall be single stage, double suction design. Materials shall be 316 stainless steel trim or all 316SS. High efficiency, heavy duty design and maintenance features shall be of primary importance as described in following specifications.

## Casing

Shall be horizontally split with upper and lower halves bolted together. Flanged suction and discharge connections shall be located in lower half. Removal of upper half shall permit inspection, maintenance or removal of entire rotating element without disturbing suction or discharge piping or driver. Seats for stuffing box bushing shall be cast and bored integrally with lower half casing. Casing shall be supported by integrally cast feet. Upper half shall have taps for seal piping, priming and vents. Lower half shall have taps for gauges and draining. Casing shall have permanently fixed stainless steel nameplate.

## Casing Flanges

For iron casings the flanges shall be ASME 125# flat face as standard with ASME 250# flat face or DIN 1092-2 PN16 available as an option. For steel casings the flanges shall be ASME 150# flat face as standard with ASME 300# flat face or DIN 1092-2 PN25 available as an option.

## Impeller

Shall be enclosed, double suction to provide hydraulic balance, and cast in one piece. Exterior surfaces shall be machined, interior water ways hand finished. Shall be dynamically balanced and keyed to shaft.

## Wearing Rings

Case wear rings shall be supplied to maintain proper running clearance with impeller hubs and to minimize leakage between suction and discharge chambers of casing. Shall be held in position by anti-rotation pins. Impeller shall be designed to accept impeller wear rings. Impeller rings shall be held in position by axial set screws.

## Shaft

Shall have as short a span as possible to minimize deflection and vibration. Shall be completely sealed by gaskets between the shaft sleeves and impeller hubs to assure shaft is completely dry during operation.

## Shaft Sleeves (Except S Group)

Shall be held in position by sleeve nuts located outside the stuffing box area. Shall be key driven at the impeller end. An O-ring seal shall be provided to prevent leakage between sleeves and sleeve nuts.

## Stuffing Boxes

Shall have tapped openings for flushing either from casing or from outside source. Glands shall be split so it will be unnecessary to unbolt gland halves when repacking box.

## Sealing Options

Mechanical seals shall be furnished as the standard sealing method. Factory installed mechanical seals feature enlarged stuffing box bores for improved seal lubrication and cooling. A wide variety of mechanical seals (including cartridge and split type) are readily available for maximum sealing flexibility. Packing is available as an option.

## Bearing Housings

Seats shall be cast and bored integrally with lower half casing to assure accurate alignment of rotating assembly without need for external adjustment.

## Bearings

Double row ball bearing shall be provided on thrust end; single row deep groove ball bearing on coupling end. Thrust bearing shall be held in position on shaft with tapered snap ring and locked in bearing housing. Radial bearing shall be free to float axially in housing to take radial load only. Housings shall be completely sealed by labyrinth seals to exclude moisture and debris making units suitable for outdoor installation. If grease lubricated shall be equipped with reliefs to prevent over lubrication.

## Bedplate and Coupling

Bedplate shall be cast iron with drip collection chamber, tapped drain connection and opening for grouting. Flexible coupling shall be supplied.



# 3410

## The Most Complete Line of Double Suction Pumps in the Industry



### Model 3410

- Capacities to 8,000 GPM (1817 m<sup>3</sup>/h)
- Heads to 570 Ft. TDH (174 m)
- Temperatures to 350° F (177° C)
- Working Press. to 250 PSI (1724 kPa)

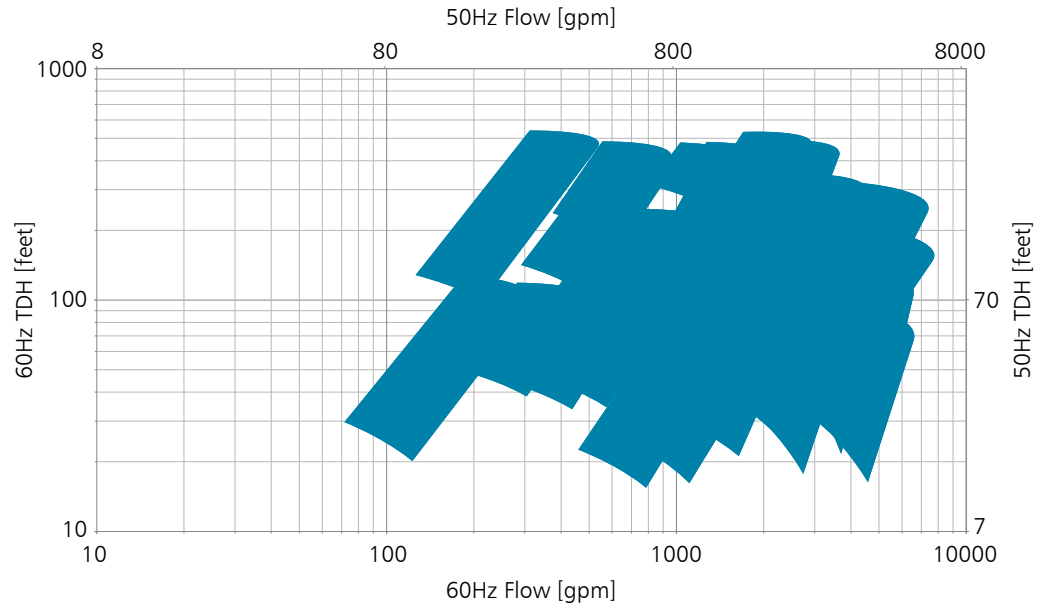

### 3409

- Capacities to 12,000 GPM (2725 m<sup>3</sup>/h)
- Heads to 850 Ft. TDH (259 m)
- Temperatures to 250° F (120° C)
- Working Press. to 400 PSI (2758 kPa)

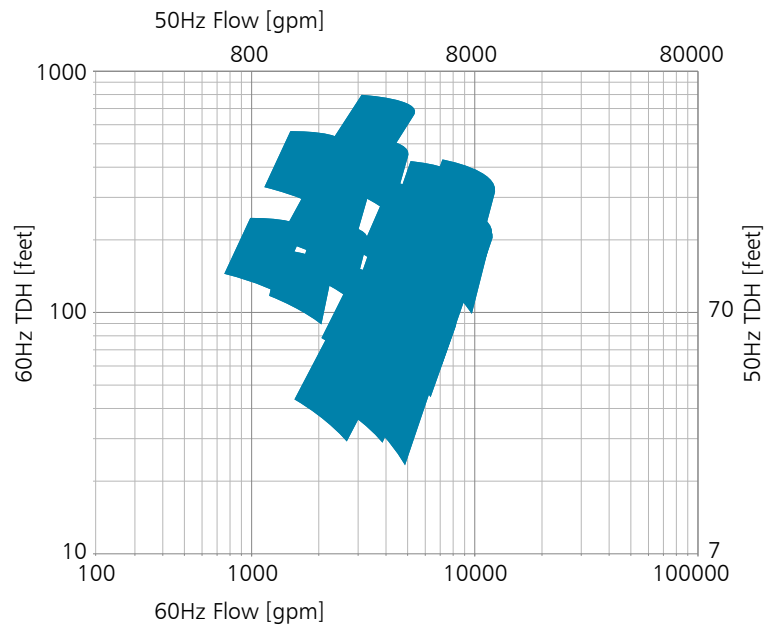



**3420**

- Capacities to 74,000 GPM (16,807 m3/h)
- Heads to 400 Ft. TDH (122 m)
- Temperatures to 275° F (135° C)
- Working Press. to 200 PSI (1379 kPa)

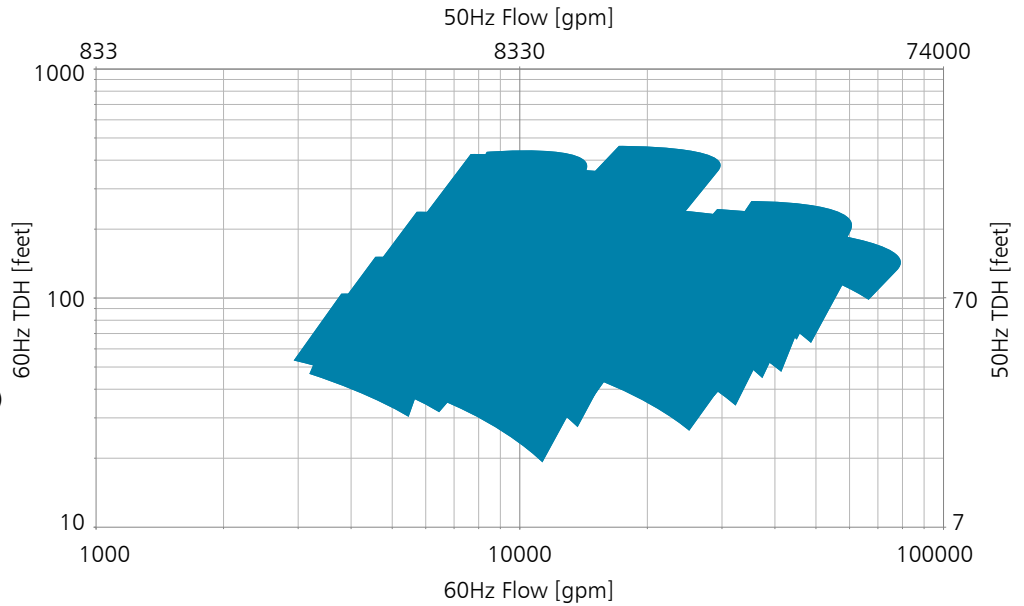

**3498**

- Capacities to 68,000 GPM (15,445 m3/h)
- Heads to 700 Ft. TDH (213 m)
- Temperatures to 275° F (135° C)
- Working Press. to 250 PSI (1724 kPa)

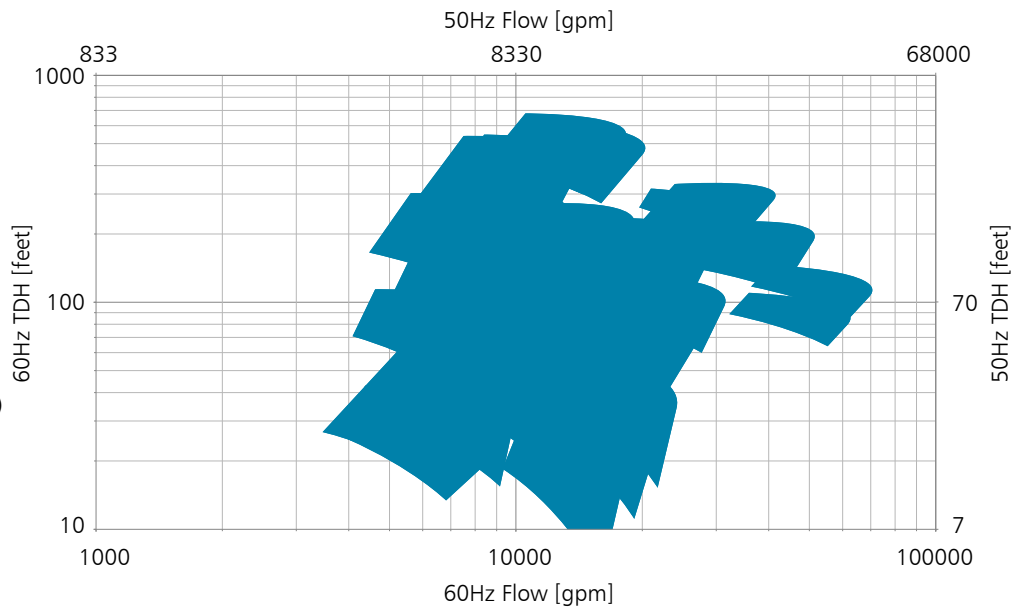

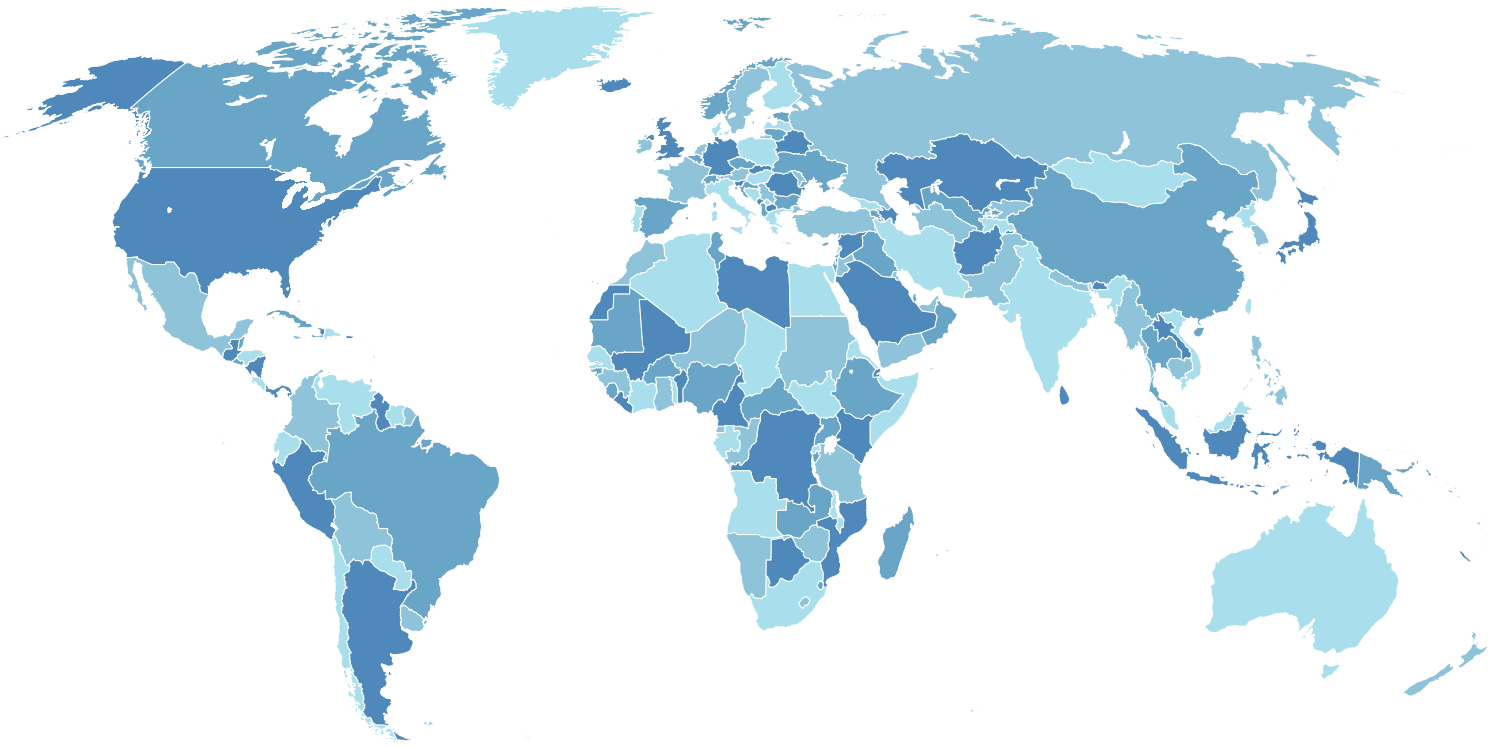

Visit [www.ittproservices.com](http://www.ittproservices.com) & [www.gouldspumps.com](http://www.gouldspumps.com) to find nearest service, sales, and manufacturing locations



— An ITT Brand

240 Fall Street  
Seneca Falls, NY 13148  
Phone: 315.568.2811  
Fax: 315.568.2418  
[www.gouldspumps.com](http://www.gouldspumps.com)

© 2024 ITT Goulds Pumps Inc.

B.3410.en-US.2024-05