

# GOULDS PUMPS

## Installation, Operation and Maintenance Instructions



**ANSI FAMILY**



**ITT**



# FOREWORD

This manual provides instructions for the Installation, Operation, and Maintenance of the ITT Goulds Models 3196, CV 3196, HT 3196, LF 3196, NM 3196, 3198, and 3796. This manual covers the standard product plus common options that are available. For special options, supplemental instructions are supplied. **This manual must be read and understood before installation and start-up.**

This instruction manual covers several different pump models that all have a common power end. Most assembly, disassembly, and inspection procedures are the same for all the pumps. However, where there are differences, they are called out separately within the manual. The design, materials, and workmanship incorporated in the construction of ITT Goulds pumps makes them capable of giving long, trouble-free service. The life and satisfactory service of any mechanical unit, however, is enhanced and extended by correct application, proper installation, periodic inspection, condition monitoring and careful maintenance. This instruction manual was prepared to assist operators in understanding the construction and the correct methods of installing, operating, and maintaining these pumps.

**ITT Goulds shall not be liable for physical injury, damage, or delays caused by a failure to observe the instructions for installation, operation, and maintenance contained in this manual.**



*When installed in potentially explosive atmospheres, the instructions that follow the Ex symbol must be followed. Personal injury and/or equipment damage may occur if these instructions are not followed. If there is any question regarding these requirements or if the equipment is to be modified, please contact a ITT Goulds representative before proceeding.*

**Warranty is valid only when genuine ITT Goulds parts are used.**

Use of the equipment on a service other than stated in the order will nullify the warranty, unless written approval is obtained in advance from ITT Goulds Pumps.

Supervision by an authorized ITT Goulds representative is recommended to assure proper installation.

Additional manuals can be obtained by contacting your local ITT Goulds representative or by calling 1-800-446-8537.

## **THIS MANUAL EXPLAINS**

- **Proper Installation**
- **Start-up Procedures**
- **Operation Procedures**
- **Routine Maintenance**
- **Pump Overhaul**
- **Trouble Shooting**
- **Ordering Spare or Repair Parts**



# TABLE OF CONTENTS

PAGE		SECTION
9		SAFETY 1
13		GENERAL INFORMATION 2
21		INSTALLATION 3
37		OPERATION 4
47		PREVENTIVE MAINTENANCE 5
55		DISASSEMBLY & REASSEMBLY 6
111		SPARE AND REPAIR PARTS 7
119		APPENDIX 8
119	I	Frame Lubrication Conversion
123	II	Installation Instructions for ITT Goulds ANSI B15.1 Coupling Guards
127	III	Set Up and Alignment
131	IV	Labyrinth Seal Installation Instructions
133	V	C-Face Adapter Installation Instructions
135	VI	3198 Teflon® Sleeve Field Replacement Procedure
137	VII-1	Double Row Angular Contact Bearing Installation Instructions
139	VII-2	Duplex Angular Contact Bearing Installation Instructions
141	VIII	Inpro Labyrinth Oil Seal Installation Instructions



## IMPORTANT SAFETY NOTICE

*To: Our Valued Customers*

User safety is a major focus in the design of our products. Following the precautions outlined in this manual will minimize your risk of injury.

ITT Goulds pumps will provide safe, trouble-free service when properly installed, maintained, and operated.

Safe installation, operation, and maintenance of ITT Goulds Pumps equipment are an essential end user responsibility. This *Pump Safety Manual* identifies specific safety risks that must be considered at all times during product life. Understanding and adhering to these safety warnings is mandatory to ensure personnel, property, and/or the environment will not be harmed. Adherence to these warnings alone, however, is not sufficient — it is anticipated that the end user will also comply with industry and corporate safety standards. Identifying and eliminating unsafe installation, operating and maintenance practices is the responsibility of all individuals involved in the installation, operation, and maintenance of industrial equipment.

Please take the time to review and understand the safe installation, operation, and maintenance guidelines outlined in this Pump Safety Manual and the Instruction, Operation, and Maintenance (IOM) manual. Current manuals are available at [www.gouldspumps.com/literature\\_ioms.html](http://www.gouldspumps.com/literature_ioms.html) or by contacting your nearest Goulds Pumps sales representative.

**These manuals must be read and understood before installation and start-up.**

For additional information, contact your nearest Goulds Pumps sales representative or visit our Web site at [www.gouldspumps.com](http://www.gouldspumps.com).

# SAFETY WARNINGS

Specific to pumping equipment, significant risks bear reinforcement above and beyond normal safety precautions.

---

 **WARNING**

---

A pump is a pressure vessel with rotating parts that can be hazardous. Any pressure vessel can explode, rupture, or discharge its contents if sufficiently over pressurized causing death, personal injury, property damage, and/or damage to the environment. All necessary measures must be taken to ensure over pressurization does not occur.

---

 **WARNING**

---

Operation of any pumping system with a blocked suction and discharge must be avoided in all cases. Operation, even for a brief period under these conditions, can cause superheating of enclosed pumpage and result in a violent explosion. All necessary measures must be taken by the end user to ensure this condition is avoided.

---

 **WARNING**

---

The pump may handle hazardous and/or toxic fluids. Care must be taken to identify the contents of the pump and eliminate the possibility of exposure, particularly if hazardous and/or toxic. Potential hazards include, but are not limited to, high temperature, flammable, acidic, caustic, explosive, and other risks.

---

 **WARNING**

---

Pumping equipment Instruction, Operation, and Maintenance manuals clearly identify accepted methods for disassembling pumping units. These methods must be adhered to. Specifically, applying heat to impellers and/or impeller retaining devices to aid in their removal is strictly forbidden. Trapped liquid can rapidly expand and result in a violent explosion and injury.

ITT Goulds Pumps will not accept responsibility for physical injury, damage, or delays caused by a failure to observe the instructions for installation, operation, and maintenance contained in this Pump Safety Manual or the current IOM available at [www.gouldspumps.com/literature](http://www.gouldspumps.com/literature).



# SAFETY

## DEFINITIONS

Throughout this manual the words **WARNING**, **CAUTION**, **ELECTRICAL**, and **ATEX** are used to indicate where special operator attention is required.

**Observe all Cautions and Warnings highlighted in this Pump Safety Manual and the IOM provided with your equipment.**



### **WARNING**

Indicates a hazardous situation which, if not avoided, could result in death or serious injury.

**Example:** Pump shall never be operated without coupling guard installed correctly.

---



### **CAUTION**

Indicates a hazardous situation which, if not avoided, could result in minor or moderate injury.

**Example:** Throttling flow from the suction side may cause cavitation and pump damage.

---



### **ELECTRICAL HAZARD**

Indicates the possibility of electrical risks if directions are not followed.

**Example:** Lock out driver power to prevent electric shock, accidental start-up, and physical injury.

---



When installed in potentially explosive atmospheres, the instructions that follow the Ex symbol must be followed. Personal injury and/or equipment damage may occur if these instructions are not followed. If there is any question regarding these requirements or if the equipment is to be modified, please contact an ITT Goulds Pumps representative before proceeding.







**Example:**  Improper impeller adjustment could cause contact between the rotating and stationary parts, resulting in a spark and heat generation.













---



## GENERAL PRECAUTIONS

### WARNING

A pump is a pressure vessel with rotating parts that can be hazardous. Hazardous fluids may be contained by the pump including high temperature, flammable, acidic, caustic, explosive, and other risks. Operators and maintenance personnel must realize this and follow safety measures. Personal injuries will result if procedures outlined in this manual are not followed. ITT Goulds Pumps will not accept responsibility for physical injury, damage or delays caused by a failure to observe the instructions in this manual and the IOM provided with your equipment.

General Precautions		
WARNING		NEVER APPLY HEAT TO REMOVE IMPELLER. It may explode due to trapped liquid.
WARNING		NEVER use heat to disassemble pump due to risk of explosion from tapped liquid.
WARNING		NEVER operate pump without coupling guard correctly installed.
WARNING		NEVER run pump below recommended minimum flow when dry, or without prime.
WARNING		ALWAYS lock out power to the driver before performing pump maintenance.
WARNING		NEVER operate pump without safety devices installed.
WARNING		NEVER operate pump with discharge valve closed.
WARNING		NEVER operate pump with suction valve closed.
WARNING		DO NOT change service application without approval of an authorized ITT Goulds Pumps representative.
WARNING		<p><b>Safety Apparel:</b></p> <ul style="list-style-type: none"> <li>♦ Insulated work gloves when handling hot bearings or using bearing heater</li> <li>♦ Heavy work gloves when handling parts with sharp edges, especially impellers</li> <li>♦ Safety glasses (with side shields) for eye protection</li> <li>♦ Steel-toed shoes for foot protection when handling parts, heavy tools, etc.</li> <li>♦ Other personal protective equipment to protect against hazardous/toxic fluids</li> </ul>
WARNING		<p><b>Receiving:</b></p> <p>Assembled pumping units and their components are heavy. Failure to properly lift and support equipment can result in serious physical injury and/or equipment damage. Lift equipment only at specifically identified lifting points or as instructed in the current IOM. Current manuals are available at <a href="http://www.gouldspumps.com/literature_ioms.html">www.gouldspumps.com/literature_ioms.html</a> or from your local ITT Goulds Pumps sales representative. Note: Lifting devices (eyebolts, slings, spreaders, etc.) must be rated, selected, and used for the entire load being lifted.</p>
WARNING		<p><b>Alignment:</b></p> <p>Shaft alignment procedures must be followed to prevent catastrophic failure of drive components or unintended contact of rotating parts. Follow coupling manufacturer's coupling installation and operation procedures.</p>

<b>General Precautions</b>		
<b>WARNING</b>		Before beginning any alignment procedure, make sure driver power is locked out. Failure to lock out driver power will result in serious physical injury.
<b>CAUTION</b>		<b>Piping:</b> Never draw piping into place by forcing at the flanged connections of the pump. This may impose dangerous strains on the unit and cause misalignment between pump and driver. Pipe strain will adversely effect the operation of the pump resulting in physical injury and damage to the equipment.
<b>WARNING</b>		<b>Flanged Connections:</b> Use only fasteners of the proper size and material.
<b>WARNING</b>		Replace all corroded fasteners.
<b>WARNING</b>		Ensure all fasteners are properly tightened and there are no missing fasteners.
<b>WARNING</b>		<b>Startup and Operation:</b> When installing in a potentially explosive environment, please ensure that the motor is properly certified.
<b>WARNING</b>		Operating pump in reverse rotation may result in contact of metal parts, heat generation, and breach of containment.
<b>WARNING</b>		Lock out driver power to prevent accidental start-up and physical injury.
<b>WARNING</b>		The impeller clearance setting procedure must be followed. Improperly setting the clearance or not following any of the proper procedures can result in sparks, unexpected heat generation and equipment damage.
<b>WARNING</b>		If using a cartridge mechanical seal, the centering clips must be installed and set screws loosened prior to setting impeller clearance. Failure to do so could result in sparks, heat generation, and mechanical seal damage.
<b>WARNING</b>		The coupling used in an ATEX classified environment must be properly certified and must be constructed from a non-sparking material.
<b>WARNING</b>		Never operate a pump without coupling guard properly installed. Personal injury will occur if pump is run without coupling guard.
<b>WARNING</b>		Make sure to properly lubricate the bearings. Failure to do so may result in excess heat generation, sparks, and / or premature failure.
<b>CAUTION</b>		The mechanical seal used in an ATEX classified environment must be properly certified. Prior to start up, ensure all points of potential leakage of process fluid to the work environment are closed.
<b>CAUTION</b>		Never operate the pump without liquid supplied to mechanical seal. Running a mechanical seal dry, even for a few seconds, can cause seal damage and must be avoided. Physical injury can occur if mechanical seal fails.
<b>WARNING</b>		Never attempt to replace packing until the driver is properly locked out and the coupling spacer is removed.
<b>WARNING</b>		Dynamic seals are not allowed in an ATEX classified environment.
<b>WARNING</b>		DO NOT operate pump below minimum rated flows or with suction and/or discharge valve closed. These conditions may create an explosive hazard due to vaporization of pumpage and can quickly lead to pump failure and physical injury.

<b>General Precautions</b>		
<b>WARNING</b>		Ensure pump is isolated from system and pressure is relieved before disassembling pump, removing plugs, opening vent or drain valves, or disconnecting piping.
<b>WARNING</b>		<b>Shutdown, Disassembly, and Reassembly:</b> Pump components can be heavy. Proper methods of lifting must be employed to avoid physical injury and/or equipment damage. Steel toed shoes must be worn at all times.
<b>WARNING</b>		The pump may handle hazardous and/or toxic fluids. Observe proper decontamination procedures. Proper personal protective equipment should be worn. Precautions must be taken to prevent physical injury. Pumpage must be handled and disposed of in conformance with applicable environmental regulations.
<b>WARNING</b>		Operator must be aware of pumpage and safety precautions to prevent physical injury.
<b>WARNING</b>		Lock out driver power to prevent accidental startup and physical injury.
<b>CAUTION</b>		Allow all system and pump components to cool before handling them to prevent physical injury.
<b>CAUTION</b>		If pump is a Model NM3171, NM3196, 3198, 3298, V3298, SP3298, 4150, 4550, or 3107, there may be a risk of static electric discharge from plastic parts that are not properly grounded. If pumped fluid is non-conductive, pump should be drained and flushed with a conductive fluid under conditions that will not allow for a spark to be released to the atmosphere.
<b>WARNING</b>		Never apply heat to remove an impeller. The use of heat may cause an explosion due to trapped fluid, resulting in severe physical injury and property damage.
<b>CAUTION</b>		Wear heavy work gloves when handling impellers as sharp edges may cause physical injury.
<b>CAUTION</b>		Wear insulated gloves when using a bearing heater. Bearings will get hot and can cause physical injury.

## ATEX Considerations and Intended Use

Special care must be taken in potentially explosive environments to ensure that the equipment is properly maintained. This includes but is not limited to:

1. Monitoring the pump frame and liquid end temperature.
2. Maintaining proper bearing lubrication.
3. Ensuring that the pump is operated in the intended hydraulic range.

The ATEX conformance is only applicable when the pump unit is operated within its intended use. Operating, installing or maintaining the pump unit in any way that is not covered in the Instruction, Operation, and Maintenance manual (IOM) can cause serious personal injury or damage to the equipment. This includes any modification to the equipment or use of parts not provided by ITT Goulds Pumps. If there is any question regarding the intended use of the equipment, please contact an ITT Goulds representative before proceeding.

Current IOMs are available at [www.gouldspumps.com/en-US/Tools-and-Resources/Literature/IOMs/](http://www.gouldspumps.com/en-US/Tools-and-Resources/Literature/IOMs/) or from your local ITT Goulds Pumps Sales representative.

All pumping unit (pump, seal, coupling, motor and pump accessories) certified for use in an ATEX classified environment, are identified by an ATEX tag secured to the pump or the baseplate on which it is mounted. A typical tag would look like this:

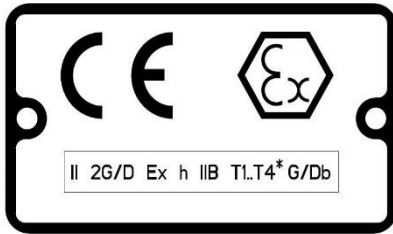

The CE and the Ex designate the ATEX compliance. The code below reads as follows:

<b>Code</b>	<b>Max permissible surface temperature °C (°F)</b>	<b>Max permissible liquid temperature °C (°F)</b>
T1	450 (842)	372 (700)
T2	300 (572)	277 (530)
T3	200 (392)	177 (350)
T4	135 (275)	113 (235)
T5	100 (212)	Option not available
T6	85 (185)	Option not available

The code classification marked on the equipment must be in accordance with the specified area where the equipment will be installed. If it is not, do not operate the equipment and contact your ITT Goulds Pumps sales representative before proceeding.

### ISO 80079-37:2016 Section 5.7

Recommended bearing replacement interval (based on L10 life) = 17,520 hours of operation.

## PARTS



The use of genuine Goulds parts will provide the safest and most reliable operation of your pump. ITT Goulds Pumps ISO certification and quality control procedures ensure the parts are manufactured to the highest quality and safety levels.







Please contact your local Goulds representative for details on genuine Goulds parts.

---

# GENERAL INFORMATION

<b>PUMP DESCRIPTION</b> . . . . .	<b>13</b>
<b>PARTS COMMONALITY</b> . . . . .	<b>15</b>
<b>NAMEPLATE INFORMATION</b> . . . . .	<b>18</b>
<b>RECEIVING THE PUMP</b> . . . . .	<b>19</b>
Storage Requirements . . . . .	19
Handling . . . . .	19

## PUMP DESCRIPTION

Model	Pump Description	Size Groups	No. of Sizes
 3196	<p>The model is based on 5 power ends and 29 hydraulic pump sizes.</p> <p>The 3196 is a horizontal overhung, open impeller, centrifugal pump that meets the requirements of ANSI B73.1.</p>	STX MTX LTX XLT-X X-17	5 15 15 5 4
 CV 3196	<p>The model is based on four power ends and seven hydraulic pump sizes.</p> <p>The CV 3196 is a horizontal overhung, recessed impeller, centrifugal pump. It is specifically designed to handle bulky or fibrous solids, air or gas entrained liquids, or shear sensitive liquids.</p>	STX MTX LTX XLT-X	1 4 5 1
 HT 3196	<p>The model HT 3196 is based on 4 power ends and 28 hydraulic pump sizes.</p> <p>The HT 3196 is a horizontal, centerline mounted, overhung, open impeller, centrifugal pump that meets the requirements of ANSI B73.1</p>	STX MTX LTX XLTX	6 16 17 5
 LF 3196	<p>The model is based on 3 power ends and 4 hydraulic pump sizes.</p> <p>The LF 3196 is a horizontal overhung, open impeller, centrifugal pump that meets the requirements of ANSI B73.1. It is designed specifically for low flow high head applications.</p>	STX MTX LTX	2 2 2
 NM 3196	<p>The model is based on 2 power ends and 13 hydraulic pump sizes.</p> <p>The NM 3196 is a horizontal overhung, open impeller, centrifugal pump that meets the requirements of ANSI B73.1. It is made of a fiber reinforced vinylester to handle severe corrosives.</p>	STX MTX	5 8
 3198	<p>The model is based on 2 power ends and 4 hydraulic pump sizes.</p> <p>The 3198 is a horizontal overhung, open impeller, centrifugal pump that meets the requirements of ANSI B73.1. It is made of a Teflon® lined ductile iron to handle severe corrosives.</p>	STX MTX	1 3
 3796	<p>The model is based on 3 power ends and 8 hydraulic pump sizes.</p> <p>The 3796 is a horizontal overhung, self priming, open impeller, centrifugal pump.</p>	STX MTX LTX	2 6 6

**This Page Intentionally Left Blank**



## ANSI Family Parts Commonality

All of ITT Goulds Pumps horizontal ANSI pumps are based on the same power end. All of the metallic units share the same stuffing box covers and seal chambers. The non-metallic units all have unique casings, impellers, and seal chambers. The chart on the following pages demonstrates the parts commonality and the relationship between the model lines.

2

**Model**

**Casing**

**Impeller**

**3196**



The casing is top centerline discharge and self-venting. The gasket is fully confined. An integral foot support is used for maximum resistance to misalignment and distortion from piping loads. ANSI flat faced serrated flanges are standard. ANSI class 150 raised face serrated, ANSI class 300 flat face serrated, and ANSI class 300 raised face serrated are available.



The impeller is fully open and threaded to the shaft. The threads are sealed from the pumpage by a Teflon® O-ring for the 3196 and 3796. The HT 3196 uses a Graphite O-ring.

**3796**

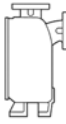

The casing is top centerline discharge and self-venting. It has an integrally cast priming chamber that allows the pump to evacuate air to prime itself. The gasket is fully confined. An integral foot support is used for maximum resistance to misalignment and distortion from piping loads. ANSI class 150 raised face serrated flanges are available as an option. The casing comes with a provision to accept an immersion heater to keep the liquid in the priming chamber from freezing in outdoor applications.

**HT 3196**



The casing is top centerline discharge, self-venting, and centerline mounted. The casing support is used for maximum resistance to misalignment and distortion from thermal piping loads. The centerline mounted casing maintains vertical alignment at elevated temperatures. ANSI class 300 raised face serrated flanges are standard.

**CV 3196**



The casing is tangential discharge and available with optional connections for venting, flushing, and solids cleanout. The gasket is fully confined. An integral foot support is used for maximum resistance to misalignment and distortion from piping loads. ANSI class 150 flat face serrated flanges are standard on all sizes.



The impeller is fully open and recessed from the casing. It has curved vanes and is threaded to the shaft. The threads are sealed from the pumpage by a Teflon® O-ring.

**LF 3196**



The casing is top centerline discharge and self-venting. The gasket is fully confined. An integral foot support is used for maximum resistance to misalignment and distortion from piping loads. ANSI class 150 raised face serrated flanges are standard on 4, 8, and 10" sizes. ANSI class 300 raised face serrated flange are standard on the 13" size and optional on 4, 8, and 10" sizes.



The impeller is fully open with radial vanes and balance holes. The impeller is threaded to the shaft and sealed from the pumpage by a Teflon® O-ring.

**NM 3196**



The casing is top centerline discharge and self-venting. It is constructed from a fiber reinforced vinylester that is ribbed for strength. It is sealed using a Viton® O-ring as standard. An integral foot support is used for maximum resistance to misalignment and distortion from piping loads. ANSI class 150 flat face flanges are standard.



The impeller is fully open and threaded to the shaft. It is a fiber reinforced vinylester over a Hastelloy C insert that provides support and rigidity to the impeller while securing it to the shaft. The threads are sealed from the pumpage by a Teflon® O-ring.

**3198**



The casing is top centerline discharge and self-venting. The ductile iron casing is lined with PFA Teflon® for corrosion resistance and is offered with ANSI class 150 raised face flanges. The casing gasket is a Teflon® envelope with a compressible filler that provides a positive seal with low bolt torque.



The impeller is fully open and threaded to the shaft. It is constructed of a PFA Teflon® covered steel insert. The insert provides support and rigidity to the impeller while securing it to the shaft. The threads are sealed from the pumpage by a Teflon® O-ring.



The 3196, CV 3196, HT 3196, LF 3196, and 3796 are available with a stuffing box cover designed for packing and BigBore™ or TaperBore™ PLUS seal chambers for improved performance of mechanical seals.

An optional dynamic seal is available which uses a repeller to pump liquid out of the stuffing box while the pump operates. A static seal prevents leakage when the pump is shutdown.

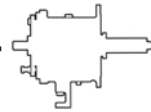

**Frame Adapter** - The ductile iron frame adapter has a machined rabbet fit to the seal chamber/ stuffing box cover and a precision dowel pin fit to the bearing frame. The 3198 frame adapter has the same features but different dimensions to accommodate the pump's Teflon® lining.

**Power End** - The oil level is viewed through a sight glass. Optional oil cooling is provided by a finned tube cooler. A finned tube cooler is standard with HT 3196. Flood oil lubrication is standard. The power end is sealed with non-metallic labyrinth seals. No machining is required to convert from oil to grease or oil mist lubrication. Regresable bearings and oil mist lubrication are optional.

**Shaft** - The shaft is available with or without a sleeve. When supplied with a Teflon® sleeve, the 3198 shaft is knurled under the sleeve to provide a positive drive for the sleeve.

**Bearings** - The inboard bearing carries only radial loads. It is free to float axially in the frame. The outboard bearing is shouldered and locked to the shaft and housing to enable it to carry radial and thrust loads. All fits are precision machined to industry standards. The inboard bearing is a single row deep groove ball bearing. The outboard bearing is a double row angular contact bearing, except for the LTX which uses a pair of single row angular contact ball bearings mounted back-to-back.



The NM 3196 is supplied with a fiber reinforced vinyl ester backplate to accommodate a clamped outside single seal. The backplate is also available with an internal bypass flush. An optional bolt on seal chamber is available for conventional back-to-back double seals.



The 3196 is supplied with a PFA Teflon® lined backplate to accommodate a clamped outside single seal. Also available for the backplate is a bolt-on metallic seal chamber for conventional back-to-back double seals. An optional PFA Teflon® lined standard bore stuffing box cover is available for conventional single clamped seat inside or outside seals. For cartridge seals, an ETFE Tefzel® lined BigBore™ seal chamber is available.

# NAMEPLATE INFORMATION

Every pump has two ITT Goulds nameplates that provide information about the pump. The tags are located on the casing and bearing frame.

When ordering spare parts, you will need to identify pump model, size, serial number, and the item number of required parts. Information can be taken from the pump casing tag. Item numbers can be found in this manual.

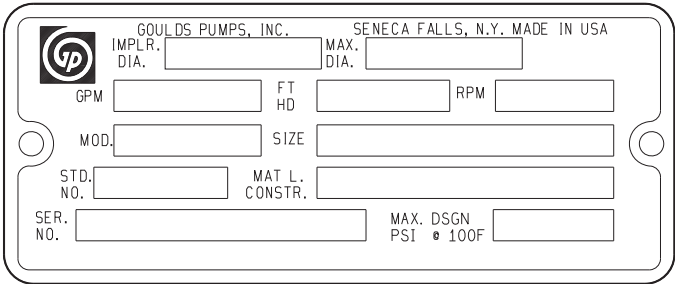
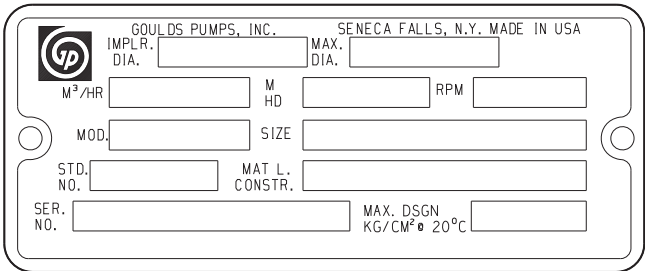
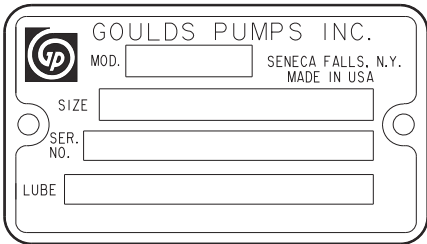
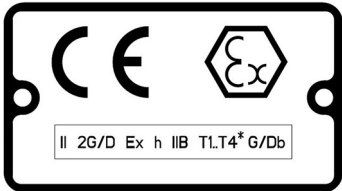
Description	Fig. No.	Example
<p><b>Pump Casing Tag</b> - provides information about the pump's hydraulic characteristics. Note the format of the pump size: Discharge x Suction - Nominal maximum Impeller Diameter in inches. (Example: 2x3-8)</p> <p>(Figs. 1 &amp; 2).</p>	<p><b>Fig. 1</b> <b>English</b></p>	 <p>The English nameplate includes fields for: IMPLR. DIA., MAX. DIA., GPM, FT HD, RPM, MOD., SIZE, STD. NO., MAT L. CONSTR., SER. NO., and MAX. DSGN PSI @ 100F.</p>
	<p><b>Fig. 2</b> <b>Metric</b></p>	 <p>The Metric nameplate includes fields for: IMPLR. DIA., MAX. DIA., M<sup>3</sup>/HR, M HD, RPM, MOD., SIZE, STD. NO., MAT L. CONSTR., SER. NO., and MAX. DSGN KG/CM<sup>2</sup> @ 20°C.</p>
<p><b>Bearing Frame Tag</b> - provides information on the lubrication system used (Fig. 3).</p>	<p><b>Fig. 3</b></p>	 <p>The Bearing Frame Tag includes fields for: MOD., SIZE, SER. NO., LUBE, and SENECA FALLS, N.Y. MADE IN USA.</p>
<p><b>ATEX Tag</b> - If applicable, your pump unit may have the following ATEX tag affixed to the pump and/or baseplate. See the Safety section for a description of the symbols and codes (Fig. 4).</p>	<p><b>Fig. 4</b></p>	 <p>The ATEX tag features the CE mark, the Ex symbol, and the code II 2G/D Ex h IIB T1.T4* G/Db.</p>

## RECEIVING THE PUMP

Inspect the pump as soon as it is received. Carefully check that everything is in good order. Make notes of damaged or missing items on the receipt and freight bill. File any claims with the transportation company as soon as possible.

### STORAGE REQUIREMENTS

**Short Term:** (Less than 6 months) ITT Goulds normal packaging procedure is designed to protect the pump during shipping. Upon receipt, store in a covered and dry location.

**Long Term:** (More than 6 months) Preservative treatment of bearings and machined surfaces will be required. Rotate shaft several times every 3 months. Refer to driver and coupling manufacturers for their long term storage procedures. Store in a covered dry location.

**NOTE:** Long term storage treatment can be purchased with the initial pump order or can be applied to pumps already in the field that were not treated at the factory. This service can be supplied by contacting your local ITT Goulds sales representative.

### HANDLING



#### WARNING

**Pump and components are heavy. Failure to properly lift and support equipment could result in serious physical injury or damage to pumps. Steel toed shoes must be worn at all times.**

Use care when moving pumps. Lifting equipment must be able to adequately support the entire assembly. Hoist bare pump using a suitable sling, under the suction flange and bearing frame. Base-plate mounted units are moved with slings under the pump casing and driver. Refer to Figs. 4-7 for examples of proper lifting techniques.



#### WARNING

**Refer to the Installation section of this manual for detailed instructions for lifting a Polyshield® ANSI Combo with installed equipment. Never lift a Polyshield® ANSI Combo with pump and motor mounted using the procedure shown in Fig. 5 and Fig. 6.**

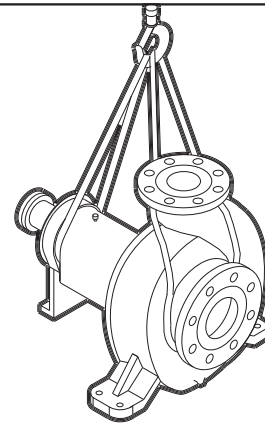

Fig. 4

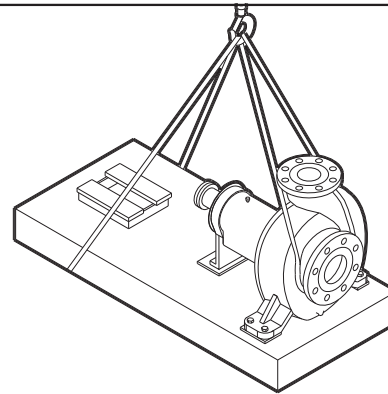

Fig. 5

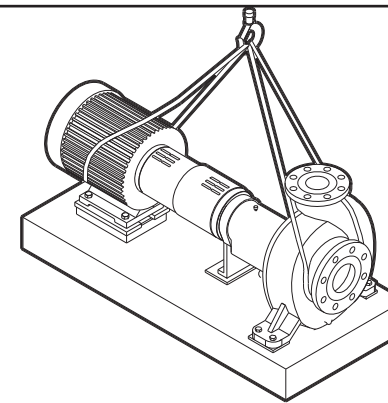

Fig. 6

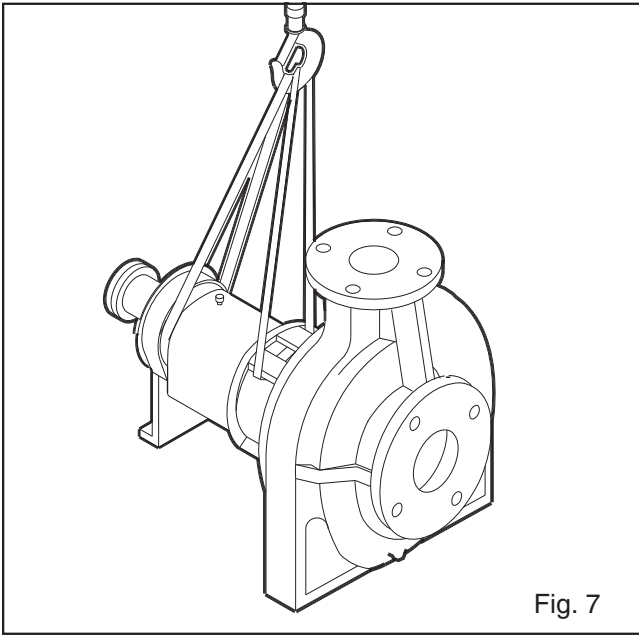

Fig. 7

**NOTE:** When lifting the NM 3196 or metallic units with integral suction flanges that do not have a way to secure the strap on the suction flange, the strap shown in Figures 4-6 around the suction flange should be secured around the frame adapter (Fig. 7).

# INSTALLATION

- BASEPLATE INSPECTION . . . . . 21**
- SITE / FOUNDATION . . . . . 21**
- LEVEL BASEPLATE . . . . . 22**
  - Cast Iron / PermaBase™ / Fab. Steel . . . . . 22
  - Feature Fab. Steel / Advantage Base . . . . . 23
  - Stilt Mounted . . . . . 23
  - Spring Mounted . . . . . 24
  - Polyshield® ANSI Combo . . . . . 25
- BASEPLATE LEVELING WORKSHEET . . . . . 30**
- ALIGNMENT . . . . . 31**
  - Alignment Checks . . . . . 31
  - Alignment Criteria . . . . . 31
- ALIGNMENT TROUBLESHOOTING . . . . . 32**
- GROUT BASEPLATE . . . . . 33**
  - Alignment Check . . . . . 33
- PIPING . . . . . 33**
  - General . . . . . 33
  - Suction Piping . . . . . 34
  - Discharge Piping . . . . . 36
  - Final Piping Check . . . . . 36



*Equipment that is to be installed in a potentially explosive environment must be done so in accordance with the following installation instructions.*

## BASEPLATE INSPECTION

1. Remove all equipment.
2. Completely clean the underside of baseplate. It is sometimes necessary to coat the underside of the baseplate with an epoxy primer. This may have been purchased as an option.
3. Remove the rust preventative solution from the machined pads with an appropriate solution.

## SITE / FOUNDATION

A pump should be located near the supply of liquid and have adequate space for operation, maintenance, and inspection.

Baseplate mounted pumps are normally grouted on a concrete foundation, which has been poured on a solid footing.

The foundation must be able to absorb any vibration and to form a permanent, rigid support for the pumping unit. The location and size of the foundation bolt holes are shown on the outline assembly drawing, provided with the pump data package.



**All equipment being installed must be properly grounded to prevent unexpected static electric discharge. This includes ensuring that the PFA lined pumps (Model 3198) and the non-metallic liquid end pumps (Model NM3196) are pumping fluids that are conductive. If not, a static electric discharge may occur when the pump is drained and disassembled for maintenance purposes.**

Foundation bolts commonly used are sleeve type (Fig. 8) and J type (Fig. 9). Both designs permit movement for final bolt adjustment.

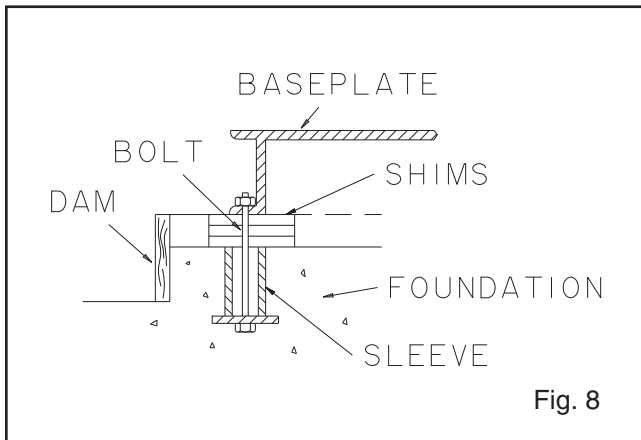

Fig. 8

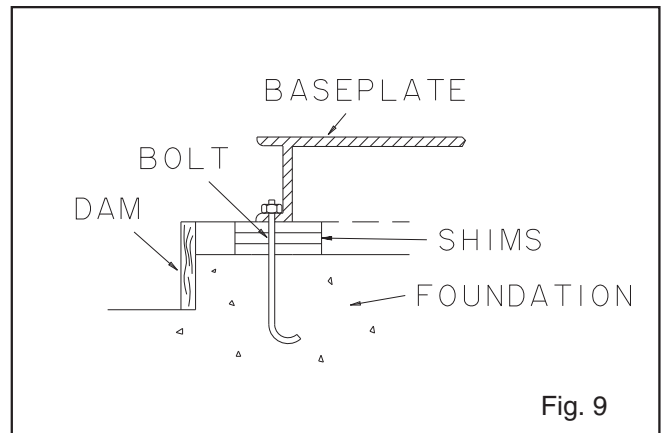

Fig. 9

1. Inspect foundation for dust, dirt, oil, chips, water, etc. and remove any contaminants. Do not use oil-based cleaners as grout will not bond to it.
2. Prepare the foundation in accordance with the grout manufacturer's recommendations.

## LEVEL BASEPLATE

### CAST IRON/PERMABASE™/FAB. STEEL

1. Place two sets of wedges or shims on the foundation, one set on each side of every foundation bolt. The wedges should extend .75 in. (20mm) to 1.50 in. (40mm) above foundation, to allow for adequate grouting. This will provide even support for the baseplate once it is grouted.
2. Remove water and/or debris from anchor bolt holes/sleeves prior to grouting. If the sleeve type bolts are being used, fill the sleeves with packing or rags to prevent grout from entering.
3. Carefully lower baseplate onto foundation bolts.
4. Level baseplate to within .125 in. (3.2mm) over length of the baseplate and to within .088 in. (1.5mm) over the width of the base by adjusting wedges.
5. A level should be placed across the pump mounting pads and the motor mounting pads.
6. Hand tighten the bolts.

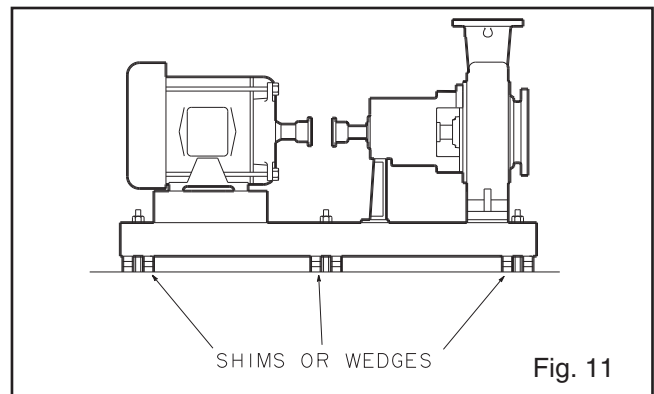
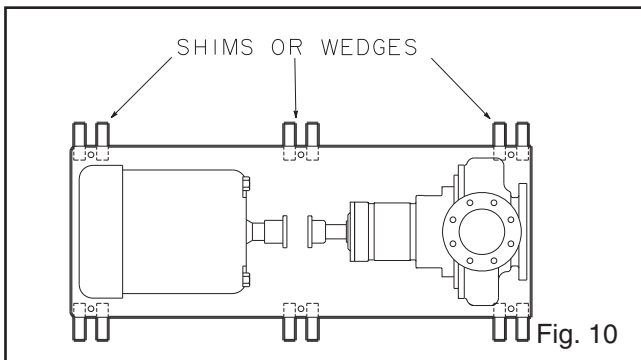



## FEATURE FAB. STEEL / ADVANTAGE BASE (BASEPLATES PROVIDED WITH VERTICAL LEVELING ADJUSTERS)

1. Coat the jack screws with an anti-seizing compound to allow for easy removal after the grout has been cured.
2. Cut round circular plates from bar stock to set the jack screws on. The edges of the plates should be chamfered to reduce stress concentrations.
3. Set the baseplate on the foundation and use the four corner jack screws to raise the baseplate off the foundation 0.75" to 1.5". The two center jack screws should not be touching the foundation.

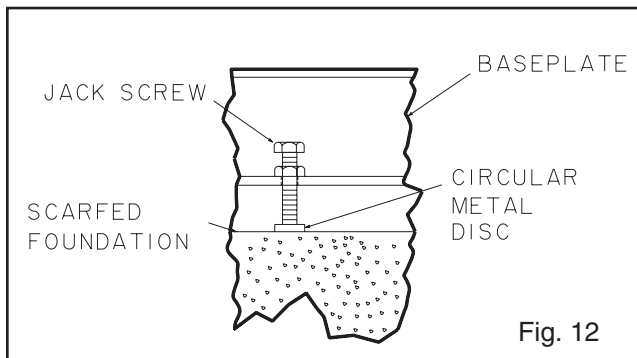

Fig. 12

4. Place two machinist levels on the motor pads, one lengthwise on a single motor pad, and another across the ends of both motor pads (Fig. 13).

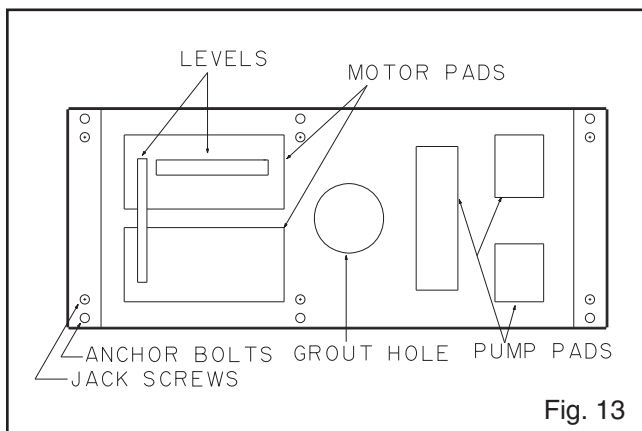

Fig. 13

**NOTE: When using a machinist level, it is important that the surface being leveled is free of all contaminants, such as dust, to ensure an accurate reading.**

5. Level the motor pads as close to zero as possible, in both directions, by adjusting the four jack screws.
6. Next, turn down the center jack screws so that they are resting on their metal discs on the foundation.

7. Place the two levels on the pump pads, one lengthwise on a single pump pad, and another across the middle of both pump pads (Fig. 14).

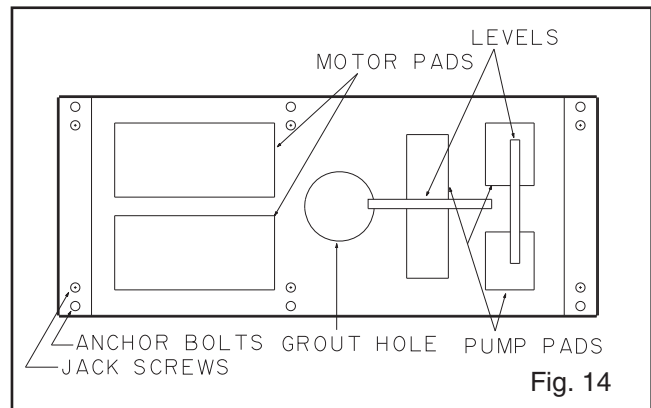

Fig. 14

8. Level the pump pads as close to zero as possible, in both directions, by adjusting the jack screws.
9. Install the anchor bolts until they are hand tight.
10. Return the levels to the motor pads and check the level measurements.
11. Adjust the jack screws and anchor bolts, if necessary, until all level measurements are within the design requirements of 0.002 in./ft.
12. When taking readings, center the level over the pad being measured.

**NOTE: The Baseplate Leveling Worksheet provided may be used when taking readings.**

## Stilt Mounted

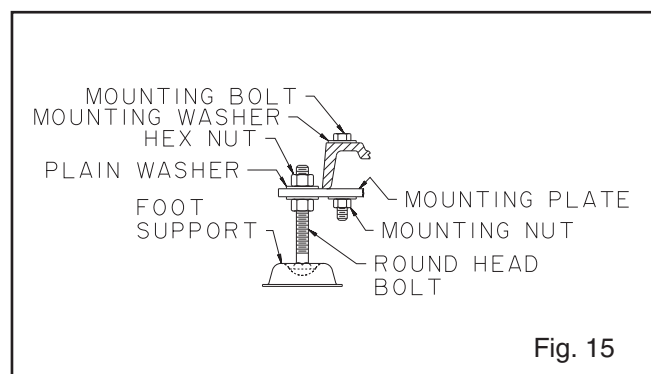

Fig. 15

1. Raise or support the baseplate above the foundation or floor.
2. Determine the desired baseplate height above the floor, referenced to the stilt mounting flange.

3. Set the bottom adjusting nuts and jamnuts on each stilt to the desired height.
4. Insert a washer between the bottom adjusting nut and the baseplate.
5. Install each stilt, holding it in place with another washer and the top adjusting nut. Finish by installing the top jam nut.
6. Once all four stilts have been installed, lower the unit making sure each stilt bolt head settles into its floor cup.
7. Level the baseplate while making final height adjustments. Adjust the baseplate height by loosening the top jam nut and adjusting nut. Change the height by moving the lower adjusting nut. When the baseplate is level, tighten the top adjusting nuts and then snug the lower and upper jam nuts.

**NOTE: Suction and discharge piping must be individually supported. The stilt mounted baseplate is not designed to support any static pipe loads.**

### Spring Mounted

1. Raise or support the baseplate above the foundation or floor. Be sure to allow enough room under the baseplate to install the spring assemblies.
2. Set the bottom adjusting nuts on each spring stud to the desired height.
3. Insert a washer between the bottom adjusting nut and the spring follower. Install a spring and another follower. Install this subassembly from the bottom of the baseplate.
4. Install the upper half of the spring assembly consisting of a follower, a spring, another follower, and a flat washer. Now install the top adjusting nut and jam nut. Tighten finger tight.
5. Repeat steps 1 thru 4 for all the spring assemblies.
6. Once all the springs have been installed, lower the unit on to the foundation pads.
7. Level the baseplate while making final height adjustments. Adjust the baseplate height by loosening the top jam nut and adjusting nut. Change the height by moving the lower adjusting nut. When the baseplate is level, tighten the top adjusting nuts just enough to make sure the top springs are not loose in their followers and then snug the lower and upper jam nuts.

**NOTE: The foundation pads are supplied by the customer. They are to be 16-20 micro-inch surface finish 316 stainless steel plate.**

**NOTE: Suction and discharge piping must be individually supported. The spring mounted baseplates are designed to support piping loads developed by thermal expansion only.**

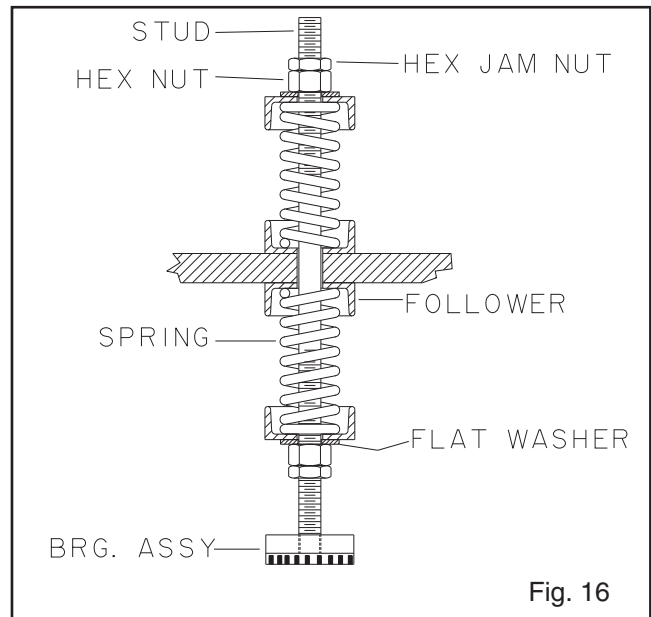

Fig. 16

# Polyshield® ANSI Combo

## Installation, Operation, and Maintenance Instructions

### Safety Considerations

Several important general precautions are listed below:

1. Do not remove the Polyshield® ANSI Combo from its shipping pallet until you are ready to hoist it onto its location.
2. Do not subject the Polyshield® ANSI or Custom Combo to rough handling or unnecessary mechanical shock.
3. Do not attempt to lift the Polyshield® ANSI Combo by any means other than that which is prescribed in these procedures.
4. Do not use hammer blows or other impact loading to adjust the positioning of the Polyshield® ANSI Combo. Do not pry against the Polyshield® mounting block when moving the motor during shaft alignment.
5. Do not attempt to transport, handle, or install a Polyshield® ANSI Combo when ambient temperature is below -50° F (-45° C).
6. Do not operate a pump installed on a Polyshield® ANSI Combo at process fluid temperatures in excess of 300° F (150° C) with polymer mounting pads and 500° F with alloy mounting pads unless prior approval from ITT Industries is obtained in writing.

**NOTE: Always coordinate installation activity with operations personnel, and follow all plant safety requirements and applicable safety and health laws, directives and regulations.**

### Overview



#### WARNING



#### CAUTION

**Observance of proper handling procedures during installation is extremely important to prevent damage to the Polyshield® ANSI Combo. While polymer concrete possesses inherent high strength, subjecting it to impact or bending loads through rough handling or improper lifting or mounting may result in irreparable damage to the Polyshield® ANSI Combo as well as damage to the mounted equipment or injury to personnel.**

### Application

The polymer concrete material used in the manufacture of the Polyshield® ANSI Combo has been formulated for application in a wide range of corrosive fluid handling services. The material is not, however, universally corrosion resistant. A comprehensive corrosion guide is available. (Refer to Pricebook Page 766.7. It is strongly recommended that this bulletin be reviewed prior to specifying or installing a Polyshield® Product.

The Polyshield® ANSI Combo is also suitable for application in a wide range of fluid process temperatures, specifically, -50° F to 300° F (-45° C to 150° C). Depending on the configuration of the pump that is to be mounted on the Polyshield®, fluid process temperature in excess of 300° F (150° C) may be permissible. Contact your ITT Goulds Pumps representative for assistance in determining acceptability of a specific application.

### Storage

This section addresses the storage procedures for the Polyshield® ANSI Combo only. When storing Polyshield® ANSI Combos and pump assemblies, it is important that the proper storage procedures for the pump be observed as well. Refer to the Installation, Operation and Maintenance Instructions (IOM) for the particular ITT Goulds pump that is mounted on your Polyshield® product.

Polyshield® normal packaging is designed to protect the Polyshield® ANSI Combo during shipment and handling from the time it is manufactured at the factory to installation at the end user's jobsite. If the Polyshield® Combo is to be stored for a period of time prior to installation, it is recommended that the following procedures be followed:

- a. Leave the Polyshield® ANSI Combo strapped to its wooden shipping pallet.
- b. Place the pallet on a solid, dry, level surface in a location where the ANSI Combo cannot be struck by passing fork trucks, falling objects, etc. Make sure the pallet does not rock.
- c. Do not stack heavy objects on top of the Polyshield® ANSI Combo.

- d. If the Polyshield® ANSI Combo is to be stored in an outdoor location, cover the Polyshield® completely with a tarpaulin or dark plastic sheeting to prevent UV degradation of the surface.

**NOTE:** UV degradation (bleaching) of the polymer concrete is the normal result of exposure to sunlight. This phenomenon is purely a visible change in the color of the material, which in no way compromises the performance or corrosion resistance characteristics of the Polyshield®.



**WARNING**

Do not attempt to stand a Polyshield® on its end to make more efficient use of storage space. Neither the Polyshield® Combo nor the strapping that holds the Polyshield® Combo to its wooden pallet have been designed for vertical storage. Severe personal injury or death, as well as irreparable damage to the Polyshield® Combo may result if the Combo tips over.

**Lifting Polyshield® Combo Units and Polyshield® Combo / Pump Assemblies**



**CAUTION**

Polyshield® units should be transported via fork truck to the area of their intended installation on the wooden pallets on which they were shipped. Never transport a Polyshield® unit over a long distance or over rough terrain while suspended from slings.

Only trained personnel should do lifting. Pumps and motors often have integral lifting eyes or eye bolts. These are intended for use in lifting the individual pieces of equipment. Do not use these features to lift a Polyshield® Combo / pump assembly.

**Lifting**

The following procedures are recommended for lifting Polyshield® ANSI Combo units:

**Polyshield® with no mounted equipment:**



**WARNING**

Do not install eyebolts in the Polyshield® thread inserts for the purpose of lifting the base. This practice imposes lateral loads on the inserts — which they were not designed to withstand.

Remove the metal shipping straps that hold the Polyshield® unit to the wooden pallet. Slip slings under each end of the Polyshield® unit as a harness (Fig. A).

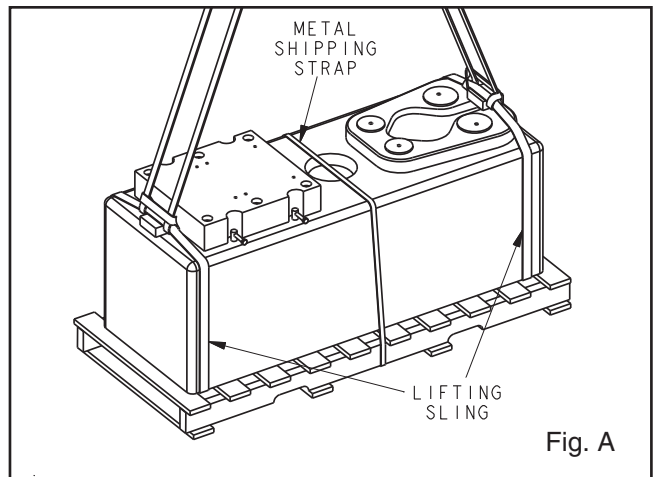

Lift the Polyshield® unit a few inches off the pallet and verify that it hangs reasonably level and that the slings are not prone to slipping out of position.



**WARNING**

Keep hands and feet out from under the Polyshield® unit during these steps. If slings slip and the unit tips over, severe personal injury or death may result, as well as irreparable damage to the Polyshield® Combo.

If the sling appears to be unstable, set the Polyshield® unit back on the pallet and reposition the slings.

After satisfactory slinging has been achieved, the Polyshield® unit may be hoisted onto its foundation. Take care not to bump the unit against fixed objects or induce any unnecessary shock loads. Lower the unit slowly over the foundation using care to center the unit over the rebar cage. Place shim packs or wedges under the Polyshield® unit at a minimum of eight total or (four [4] locations on each side) to allow for the removal of the slings. Twelve (12) total shim locations or (six [6] shim locations each side) are required for Polyshield® units exceeding 6 feet in length.

**Polyshield® with installed equipment:**

**Pump and motor installed:**

Remove the metal shipping straps that hold the Polyshield® unit to the wooden pallet. Slip slings under each end of the Polyshield® unit. This procedure is recommended up to the MTX or LTX pump units. All motors up to a 364T NEMA frame may be installed while mounted. Motor frame sizes 365Tor larger should be removed during locating and installation of the Polyshield® ANSI Combo units. Check to see that the pump suction nozzle does not interfere with the lifting sling. If the pump creates interference, it should be removed. Lift the Polyshield® ANSI Combo a few inches off the pallet and verify that it hangs reasonably level and that the slings are not prone to slipping out of position.

After satisfactory slinging has been achieved, the Polyshield® ANSI Combo may be hoisted onto its foundation. Take care not to bump the unit against fixed objects or induce any unnecessary shock loads. Lower the unit slowly over the foundation using care to center the unit over the rebar cage. Place shim packs or wedges under the Polyshield® unit at a minimum of eight total (or four [4] locations on each side) to allow for the removal of the slings. Twelve (12) total shim locations (or six [6] shim locations each side) are required for Polyshield® units exceeding 6 feet in length.

## Installation

### General Description of the Polyshield® ANSI Combo

The Polyshield® ANSI Combo is a solid, polymer concrete foundation and baseplate shell that is manufactured in versions that conform to accommodate ASME/ANSI B73.1 pumps.

Polyshield® ANSI Combo units are manufactured in five primary sizes with integral catch basins and removable motor mounting blocks.

Metallic thread inserts are provided in the mounting surface for the particular combination of pump and motor that the Combo is intended. The metallic thread inserts on the pump end are available in 316SS (18.8 CrNi stainless steel), Alloy 20 (A744, CN-7M) and Hastelloy C 276 (A494, CW-6M). Multiple motor insert patterns are also available to accommodate more than one NEMA frame size. The standard thread insert material for the motor end is 316SS (18.8 CrNi stainless steel).

Optional alloy pads are available instead of metallic inserts for requirements that call for 0.002"/ft. and or process temperatures between 301° F and 500° F.

### Polyadjust Motor Block Adjuster System

The Polyshield® ANSI Combo utilizes as standard the unique Polyshield® Polyadjust motor mounting system (Fig. B). This system is comprised of a one-piece polymer concrete motor mounting block having surface flatness and parallelism equivalent to machine steel blocks. The Polyadjust motor mounting block system incorporates the Polyloc Transverse Jack Bolt system. The Polyloc system provides transverse

motor adjustment. The side-mounted adjusters allow for shaft alignment to critical tolerances with minimal disturbance of indicators. The adjusters make contact with a solid motor mounting block not the foot of the motor.

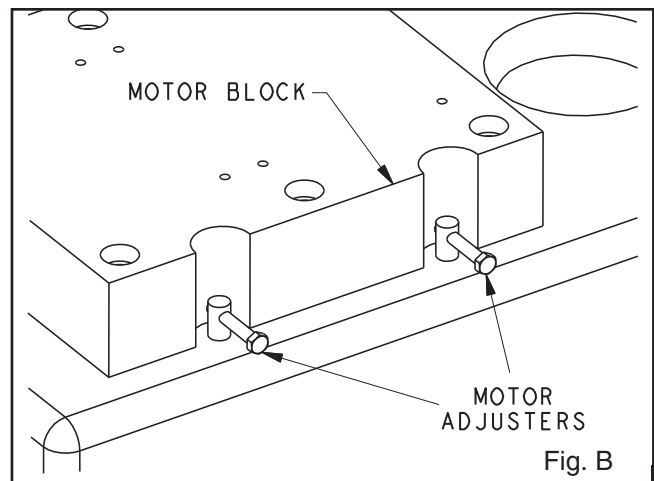

Fig. B

### Polyshield® ANSI and Custom Combos Installation Procedures (NEW CONSTRUCTION)

1. Remove laitance and form grease and oil from area where the Polyshield® ANSI Combo will be located using mechanical means, abrasive blasting, or water blasting. Remove any loose debris including fins, aggregate, or any protruding objects around the perimeter of the area where the Polyshield ANSI Combo will rest.
2. Measure the outside dimensions of the Polyshield® ANSI Combo and subtract 8" from both the width and length to determine the rebar maximum dimension, thus providing clearance from the side of the walls of the ANSI Combo.
3. Drill holes in the existing slab a minimum of four inches deep for doweling in the vertical rebar rods allowing a minimum of one inch clearance from the top of the interior of the Polyshield® ANSI Combo. Space the rebar rods of 12" centers. Remove dust and debris from dowel holes and fill with epoxy adhesive for anchoring the rebar.
4. Allow the epoxy adhesive to cure, and then install horizontal rebar rods, tying in place with wire.
5. Place the Polyshield® ANSI Combo over the rebar cage, making adjustments for proper elevation, orientation relative to piping centerlines. A qualified millwright should field verify proper position of the pump mounting pads relative to the centerline of the suction piping. Appropriate shims may be placed along the bottom edge of the Polyshield® ANSI Combo to aid in leveling. Place shim packs or wedges under the Polyshield® unit at a minimum of eight total (or four [4] locations on each side) to allow for the removal of the slings and metal lifting straps from each end. A minimum of twelve (12) total shim locations (or six [6] shim locations each side) are recommended for Polyshield® units exceeding 7 feet in length.

6. Check and verify the dimensions again before the grouting procedure begins.
7. A low slump standard concrete mix is suitable for filling the Polyshield® ANSI Combo in new construction.
8. Seal around the outside bottom perimeter of the Polyshield® ANSI Combo with a fast setting hydraulic cement. Two brand name hydraulic cements are: **Water Plug Hydraulic Cement** and **Dam-It Non Shrink Hydraulic Cement**
9. Pour the concrete mixture through the grout fill port on the top of the Polyshield® ANSI Combo using a concrete vibrator to ensure proper flow of the concrete. Do not over vibrate as excessive vibrating leads to larger aggregate settling which will result in a weak mix.
10. Pour the concrete to the bottom edge of the grout fill port.
11. Remove any loose debris from around edges of the grout fill port.
12. Seal grout fill port with grout port plug and Polyshield® Seal Kit provided.
13. Install pump, motor, and attach lines.

## TOOLS FOR INSTALLATION

- Hammer drill with proper size bit
- Worm gear saw with diamond blade(if required)
- Rebar cutters (new installation)
- Concrete mixer
- Concrete vibrator
- Lifting device (for placing Polyshield® Foundation)
- Hand tools
- Chipping hammer
- Pressure washer or abrasive blast rig as required
- Epoxy adhesive (for setting rebar into concrete slab – new installation)
- Rebar tie wire
- Fast set cement

## Polyshield® ANSI Combo Sealing Kit Epoxy Novolac (EN) Instructions

### Each Kit contains:

- Polyshield® EN Resin
- Polyshield® EN Hardener
- Stir Sticks
- LATEX Gloves
- Instruction Sheet
- MSDS Material Safety Data Sheet

### Application Instructions:

The Polyshield® EN Sealing Kit is intended for use in (1) bonding the plug into the grout hole at the top of the combo and (2) sealing and providing chemical resistance barrier around the perimeter of pump pad.

1. All surfaces to be bonded should be thoroughly cleaned and should be free of dust, oils and contaminants. Sand surfaces to be bonded prior to use.
2. Pour Polyshield® EN Hardener into the Polyshield® Resin can. Mix well with stir stick for about two minutes.
3. Apply to properly prepared surface by stir stick or putty knife.
4. Use MEK, Xylene solvents for cleaning tools and equipment and for lightly brushing surface to provide a smooth finish.

## Safety Precautions



### WARNING

***Resin and hardener components may be irritating to the eyes and skin on contact. Vapors may cause irritation of eyes and respiratory tract. Area must be ventilated. Wear protective clothing including gloves. For details safety information, refer to the Material Safety Data Sheets of these products.***

## Polyshield® ANSI Combo Sealing Kit Vinyl Ester (VE) Instructions

### Each Kit contains:

- Polyshield® VE Resin
- Polyshield® VE Hardeners #1
- Stir Sticks
- LATEX Gloves
- Instruction Sheet
- MSDS Material Safety Data Sheet

## Application Instructions

The Polyshield® VE Sealing Kit is intended for use in (1) bonding the plug into the grout hole at the top of the combo and (2) sealing and providing chemical resistance barrier around the perimeter of pump pad.

1. All surfaces to be bonded should be thoroughly cleaned and should be free of dust, oils and contaminants. Sand surfaces to be bonded prior to use.
2. Pour Polyshield® VE Hardener #1 into the Polyshield® VE Resin can. Mix well with stir stick for about two minutes.
3. Apply to properly prepared surface by stir stick or putty knife.
4. Use MEK, Xylene solvents for cleaning tools and equipment and for lightly brushing surface to provide a smooth finish.

## Safety Precautions



### WARNING

***Resin and hardener components may be irritating to the eyes and skin on contact. Vapors may cause irritation of eyes and respiratory tract. Area must be ventilated. Wear protective clothing including gloves. For details on safety information, refer to the Material Safety Data Sheets of these products.***

Polyshield® is a registered trademark, U.S. Patent Nos. 5165651, et. al, apply.

## Shelf Life and Storage

Store resin and hardener in their unopened containers in a dry cool place away from open flames, heat or sources of ignition. Shelf life is limited to 60 days if stored in a cool, dry location.

Polyshield® Seal Kits provide sealant for every ANSI Combo. Polyshield® Seal Kits are shipped with each ANSI Combo.

**Fastener Size and Recommended Torque Values**

Fastener Standard	Fastener Nominal Size	Recommended Torque <sup>1</sup> lb.-ft.
SAE	$\frac{5}{16}$	6
	$\frac{3}{8}$	10
	$\frac{7}{16}$	18
	$\frac{1}{2}$	27
	$\frac{5}{8}$	53
	$\frac{3}{4}$	94
	$\frac{7}{8}$	152
	1	228

<sup>1</sup> Torque values shown for SAE fasteners are based on dry threads at 75% of proof load for ASTM307 Grades A and B (SAE Grade 1) fasteners.

For lubricated, plated, or PTFE coated threads, use 75% of torque values shown.

# BASEPLATE LEVELING WORKSHEET

## LEVEL MEASUREMENTS

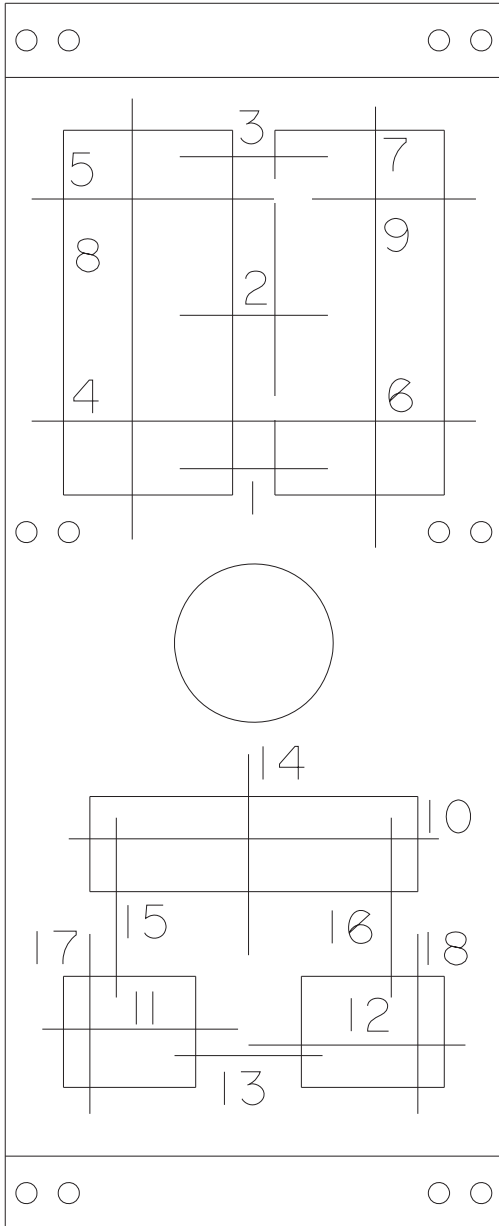

- 1) \_\_\_\_\_
- 2) \_\_\_\_\_
- 3) \_\_\_\_\_
- 4) \_\_\_\_\_
- 5) \_\_\_\_\_
- 6) \_\_\_\_\_
- 7) \_\_\_\_\_
- 8) \_\_\_\_\_
- 9) \_\_\_\_\_
- 10) \_\_\_\_\_
- 11) \_\_\_\_\_
- 12) \_\_\_\_\_
- 13) \_\_\_\_\_
- 14) \_\_\_\_\_
- 15) \_\_\_\_\_
- 16) \_\_\_\_\_
- 17) \_\_\_\_\_
- 18) \_\_\_\_\_



# ALIGNMENT



**Alignment procedures must be followed to prevent unintended contact of rotating parts. Follow coupling manufacturer's coupling installation and operation procedures.**



## WARNING

**Before beginning any alignment procedure, make sure driver power is locked out. Failure to lock out driver power will result in serious physical injury.**

To remove guard, refer to coupling guard assembly/disassembly instructions.

The points at which alignment is checked and adjusted are:

- **Initial Alignment** is done prior to operation when the pump and the driver are at ambient temperature.
- **Final Alignment** is done after operation when the pump and driver are at operating temperature.

Alignment is achieved by adding or removing shims from under the feet of the driver and shifting equipment horizontally as needed.

**NOTE: Proper alignment is the responsibility of the installer and user of the unit.**

Accurate alignment of the equipment must be attained. Trouble-free operation can be accomplished by following the procedures in *Appendix III*.

## ALIGNMENT CHECKS

### Initial Alignment (Cold Alignment)

- **Before Grouting Baseplate** - To ensure alignment can be obtained.
- **After Grouting Baseplate** - To ensure no changes have occurred during grouting process.
- **After Connecting Piping** - To ensure pipe strains haven't altered alignment. If changes have occurred, alter piping to remove pipe strains on pump flanges.

### Final Alignment (Hot Alignment)

- **After First Run** - To obtain correct alignment when both pump and driver are at operating temperature. Thereafter, alignment should be checked periodically in accordance with plant operating procedures.

**NOTE: Alignment check must be made if process temperature changes, piping changes and or pump service is performed.**

## ALIGNMENT CRITERIA

Good alignment is achieved when the dial indicator readings as specified in the alignment procedure are:

- .002 in. (.05 mm) Total Indicated Reading (T.I.R.) or less when the pump and driver are at operating temperature (Final Alignment)
- .0005 in. per inch of dial indicator separation for the reverse dial indicator or laser method when the pump and driver are at operating temperature (Final Alignment).

**NOTE: C-Face motor adapter installation instructions and alignment criteria are detailed in Appendix V.**

During the installation phase, however, it is necessary to set the parallel alignment in the vertical direction to a different criteria due to differences in expansion rates of the pump and driver. *Table 1* shows recommended preliminary (cold) settings for electric motor driven pumps based on different pumpage temperatures. Driver manufacturers should be consulted for recommended cold settings for other types of drivers (steam turbines, engines, etc.)

**Table 1**  
**Cold Setting of Parallel Vertical Alignment**

Pumpage Temperature	Set Driver Shaft, Inches (mm)						
	3196	CV 3196	HT 3196	LF 3196	NM 3196	3198	3796
50° F (10° C)	.002 (.05) low	.002 (.05) low	0.000	.002 (.05) low	.002 (.05) low	.002 (.05) low	.002 (.05) low
150° F (65° C)	.001 (.03) high	.001 (.03) high	0.000	.001 (.03) high	.001 (.03) high	.001 (.03) high	.001 (.03) high
250° F (120° C)	.005 (.12) high	.005 (.12) high	0.000	.005 (.12) high	.005 (.12) high	.005 (.12) high	.005 (.12) high
350° F (175° C)	.009 (.23) high	.009 (.23) high	0.000	.009 (.23) high	N/A	.009 (.23) high	.009 (.23) high
450° F (218° C)	.013 (.33) high	.013 (.33) high	0.000	.013 (.33) high	N/A	N/A	.013 (.33) high
550° F (228° C)	.017 (.43) high	.017 (.43) high	0.000	.017 (.43) high	N/A	N/A	.017 (.43) high
650° F (343° C)	.021 (.53) high	.021 (.53) high	0.000	.021 (.53) high	N/A	N/A	N/A
700° F (371° C)	.023 (.58) high	.023 (.58) high	0.000	.023 (.58) high	N/A	N/A	N/A

**NOTE:** For the HT 3196, the cold setting of parallel vertical is 0.0 for all pumpage temperatures due to centerline mounting.

## ALIGNMENT TROUBLESHOOTING

**Table 2**

Problem	Problem Cause	Remedy
Cannot obtain horizontal (Side-to-Side) alignment, angular or parallel	Driver feet bolt bound.	Loosen pump hold down bolts and slide pump and driver until horizontal alignment is achieved.
	Baseplate not leveled properly, probably twisted.	Determine which corner(s) of the baseplate are high or low and remove or add shims at the appropriate corner(s) and realign.

## GROUT BASEPLATE

1. Clean areas of baseplate that will contact grout. Do not use oil-based cleaners because grout will not bond to it. Refer to grout manufacturer's instructions.
2. Build dam around foundation. Thoroughly wet foundation (Fig. 17).

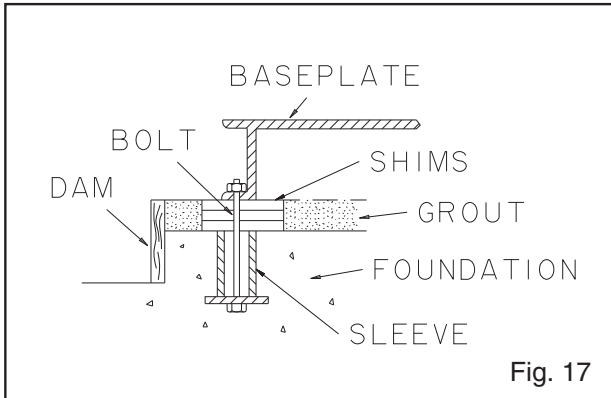

3. Pour grout through grout hole in baseplate, up to level of dam. Remove air bubbles from grout as it is poured by puddling, using a vibrator, or pumping the grout into place. Non-shrink grout is recommended.
4. Allow grout to set.

5. Fill remainder of baseplate with grout. Remove air as before (Fig. 18).

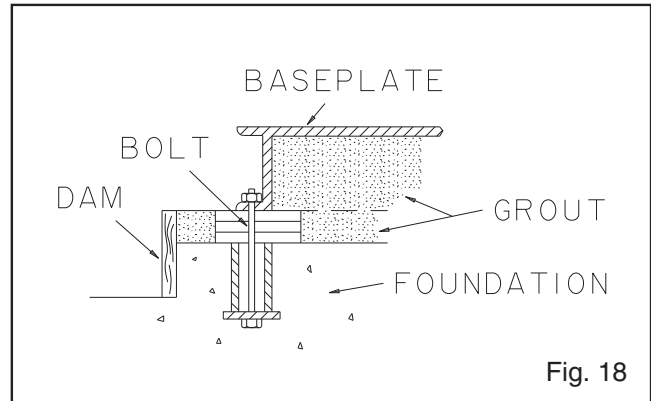

6. Allow grout to set at least 48 hours.
7. Tighten foundation bolts.

### ALIGNMENT CHECK

Re-check alignment before continuing, using methods previously described.

3

## PIPING

### GENERAL

Guidelines for piping are given in the "Hydraulic Institute Standards" available from: Hydraulic Institute, 9 Sylvan Way, Parsippany, NJ 07054-3802 and must be reviewed prior to pump installation.



### WARNING

**Never draw piping into place by forcing at the flanged connections of the pump. This may impose dangerous strains on the unit and cause misalignment between pump and driver. Pipe strain will adversely effect the operation of the pump resulting in physical injury and damage to the equipment.**

1. All piping must be supported independently of, and line up naturally with, the pump flanges.
2. Piping runs should be as short as possible to minimize friction losses.
3. **DO NOT** connect piping to pump until grout has hardened and pump and driver hold-down bolts have been tightened.

- It is suggested that expansion loops or joints, if used, be properly installed in suction and/or discharge lines when handling liquids at elevated temperatures, so linear expansion of piping will not draw pump out of alignment (Fig. 19 & 20).

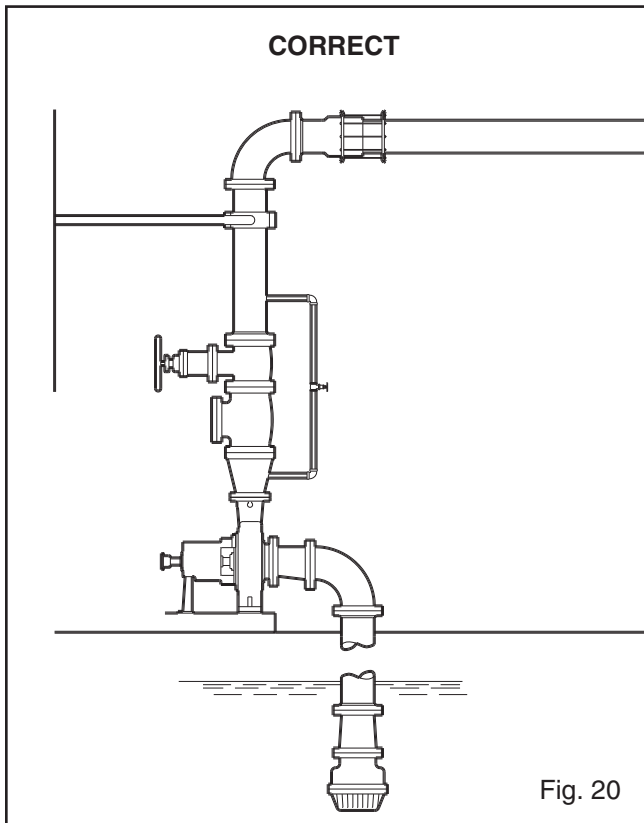
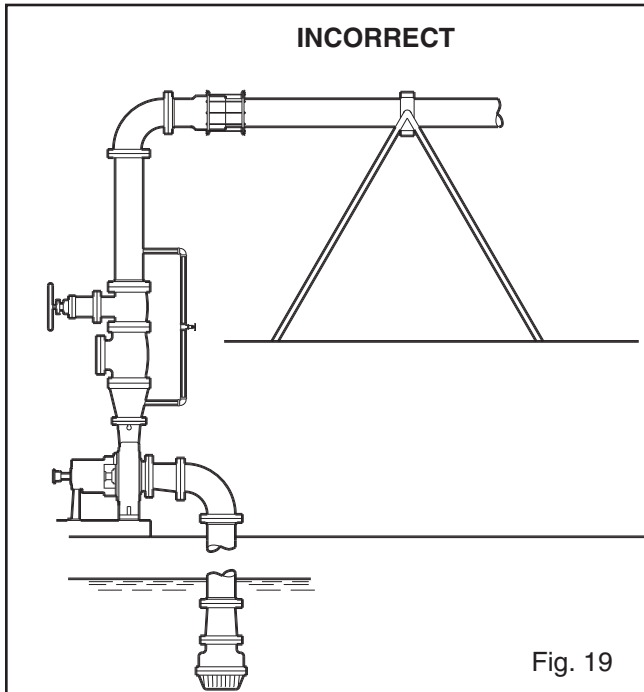

- The piping should be arranged to allow pump flushing prior to removal of the unit on services handling corrosive liquids.
- Carefully clean all pipe parts, valves and fittings, and pump branches prior to assembly.

## SUCTION PIPING



### WARNING

***NPSH<sub>A</sub> must always exceed NPSH<sub>R</sub> as shown on ITT Goulds performance curves received with order. Reference Hydraulic Institute for NPSH and pipe friction values needed to evaluate suction piping.***

Properly installed suction piping is a necessity for trouble-free pump operation. Suction piping should be flushed **BEFORE** connection to the pump.

- Use of elbows close to the pump suction flange should be avoided. There should be a minimum of two pipe diameters of straight pipe between the elbow and suction inlet. Where used, elbows should be long radius (Fig. 21).

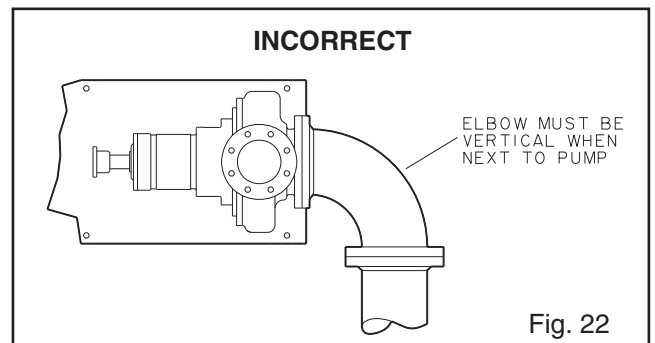
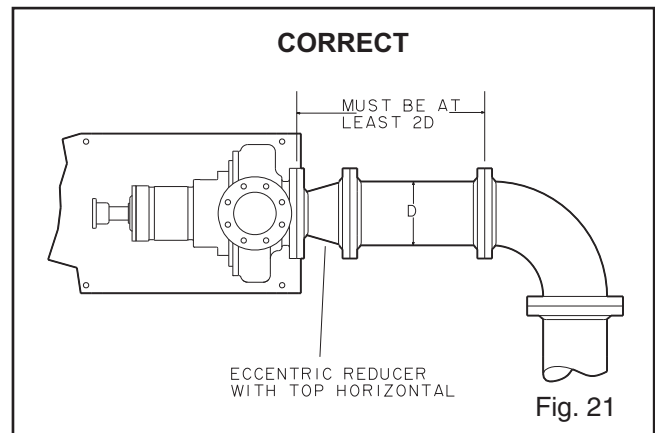

- Use suction pipe one or two sizes larger than the pump suction, with a reducer at the suction flange. **Suction piping should never be of smaller diameter than the pump suction.**

- Reducers should be eccentric at the pump suction flange with sloping side down and horizontal side at the top (Figs. 23, 24, 25).

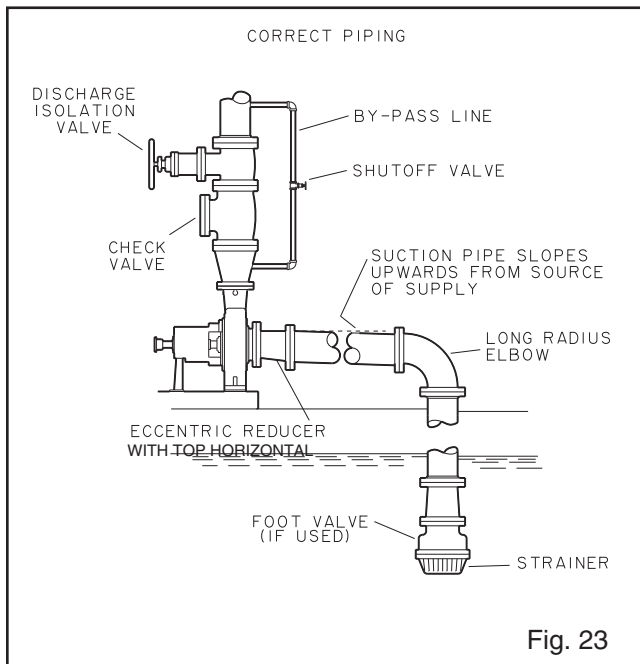

Fig. 23

**CAUTION**  
*Pump must never be throttled on suction side.*

- Suction strainers, when used, must have a net “free area” of at least three times the suction pipe area.
- Separate suction lines are recommended when more than one pump is operating from the same source of supply.

**Suction Lift Conditions**

- Suction pipe must be free from air pockets.
- Suction piping must slope upwards to pump.
- All joints must be air tight.
- A means of priming the pump must be provided, such as a foot valve, except for the 3796 self priming pump.

**Suction Head / Flooded Suction Conditions**

- An isolation valve should be installed in the suction line at least two pipe diameters from the suction to permit closing of the line for pump inspection and maintenance.
- Keep suction pipe free from air pockets.

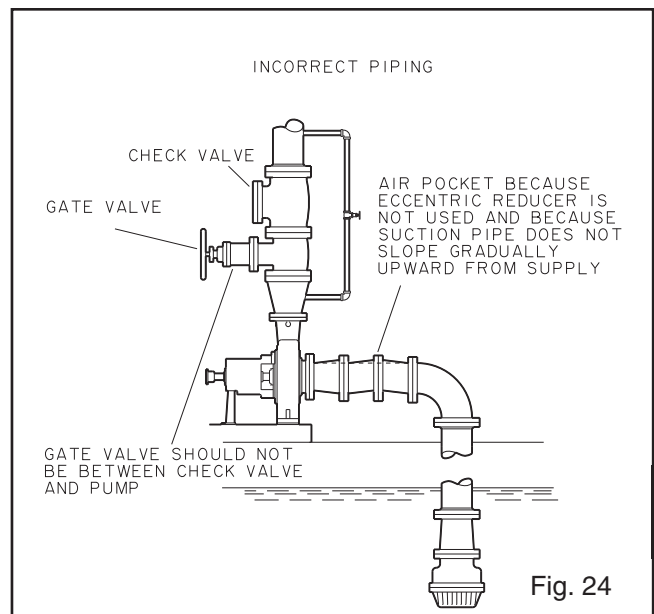

Fig. 24

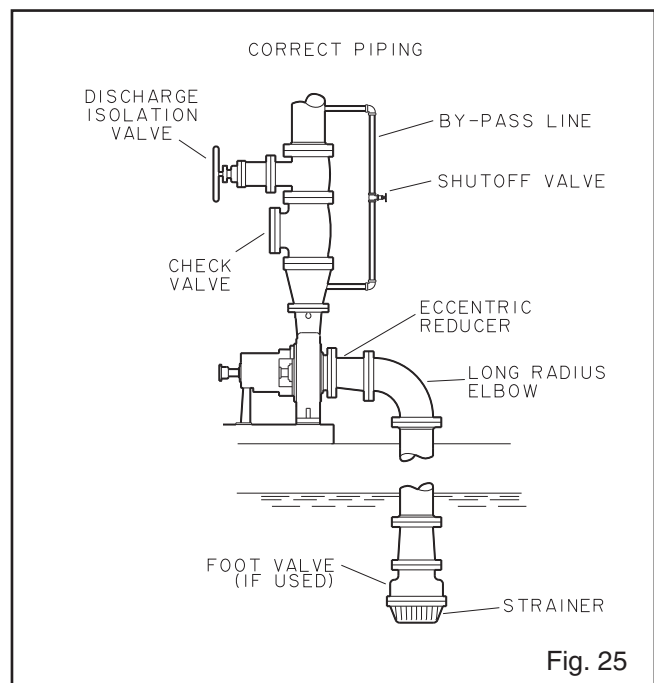

Fig. 25

- Piping should be level or slope gradually downward from the source of supply.
- No portion of the piping should extend below pump suction flange.
- The size of entrance from supply should be one or two sizes larger than the suction pipe.
- The suction pipe must be adequately submerged below the liquid surface to prevent vortices and air entrainment at the supply.

## DISCHARGE PIPING

1. Isolation and check valves should be installed in discharge line. Locate the check valve between isolation valve and pump, this will permit inspection of the check valve. The isolation valve is required for priming, regulation of flow, and for inspection and maintenance of pump. The check valve prevents pump or seal damage due to reverse flow through the pump when the driver is turned off.
2. Increasesers, if used, should be placed between pump and check valves.
3. Cushioning devices should be used to protect the pump from surges and water hammer if quick-closing valves are installed in system.

## FINAL PIPING CHECK

### **After connecting the piping to pump:**

1. Rotate shaft several times by hand to be sure that there is no binding and all parts are free.
2. Check alignment, per the alignment procedure outlined previously to determine absence of pipe strain. If pipe strain exists, correct piping.

# OPERATION

<b>PREPARATION FOR START-UP</b> . . . . .	<b>37</b>
Checking Rotation. . . . .	37
Check Impeller Clearance. . . . .	37
Couple Pump and Driver . . . . .	38
Lubricating Bearings . . . . .	39
Shaft Sealing . . . . .	39
Priming Pump . . . . .	42
<b>STARTING PUMP</b> . . . . .	<b>44</b>
<b>OPERATION</b> . . . . .	<b>44</b>
General Considerations . . . . .	44
Operating at Reduced Capacity. . . . .	44
Operating Under Freezing Conditions. . . . .	44
<b>SHUTDOWN</b> . . . . .	<b>45</b>
<b>FINAL ALIGNMENT</b> . . . . .	<b>45</b>

## PREPARATION FOR START-UP



*When installing in a potentially explosive environment, please ensure that the motor is properly certified.*



*The impeller clearance setting procedure must be followed. Improperly setting the clearance or not following any of the proper procedures can result in sparks, unexpected heat generation and equipment damage.*

### CHECKING ROTATION



#### CAUTION

*Serious damage may result if pump is run in the wrong rotation.*

1. Lock out power to driver.



#### WARNING

*Lock out driver power to prevent accidental start-up and physical injury.*

2. Make sure coupling hubs are securely fastened to the shafts and the coupling spacer has been removed.

**NOTE:** *Pump is shipped with coupling spacer removed.*

3. Unlock driver power.
4. Make sure everyone is clear. Jog driver just long enough to determine direction of rotation. Rotation must correspond to arrow on bearing housing.
5. Lock out power to driver.

### CHECK IMPELLER CLEARANCE

Prior to operating the pump, impeller clearances must be checked. This check will help ensure that the pump turns freely and that it operates at optimal efficiency for good equipment life and low energy consumption. See *Section 4, Table 3* for details.

The maximum impeller setting should not be set more than .005 inch (0.13mm) above values in *Table 3* or significant performance degradation will result.

Also, for pumpage temperatures above 200° F (93° C) the cold (ambient) setting must be increased per *Table 3*. This is necessary to prevent the impeller from contacting the casing due to differential expansion from the higher operating temperatures. See *Section 5, Preventive Maintenance*, for impeller adjustment procedure.

If using a cartridge mechanical seal, the centering clips must be installed and set screws loosened prior to setting impeller clearance.

 **CAUTION**  
*Failure to do so could result in sparks, heat generation, and mechanical seal damage.*

Once proper impeller setting is achieved, tighten the set screws in the seal locking ring and remove the centering clips prior to starting the pump.

## COUPLE PUMP AND DRIVER

  **WARNING**  
*Lock out driver power to prevent accidental rotation and physical injury.*

 *The coupling used in an ATEX classified environment must be properly certified.*

1. Install and lubricate coupling per manufacturer's instructions.

 *Service temperature in an ATEX classified environment is limited by Table 1 in the SAFETY section.*

**Table 3**  
**Impeller Clearances**

Cold Temperature Clearances for Various Service Temperatures, inches (mm)

Service Temperature	3196 and HT3196						LF3196	
	STX		MTX/LTX		XLTX/X17		STX MTX/LTX	
	inches	mm	inches	mm	inches	mm	inches	mm
-20 to 150°F (-29 to 66°C)	0.005	0.13	0.008	0.20	0.015	0.38	0.015	0.38
Up to 175°F (79°C)	0.005	0.13	0.008	0.20	0.015	0.38	0.015	0.38
Up to 200°F (93°C)	0.005	0.13	0.008	0.20	0.015	0.38	0.015	0.38
Up to 250°F (121°C)	0.006	0.16	0.009	0.23	0.016	0.41	0.016	0.41
Up to 300°F (149°C)	0.007	0.19	0.010	0.26	0.017	0.44	0.017	0.44
Up to 350°F (177°C)	0.009	0.22	0.012	0.29	0.019	0.47	0.019	0.47
Up to 400°F (204°C)	0.010	0.25	0.013	0.32	0.020	0.50	0.020	0.50
Up to 450°F (232°C)	0.011	0.28	0.014	0.35	0.021	0.53	0.021	0.53
Up to 500°F (260°C)	0.012	0.30	0.015	0.38	0.022	0.56	0.022	0.56
Up to 550°F (288°C)	0.013	0.33	0.016	0.41	0.023	0.59	0.023	0.59
Up to 600°F (316°C)	0.014	0.36	0.017	0.44	0.024	0.62	0.024	0.62
Up to 650°F (343°C)	0.016	0.39	0.019	0.47	0.026	0.65	0.026	0.65
Up to 700°F (371°C)	0.017	0.42	0.020	0.50	0.027	0.68	0.027	0.68

**Table 3, cont'd**  
**Impeller Clearances**

Cold Temperature Clearances for Various Service Temperatures, inches (mm)

Service Temperature	Cold Temperature Clearances for Various Service Temperatures, inches (mm)										
	CV 3196 <sup>1</sup>			3796		NM 3196				3198	
	STX	MTX/LTX	XLTX	STX	MTX/LTX	STX		MTX/LTX		STX MTX/LTX	
-20 to 150°F (-29 to 66°C)	0.06	1.52		0.015	0.38	0.005	0.13	0.008	0.20	0.015	0.38
Up to 175°F (79°C)	0.06	1.52		0.015	0.38	0.005	0.13	0.008	0.20	0.020	0.51
Up to 200°F (93°C)	0.06	1.52		0.015	0.38	0.005	0.13	0.008	0.20	0.024	0.61
Up to 250°F (121°C)	0.06	1.52		0.016	0.41					0.032	0.81
Up to 300°F (149°C)	0.06	1.52		0.017	0.44					0.040	1.02
Up to 350°F (177°C)	0.06	1.52		0.019	0.47						
Up to 400°F (204°C)	0.06	1.52		0.020	0.50						
Up to 450°F (232°C)				0.021	0.53						
Up to 500°F (260°C)				0.022	0.56						
Up to 550°F (288°C)											
Up to 600°F (316°C)											
Up to 650°F (343°C)											
Up to 700°F (371°C)											

Out of pump temperature range =

<sup>1</sup> Clearance is set from the back of the impeller to the stuffing box cover / seal chamber / backplate.  
 Footnote #1: CV3196 impeller clearance is set off seal chamber face.



2. Install coupling guard (Fig. 26). Refer to Coupling Guard Installation and Disassembly Section *Appendix II*.



**The coupling guard used in an ATEX classified environment must be constructed from a non-sparking material.**



### WARNING

**Never operate a pump without coupling guard properly installed. Refer to Appendix II for coupling guard installation instructions. Personal injury will occur if pump is run without coupling guard.**

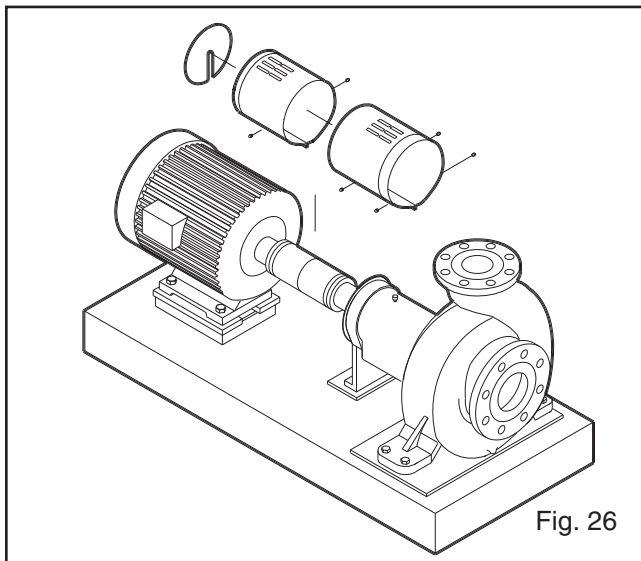

Fig. 26

## LUBRICATING BEARINGS



**Bearings must be lubricated properly in order to prevent excess heat generation, sparks and premature failure.**



### CAUTION

**Pumps are shipped without oil.**

**Oil Lubrication:** Fill bearing frame with oil, through filler connection (located on top of bearing frame refer to Fig. 34), until oil level reaches the middle of the sight-glass. A high quality turbine type oil with rust and oxidation inhibitors should be used. See *Table 5* for recommendations.

**Pure Oil Mist Lubrication:** Oil mist is an optional feature for the ANSI family pumps. Follow oil mist generator manufacturer's instructions. The inlet connections are located on the top of the bearing frame, connection points are covered under lubrication. (Refer to *Appendix I* on converting lubrication.)

**Grease Lubrication:** Pumps are shipped **with** grease. See *Table 6* for grease requirements.

**Greased For Life Bearings:** These bearings are filled with grease and sealed by the bearing manufacturer.

If the pump is put into operation after a prolonged shut down, flush out the bearings and bearing frame with a light oil to remove contaminants. During flushing, rotate the shaft slowly by hand. Finally, flush the bearing housing with proper lubricating oil to insure oil quality after cleaning.

See *Preventive Maintenance* section for lubrication recommendations.



### CAUTION

**Operation of the unit without proper lubrication will cause bearing failure, and pump seizure.**

4

## SHAFT SEALING



**The mechanical seal used in an ATEX classified environment must be properly certified.**

### Cartridge Mechanical Seals:

1. Slide the cartridge seal onto the shaft or sleeve until it contacts the inboard labyrinth oil seal.
2. Assemble the seal chamber per the instructions in *Section 6 - Disassembly & Reassembly*.
3. Slide the cartridge seal into the seal chamber and secure using the four studs and nuts.
4. Continue the pump reassembly per the instructions in *Section 6 - Disassembly & Reassembly*.
5. Set the impeller clearance per the instructions in *Section 4 - Operation*.
6. Tighten the set screws in the seal locking ring to secure the seal to the shaft.
7. Remove the centering clips from the seal.

### Conventional Inside Component Mechanical Seal:

1. Assemble the seal chamber per the instructions in *Section 6 - Disassembly & Reassembly*.
2. Apply bluing to the shaft/sleeve at the face of the seal chamber.
3. Continue the complete reassembly of the pump, less the mechanical seal.
4. Set the impeller clearance per the instructions in *Section 4 - Operation*.

5. Scribe a line on the blued shaft/sleeve at the face of the seal chamber.
6. Remove the casing, impeller, and seal chamber per the instructions in *Section 6 - Disassembly & Reassembly*.
7. Slide the gland (with the stationary seat and gland gasket installed) onto the shaft until it contacts the inboard labyrinth oil seal.
8. Install the mechanical seal rotary unit per the manufacturer's instructions using the scribed line and the seal reference dimension.
9. Reassemble the seal chamber per the instructions in *Section 6 - Disassembly & Reassembly*.
10. Slide the gland on the seal chamber studs and secure with the gland nuts. Be sure to tighten the nuts evenly such that the gland is seated on the seal chamber pilot and is perpendicular to the shaft.
11. Complete the reassembly of the pump per the instructions in *Section 6 - Disassembly & Reassembly*.

**Conventional Outside Component Mechanical Seal:**

1. Assemble the seal chamber per the instructions in *Section 6 - Disassembly & Reassembly*.
2. Apply bluing to the shaft/sleeve at the face of the seal chamber.
3. Continue the complete reassembly of the pump, less the mechanical seal.
4. Set the impeller clearance per the instructions in *Section 4 - Operation*.
5. Scribe a line on the blued shaft/sleeve at the face of the seal chamber.
6. Remove the casing, impeller, and seal chamber per the instructions in *Section 6 - Disassembly & Reassembly*.
7. Install the mechanical seal rotary unit per the manufacturer's instructions using the scribed line and the seal reference dimension. Be sure to secure the rotary unit in place using the set screws in the locking ring.
8. Install the gland (with the stationary seat and gland gaskets installed) on the seal chamber.
9. Reassemble the seal chamber per the instructions in *Section 6 - Disassembly & Reassembly*.
10. Complete the reassembly of the pump per the

instructions in *Section 6 - Disassembly & Reassembly*.



**The mechanical seal must always be properly flushed. Failure to do so will result in excess heat generation and seal failure.**

**Connection of Sealing Liquid:** For satisfactory operation, there must be a liquid film between seal faces to lubricate them. Refer to the seal manufacturer's drawing for the location of the taps. Some methods which may be used to flush/cool the seal are:

- a. *Product Flushing* - In this arrangement, the pumpage is piped from the casing (and cooled in an external heat exchanger, when required) then injected into seal gland.
- b. *External Flush* - A clean, cool compatible liquid is injected from an outside source directly into the seal gland. The flushing liquid must be at a pressure of 5-15 psi (0.35-1.01 kg/cm<sup>2</sup>) greater than the seal chamber pressure. Injection rate should be ½-2 GPM (2-8 LPM).
- c. Other methods may be used which make use of multiple gland connections and/or seal chamber connections. Refer to the documentation supplied with the pump, mechanical seal reference drawing, and piping diagrams.



**Packed stuffing boxes are not allowed in an ATEX classified environment.**

**Packed Stuffing Box Option:** Models 3196, CV 3196, HT 3196, LF 3196, and 3796 pumps are shipped without packing, lantern ring or split gland installed. These are included with the box of fittings shipped with the pump and must be installed before start-up.

**Installation of Packing:**

1. Carefully clean stuffing box bore.
2. Twist the packing just enough to get it around the shaft (Figs. 27, 28).
3. Insert packing, staggering the joints in each ring by 90°.
4. The stuffing box arrangement in order of installation is: 2 packing rings, lantern ring (two-piece), then 3 packing rings.



**CAUTION**

**Follow instructions to ensure the lantern ring is located at the flushing connection (Fig. 29). Otherwise, no flush will be obtained.**

5. Install the gland halves and evenly hand tighten the nuts.

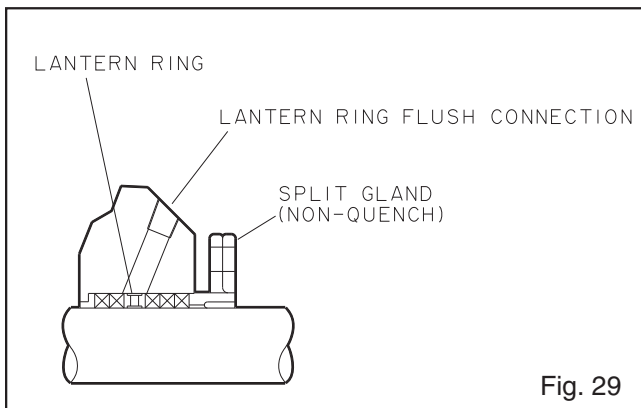
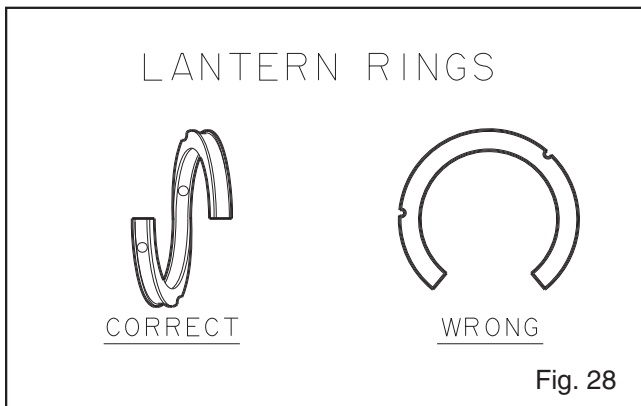
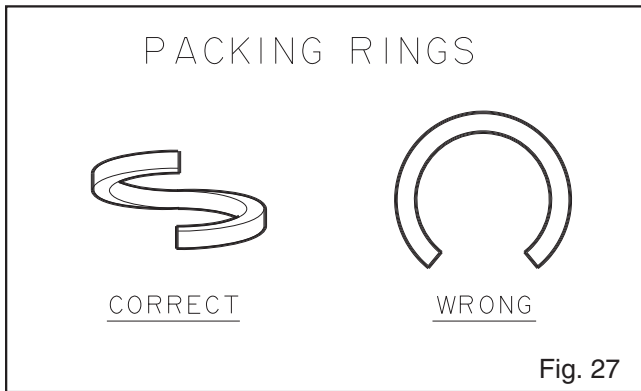

**Connection of Sealing Liquid:** If the stuffing box pressure is above atmospheric pressure and the pumpage is clean, normal gland leakage of 40-60 drops per minute is usually sufficient to lubricate and cool the packing and sealing liquid is not required.

**NOTE: Otherwise, a product flush can be used if a clean pumpage exists.**

An external sealing liquid is required when:

1. Abrasive particles in the pumpage could score shaft sleeve.

2. Stuffing box pressure is below atmospheric pressure due to the pump running with a suction lift, or when the suction source is under a vacuum. Under these conditions, packing will not be cooled and lubricated and air will be drawn into pump.

If an outside source of clean compatible liquid is required, the pressure should be 15 psi (1.0 kg/cm<sup>2</sup>) above the suction pressure. The piping should be connected to the lantern ring connection with a 40-60 drops-per-minute leak rate.

**NOTE: Most packing requires lubrication. Failure to lubricate packing may shorten the life of the packing and pump.**



**Dynamic seals are not allowed in an ATEX classified environment.**

**Dynamic Seal Option:** The 3196, CV 3196, and LF 3196 dynamic seal consists of two seals: a repeller that prevents leakage during pump operation and a secondary seal that prevents leakage when the unit is not operating. The repeller acts as a pump to prevent liquid from entering the stuffing box during pump operation. The repeller does not require a flush except for services which allow a build-up of solids on the repeller. A flush connection can be provided for this purpose. A drain connection can also be supplied to drain the repeller chamber if a danger of freezing exists.

**Secondary Seals:** The secondary seal prevents leakage during pump shut down. This seal is either graphite packing or an elastomeric face or lip seal.

1. **Graphite Packing** - This packing will provide adequate life running dry but will provide longer performance if it is lubricated with either clean water or grease. When clean water is used, remember that the repeller reduces both the quantity and pressure of seal water required. If the suction head is less than the repeller capability, the stuffing box pressure is the same as atmospheric. Seal water pressure must be high enough to overcome static head when the pump is not operating to keep pumpage out of the packing. Flow must be sufficient to cool the packing. If grease is used as the lubricant, spring-loaded grease lubricators should be used to maintain a constant supply.
2. **Elastomeric Face or Lip Seal** - The elastomeric face seal consists of an elastomer rotary fitted to the shaft, and a ceramic stationary seat fitted in the gland. To set the seal, remove the gland nuts and slide the gland back on the sleeve. Pull the

rotary back on the sleeve until it is about 1 inch beyond the stuffing box face. Push the gland back onto the studs, pushing the rotary back along the sleeve. Tighten the gland nuts. This ensures contact, no other adjustments are needed. The lip seal is pressed into the gland and no adjustment is required. Both seals are designed to run dry, so no flush is required.

**NOTE: HT 3196, NM 3196, 3796, and 3198 are not available with dynamic seal options.**



**Pumps that are not self-priming must be fully primed at all times during operation. The only model line in this manual that is self-priming is the 3796.**

## PRIMING PUMP

(3196, CV 3196, HT3196, LF 3196, 3198, and NM 3196)

Never start the pump until it has been properly primed. Several different methods of priming can be used, depending upon type of installation and service involved.

### Suction Supply Above Pump

1. Slowly open the suction valve (Fig. 30).
2. Open air vents on the suction and discharge piping until water flows out.
3. Close the vent valves.

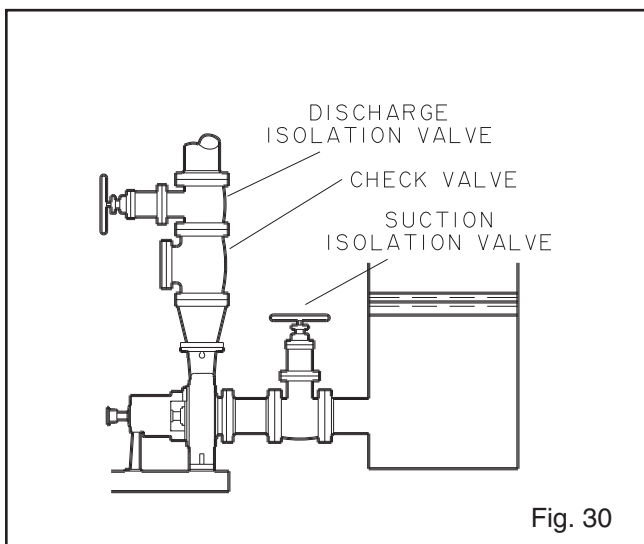

### Suction Supply Below Pump (except 3796)

A foot valve and outside source of liquid may be used to prime the pump. Outside source of liquid can come from a priming pump, pressurized discharge line, or other outside supply (Fig. 31 and 32).

**NOTE: Model 3796 is a self-priming pump and does not require the use of a foot valve in the suction line. Refer to the pump's performance curve to determine the time required for priming.**

1. Close discharge valve and open air vents in casing.
2. Open valve in outside supply line until only liquid escapes from vent valves.
3. Close the vent valves and then the outside supply line.

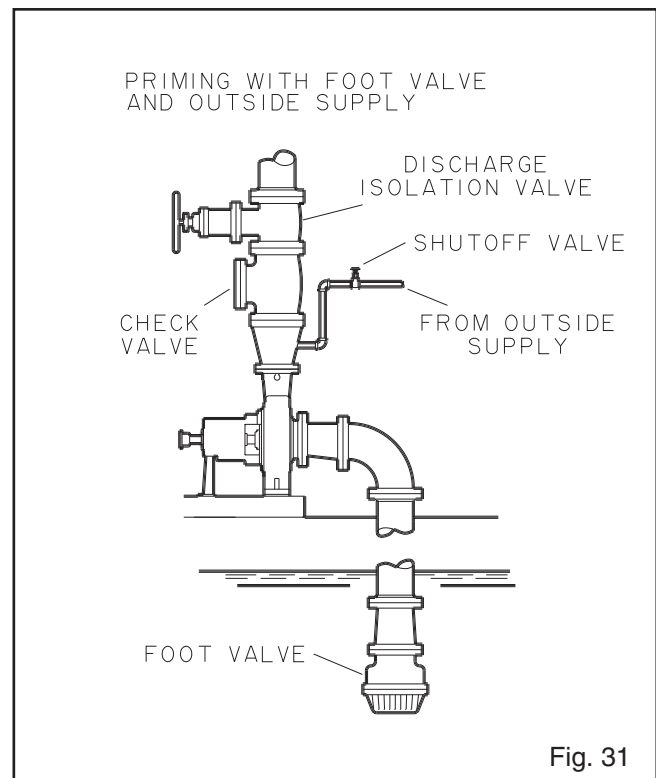

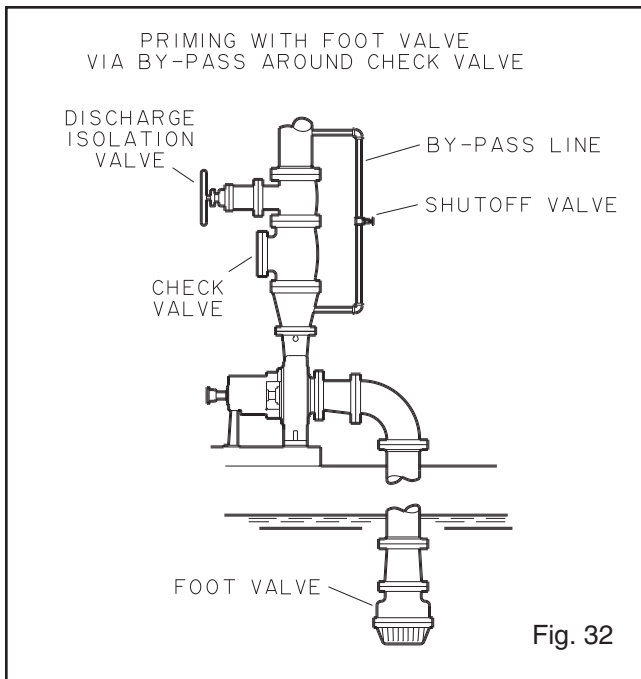

### Suction Supply Below Pump - 3796

**NOTE:** The 3796 is a self-priming pump and does not require manual priming prior to start-up (except for the initial charge). However, in a pressurized system, the pump requires an air vent or a permanent bypass line in the discharge piping to vent the evacuated air.

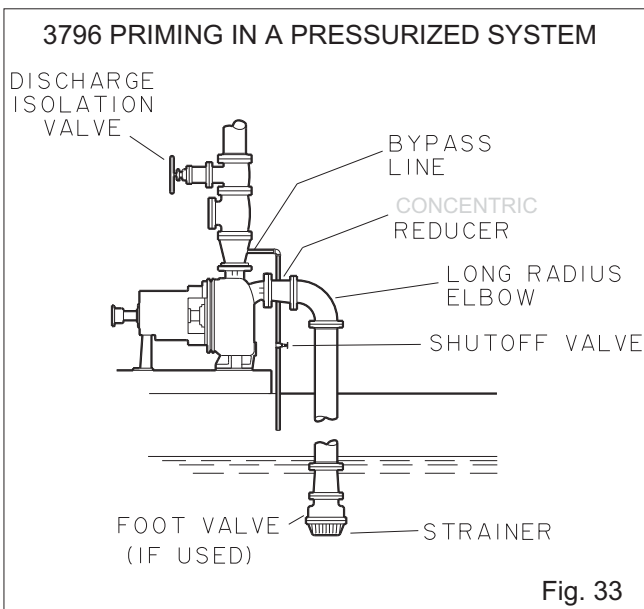

### Other Methods of Priming:

1. Priming by Ejector.
2. Priming by Automatic Priming Pump.



## CAUTION



### START-UP PRECAUTIONS

1. All equipment and personal safety related devices and controls must be installed and operating properly.
2. To prevent premature pump failure at initial start-up due to dirt or debris in the pipe system, ensure the system has been adequately cleaned and flushed.
3. Variable speed drivers should be brought to rated speed as quickly as possible.
4. Variable speed drivers should not be adjusted or checked for speed governor or overspeed trip settings while coupled to the pump at initial start-up. If settings have not been verified, uncouple the unit and refer to driver manufacturer's instructions for assistance.
5. Running a new or rebuilt pump at slow speeds may not provide enough flow to adequately flush and cool the stuffing box bushing's close running surfaces.
6. Pumpage temperatures in excess of 200° F (93° C) will require warm-up of pump prior to operation. Circulate a small amount of pumpage through the pump until the casing temperature is within 100° F (38° C) of the pumpage temperature and evenly heated.

**NOTE:** Warm-up rate should not exceed 1.4° C (2.5° F) per minute.

## STARTING PUMP

1. Make sure suction valve and any recirculation or cooling lines are open.
2. Fully close or partially open discharge valve as dictated by system conditions.
3. Start Driver.
4. Slowly open discharge valve until the desired flow is obtained.



### CAUTION

*Immediately observe pressure gauges. If discharge pressure is not quickly attained - stop driver, reprime and attempt to restart.*



### CAUTION

*Observe pump for vibration levels, bearing temperature and excessive noise. If normal levels are exceeded, shut down and resolve.*

## OPERATION

### GENERAL CONSIDERATIONS



### CAUTION

*Always vary capacity with regulating valve in the discharge line. NEVER throttle flow from the suction side.*



### CAUTION

*Driver may overload if the pumpage specific gravity (density) is greater than originally assumed, or the rated flow rate is exceeded.*



### CAUTION

*Always operate the pump at or near the rated conditions to prevent damage resulting from cavitation or recirculation.*

### OPERATING AT REDUCED CAPACITY



### WARNING

*DO NOT operate pump below minimum rated flows or with suction and/or discharge valve closed. These conditions may create an explosive hazard due to vaporization of pumpage and can quickly lead to pump failure and physical injury.*



### CAUTION

*Damage occurs from:*

1. Increased vibration levels - Affects bearings, stuffing box or seal chamber, and mechanical seal.
2. Increased radial loads - Stresses on shaft and bearings.
3. Heat build up - Vaporization causing rotating parts to score or seize.
4. Cavitation - Damage to internal surfaces of pump.

### OPERATING UNDER FREEZING CONDITIONS

Exposure to freezing conditions, while pump is idle, could cause liquid to freeze and damage the pump. Liquid inside pump should be drained. Liquid inside cooling coils, if supplied, should also be drained.

## SHUTDOWN

1. Slowly close discharge valve.
2. Shut down and lock driver to prevent accidental rotation.



### WARNING

*When handling hazardous and/or toxic fluids, proper personal protective equipment should be worn. If pump is being drained, precautions must be taken to prevent physical injury. Pumpage must be handled and disposed of in conformance with applicable environmental regulations.*

## FINAL ALIGNMENT



***Alignment procedures must be followed to prevent unintended contact of rotating parts. Follow coupling manufacturer's coupling installation and operation procedures.***

1. Run the unit under actual operating conditions for a sufficient length of time to bring the pump and driver and associated system up to operating temperature.
2. Remove coupling guard. Refer to coupling guard installation and disassembly instructions in *Appendix II*.
3. Check alignment while unit is still hot per alignment procedure in the *Installation* Section.
4. Reinstall coupling guard. Refer to coupling guard instruction in *Appendix II*.





# PREVENTIVE MAINTENANCE

<b>GENERAL COMMENTS</b>	<b>47</b>
<b>MAINTENANCE SCHEDULE</b>	<b>47</b>
<b>MAINTENANCE OF BEARINGS</b>	<b>48</b>
Oil Lubricated Bearings	48
Grease Lubricated Bearings	48
<b>MAINTENANCE OF SHAFT SEALS</b>	<b>50</b>
Mechanical Seals	50
Packed Stuffing Box	50
Dynamic Seal	50
<b>IMPELLER CLEARANCE SETTING</b>	<b>51</b>
Dial Indicator Method	51
Feeler Gauge Method	52
<b>TROUBLESHOOTING</b>	<b>54</b>

## GENERAL COMMENTS

A routine maintenance program can extend the life of your pump. Well maintained equipment will last longer and require fewer repairs. You should keep maintenance records, this will help pinpoint potential causes of problems.

5



*The preventive maintenance section must be adhered to in order to keep the applicable ATEX classification of the equipment. Failure to follow these procedures will void the ATEX classification for the equipment.*

## MAINTENANCE SCHEDULE

### ROUTINE MAINTENANCE

- Bearing lubrication
- Seal monitoring
- Vibration analysis
- Discharge pressure
- Temperature monitoring

### ROUTINE INSPECTIONS

- Check level and condition of oil through sight glass on bearing frame.
- Check for unusual noise, vibration and bearing temperatures.
- Inspect pump and piping for leaks.

- Check seal chamber/stuffing box leakage.
  - Mechanical Seal: Should be no leakage.
  - Packing: Excessive leakage requires adjustment or possible packing replacement. Refer to *Section 4 - Operation* for packing gland adjustment.

### 3 MONTH INSPECTIONS

- Check the foundation and the hold-down bolts for tightness.
- If the pump has been left idle, check the packing. Replace if required.
- Oil should be changed at least every 3 months (2000 hours) or more often if there are any adverse atmospheric conditions or other conditions which might contaminate or break down the oil. If it is cloudy or contaminated as seen by inspection through the sight glass, it should be changed immediately.
- Check the shaft alignment. Realign if required.

## ANNUAL INSPECTIONS

- Check the pump capacity, pressure and power. If pump performance does not satisfy your process requirements, and the process requirements have not changed, the pump should be disassembled, inspected, and worn parts should be replaced. Otherwise, a system inspection should be done.

## INSPECTION INTERVALS

Inspection intervals should be shortened appropriately if the pumpage is abrasive and/or corrosive,



**or if the environment is classified as potentially explosive.**

# MAINTENANCE OF BEARINGS



**Throughout this section on bearing lubrication, different pumpage temperatures are listed. If the equipment is ATEX certified and the listed temperature exceeds the applicable value shown in Table 1 under SAFETY, then that temperature is not valid. When this situation occurs please consult with your ITT Goulds representative.**

## OIL LUBRICATED BEARINGS



### WARNING

**Pumps are shipped without oil. Oil lubricated bearings must be lubricated at the job site.**

Remove fill plug (113A) and add oil until level is at the center of the sight glass (319). Replace fill plug (Fig. 34) (See Table 4).

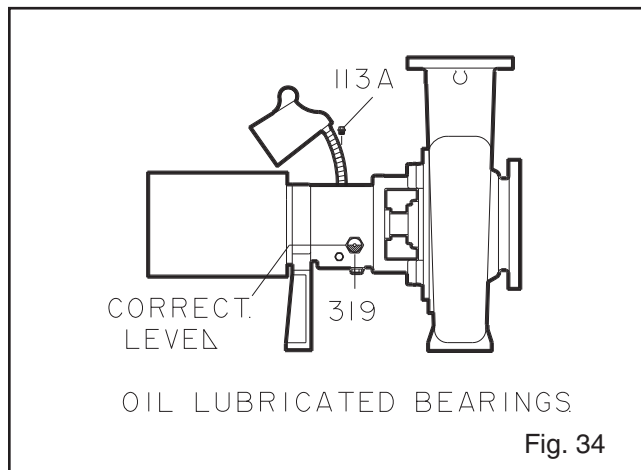

Change the oil after 200 hours for new bearings, thereafter every 2000 operating hours or 3 months (whichever comes first).

**Table 4  
Oil Volumes**

Frame	Qts.	Oz.	ml
STX	0.5	16	400
MTX	1.3	42	1250
LTX	1.5	48	1400
XLT-X and X17	3	96	3000

A high quality turbine oil with rust and oxidation inhibitors should be used. For the majority of operational conditions, bearing temperatures will run between 120°F (50°C) and 180°F (82°C). In this range, an oil of ISO viscosity grade 68 at 100°F (40°C) is recommended. If bearing temperatures exceed 180°F (82°C), use ISO viscosity grade 100 with Bearing Frame cooling or Finned Tube oil cooler. The Finned Tube oil cooler is standard with the model HT 3196 and optional for all other models (See Table 5). For higher operating temperatures, pumpage above 350°F (177°C), synthetic lubrication is recommended.

Table 5 Lubricating Oil Requirements		
	Pumpage temperature below 350°F (177°C)	Pumpage temperature above 350°F (177°C)
ISO Grade	VG 68	VG 100
Approx. SSU at 100°F (38°C)	300	470
DIN 51517	C68	C100
Kinem. viscosity at 100°F (40°C) mm <sup>2</sup> /sec	68	100

**Some acceptable lubricants are:**

Chevron	GTS Oil 68
Exxon	Teresstic 68 or NUTO H68
Mobil	Mobil DTE 26 300 SSU @ 100°F (38°C)
Philips	Mangus Oil 315
Shell	Tellus Oil 68
Sunoco	Sunvis 968
Royal Purple	SYNFILM ISO VG 68 Synthetic Lube

### GREASE LUBRICATED BEARINGS

Grease lubricated bearings are pre-lubricated at the factory. Most pumps have Sunoco 2EP grease. High temperature units (pumpage temperature greater than 350° F) use Mobil SCH32. Regrease bearings every 2000 operating hours or 3 months.

**Regrease Procedure:**

**NOTE: When regreasing, there is danger of impurities entering the bearing housing. The grease container, the greasing device, and fittings must be clean.**

1. Wipe dirt from grease fittings.
2. Remove 2 grease relief plugs (113) from bottom of frame.
3. Fill both grease cavities through fittings with recommended grease until fresh grease comes out of the relief holes. Reinstall grease relief plugs (113).
4. Ensure frame seals are seated in bearing housing and, if not, press in place with drains located at the bottom.

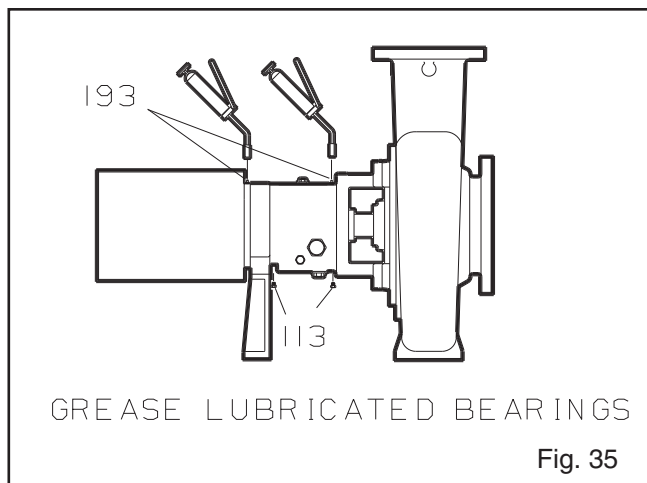

**NOTE: The bearing temperature usually rises after regreasing due to an excess supply of grease. Temperatures will return to normal after pump has run and purged the excess from the bearings, usually two to four hours.**

For most operating conditions a lithium based mineral oil grease of NLGI consistency No. 2 is recommended. This grease is acceptable for bearing temperatures of 5°F to 230°F (-15°C to 110°C). Bearing temperatures are generally about 20°F (18°C) higher than bearing housing outer surface temperature.

**5**

Table 6 Lubricating Grease Requirements		
	Pumpage temperature below 350°F (177°C)	Pumpage temperature above 350°F (177°C)
NGLI consistency	2	3
Mobil	Mobilux EP2	SCH32
Exxon	Unirex N2	Unirex N3
Sunoco	Multipurpose 2EP	
SKF	LGMT 2	LGMT 3

**CAUTION**  
**Never mix greases of different consistency (NGLI 1 or 3 with NGLI 2) or different thickener. For example never mix a lithium base grease with a polyurea base grease.**

Pumpage temperatures above 350°F (177°C) should be lubricated by a high temperature grease. Mineral oil greases should have oxidation stabilizers and a consistency of NGLI 3.

**NOTE: If it is necessary to change grease type or consistency, the bearings must be removed and the old grease removed.**

# MAINTENANCE OF SHAFT SEALS

 **The mechanical seal used in an ATEX classified environment must be properly certified.**

## MECHANICAL SEALS

When mechanical seals are furnished, a manufacturer's reference drawing is supplied with the data package. This drawing should be kept for future use when performing maintenance and adjusting the seal. The seal drawing will also specify required flush liquid and attachment points. The seal and all flush piping must be checked and installed as needed prior to starting the pump.

The life of a mechanical seal depends on various factors such as cleanliness of the liquid handled and its lubricating properties. Due to the diversity of operating conditions it is, however, not possible to give definite indications as to its life.

## **WARNING**

**Never operate the pump without liquid supplied to mechanical seal. Running a mechanical seal dry, even for a few seconds, can cause seal damage and must be avoided. Physical injury can occur if mechanical seal fails.**

## PACKED STUFFING BOX (3196, CV 3196, HT 3196, LF 3196, 3796)

 **Packed stuffing boxes are not allowed in an ATEX classified environment.**

Packing operation can be inspected without shutting down or disassembling the pump. During normal operation the packing should leak approximately one drop per minute. If the drip rate is higher or lower than one drop per minute then an adjustment of the gland may be required. To slow down the leakage rate, the two gland bolts should be tightened evenly one-quarter ( $\frac{1}{4}$ ) turn each until the desired leakage rate is obtained. NEVER over-tighten packing to the point where less than one drop per minute is observed. Overtightening can cause excessive wear and power consumption during operation. If the packing cannot be tightened to obtain less than two drops per minute, then the packing may need to be replaced and the packing installation procedures under **Operation** should be followed.

## **CAUTION**

**Never attempt to replace packing until the driver is properly locked out and the coupling spacer is removed.**

## DYNAMIC SEAL (3196, CV 3196, LF 3196)

 **Dynamic seals are not allowed in an ATEX classified environment.**

### Dynamic Seal Components

**Repeller** - The dynamic repeller effectively prevents leakage of pumpage through the stuffing box when the pump is *operating* under published acceptable conditions. Dynamic seal parts do not wear substantially to affect operation unless the service is particularly abrasive or corrosive. Refer to *Disassembly and Reassembly* Section for maintenance, disassembly, and repair.

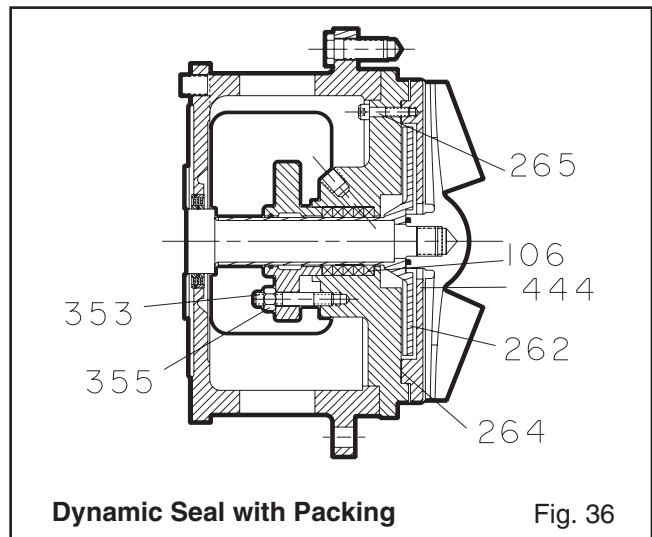

**Static Seal** - A static seal is used to prevent leakage when the pump is *shut down*. This is either a lip seal, elastomeric face seal, or graphite packing. The lip and elastomeric face seal require no maintenance other than replacement when leakage becomes excessive. The packing should be installed as stuffing box packing. It is a special type designed to run dry, so it does not require an external flush.

**NOTE:** HT 3196, NM 3196, 3796, and 3198 are not available with dynamic seal option.

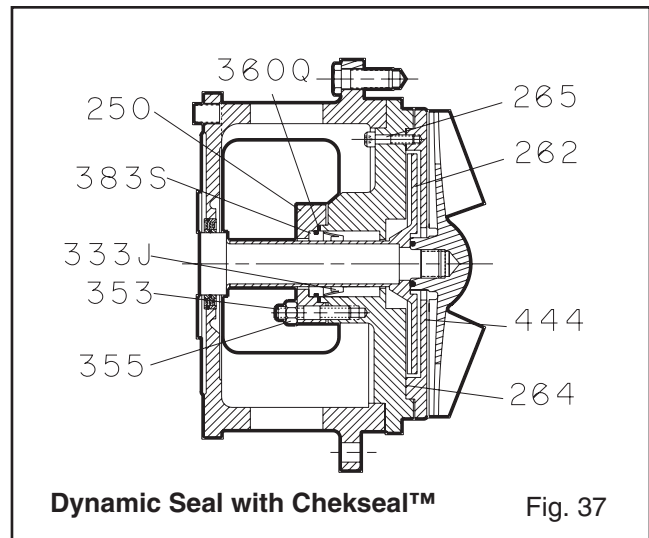

Dynamic Seal with Chekseal™ Fig. 37

## IMPELLER CLEARANCE SETTING

 **The impeller clearance setting procedure must be followed. Improperly setting the clearance or not following any of the proper procedures can result in sparks, unexpected heat generation and equipment damage.**



### WARNING

**Lock out driver power to prevent accidental startup and physical injury.**

A change in pump performance may be noted over time by a drop in head or flow or an increase in power required. Performance can usually be renewed by adjusting the impeller clearance. Two techniques are given to set the impeller clearance, the dial indicator method and the feeler gauge method.

### DIAL INDICATOR METHOD (all but CV)

1. Remove coupling guard. Refer to coupling guard instructions *Appendix II*.
2. Remove coupling.
3. Set indicator so that button contacts either the shaft end or against face of coupling (Fig. 38).
4. Loosen jam nuts (423) on jack bolts (370D) and back bolts out about two turns.
5. Tighten each locking bolt (370C) evenly, drawing the bearing housing (134A) towards the bearing frame (228) until impeller contacts the casing. Turn the shaft to ensure contact is made.

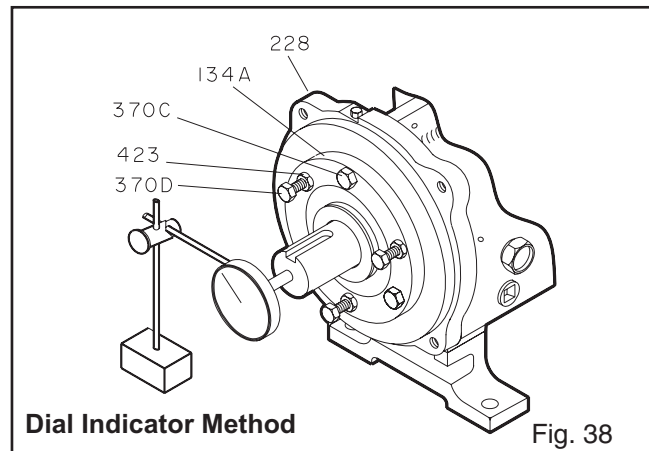

6. Set indicator to zero and back locking bolt (370C) out about one turn.
7. Thread jack bolts (370D) in until they evenly contact the bearing frame. Tighten the jack bolts evenly (about one flat at a time) backing the bearing housing (134A) away from the bearing frame until the indicator shows the proper clearance per *Table 3*.
8. Evenly tighten locking bolts (370C), then jack bolts (370D) keeping indicator reading at proper setting.
9. Check shaft for free turning.
10. Replace coupling guard.

## DIAL INDICATOR METHOD (CV 3196)

1. Remove coupling guard. Refer to coupling guard instructions *Appendix II*.
2. Remove coupling.
3. Set indicator so that button contacts either the shaft end or against the face of coupling (Fig. 38).
4. Loosen each locking bolt (370C) several turns.
5. Loosen jam nuts (423) on jack bolts (370D) and turn bolts in several turns until impeller contacts the stuffing box cover or seal chamber. Turn shaft to ensure contact is made.
6. Set dial indicator at zero.
7. Back off the jacking bolts (370D) several turns and tighten the locking bolts (370C) to move the impeller away from the stuffing box cover or seal chamber until the dial indicator shows that a .060" clearance has been obtained.
8. Turn in the jacking bolts (370D) and tighten the jam nuts (423) evenly.
9. Check shaft for free turning.
10. Replace coupling.
11. Replace coupling guard.

## FEELER GAUGE METHOD (all but CV)

1. Remove coupling guard. Refer to coupling guard instructions in *Appendix II*.
2. Loosen jam nuts (423) on jack bolts (371A) and back bolts out about two turns (Fig. 39).
3. Tighten locking bolts (370C) evenly, drawing bearing housing (134A) towards frame (228) until impeller contacts the casing. Turn shaft to ensure contact is made.
4. Using a feeler gauge, set the gap between the three locking bolts (370C) and bearing housing (134A) per impeller clearances in *Table 3*.
5. Evenly back out bearing housing (134A) using the three jack bolts (370D) until it contacts the locking bolts (370C). Evenly tighten jam nuts (423B).
6. Check shaft for free turning.
7. Replace coupling guard.

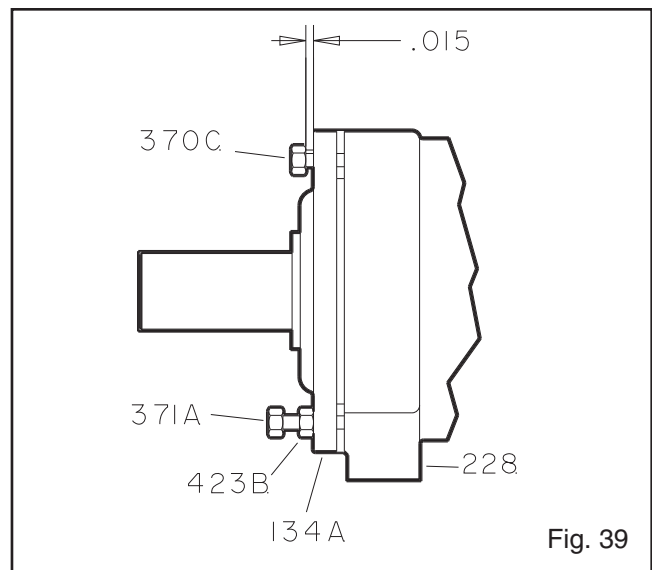

## FEELER GAUGE METHOD (CV)

1. Remove coupling guard. Refer to coupling guard instruction in *Appendix II*.
2. Remove coupling.
3. Loosen each locking bolt (370C) several turns.
4. Loosen jam nuts (423) on jack bolts and turn bolts in several turns until impeller contacts the stuffing box cover or seal chamber. Turn shaft to ensure contact is made.
5. Measure the gap between the bearing housing and the bearing frame with feeler gauges. Reduce this measurement by .060" and place the resultant feeler gauges between the bearing housing and the bearing frame as shown in Fig. 39.
6. Back off the jacking bolts (370D) several turns and tighten the locking bolts (370C) to move the impeller away from the stuffing box cover or seal chamber until the bearing housing snugs up the feeler gauges between the bearing housing and the bearing frame.
7. Turn in the jacking bolts (370D) and tighten the jam nuts (423) evenly.
8. Check shaft for free turning.
9. Replace coupling.
10. Replace coupling guard.

Table 3								
Impeller Clearances								
Cold Temperature Clearances for Various Service Temperatures, inches (mm)								
Service Temperature	3196 and HT3196						LF3196	
	STX		MTX/LTX		XLTX/X17		STX MTX/LTX	
	inches	mm	inches	mm	inches	mm	inches	mm
-20 to 150°F (-29 to 66°C)	0.005	0.13	0.008	0.20	0.015	0.38	0.015	0.38
Up to 175°F (79°C)	0.005	0.13	0.008	0.20	0.015	0.38	0.015	0.38
Up to 200°F (93°C)	0.005	0.13	0.008	0.20	0.015	0.38	0.015	0.38
Up to 250°F (121°C)	0.006	0.16	0.009	0.23	0.016	0.41	0.016	0.41
Up to 300°F (149°C)	0.007	0.19	0.010	0.26	0.017	0.44	0.017	0.44
Up to 350°F (177°C)	0.009	0.22	0.012	0.29	0.019	0.47	0.019	0.47
Up to 400°F (204°C)	0.010	0.25	0.013	0.32	0.020	0.50	0.020	0.50
Up to 450°F (232°C)	0.011	0.28	0.014	0.35	0.021	0.53	0.021	0.53
Up to 500°F (260°C)	0.012	0.30	0.015	0.38	0.022	0.56	0.022	0.56
Up to 550°F (288°C)	0.013	0.33	0.016	0.41	0.023	0.59	0.023	0.59
Up to 600°F (316°C)	0.014	0.36	0.017	0.44	0.024	0.62	0.024	0.62
Up to 650°F (343°C)	0.016	0.39	0.019	0.47	0.026	0.65	0.026	0.65
Up to 700°F (371°C)	0.017	0.42	0.020	0.50	0.027	0.68	0.027	0.68

Table 3, cont'd											
Impeller Clearances											
Cold Temperature Clearances for Various Service Temperatures, inches (mm)											
Service Temperature	CV 3196 <sup>1</sup>			3796		NM 3196				3198	
	STX	MTX/LTX	XLTX	STX	MTX/LTX	STX		MTX/LTX		STX MTX/LTX	
-20 to 150°F (-29 to 66°C)	0.06	1.52		0.015	0.38	0.005	0.13	0.008	0.20	0.015	0.38
Up to 175°F (79°C)	0.06	1.52		0.015	0.38	0.005	0.13	0.008	0.20	0.020	0.51
Up to 200°F (93°C)	0.06	1.52		0.015	0.38	0.005	0.13	0.008	0.20	0.024	0.61
Up to 250°F (121°C)	0.06	1.52		0.016	0.41					0.032	0.81
Up to 300°F (149°C)	0.06	1.52		0.017	0.44					0.040	1.02
Up to 350°F (177°C)	0.06	1.52		0.019	0.47						
Up to 400°F (204°C)	0.06	1.52		0.020	0.50						
Up to 450°F (232°C)				0.021	0.53						
Up to 500°F (260°C)				0.022	0.56						
Up to 550°F (288°C)											
Up to 600°F (316°C)											
Up to 650°F (343°C)											
Up to 700°F (371°C)											

5

Out of pump temperature range =                     

<sup>1</sup> Clearance is set from the back of the impeller to the stuffing box cover / seal chamber / backplate.

# TROUBLESHOOTING

Problem	Probable Cause	Remedy
<b>No liquid delivered.</b>	Pump not primed.	Reprime pump, check that pump and suction line are full of liquid.
	Suction line clogged.	Remove obstructions.
	Impeller clogged with foreign material.	Back flush pump to clean impeller.
	Wrong direction of rotation.	Change rotation to concur with direction indicated by arrow on bearing housing or pump casing.
	Foot valve or suction pipe opening not submerged enough.	Consult factory for proper depth. Use baffle to eliminate vortices.
	Suction lift too high.	Shorten suction pipe.
<b>No liquid delivered (3796)</b>	Vent line not connected.	Pipe in vent line to expel air.
<b>Pump not producing rated flow or head.</b>	Air leak thru gasket.	Replace gasket.
	Air leak thru stuffing box	Replace or readjust packing/mechanical seal.
	Impeller partly clogged.	Back flush pump to clean impeller.
	Excessive impeller-to-casing clearance.	Adjust impeller clearance.
	Insufficient suction head.	Ensure that suction line shutoff valve is fully open and line is unobstructed.
	Worn or broken impeller.	Inspect and replace if necessary.
<b>Pump starts then stops pumping.</b>	Improperly primed pump.	Reprime pump.
	Air or vapor pockets in suction line.	Rearrange piping to eliminate air pockets.
	Air leak in suction line.	Repair (plug) leak.
<b>Bearings run hot.</b>	Improper alignment.	Realign pump and driver.
	Improper lubrication.	Check lubricant for suitability and level.
	Lube cooling.	Check cooling system.
<b>Pump is noisy or vibrates.</b>	Improper pump/driver alignment.	Align shafts.
	Partly clogged impeller causing imbalance.	Back-flush pump to clean impeller.
	Broken or bent impeller or shaft.	Replace as required.
	Foundation not rigid.	Tighten hold down bolts of pump and motor or adjust stilts.
	Worn bearings.	Replace.
	Suction or discharge piping not anchored or properly supported.	Anchor per Hydraulic Institute Standards Manual recommendations
	Pump is cavitating.	Locate and correct system problem.
<b>Excessive leakage from stuffing box.</b>	Packing gland improperly adjusted.	Tighten gland nuts.
	Stuffing box improperly packed.	Check packing and repack box.
	Worn mechanical seal parts.	Replace worn parts.
	Overheating mechanical seal.	Check lubrication and cooling lines.
	Shaft sleeve scored.	Remachine or replace as required.
<b>Motor requires excessive power.</b>	Head lower than rating. Pumps too much liquid.	Consult factory. Install throttle valve, trim impeller diameter.
	Liquid heavier than expected.	Check specific gravity and viscosity.
	Stuffing box packing too tight.	Readjust packing. Replace if worn.
	Rotating parts bind.	Check internal wearing parts for proper clearances.



# DISASSEMBLY & REASSEMBLY

REQUIRED TOOLS . . . . .	55
DISASSEMBLY . . . . .	55
INSPECTIONS . . . . .	68
REASSEMBLY . . . . .	74

## REQUIRED TOOLS

- Wrenches
- Screwdriver
- Lifting Sling
- Rubber Mallet
- Induction Bearing Heater
- Bearing Puller
- Brass Drift Punch
- Snap-Ring Pliers
- Torque Wrench with Sockets
- Allen Wrenches
- Dial Indicator
- Micrometer
- Cleaning Agents
- Feeler Gauges
- Hydraulic Press
- Leveling Blocks

## DISASSEMBLY



### WARNING

*Pump components can be heavy. Proper methods of lifting must be employed to avoid physical injury and/or equipment damage. Steel toed shoes must be worn at all times.*



### WARNING

*The pump may handle hazardous and/or toxic fluids. Proper personal protective equipment should be worn. Precautions must be taken to prevent physical injury. Pumpage must be handled and disposed of in conformance with applicable environmental regulations.*

**NOTE:** Before disassembling the pump for overhaul, ensure all replacement parts are available.



### WARNING

*Lock out power supply to driver motor to prevent accidental startup and physical injury.*

1. Shut off all valves controlling flow to and from pump.



### WARNING

*Operator must be aware of pumpage and safety precautions to prevent physical injury.*

2. Drain liquid from piping, flush pump if necessary.



*If pump is a Model NM3196 or a 3198 there may be a risk of static electric discharge from plastic parts that are not properly grounded. If pumped fluid is non-conductive, pump should be drained and flushed with a conductive fluid under conditions that will not allow for a spark to be released to the atmosphere.*



## WARNING

**Allow all system and pump components to cool before handling them to prevent physical injury.**

3. Disconnect all auxiliary piping and tubing.
4. Remove coupling guard. Refer to Coupling Guard Installation and Disassembly Section in *Appendix II*.
5. Disconnect Coupling.

**NOTE: Refer to Appendix V for C-Face adapter disassembly instructions, if required.**

6. Remove coupling guard pump endplate.
7. If oil lubricated, drain oil from bearing frame by removing bearing frame drain plug (408A). Replace plug after oil is drained. Remove oil reservoir, if equipped (Fig. 40).

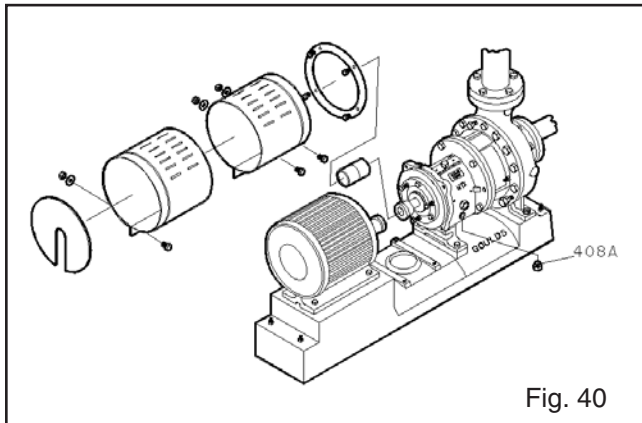

**NOTE: Oil analysis should be part of a preventive maintenance program and is helpful to determine cause of a failure. Save oil in a clean container for inspection.**

8. *All, except with C-Face adapter:* Place sling from hoist through frame adapter (108) or frame (228A) for STX (Fig. 41).

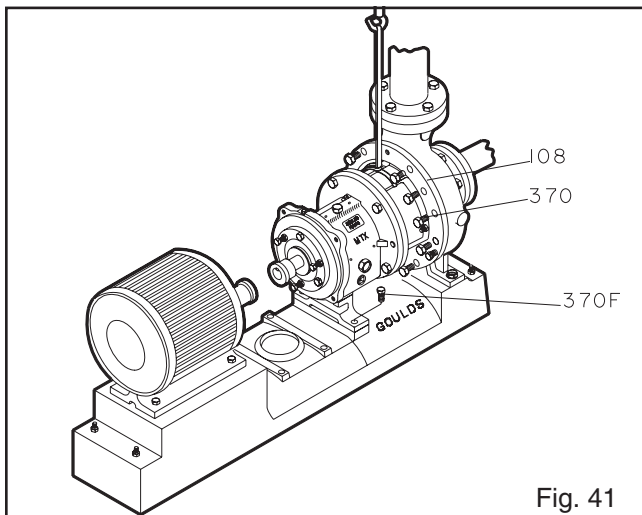

*C-Face adapter:* Place one sling from hoist through frame adapter (108) or frame (228A) for STX and a second sling from hoist through the C-Face adapter (Fig. 42).

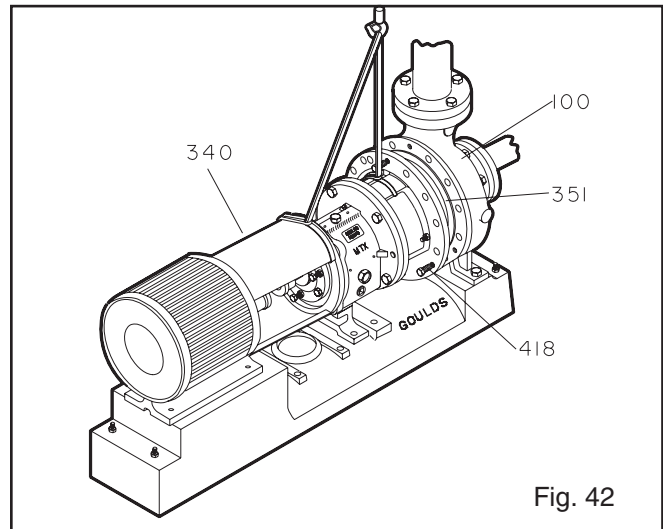

9. Remove bearing frame foot hold down bolts.
  10. Remove casing bolts (370).
- WARNING**
- Never apply heat to remove parts. Use of heat may cause an explosion due to trapped fluid, resulting in severe physical injury and property damage.**
11. Remove back pull-out assembly from casing (100). Tighten jack screws (418) evenly to remove back pull-out assembly (Fig. 43).

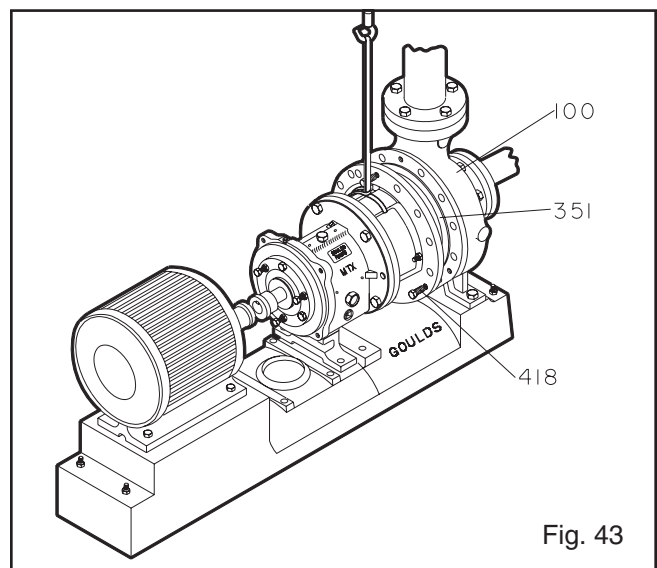

**NOTE: Penetrating oil can be used if adapter to casing joint is excessively corroded.**

**NOTE: Remove and then mark shims from under frame foot. Save for reassembly.**



## WARNING

**Never remove the back pull-out assembly unassisted, physical injury can occur.**

- Remove casing gasket (351) and discard. (Replace with new gasket during reassembly.)
- Remove jack screws (418).

**NOTE: Casing gasket (351) may partially adhere to casing due to binders and adhesives in the gasket material. Clean all gasket surfaces.**

- Move back pull-out assembly to clean workbench.
- Support frame adapter (108) securely to workbench.
- Remove coupling hub (Fig. 44).

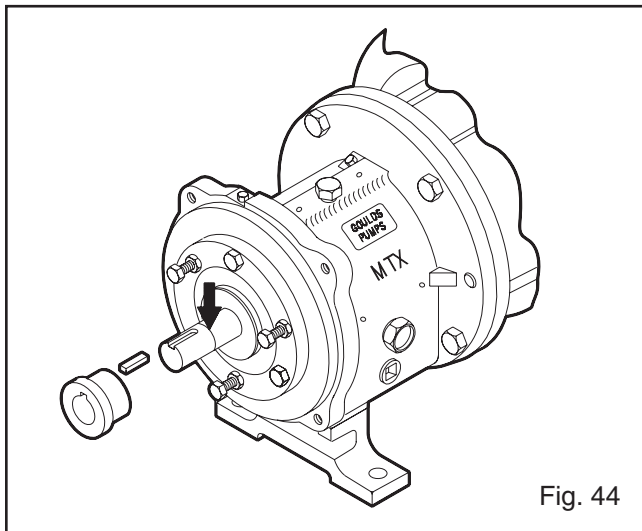

Fig. 44

**NOTE: Blue and scribe shaft for relocating coupling hub during reassembly.**

## REMOVAL OF IMPELLER



## WARNING

**Never apply heat to remove an impeller. The use of heat may cause an explosion due to trapped fluid, resulting in severe physical injury and property damage.**



## WARNING

**Wear heavy work gloves when handling impellers (101) as sharp edges may cause physical injury.**

### STX, MTX, & LTX

- Slide ITT Goulds shaft wrench (A05107A or A01676A) over the shaft (122) and key.

- Rotate the impeller clockwise (viewed from the impeller end of the shaft), raising the wrench off of the work surface.
- Quickly turn the impeller counterclockwise (viewed from the impeller end of the shaft), impacting the wrench handle on the workbench or a solid block until the impeller loosens (Fig. 45).

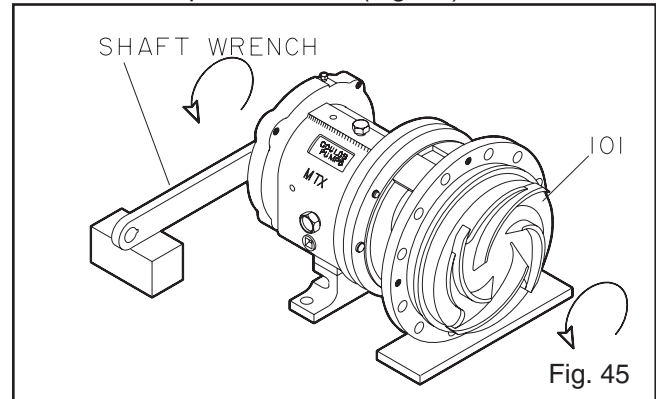

Fig. 45

- Remove impeller O-ring (412A) and discard (Fig. 46, 47, 48). Replace with a new o-ring during reassembly.

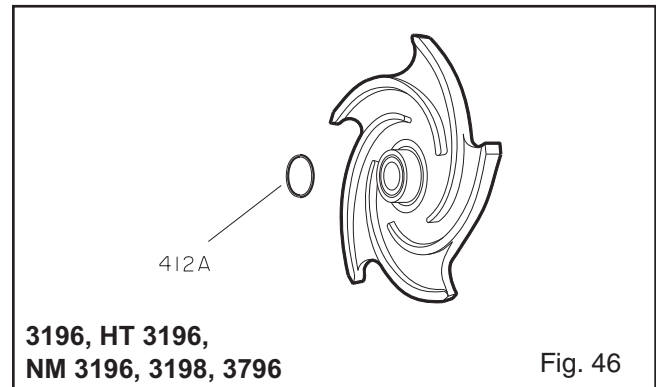

Fig. 46

3196, HT 3196,  
NM 3196, 3198, 3796

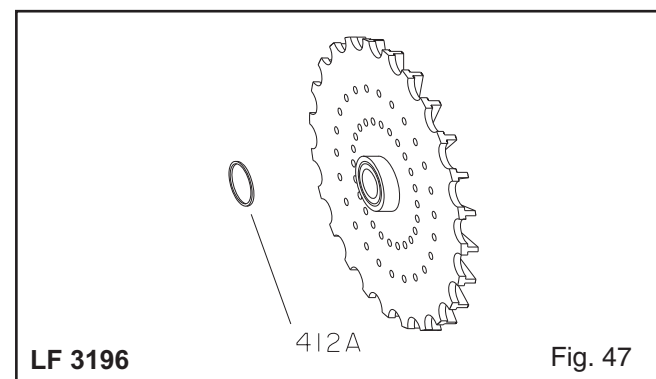
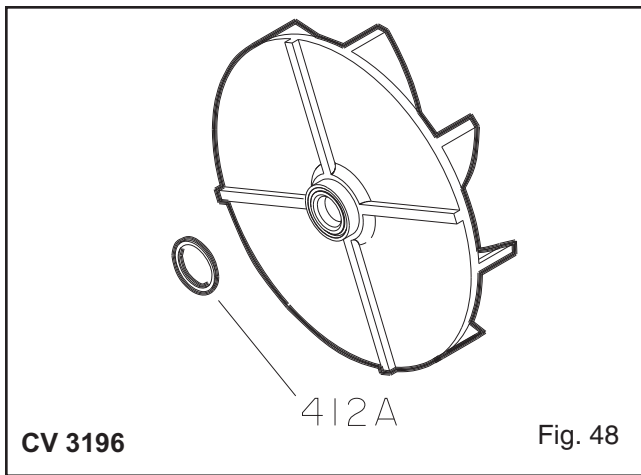

Fig. 47

LF 3196



6. If the impeller cannot be loosened after several attempts, place a socket wrench over the cast nut on the impeller hub and turn the impeller counterclockwise (viewed from the impeller end of the shaft). Be sure the impeller wrench is resting on the workbench or a solid block and the power end is secure on the work surface.
7. Remove impeller O-ring (412A) and discard (Fig. 46, 47, 48). Replace with a new o-ring during reassembly.

**NOTE:** It is recommended that the frame foot (241) be clamped to the workbench when using this method to remove the impeller.

**NOTE FOR ALL MODELS:** If the impeller cannot be removed by the previous methods, cut the shaft between the gland and the frame, remove the impeller, stuffing box cover, gland, sleeve and shaft end as a unit. Do not use heat.

### XLT-X & X17

1. Remove impeller plug (458Y) from the front of the impeller (101) and discard the Teflon® gasket (428D) (Fig. 49).

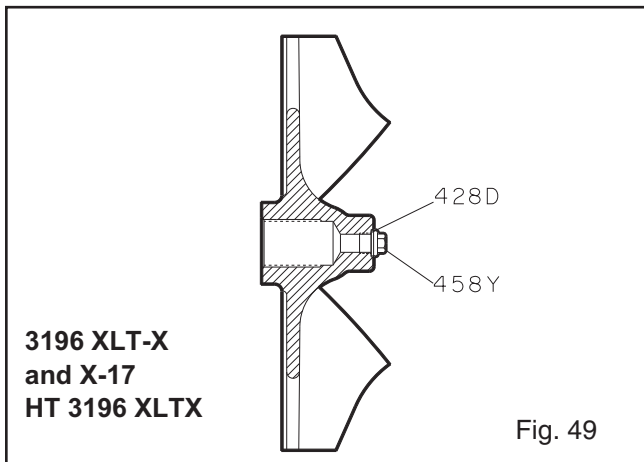

2. Spray penetrating oil through the plug hole into the cavity at the end of the shaft. Wait 15 minutes. Rotate the shaft several times while waiting to distribute the oil.
3. Slide ITT Goulds shaft wrench (A05107A) over the shaft (122) and key.
4. Rotate the impeller clockwise (viewed from the impeller end of the shaft), raising the wrench off of the work surface.
5. Quickly turn the impeller counterclockwise (viewed from the impeller end of the shaft), impacting the wrench handle on the workbench or a solid block until the impeller loosens (Fig. 45).

### REMOVAL OF SEAL CHAMBER COVER (MECHANICAL SEAL) - 3196, CV 3196, HT 3196, LF 3196, 3796

1. Remove gland stud nuts (355).
2. Remove seal chamber stud nuts (370H).
3. Remove seal chamber (184). (Fig. 50)

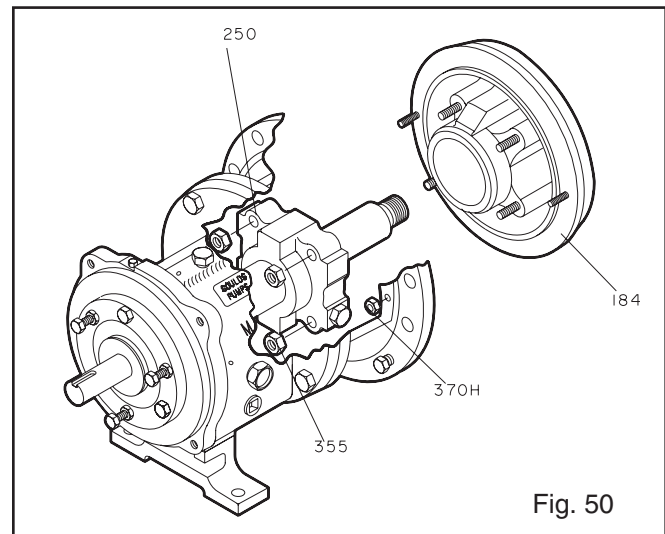

4. Remove shaft sleeve (126), if used.

**NOTE:** Mechanical seal is attached to sleeve (126). Rotary portion of seal needs to be removed from sleeve by loosening set screws and sliding it off the sleeve. Refer to mechanical seal instructions.

- Remove gland (250) with stationary seat and O-ring (360Q) (Fig. 51).

**NOTE:** Be careful not to damage the stationary portion of the mechanical seal. It is seated in the gland bore.

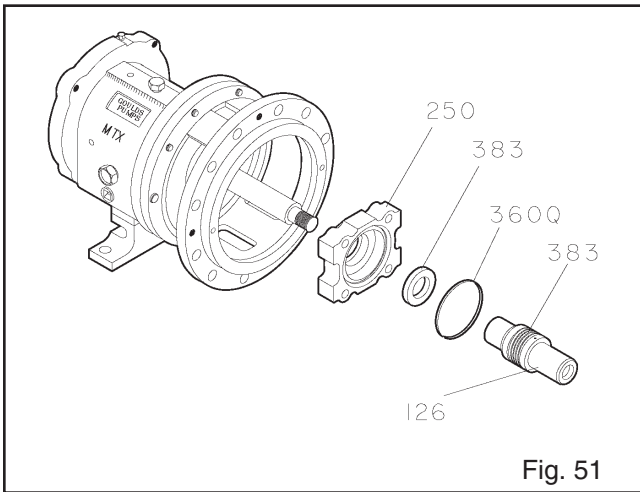

Fig. 51

### REMOVAL OF SEAL CHAMBER COVER AND/OR BACKPLATE - NM 3196 & 3198

- Remove the gland or seal chamber stud nuts (355).
- Remove the backplate and stud nuts (370H).
- Remove the backplate (184) (Fig. 52).

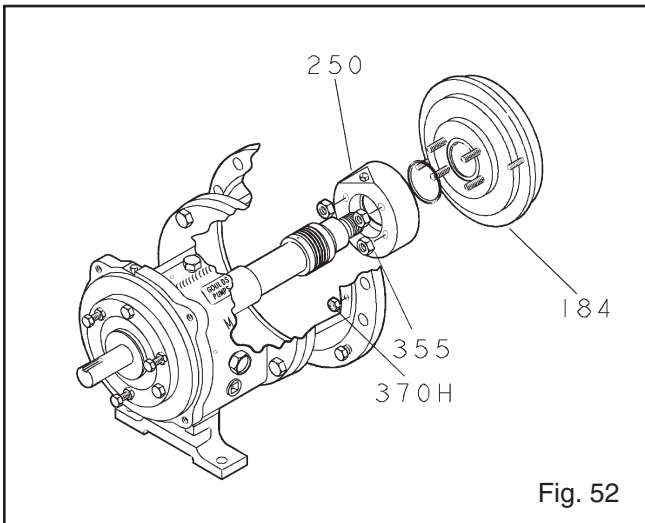

Fig. 52

- Remove the shaft sleeve (126).

**NOTE:** The mechanical seal is attached to the sleeve (126). The rotary portion of the seal needs to be removed from the sleeve by loosening the set screws and sliding off the sleeve. Refer to the mechanical seal instructions.

**NOTE:** The Teflon® sleeve on the 3198 must be cut off the shaft to be removed. First remove the mechanical seal from the sleeve. Now, the sleeve can be removed by slicing the sleeve lengthwise with a sharp knife.

- Remove the stationary seat and the gland or seal chamber with the gland gaskets (Figs. 53 & 54).

**NOTE:** Be careful not to damage the stationary portion of the mechanical seal. It is either clamped between the backplate and the gland or seated in the seal chamber bore.

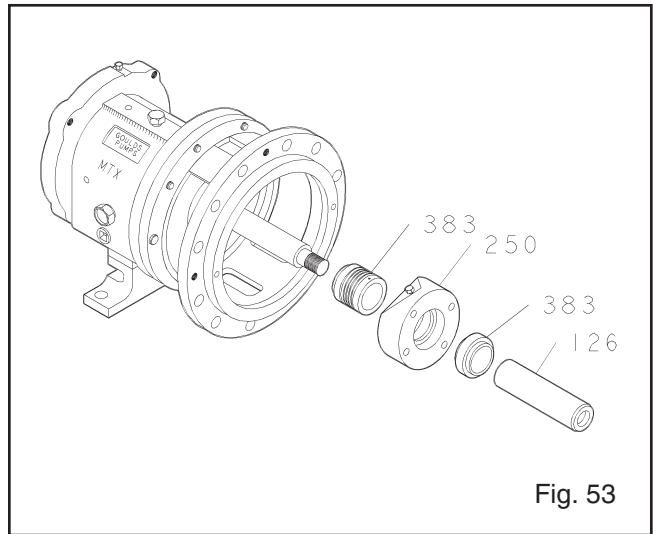
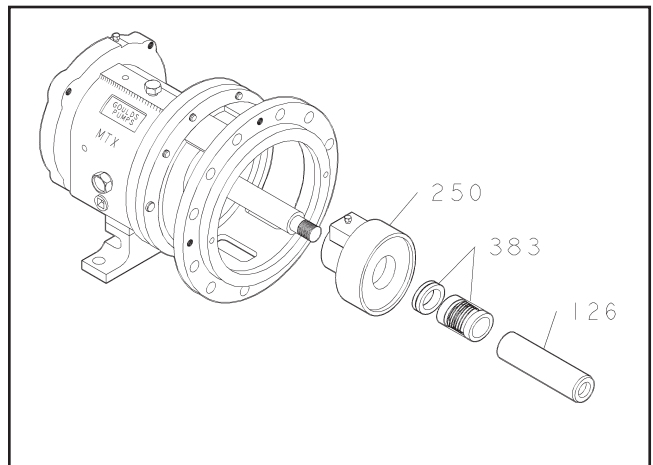

Fig. 53



### REMOVAL OF STUFFING BOX COVER (PACKED BOX) - 3196, CV 3196, HT 3196, LF 3196, & 3796

- Remove gland stud nuts (355), and gland (107).
- Remove stuffing box cover stud nuts (370H).

3. Remove stuffing box cover (184). (Fig. 55).

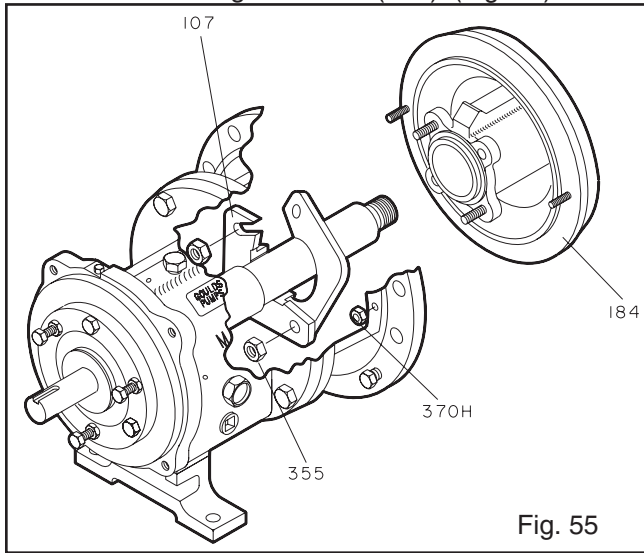

Fig. 55

4. Remove shaft sleeve (126) (Fig. 56).

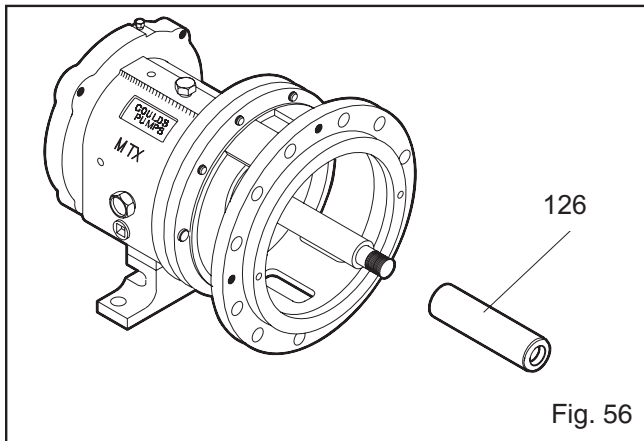

Fig. 56

5. Remove packing (106) and lantern ring (105) from stuffing box cover (184) (Fig. 57). No lantern ring is provided with self-lubricating graphite packing.

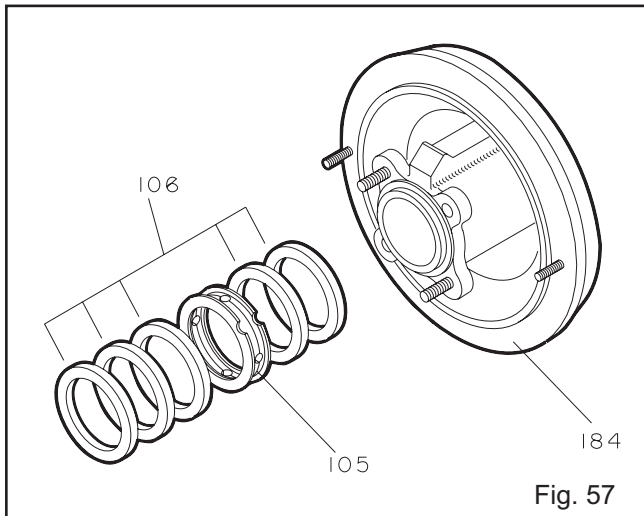

Fig. 57

## REMOVAL OF DYNAMIC SEAL - 3196, CV 3196, LF 3196

1. Remove stud nuts (370H).
2. Remove dynamic seal assembly (Fig. 58).

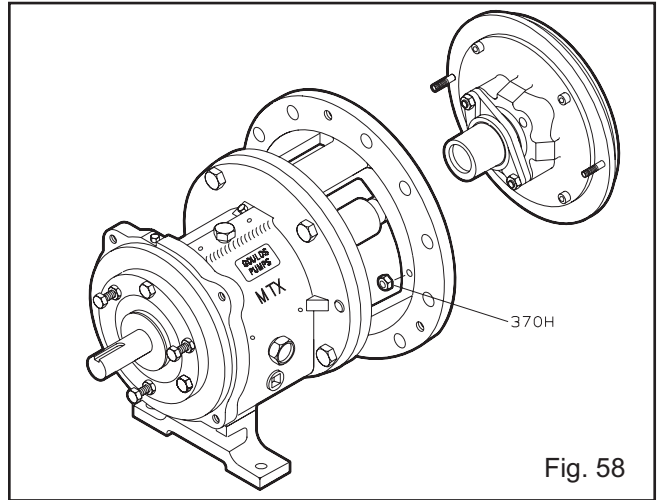

Fig. 58

3. Remove socket head cap screws (265) (Fig. 59).
4. Remove stuffing box cover (184) and gasket (264).
5. Remove repeller (262) from backplate (444).

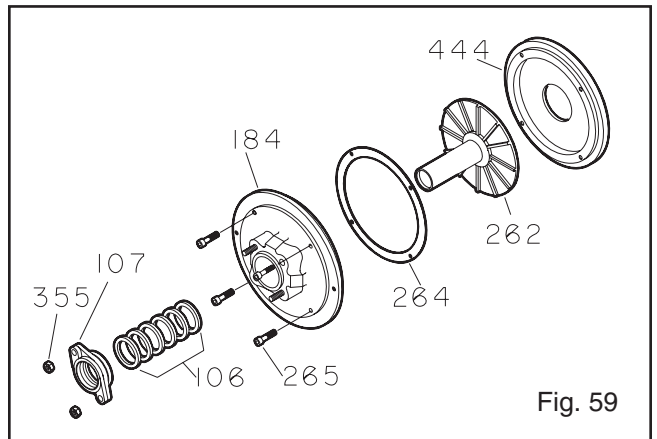

Fig. 59

## REMOVE FRAME ADAPTER - MTX, LTX, XLT-X, X17

1. Remove dowel pins (469B), and bolts (370B).
2. Remove frame adapter (108) (Fig. 60).
3. Remove and discard gasket (360D). Replace with new gasket during reassembly.

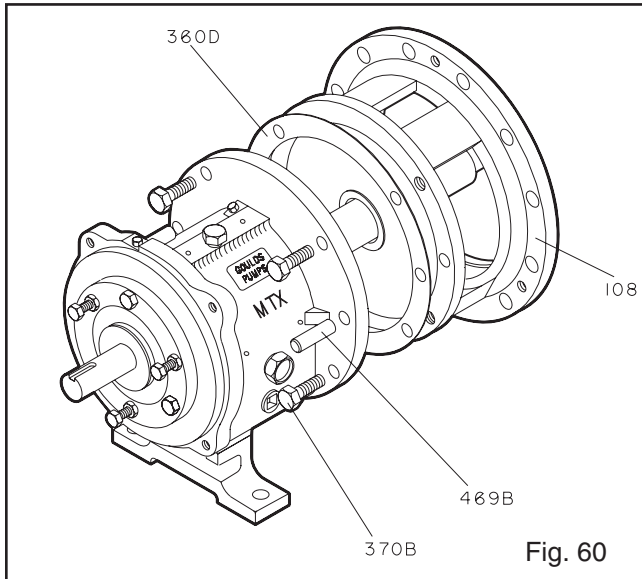

Fig. 60

**NOTE:** The 3198 frame adapter is not interchangeable with any other model's adapter.

## REMOVE INBOARD LABYRINTH OIL SEAL (333A)

1. It is an O-ring fit into the bearing frame (228A) for STX, frame adapter (108) for MTX, LTX, XLT-X and X17. Remove O-rings (497H), (497J) if necessary (Fig. 61).

**NOTE:** Labyrinth oil seal O-rings (497H, J) are part of 3196 maintenance kits or can be obtained separately.

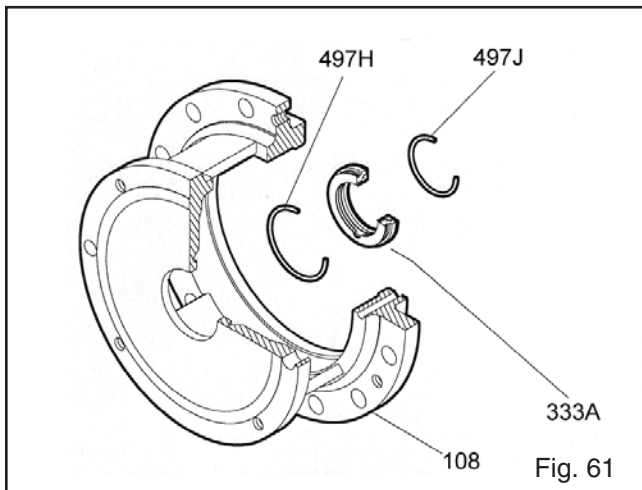

Fig. 61

## DISASSEMBLY OF POWER END - STX, MTX

1. Remove clamp screws (370C). Back off jam nuts (423). Tighten jack screws (370D) evenly, this will start bearing housing (134) out of bearing frame (228A) (Fig. 62).
2. Remove the shaft assembly from the bearing frame (228A).

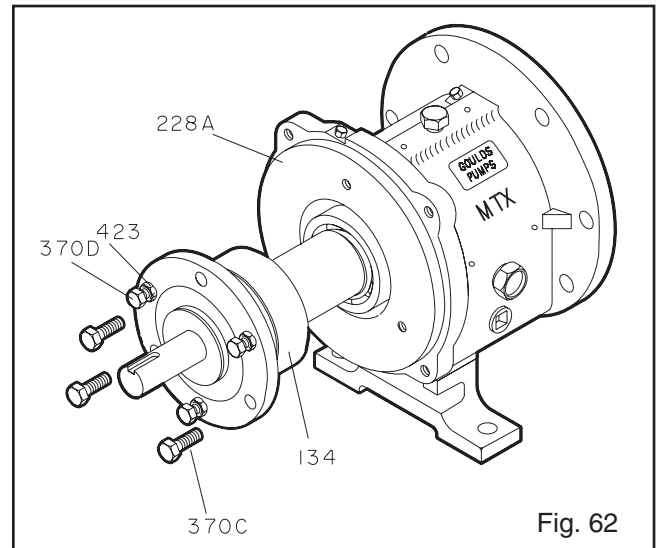

Fig. 62

3. Remove jack screws (370D) with nuts (423) (Fig. 63).
4. Remove bearing housing O-ring (496).
5. Remove outboard bearing retaining snap ring (361A).

**NOTE:** Snap ring cannot be removed from the shaft until bearings are removed.

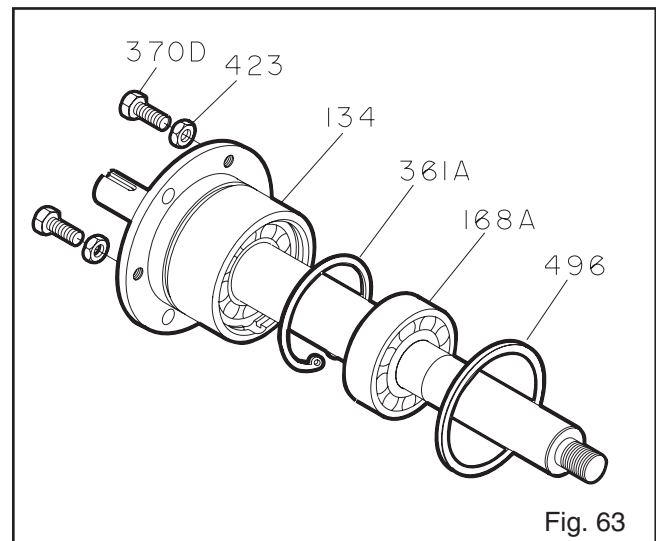
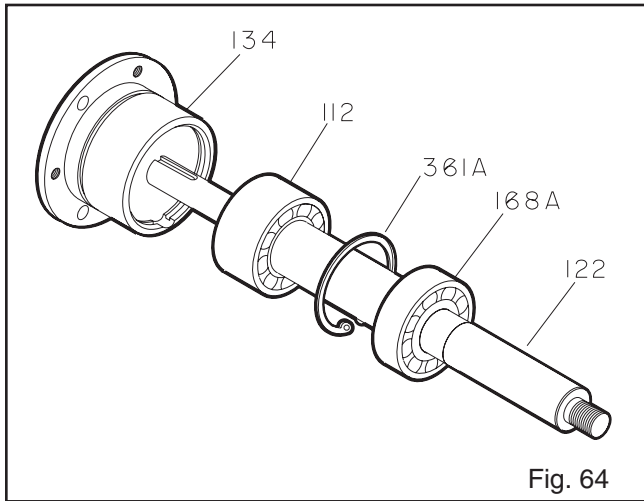

Fig. 63

6. Remove bearing housing (134) from shaft (122) with bearings (112A, 168A) (Fig. 64).



- Remove outboard labyrinth seal (332A) from bearing housing (134). Remove O-rings (497F), (497G) if necessary (Fig. 65).

**NOTE: Labyrinth oil seal O-rings (497F, G) are part of 3196 maintenance kits or can be obtained separately.**

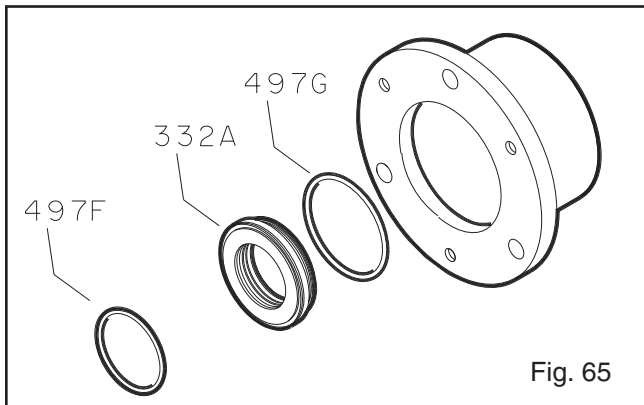

- Remove bearing locknut (136) and bearing lock washer (382) (Fig. 66).
- Remove inboard bearing (168A).
- Remove outboard bearing (112A).

**NOTE: When pressing bearings off shaft, use force on inner race only.**

**NOTE: Save bearings for inspection.**

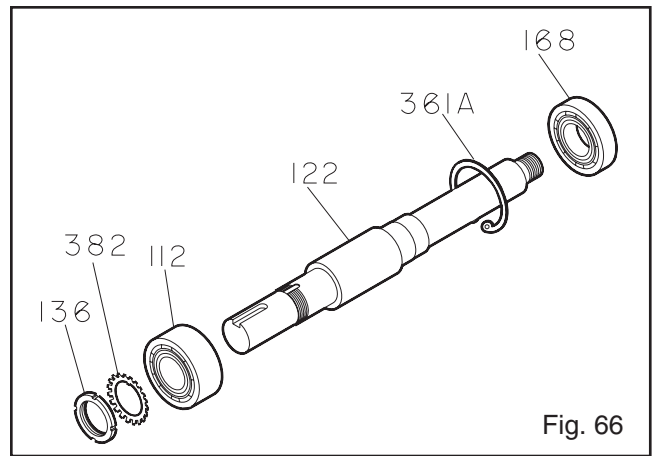

### DISASSEMBLY OF POWER END - LTX

- Remove clamp screws (370C). Back off jam nuts (423). Tighten jack screws (370D) evenly, this will start bearing housing (134) out of bearing frame (228A) (Fig. 67).
- Remove shaft assembly from bearing frame (228A).

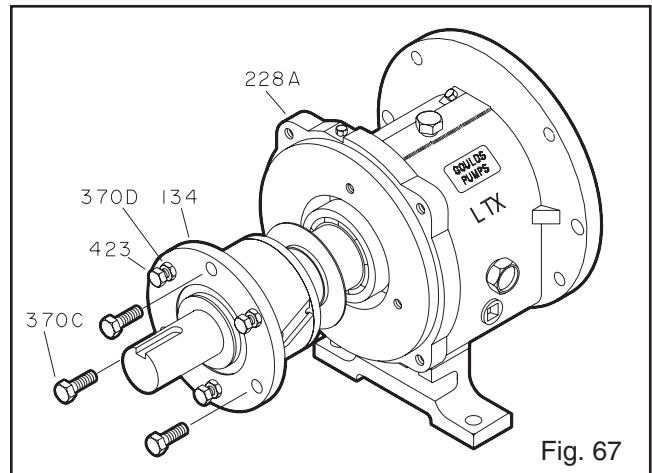



- Remove jack screws (370D) with nuts (423) (Fig. 68).
- Remove clamp ring screws (236A). Separate clamp ring (253B) from bearing housing (134).

**NOTE: Clamp ring cannot be removed from the shaft until bearings are removed.**

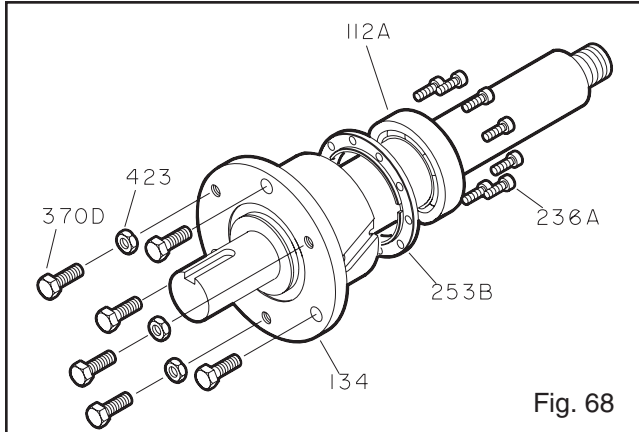

Fig. 68

- Remove bearing housing (134) from shaft (122) with bearings (112A, 168A) (Fig. 69).

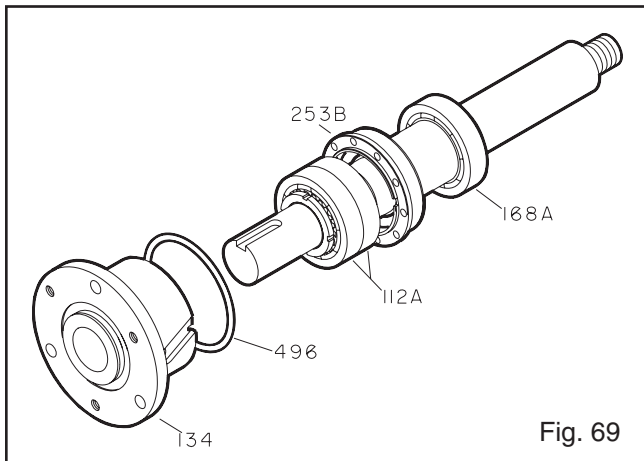

Fig. 69

- Remove bearing housing O-ring (496).
- Remove inboard bearing (168A) (Fig. 70).

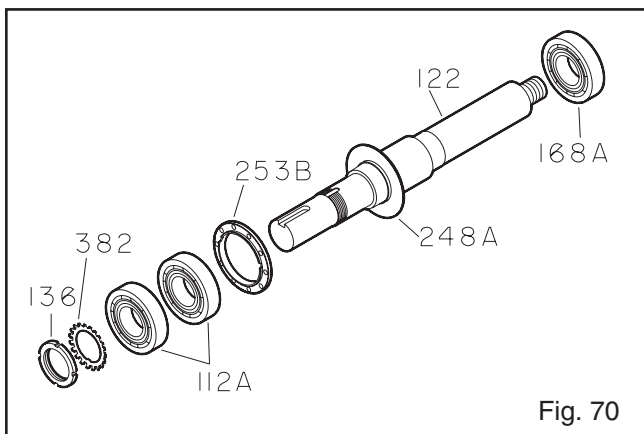

Fig. 70

- Remove bearing locknut (136) and bearing lockwasher (382).
- Remove outboard bearings (112A). Remove clamp ring (253B).

**NOTE: When pressing bearings off shaft, use force on inner race only.**

**NOTE: Save bearings for inspection. Do not reuse bearings.**

**NOTE: Do not remove oil flinger (248A) unless it is damaged.**

- Remove outboard labyrinth seal (332A) from bearing housing (134). Remove O-rings (497F), (497G) if necessary (Fig. 71).

**NOTE: Labyrinth oil seal O-rings (497F, G) are part of 3196 maintenance kits or can be obtained separately.**

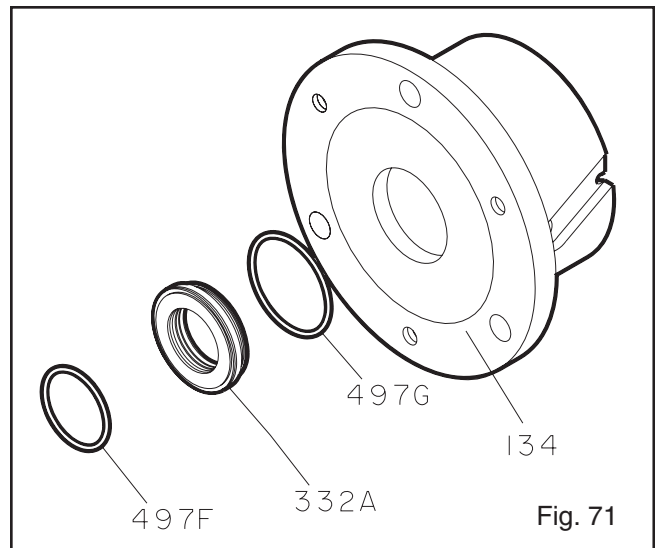
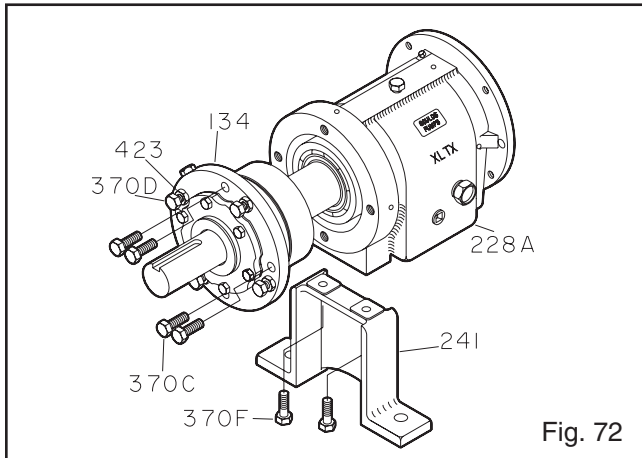

Fig. 71

## DISASSEMBLY OF THE POWER END - XLT-X, X17

1. Remove bearing frame to frame foot bolts (370F) and frame foot (241) (Fig. 72).



2. Remove clamp screws (370C). Back off jam nuts (423). Tighten jack screws (370D) evenly, this will start bearing housing (134) out of bearing frame (228A).
3. Remove shaft assembly from bearing frame (228A).
4. Remove jack screws (370D) with nuts (423) (Fig. 73).
5. Remove bearing housing O-ring (496).
6. Remove inboard bearing (168A).

**NOTE: When pressing bearings off shaft, use force on inner race only.**

**NOTE: Save bearings for inspection.**

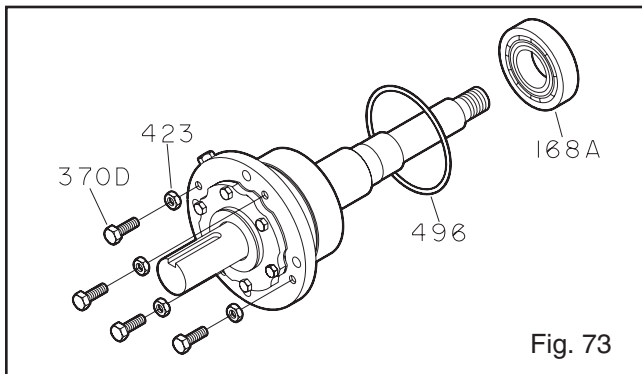

7. Remove bolts (371C), bearing end cover (109A) and gasket (360C) (Fig. 74).
8. Remove outboard labyrinth seal (332A) from end cover (109A). Remove O-rings (497F), (497G) if necessary.

**NOTE: Labyrinth oil seal O-rings (497F, G) are part of 3196 maintenance kits or can be obtained separately.**

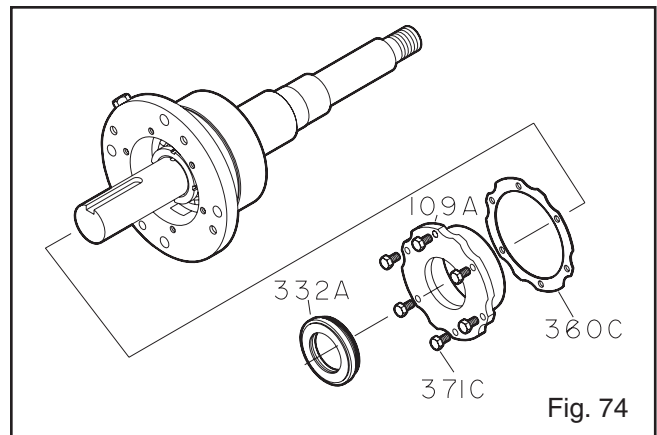

9. Remove bearing housing (134) from shaft (122) with bearing (112A) (Fig. 75).

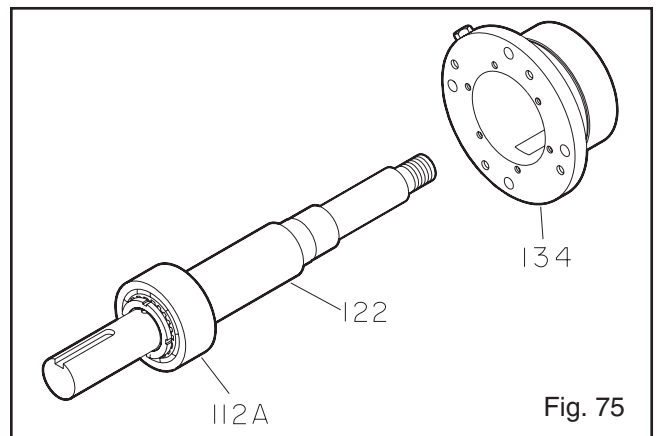

10. Remove bearing locknut (136) and bearing lockwasher (382) (Fig. 76).

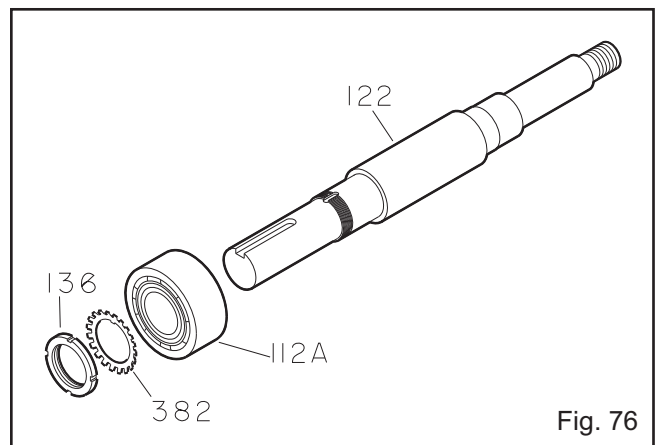

11. Remove outboard bearing (112A).

**NOTE: When pressing bearings off shaft, use force on inner race only.**

**NOTE: Save bearings for inspection.**

## DISASSEMBLY OF POWER END - STX, MTX with Duplex Bearings

1. Remove clamp screws (370C). Back off jam nuts (423). Tighten jack screws (370D) evenly, this will start bearing housing (134) out of bearing frame (228A) (Fig. 77).
2. Remove shaft assembly from bearing frame (228A).

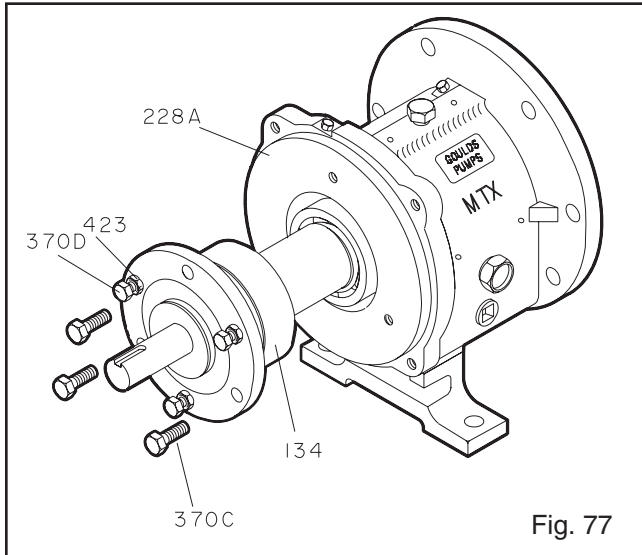

3. Remove jack screws (370D) with nuts (423) (Fig. 78).

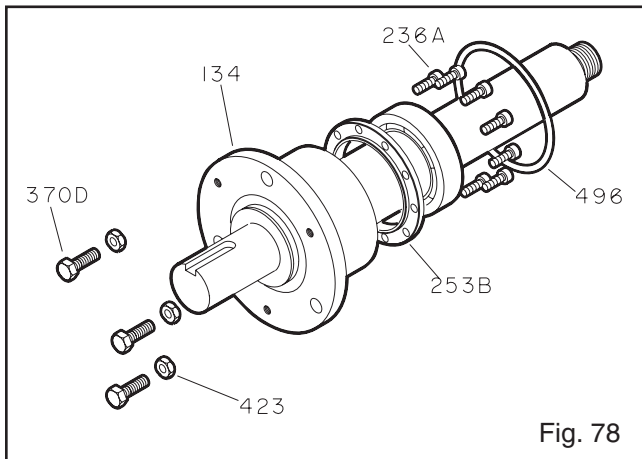

4. Remove bearing housing O-ring (496).
5. Remove clamp ring screws (236A). Separate clamp ring (253B) from bearing housing (134).

**NOTE: Clamp ring cannot be removed from the shaft until bearings are removed.**

6. Remove bearing housing (134) from shaft (122) with bearings (112A, 168A) (Fig. 79).

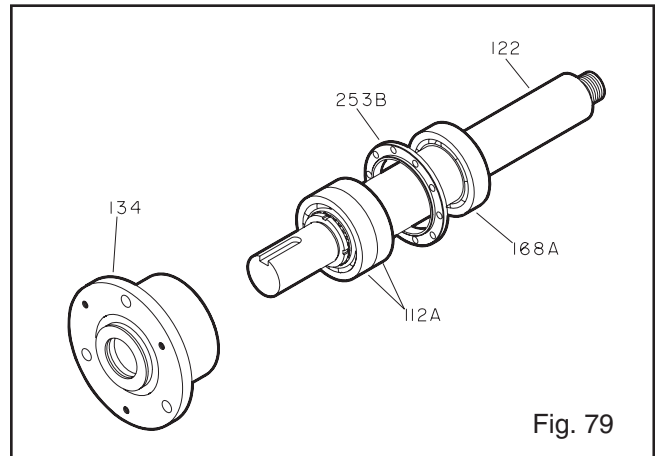

7. Remove inboard bearing (168A) (Fig. 80).

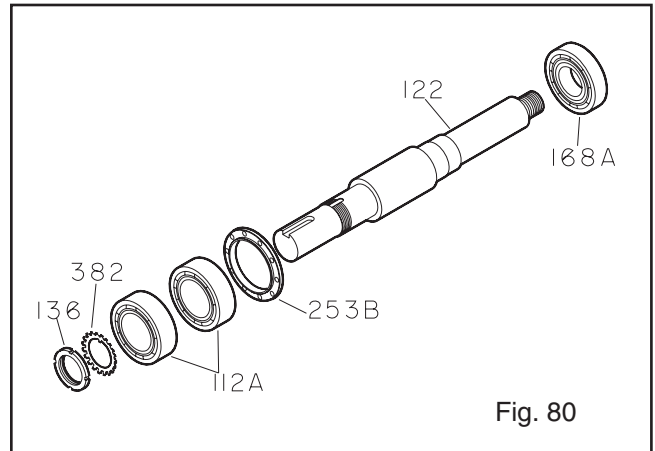

8. Remove bearing locknut (136) and bearing lockwasher (382).
9. Remove outboard bearings (112A).

**NOTE: When pressing bearings off shaft, use force on inner race only.**

**NOTE: Save bearings for inspection.**

- Remove outboard labyrinth seal (332A) from bearing housing (134). Remove O-rings (497F), (497G) if necessary (Fig. 81).

**NOTE: Labyrinth oil seal O-rings (497F, G) are part of 3196 maintenance kits or can be obtained separately.**

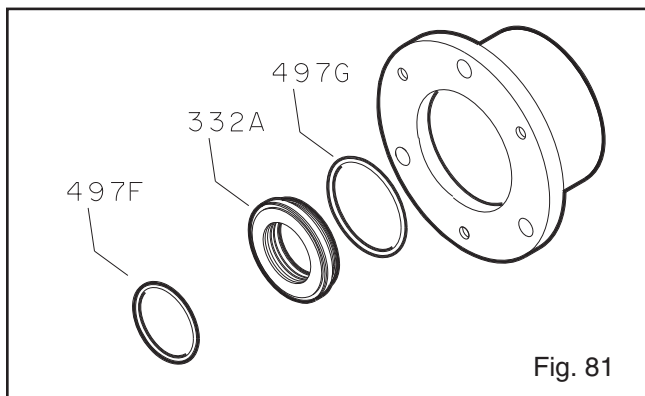

Fig. 81

### DISASSEMBLY OF POWER END - XLT-X, X17 With Duplex Bearings

- Remove bearing frame to frame foot bolts (370F) and frame foot (241) (Fig. 82).

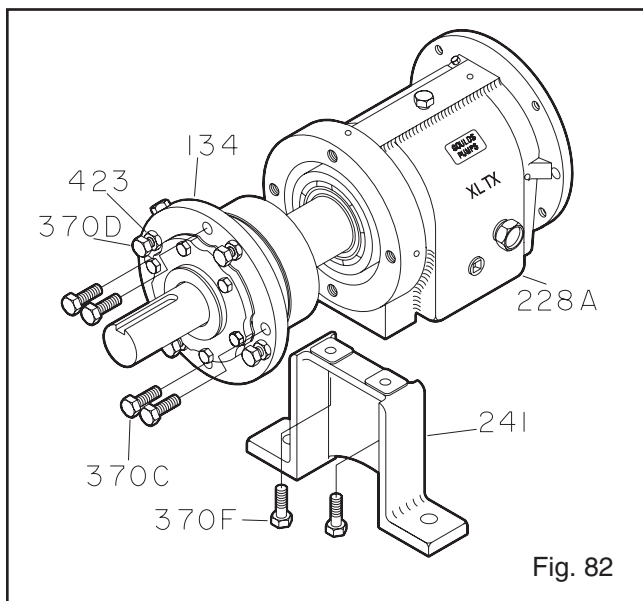

Fig. 82

- Remove clamp screws (370C). Back off jam nuts (423). Tighten jack screws (370D) evenly, this will start bearing housing (134) out of bearing frame (228A).
- Remove shaft assembly from bearing frame (228A).

- Remove jack screws (370D) with nuts (423) (Fig. 83).
- Remove bearing housing O-ring (496).
- Remove inboard bearing (168A).

**NOTE: When pressing bearings off shaft, use force on inner race only.**

**NOTE: Save bearings for inspection.**

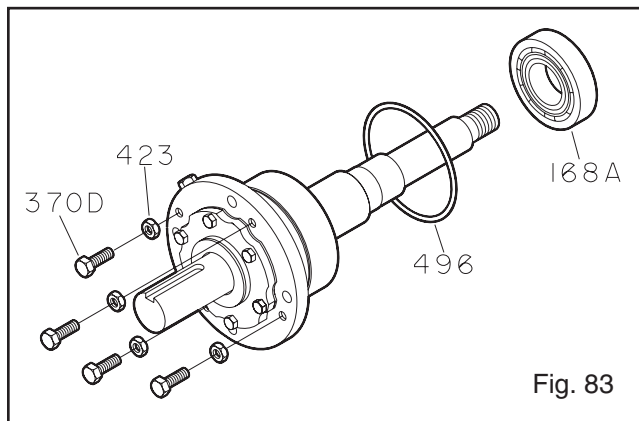

Fig. 83

- Remove bolts (371C), end cover (109A) and gasket (360C) (Fig. 84).
- Remove outboard labyrinth seal (332A) from end cover (109A). Remove O-rings (497F), (497G) if necessary.

**NOTE: Labyrinth oil seal O-rings (497F, G) are part of 3196 maintenance kits or can be obtained separately.**

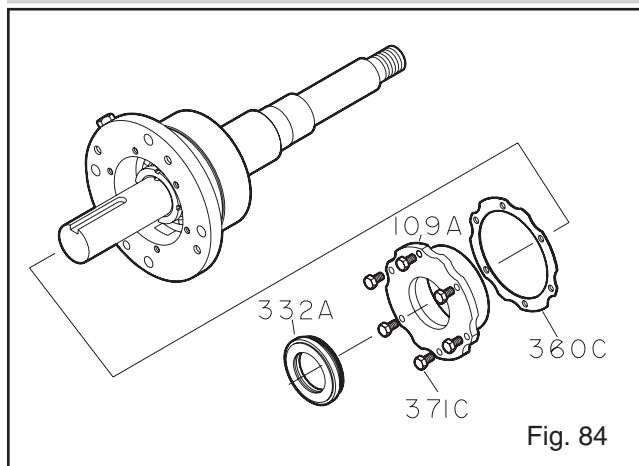
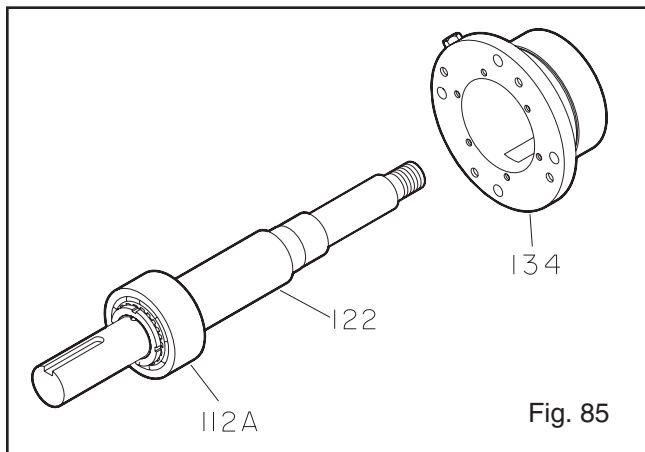
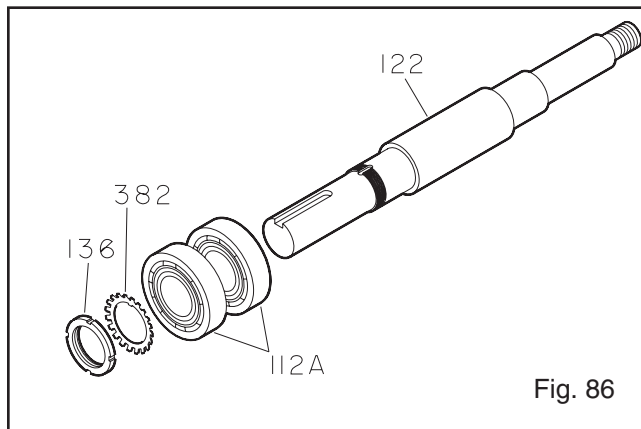

Fig. 84

- Remove bearing housing (134) from shaft (122) with bearings (112A) (Fig. 85).



- Remove bearing locknut (136) and bearing lockwasher (382) (Fig. 86).



- Remove outboard bearing (112A).

**NOTE:** When pressing bearings off the shaft, use force on the inner race only.

**NOTE:** Save bearings for inspection.

## ALL MODELS

### DISASSEMBLY OF BEARING FRAME

- Remove oil fill plug (113A), oil drain plug (408A), sight glass (319), sight oiler plug (408J), four (4) oil mist/grease connection plugs (408H), and oil cooler inlet and outlet plugs (408L, 408M) or oil cooler from bearing frame (228A).
- MTX, LTX: Remove bearing frame foot-to-frame bolts (370F), and frame foot (241).

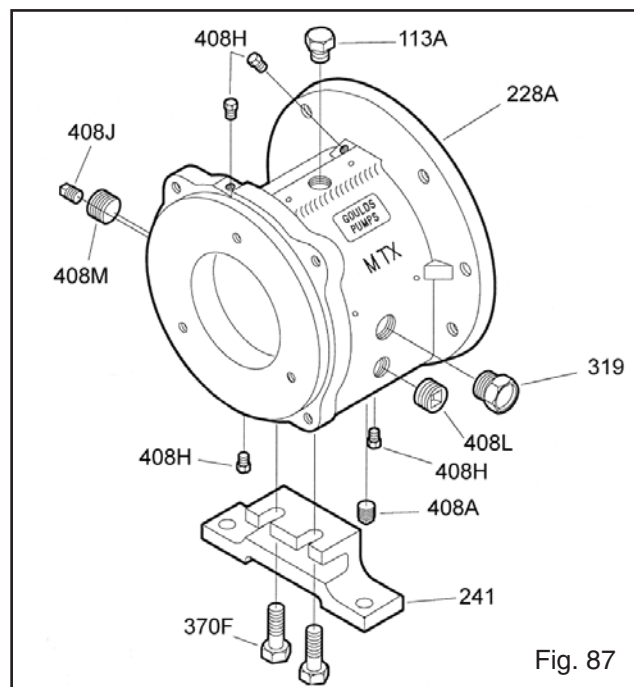

# INSPECTIONS

The pump parts must be inspected to the following criteria before they are reassembled to insure the pump will run properly. Any part not meeting the required criteria should be replaced.

**NOTE: Clean parts in solvent to remove oil, grease or dirt. Protect machined surfaces against damage during cleaning.**

## Casing

The casing (100) should be inspected for cracks and excessive wear or pitting. It should be repaired or replaced if it exceeds the following criteria (Figs. 88, 89 & 90).

101

1. Localized wear or grooving greater than 1/8 in. (3.2 mm) deep.
2. Pitting greater than 1/8 in. (3.2 mm) deep.
3. Inspect case gasket seat surface for irregularities.

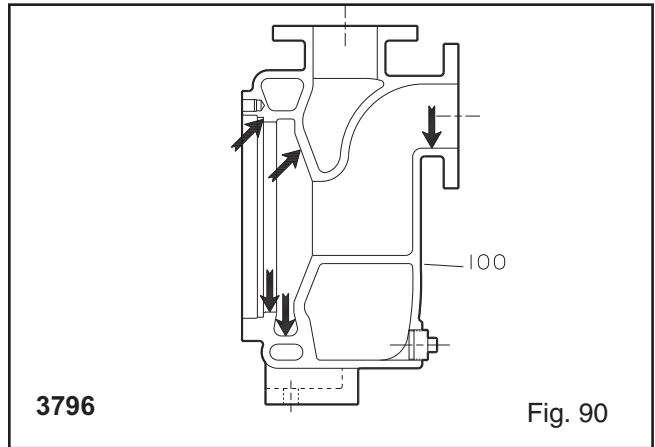
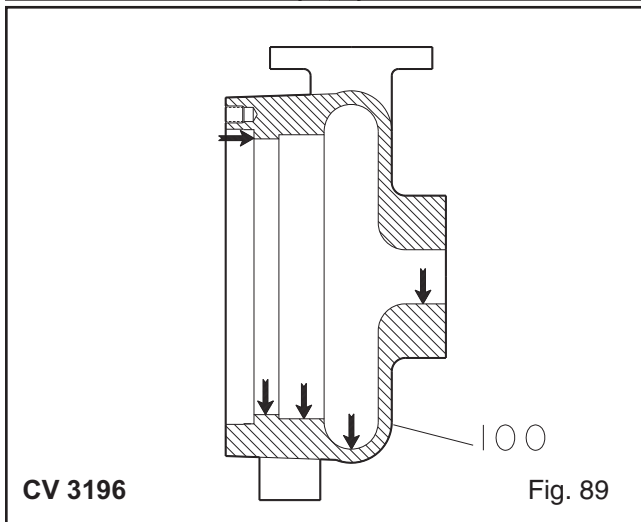
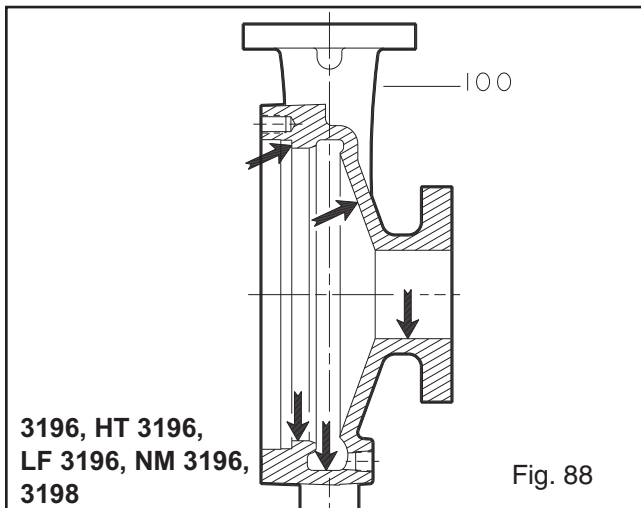

## Impeller

1. Inspect impeller (101) vanes for damage. Replace if grooved deeper than 1/16 in. (1.6 mm) or if worn evenly more than 1/32 in. (0.8 mm). (Area "a" in Fig. 91).
2. Inspect pumpout vanes for damage. Replace if worn more than 1/32 in. (0.8 mm). (Area "b" in Fig. 91).
3. Inspect leading and trailing edges of the vanes for cracks, pitting, and erosion or corrosion damage. (Area "c" in Fig. 91.).

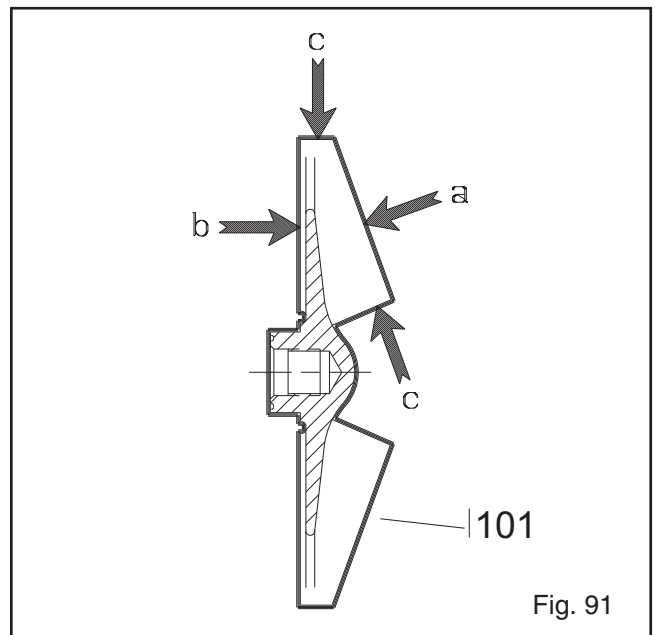

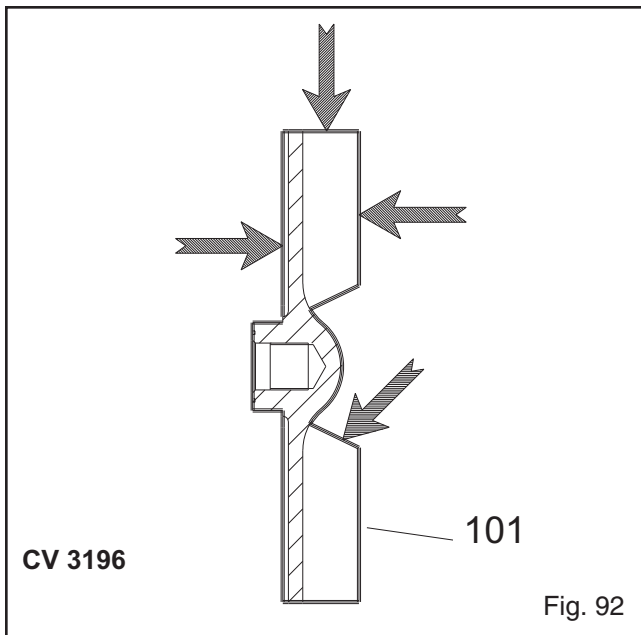

**NOTE:** For CV 3196 impeller, the face of the impeller is cast, not machined. The face runout need not be checked.

### Frame Adapter

1. Check frame adapter (108) for cracks or excessive corrosion damage. Replace if any of these conditions exist (Fig. 93).
2. Make sure gasket surface is clean.

**NOTE:** The 3198 frame adapter is not interchangeable with any other model's adapter.

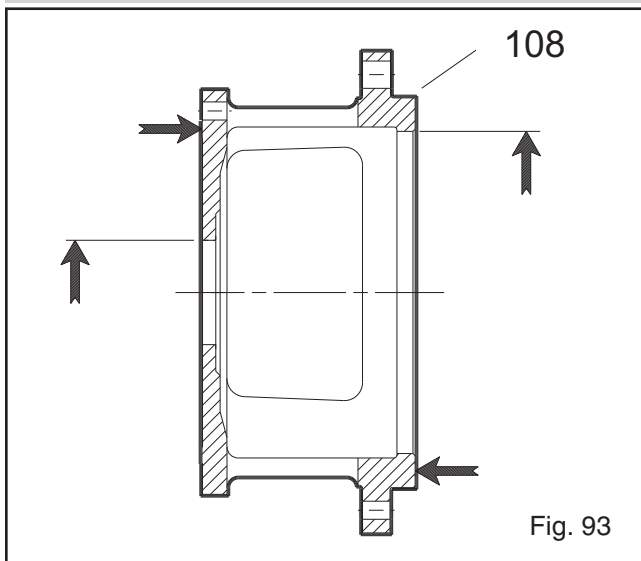

### Shaft and Sleeve - All Except 3198

1. Check bearing fits. If any are outside the tolerance in Table 8, replace the shaft (122) (Fig. 94).
2. Check shaft straightness. Replace shaft if runout exceeds values in Table 12.
3. Check shaft and sleeve (126) surface for grooves, pitting. Replace if any are found (Fig. 95).

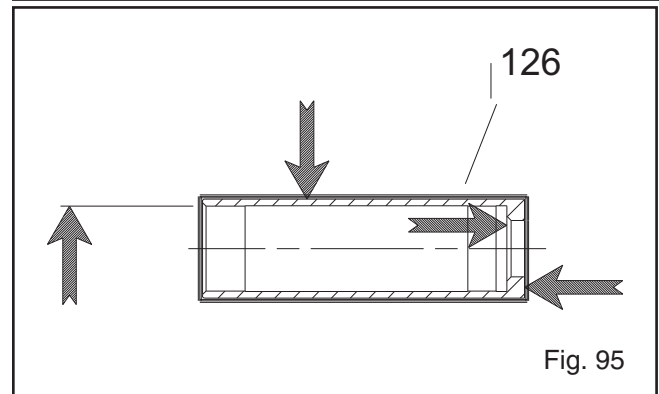
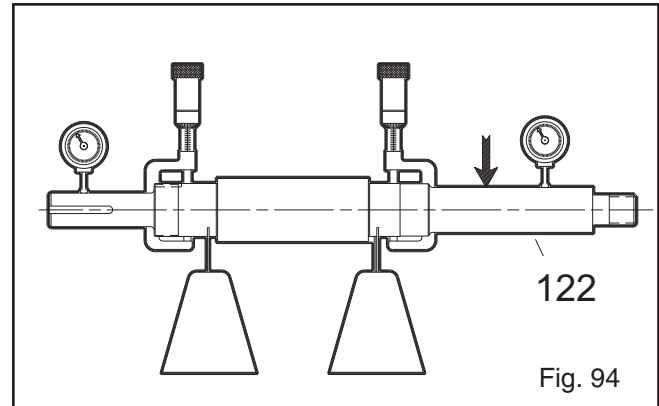

### Shaft and Sleeve - 3198

The 3198 is offered with a metallic sleeve which uses the standard 3196 (ANSI products) shaft. It is also offered with a Teflon® sleeve. The use of the Teflon® sleeve requires a special shaft and a different inboard labyrinth oil seal. The inspection procedures are the same as those listed above for the balance of the products.

## Bearing Frame

1. Visually inspect bearing frame (228) and frame foot (241) for cracks. Check frame inside surfaces for rust, scale or debris. Remove all loose and foreign material (Figs. 96, 97).
2. Make sure all lubrication passages are clear.
3. If frame has been exposed to pumpage, inspect for corrosion or pitting.
4. Inspect inboard bearing bore according to Table 8.

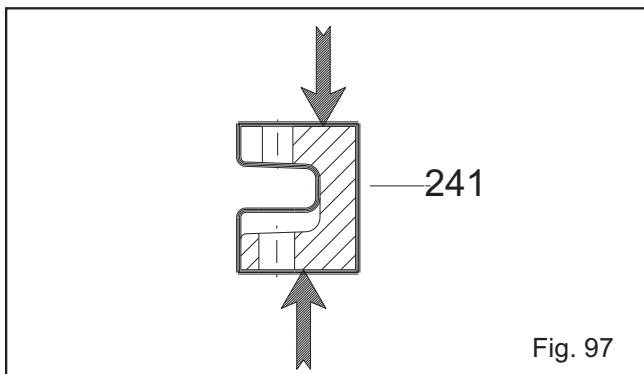
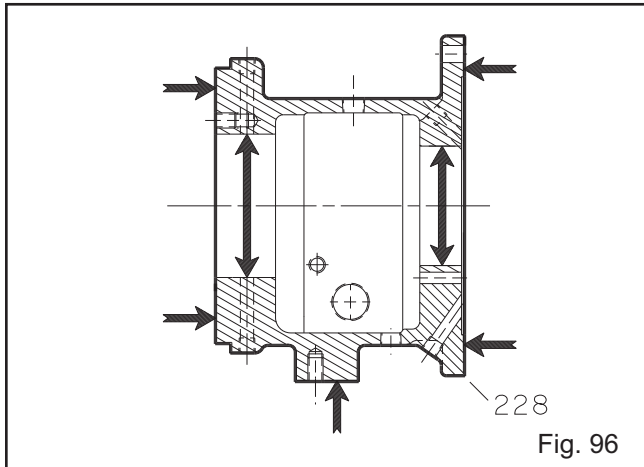

## C-Face Adapter

For C-Face adapter inspections, See *Appendix V*.

## Dynamic Seal Repeller

(3196, CV 3196, LF 3196 only)

1. Inspect dynamic seal repeller (262) vanes for damage. Replace if grooved deeper than 1/16 in. (1.6 mm) or if worn evenly more than 1/32 in. (0.8 mm) (Fig. 98).
2. Inspect sleeve surface for grooves, pitting or other damage. Replace if damaged.

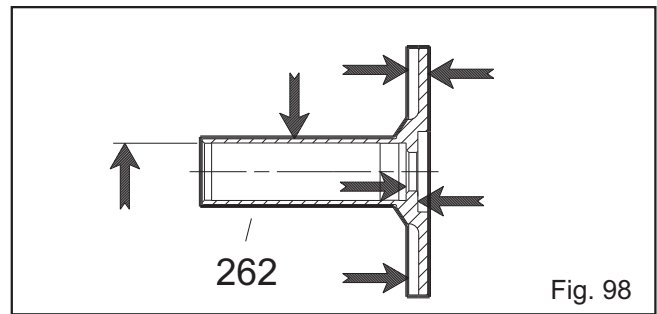

## Seal Chamber/Stuffing Box Cover and Dynamic Seal Backplate

1. Make sure seal chamber/stuffing box cover (184) and dynamic seal backplate (444) gasket surfaces, and mounting surfaces, are clean (Figs. 99 - 107).
2. Replace if there is any pitting or wear greater than 1/8 in. (3.2 mm) deep.
3. Inspect machined surfaces and mating faces noted on Figures 99-107, and clean as necessary.

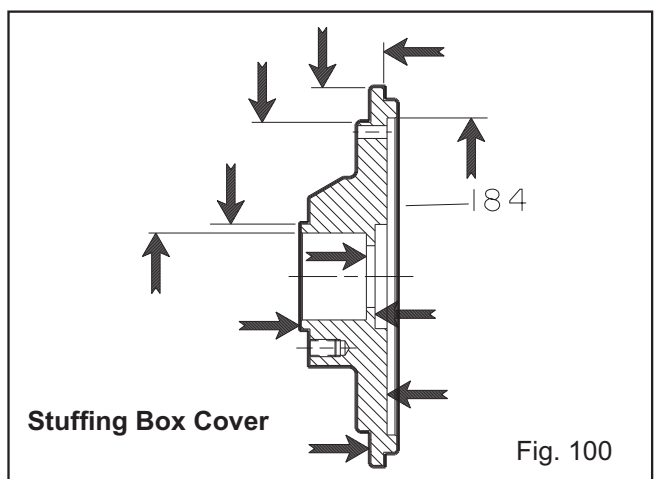
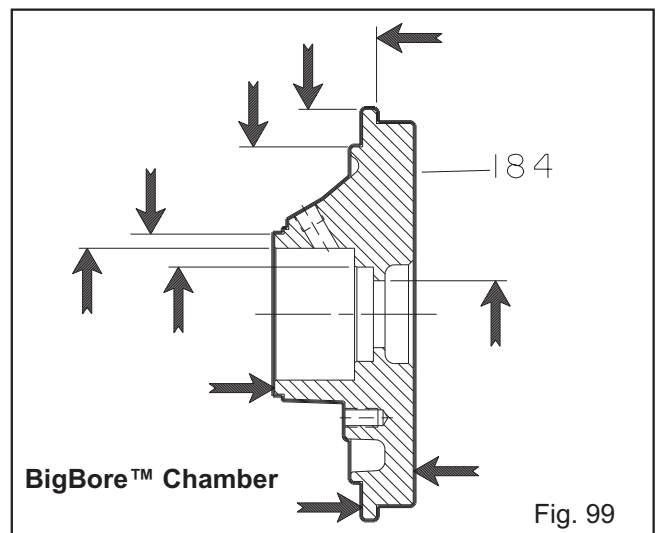



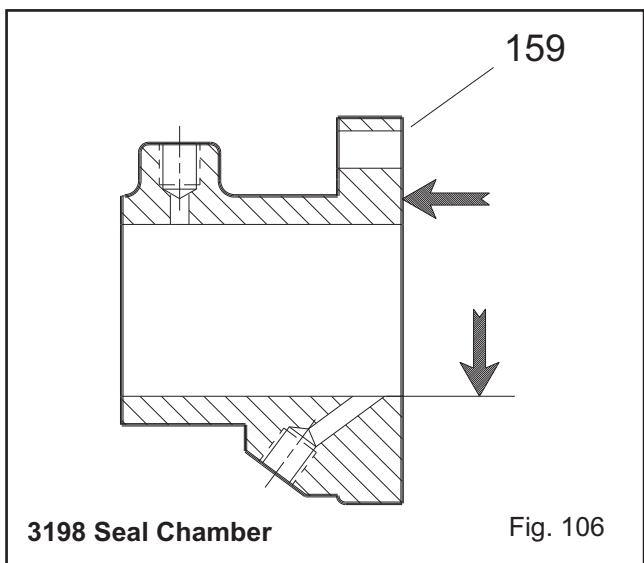
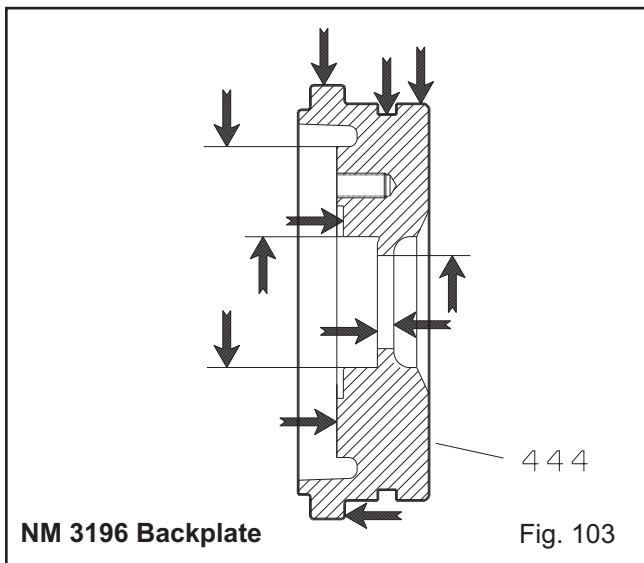
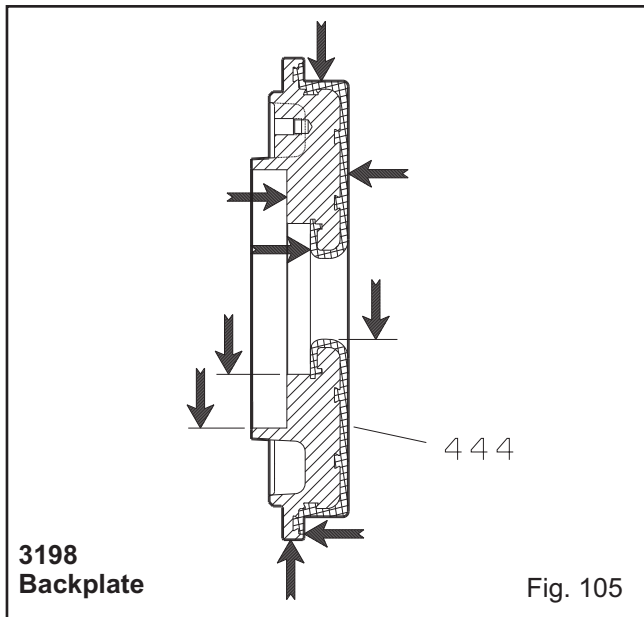
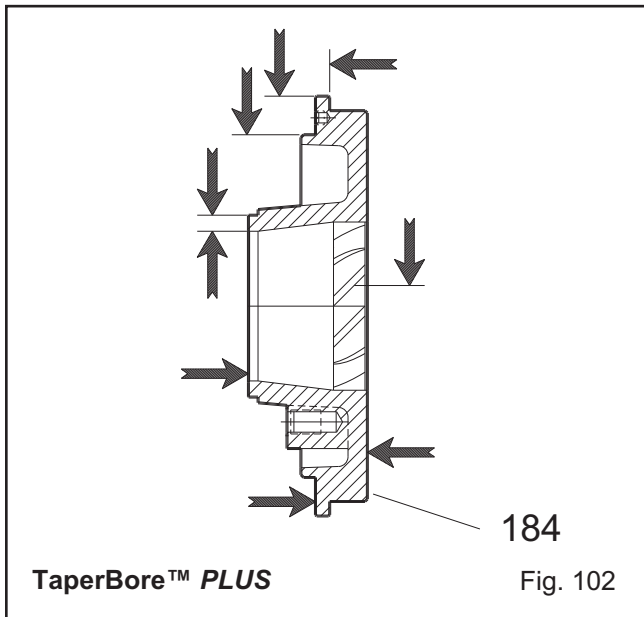
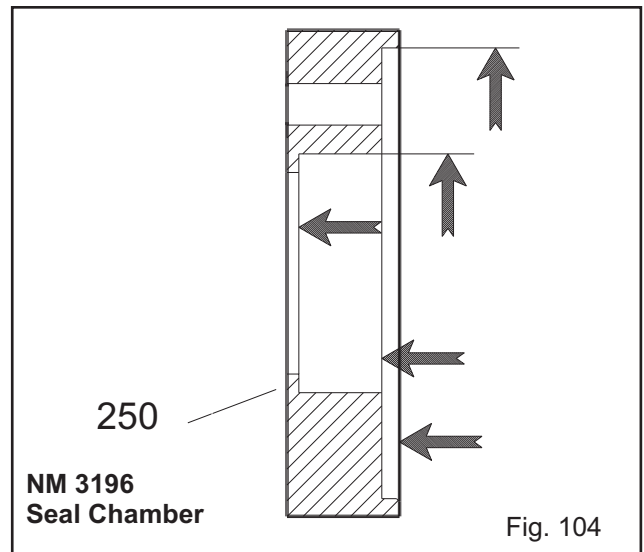
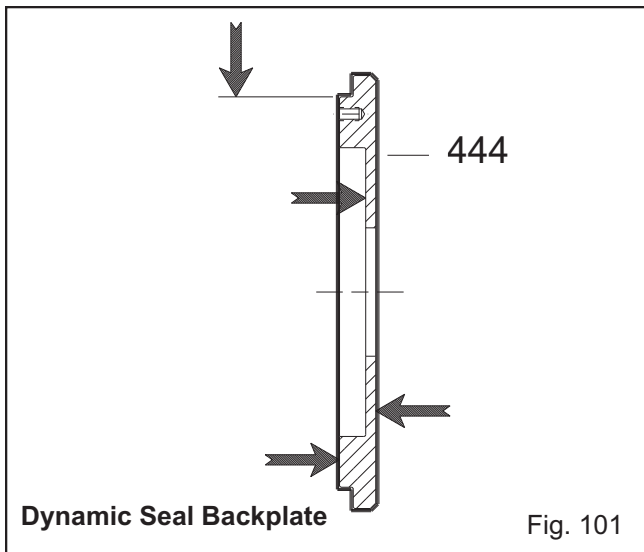

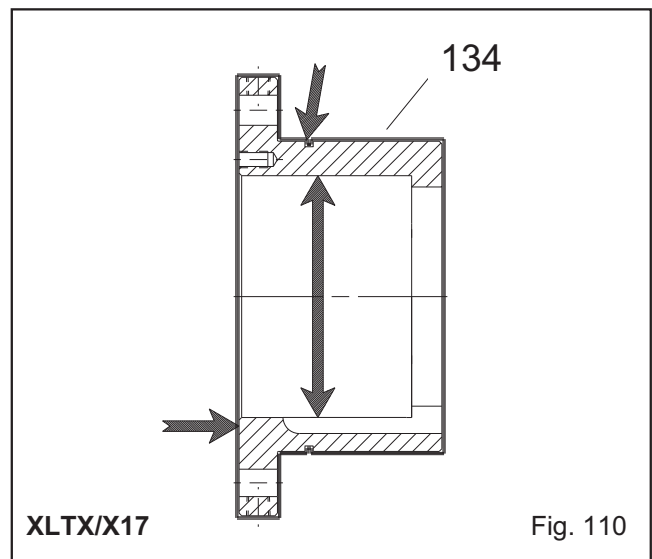
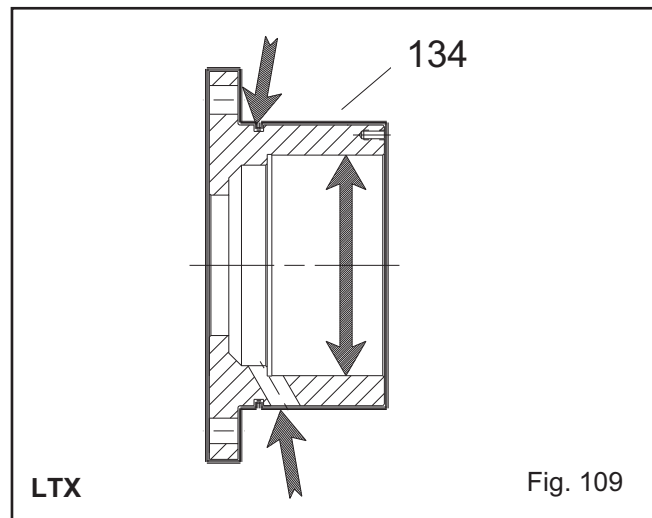
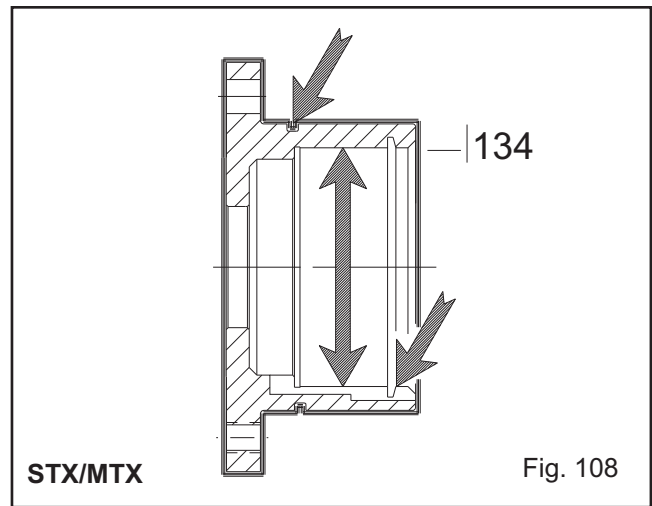
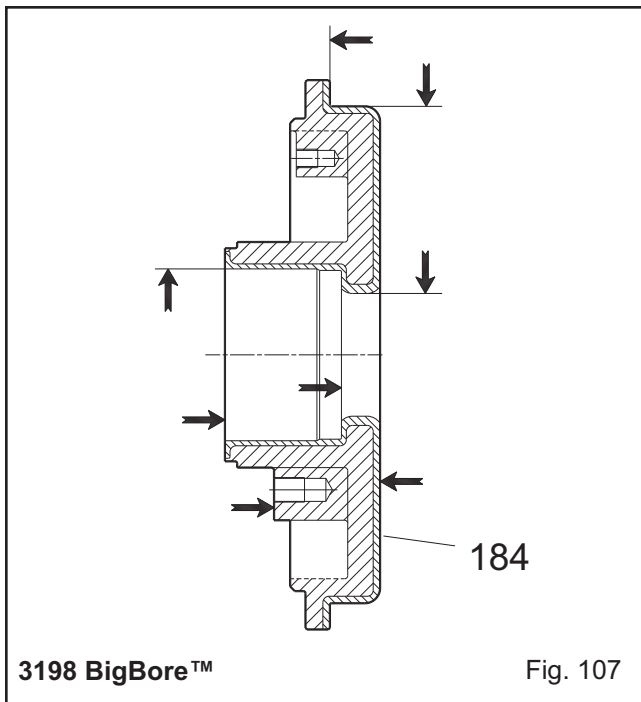

## Bearings

1. Ball bearings (112A, 168A) should be inspected for contamination and damage. The condition of the bearings will provide useful information on operating conditions in the bearing frame. Lubricant condition and residue should be noted, oil analysis is often helpful. Bearing damage should be investigated to determine cause. If cause is not normal wear, it should be corrected before pump is returned to service.

### DO NOT RE-USE BEARINGS.

## Bearing Housing

1. Inspect bearing housing (134) bore according to *Table 8*. Replace if dimensions exceed *Table 8* values.
2. Visually inspect for cracks and pits.
  - STX, MTX* - Snap ring groove must not be cracked (Fig. 108).
  - LTX* - Grooves and holes must be clear (Fig. 109).
  - XLTX-X, X17* - Gasket surface must be clean (Fig. 110).

## Labyrinth Seals

1. Labyrinth seal (332A, 333A) O-rings should be inspected for cuts and cracks. Replace as needed.

**Table 8  
Bearing Fits & Tolerances**

**According to ABEC I standard**

	<b>STX in. (mm)</b>	<b>MTX in. (mm)</b>	<b>LTX in. (mm)</b>	<b>XLT-X, X-17 in. (mm)</b>
<b>Shaft O.D. Inboard</b>	1.3785 (35.013) 1.3781 (35.002)	1.7722 (45.013) 1.7718 (45.002)	2.1660 (55.015) 2.1655 (55.002)	2.5597 (65.015) 2.5592 (65.002)
<b>Clearance</b>	0.0010 (0.025) tight 0.0001 (0.002) tight	0.0010 (0.025) tight 0.0001 (0.002) tight	0.0012 (0.030) tight 0.0001 (0.002) tight	0.0012 (0.030) tight 0.0001 (0.002) tight
<b>Bearing I.D. Inboard</b>	1.3780 (35.000) 1.3775 (34.988)	1.7717 (45.000) 1.7712 (44.988)	2.1654 (55.000) 2.1648 (54.985)	2.5591 (65.000) 2.5585 (64.985)
<b>Frame I.D. Inboard</b>	2.8346 (72.000) 2.8353 (72.019)	3.9370 (100.000) 3.9379 (100.022)	4.7244 (120.000) 4.7253 (120.022)	5.5118 (140.000) 5.5128 (140.025)
<b>Clearance</b>	0.0012 (0.032) loose 0.0000 (0.000) loose	0.0015 (0.037) loose 0.0000 (0.000) loose	0.0015 (0.037) loose 0.0000 (0.000) loose	0.0017 (0.043) loose 0.0000 (0.000) loose
<b>Bearing O.D. Inboard</b>	2.8346 (72.000) 2.8341 (71.987)	3.9370 (100.000) 3.9364 (99.985)	4.7244 (120.000) 4.7238 (119.985)	5.5118 (140.000) 5.5111 (139.982)
<b>Shaft O.D. Outboard</b>	1.1815 (30.011) 1.1812 (30.002)	1.7722 (45.013) 1.7718 (45.002)	1.9690 (50.013) 1.9686 (50.002)	2.5597 (65.015) 2.5592 (65.002)
<b>Clearance</b>	0.0008 (0.021) tight 0.0001 (0.002) tight	0.0010 (0.025) tight 0.0001 (0.002) tight	0.0010 (0.025) tight 0.0001 (0.002) tight	0.0012 (0.030) tight 0.0001 (0.002) tight
<b>Bearing I.D. Outboard</b>	1.1811 (30.000) 1.1807 (29.990)	1.7717 (45.000) 1.7712 (44.988)	1.9685 (50.000) 1.9680 (49.988)	2.5591 (65.000) 2.5585 (64.985)
<b>Housing I.D. Outboard</b>	2.8346 (72.000) 2.8353 (72.019)	3.9370 (100.000) 3.9379 (100.022)	4.3307 (110.000) 4.3316 (110.022)	5.5118 (140.000) 5.5128 (140.025)
<b>Clearance</b>	0.0012 (0.032) loose 0.0000 (0.000) loose	0.0015 (0.037) loose 0.0000 (0.000) loose	0.0015 (0.037) loose 0.0000 (0.000) loose	0.0017 (0.043) loose 0.0000 (0.000) loose
<b>Bearing O.D. Outboard</b>	2.8346 (72.000) 2.8341 (71.987)	3.9370 (100.000) 3.9364 (99.985)	4.3307 (110.000) 4.3301 (109.985)	5.5118 (140.000) 5.5111 (139.982)

# REASSEMBLY

Refer to *Table 9 and 9a* for torque values while reassembling pump.

**Table 9  
Bolt Torque, Ft-Lbs (Nm)**

Location	Frame	3196, CV 3196, LF 3196, 3796		NM 3196		3198	
		Lube	Dry	Lube	Dry	Lube	Dry
Casing Bolts (370) or Casing Nuts (425)	6" STX	<b>Refer to Table 9a</b>		27 (36)	40 (53)	N/A	N/A
	8" STX			20 (27)	30 (40)	35 (47)	53 (71)
	MTX, LTX			27 (36)	40 (53)	35 (47)	53 (71)
	XLT-X, X17			N/A	N/A	N/A	N/A
Frame-to-Adapter	All	20 (27)	30 (40)	20 (27)	30 (40)	20 (27)	30 (40)
Bearing Clamp Ring Bolts (236A) Duplex Bearing Only	STX, MTX	10* (1.1)	17* (1.9)	10* (1.1)	17* (1.9)	10* (1.1)	17* (1.9)
	LTX	55* (6.2)	83* (9.4)	55* (6.2)	83* (9.4)	55* (6.2)	83* (9.4)
Bearing End Cover Bolts (371C)	XLT-X, X17	9 (12)	12 (16)	N/A	N/A	N/A	N/A
Dynamic Seal Capscrews (265)	STX, MTX, LTX	55* (6.2)	83* (9.4)	N/A	N/A	N/A	N/A
	XLT-X, X17	9 (12)	12 (16)	N/A	N/A	N/A	N/A

**Table 9a  
Maximum Torque Values in ft.-lb. (Nm)  
for Casing Bolts (370)**

		Models 3196, CV 3196 LF 3196, 3796 with 150 lb. Casing flanges				Model HT 3196 and all Models with 300 lb. Casing flanges	
		Material Specification					
Frame	Casing Bolt Diameter (in.)	Ductile Iron Casing with A 307 Grade B casing bolts		Alloy Casing with (304SS) F593 Grade 1 or (316SS F593) Grade 2 casing bolts		Ductile Iron and Alloy Casings with A193 grade B7 casing bolts	
		Lube	Dry	Lube	Dry	Lube	Dry
8" STX	1/2"	20 (27)	30 (41)	35 (47)	54 (73)	58 (79)	87 (118)
6" STX MTX LTX XLT-X	5/8"	39 (53)	59 (80)	71 (96)	107 (145)	115 (156)	173 (235)
X17	7/8"	113 (153)	170 (231)	141 (191)	212 (287)	330 (447)	495 (671)

\* Values are in inch-lbs (Nm)

Refer to *Table 10* for shaft end play while reassembling pump.

	<b>STX in. (mm)</b>	<b>MTX in. (mm)</b>	<b>LTX in. (mm)</b>	<b>XLT-X in. (mm)</b>
Double Row	.0011 (.028) .0019 (.047)	.0013 (.033) .0021 (.054)	not applicable	.0014 (.036) .0023 (.058)
Duplex	.0007 (.018) .0010 (.026)	.0009 (.022) .0012 (.030)	.0010 (.026) .0015 (.038)	.0010 (.026) .0015 (.038)

Frame	Inboard	Outboard	
		Double Row	Duplex
STX	6207	5306	7306
MTX	6309	5309	7309
LTX	6311	not applicable	7310
XLT-X, X17	6313	5313	7313

	<b>Sleeve Fit in. (mm)</b>	<b>Coupling Fit in. (mm)</b>
With Sleeve	.001 (.026)	.001 (.026)
Less Sleeve	.002 (.051)	.001 (.026)

**NOTE:** Bearing type is based on SKF/MRC designation.

### Assembly of Rotating Element and Bearing Frame STX, MTX

**NOTE:** Make sure that threads are clean and apply thread sealant to pipe threads and fittings.

1. Install oil fill plug (113A), oil drain plug (408A), sight window (319), sight oiler plug (408J), four oil mist connection plugs (408H) or grease fittings (193) and relief plugs (113), and oil cooler inlet and outlet plugs or oil cooler (408L, 408M) in bearing frame (228) (Fig. 111).
2. Attach bearing frame foot (241) with bolts (370F). Hand tighten.

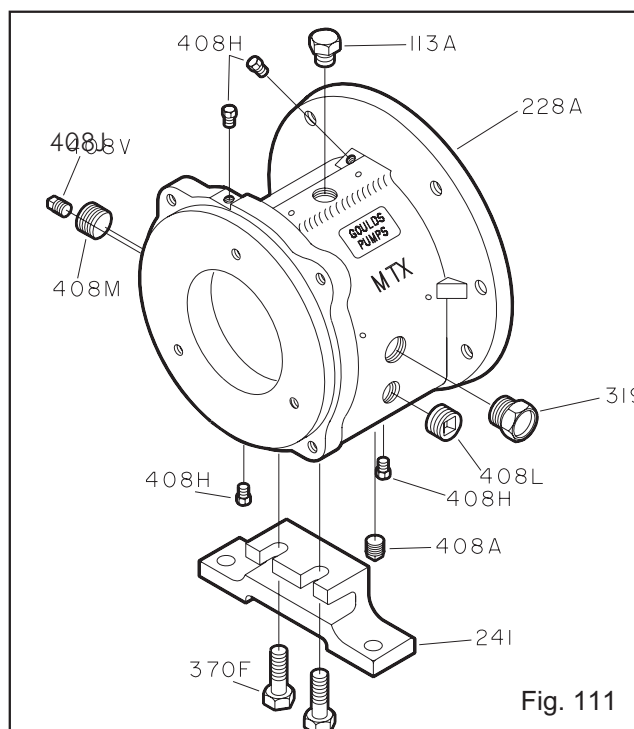

3. Install outboard bearing (112A) on shaft (122) (Fig. 112).

**NOTE:** Refer to Appendix VII-1 for detailed outboard bearing installation instructions.

**NOTE:** Regreaseable bearing has a single shield. The outboard bearing is installed with shield toward impeller.

**NOTE:** There are several methods used to install bearings. The recommended method is to use an induction heater that heats as well as demagnetizes the bearings.



### WARNING

**Wear insulated gloves when using a bearing heater. Bearings will get hot and can cause physical injury.**

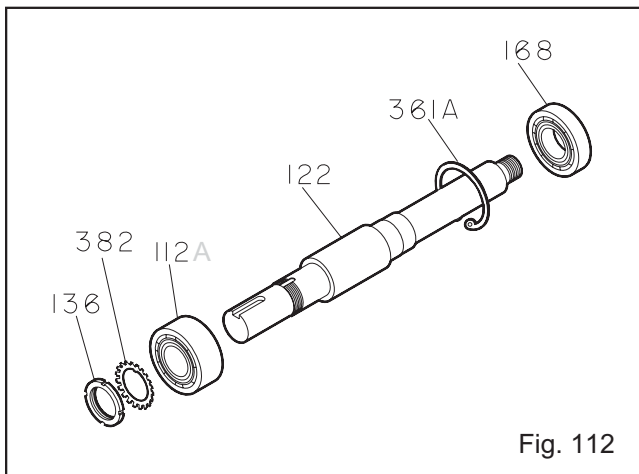

Fig. 112

4. Place lockwasher (382) on shaft (122). Place tang of lockwasher in keyway of shaft.
5. Thread locknut (136) onto shaft (122). Tighten locknut until snug. Bend any tang of lockwasher into a slot of locknut.

**NOTE:** Tighten locknut if necessary to align the closest tab of lockwasher with slot on locknut.

6. Place bearing retaining ring (361A) over shaft (122), flat side facing bearing.
7. Install inboard bearing (168A) on shaft (122).

**NOTE:** Regreaseable bearing has a single shield. The inboard bearing is installed with shield away from impeller.

**NOTE:** There are several methods used to install bearings. The recommended method is to use an induction heater that heats as well as demagnetizes the bearings.



### WARNING

**Wear insulated gloves when using a bearing heater. Bearings will get hot and can cause physical injury.**

**NOTE:** Coat internal surfaces of bearings with lubricant to be used in service.

8. Install new O-ring (496) (Fig. 113).

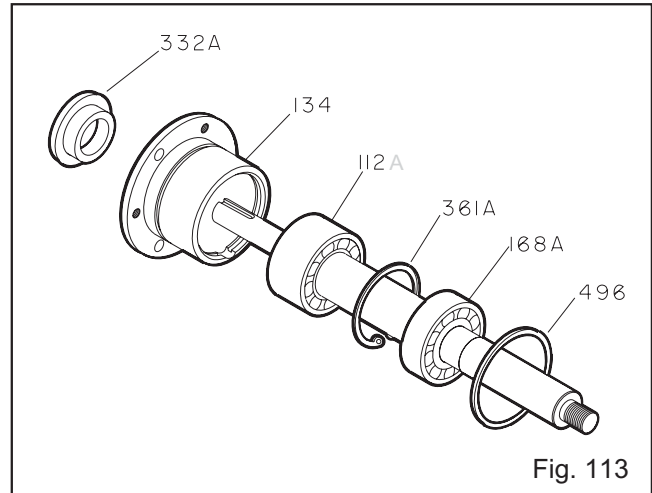

Fig. 113

9. Coat outside of outboard bearing (112A) and bearing housing (134) bore with oil.
10. Install bearing housing (134) onto shaft/bearing assembly.

**NOTE:** Do not force assembly together.

11. Insert retaining ring (361A) into groove in housing (134) bore. Check shaft for free turning.

**NOTE:** The space between the ends of retaining ring should be located in the oil return groove so as not to obstruct oil flow.

12. Install outboard labyrinth oil seal (332A) into bearing housing (134). It is an O-ring fit. Position the labyrinth seal drain slots at the bottom (6 o'clock) position.

**NOTE:** Refer to Appendix IV or VIII for detailed labyrinth seal installation instructions.

**NOTE:** Make sure the keyway edges are free of burrs.

**NOTE:** Cover the keyway lengthwise with a piece of electrical tape prior to installing the labyrinth seal. This will protect the O-rings.

13. Coat outside of bearing housing (134) with oil (Fig. 114).
14. Coat all internal surfaces of bearing frame (228A) with oil.

15. Install shaft assembly into frame (228A), making sure to leave approximately 0.125 in. (3.175 mm) clearance between the face of the bearing housing and bearing frame. Check shaft for free turning.
16. Install clamping bolts (370C) into bearing housing (134). Hand tighten.
17. Install jacking bolts (370D) with locking nuts (423) into housing (134). Hand tighten.

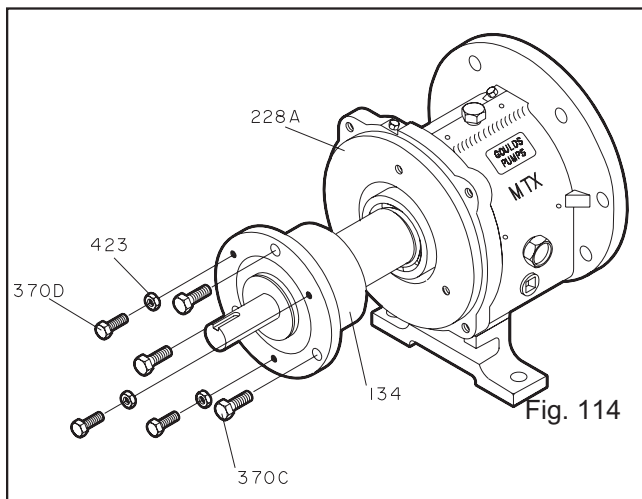

## LTX

**NOTE:** Make sure that threads are clean and apply thread sealant to pipe threads and fittings.

1. Install the oil fill plug (113A), oil drain plug (408A), sight window (319), sight oiler plug (408J), four oil mist connection plugs (408H) or grease fittings (193) and grease relief plugs (113), and oil cooler inlet and outlet plugs or oil cooler (408L, 408M) in bearing frame (228) (Fig. 115).

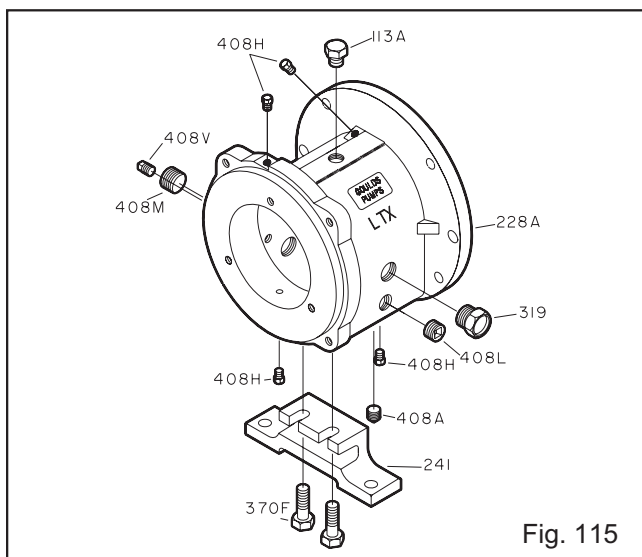

2. Attach bearing frame foot (241) with bolts (370F). Hand tighten.
3. Install oil flinger (248A) on shaft (122) if removed (Fig. 116).

**NOTE:** The oil flinger is a press fit onto shaft. Use a driver of proper size to prevent damage to oil flinger.

4. Place bearing clamp ring (253B) over shaft (122). Note orientation.
5. Install outboard bearings (112A) on shaft (122).

**NOTE:** Refer to Appendix VII-2 for detailed outboard bearing installation instructions.



## CAUTION

The LTX uses duplex bearings mounted back to back. Make sure orientation of the bearings is correct.

**NOTE:** There are several methods used to install bearings. The recommended method is to use an induction heater that heats as well as demagnetizes the bearings.



## WARNING

Wear insulated gloves when using a bearing heater. Bearings will get hot and can cause physical injury.

6. Place lockwasher (382) on shaft (122). Place tang of lockwasher in keyway of shaft.
7. Thread locknut (136) onto shaft (122). Tighten locknut until snug. Bend any tang of lockwasher (382) into a slot of locknut.

**NOTE:** Tighten locknut if necessary to align the closest tab of lockwasher with slot on locknut.

8. Install inboard bearing (168A) on shaft (122).

**NOTE:** Regreaseable bearing has a single shield. The inboard bearing is installed with shield away from impeller.

**NOTE:** There are several methods used to install bearings. The recommended method is to use an induction heater that heats as well as demagnetizes the bearings.



## WARNING

Wear insulated gloves when using a bearing heater. Bearings will get hot and can cause physical injury.

**NOTE:** Coat internal surfaces of bearings with lubricant to be used in service.

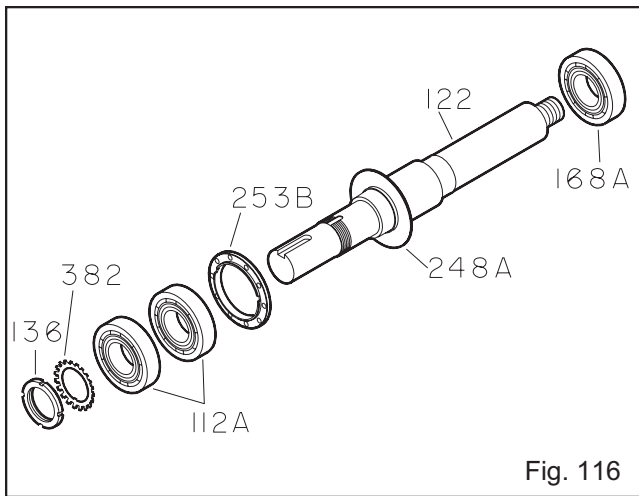

Fig. 116

9. Coat outside of outboard bearing (112A) and bearing housing (134A) bore with oil.
10. Install bearing housing (134) onto shaft/bearing assembly (Fig. 117).

**NOTE: Do not force assembly together.**

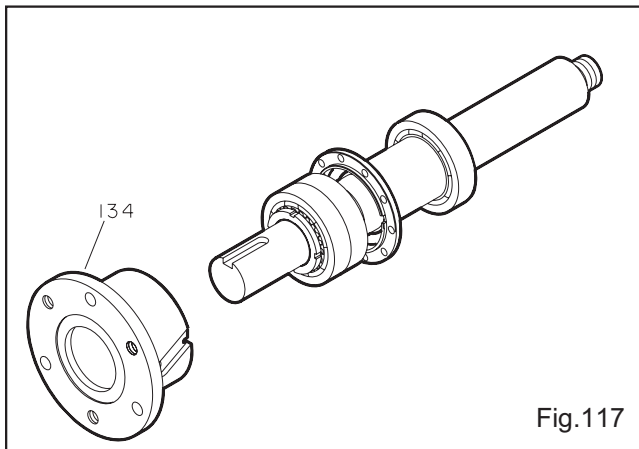

Fig.117

11. Install clamp ring bolts (236A). Check shaft for free turning. Refer to *Table 9* for bolt torque values (Fig. 118).



### CAUTION

**Tighten clamp ring bolts (236A) in a criss cross pattern.**

12. Install new O-ring (496).
13. Install outboard labyrinth oil seal (332A) into bearing housing (134). It is an O-ring fit. Position the labyrinth seal drain slots at the bottom (6 o'clock) position.

**NOTE: See Appendix IV or VIII for further instructions on Labyrinth Seal installation.**

**NOTE: Make sure the keyway edges are free of burrs.**

**NOTE: Cover the keyway lengthwise with a piece of electrical tape prior to installing the labyrinth seal. This will protect the O-rings.**

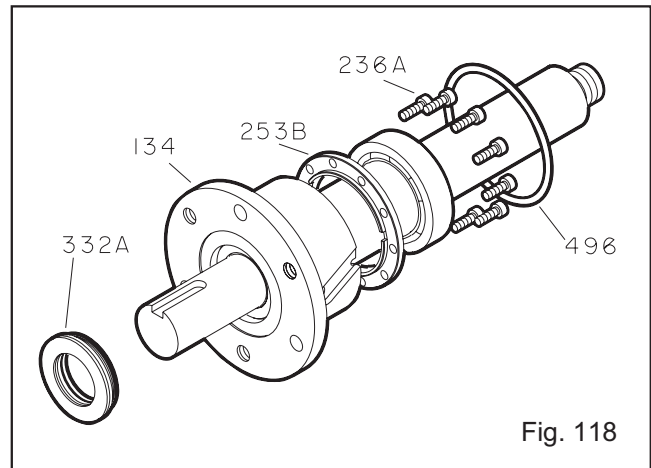

Fig. 118

14. Coat outside of bearing housing (134A) with oil.
15. Coat all internal surfaces of bearing frame (228) with oil.
16. Install shaft assembly into frame (228A), making sure to leave approximately 0.125 in. (3.175 mm) clearance between the face of the bearing housing and bearing frame. Check shaft for free turning (Fig. 119).
17. Install clamping bolts (370C) into bearing housing (134A). Hand tighten.
18. Install jacking bolts (370D) with locking nuts (423) into housing (134A). Hand tighten.

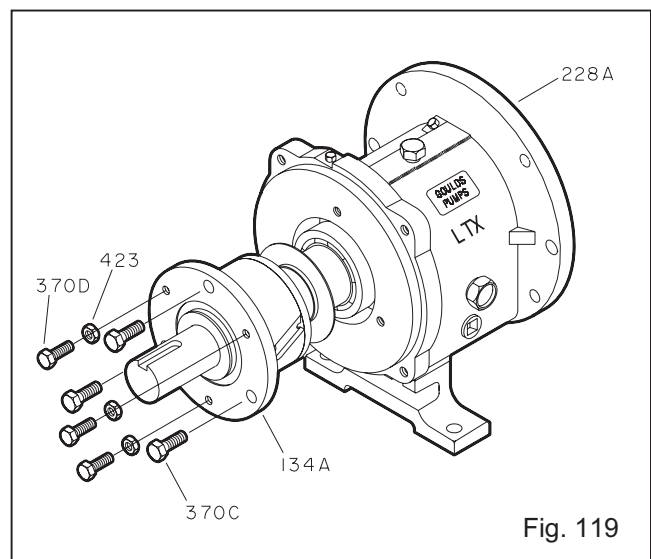

Fig. 119



## XLT-X, X17

**NOTE:** Make sure that threads are clean and apply thread sealant to pipe threads and fittings.

1. Install oil fill plug (113A), oil drain plug (408A), sight glass (319), sight oiler plug (408J), four oil mist connection plugs (408H), or grease fittings (193) and grease relief plugs (113), and oil cooler inlet and outlet plugs or oil cooler (408L, 408M) in bearing frame (228A) (Fig. 120).

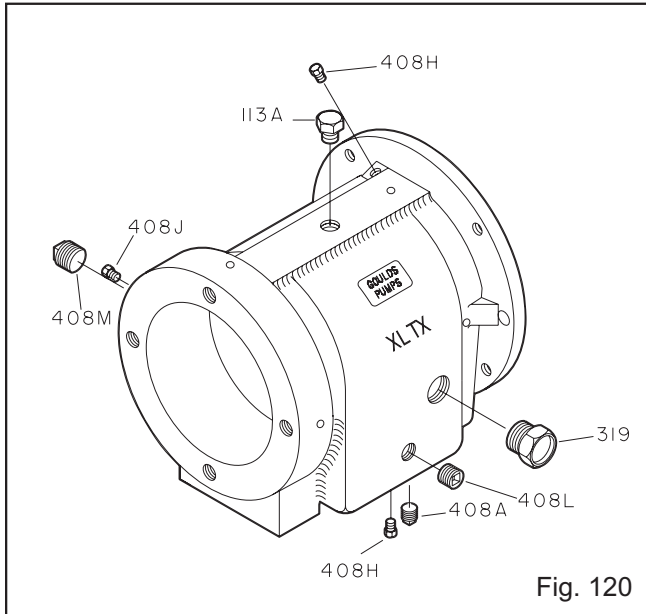

Fig. 120

2. Install outboard bearing (112A) on shaft (122) (Fig. 121).

**NOTE:** Regreaseable bearing has a single shield. The outboard bearing is installed with shield toward impeller.

**NOTE:** There are several methods used to install bearings. The recommended method is to use an induction heater that heats as well as demagnetizes the bearings.



### WARNING

Wear insulated gloves when using a bearing heater. Bearings will get hot and can cause physical injury.



### WARNING

Shaft (122) may be heavy. Use care when handling.

3. Place lockwasher (382) on shaft (122). Place tang of lockwasher in keyway of shaft.
4. Thread locknut (136) onto shaft (122). Tighten locknut until snug. Bend any tang of lockwasher (382) into a slot of locknut.

**NOTE:** Tighten locknut if necessary to align the closest tab of lockwasher with slot on locknut.

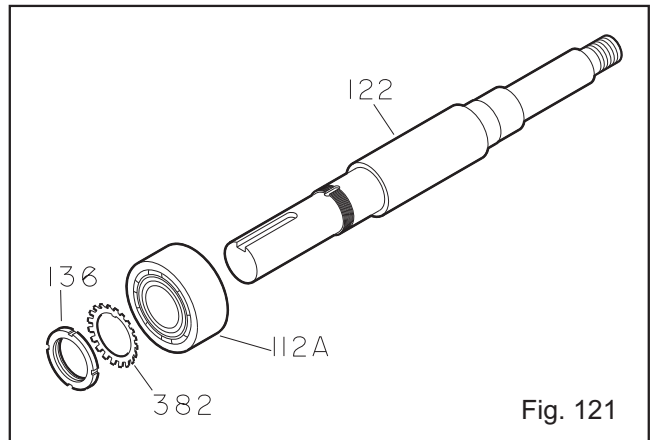

Fig. 121

5. Coat outside of outboard bearing (112A) and bore of bearing housing (134) with oil.
6. Install bearing housing (134) onto shaft/bearing assembly (Fig. 122).

**NOTE:** Do not force assembly together.

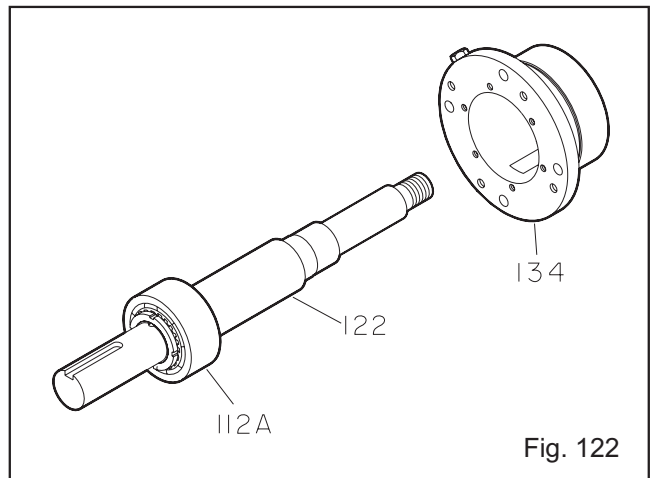

Fig. 122

7. Install gasket (360C), end cover (109A), bolts (371C). Refer to Table 9 for bolt torque values. Check shaft for free turning (Fig. 123).

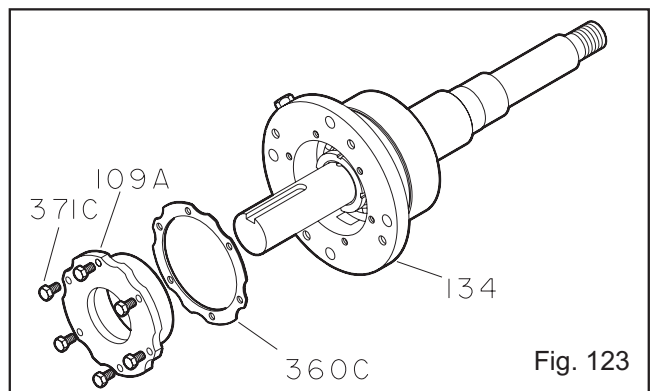

Fig. 123

- Install inboard bearing (168A) on shaft (122) (Fig. 124).

**NOTE:** Refer to Appendix VII-1 for detailed outboard bearing installation instructions.

**NOTE:** Regreaseable bearing has a single shield. The inboard bearing is installed with shield away from impeller.

**NOTE:** There are several methods used to install bearings, The recommended method is to use an induction heater that heats as well as demagnetizes the bearings.



### WARNING

Wear insulated gloves when using a bearing heater. Bearings will get hot and can cause physical injury.

**NOTE:** Coat internal surfaces of bearings with lubricant to be used in service.

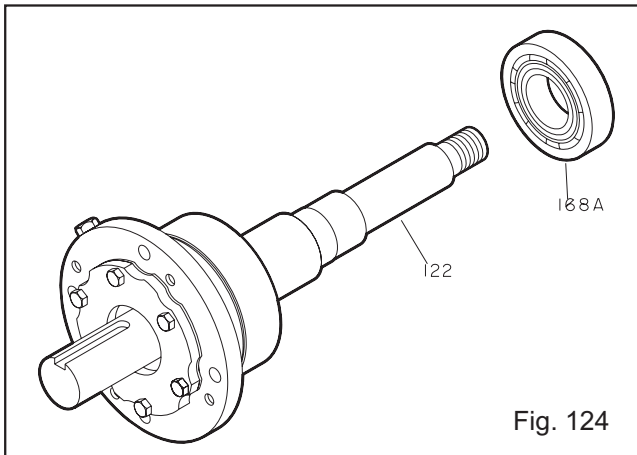

Fig. 124

- Install new O-ring (496) (Fig. 125).
- Install outboard labyrinth oil seal (332A) into end cover (109A). It is an O-ring fit. Position the labyrinth seal drain slots at the bottom 6 o'clock position (Fig. 125).

**NOTE:** See Appendix IV or VIII for further instructions on Labyrinth Seal installation.

**NOTE:** Make sure the keyway edges are free of burrs.

**NOTE:** Cover the keyway lengthwise with a piece of electrical tape prior to installing the labyrinth seal. This will protect the O-rings.

- Coat outside of bearing housing (134) with oil.
- Coat all internal surfaces of bearing frame (228A) with oil.

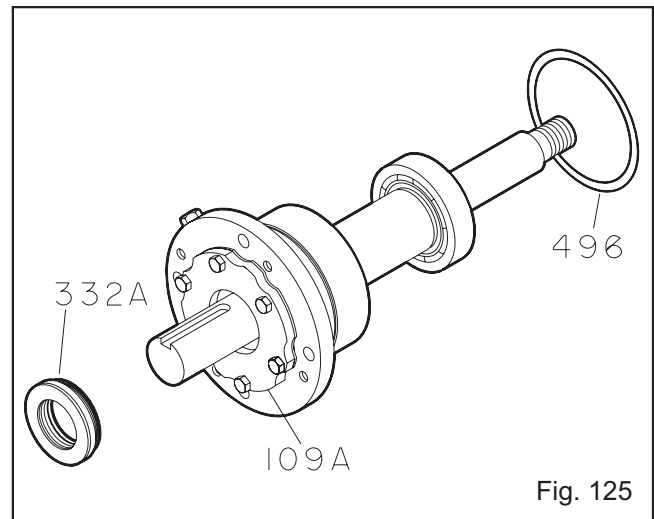

Fig. 125

- Install shaft assembly into frame (228A), making sure to leave approximately 0.125 in. (3.175 mm) clearance between the face of the bearing housing and bearing frame. Check shaft for free turning (Fig. 126).
- Install clamping bolts (370C) into bearing housing (134). Hand tighten.
- Install jacking bolts (370D) with locking nuts (423) into housing (134). Hand tighten.
- Attach bearing frame foot (241) with bolts (370F). Hand tighten.

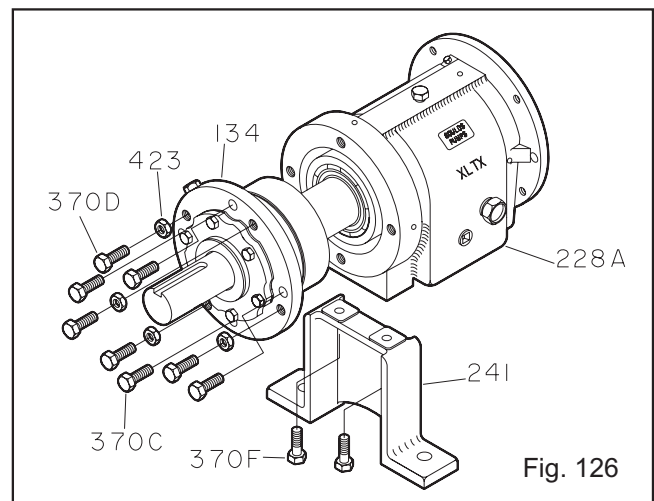

Fig. 126

## STX, MTX with Duplex Bearings

1. Install the oil fill plug (113A), oil drain plug (408A), sight window (319), sight oiler plug (408J), four oil mist connection plugs (408H), or grease fittings (193) and grease relief plugs (113), and oil cooler inlet and outlet plugs or oil cooler (408L, 408M) in bearing frame (228) (Fig. 127).
2. Attach bearing frame foot (241) with bolts (370F). Hand tighten (Fig. 127).

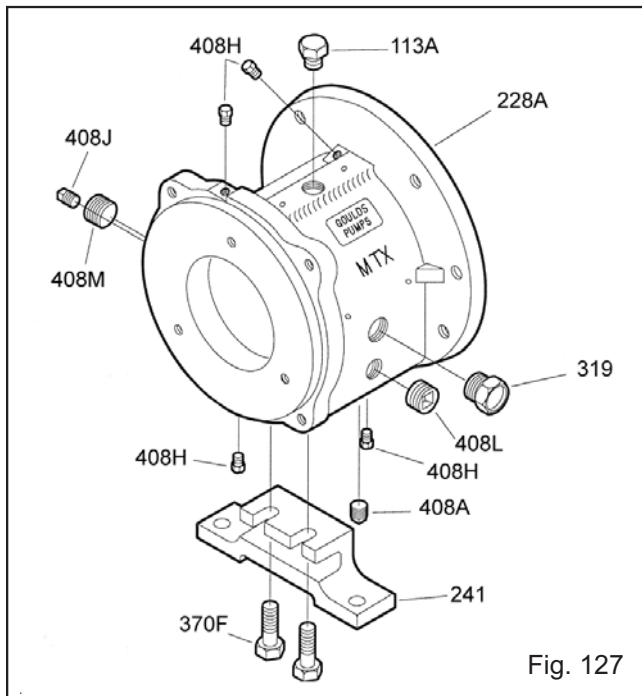

Fig. 127

**NOTE:** There are several methods used to install bearings. The recommended method is to use an induction heater that heats as well as demagnetizes the bearings.



### WARNING

**Wear insulated gloves when using a bearing heater. Bearings will get hot and can cause physical injury.**

3. Install outboard bearings (112A) on shaft (122).

**NOTE:** Refer to Appendix VII-2 for detailed outboard bearing installation instructions.



### CAUTION

**Duplex bearings are mounted back to back. Make sure orientation of bearings is correct.**

4. Place lockwasher (382) on shaft (122). Place tang of lockwasher in keyway of shaft (Fig. 128).

5. Thread locknut (136) onto shaft (122). Tighten locknut until snug. Bend any tang of lockwasher (382) into a slot of locknut.

**NOTE:** Tighten locknut if necessary to align the closest tab of lockwasher with slot on locknut.

6. Place bearing clamp ring (253B) over shaft (122). Note orientation.
7. Install inboard bearing (168A) on shaft (122).

**NOTE:** Regreaseable bearing has a single shield. The inboard bearing is installed with shield away from impeller.

**NOTE:** Coat internal surfaces of bearings with lubricant to be used in service.

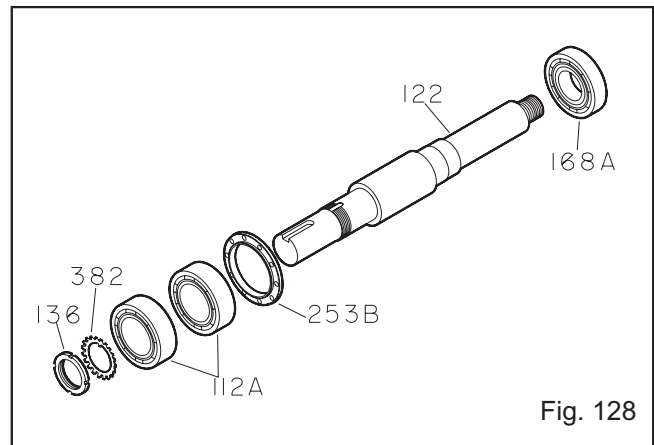

Fig. 128

8. Coat outside of outboard bearing (112A) and bore of bearing housing (134) with oil.
9. Lower shaft/bearing assembly into bearing housing (134) (Fig. 129).

**NOTE:** Do not force assembly together.

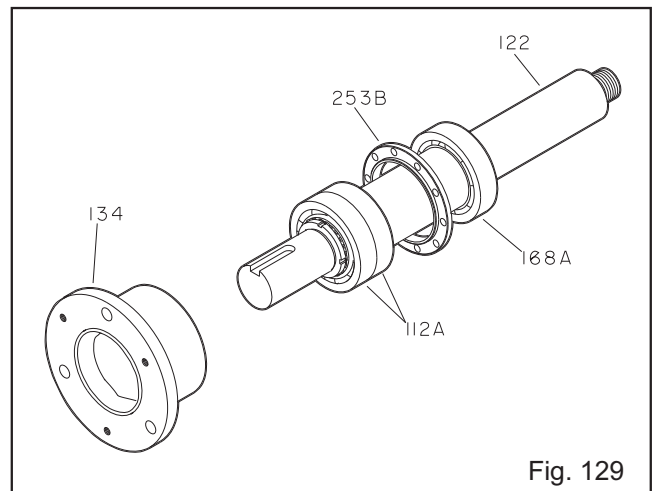

Fig. 129

10. Install clamp ring (253B) with bolts (236A). Tighten bolts in a crisscross pattern. Check shaft for free turning. Refer to *Table 9* for bolt torque values (Fig. 130).
11. Install new O-ring (496).
12. Install outboard labyrinth oil seal (332A) into bearing housing (134). It is an O-ring fit. Position the labyrinth seal drain slots at the bottom 6 o'clock position (Fig. 130).

**NOTE:** See Appendix IV or VIII for further instructions on Labyrinth Seal installation.

**NOTE:** Make sure the keyway edges are free of burrs.

**NOTE:** Cover the keyway lengthwise with a piece of electrical tape prior to installing the labyrinth seal. This will protect the O-rings.

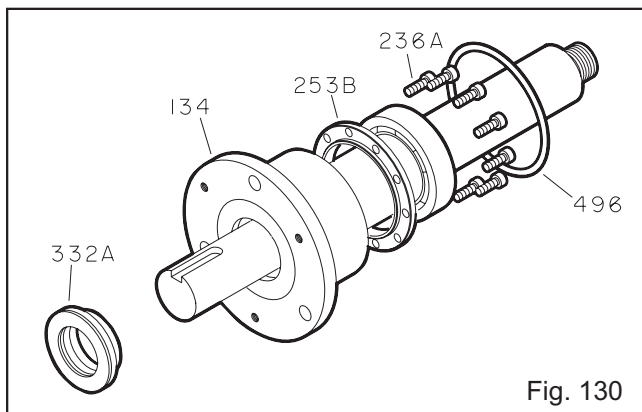

Fig. 130

13. Coat outside of bearing housing (134) with oil.
14. Coat all internal surfaces of bearing frame (228A) with oil.
15. Install shaft assembly into frame (228A), making sure to leave approximately 0.125 in. (3.175 mm) clearance between the face of the bearing housing and bearing frame. Check shaft for free turning (Fig. 131).

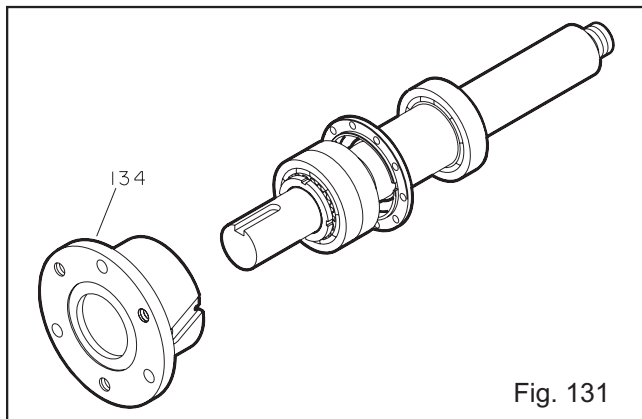

Fig. 131

16. Install clamping bolts (370C) into bearing housing (134A). Hand tighten.
17. Install jacking bolts (370D) with locking nuts (423) into housing (134A). Hand tighten.

## XLT-X, X17 with Duplex Bearings

**NOTE:** Make sure that threads are clean and apply thread sealant to pipe threads and fittings.

1. Install the oil fill plug (113A), oil drain plug (408A), sight window (319), sight oiler plug (408J), four oil mist connection plugs (408H), or grease fittings (193) and grease relief plugs (113), and oil cooler inlet and outlet plugs or oil cooler (408L, 408M) in bearing frame (228) (Fig. 132).

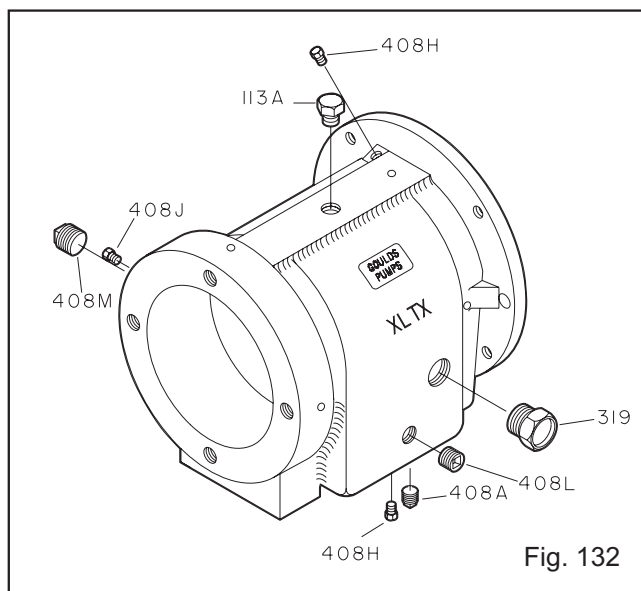

Fig. 132

2. Install outboard bearings (112A) on shaft (122) (Fig. 133).

**NOTE:** Refer to Appendix VII-2 for detailed outboard bearing installation instructions.

**NOTE:** There are several methods used to install bearings. The recommended method is to use an induction heater that heats as well as demagnetizes the bearings.



### WARNING

Wear insulated gloves when using a bearing heater. Bearings will get hot and can cause physical injury.



### CAUTION

Duplex bearings are mounted back to back. Make sure bearing orientation is correct.

- Place lockwasher (382) on shaft (122). Place tang of lockwasher in keyway of shaft.
- Thread locknut (136) onto shaft (122). Tighten locknut until snug. Bend any tang of lockwasher (382) into a slot of locknut.

**NOTE: Tighten locknut if necessary to align the closest tab of lockwasher with slot on locknut.**

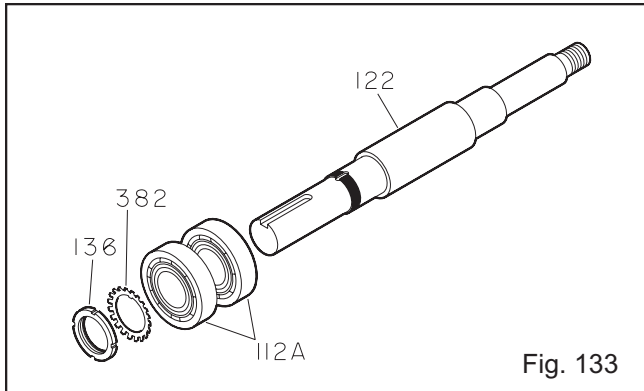

- Coat outside of outboard bearing (112A) and bore of bearing housing (134) with oil.
- Install bearing housing (134) onto shaft/bearing assembly (Fig. 134).

**NOTE: Do not force assembly together.**

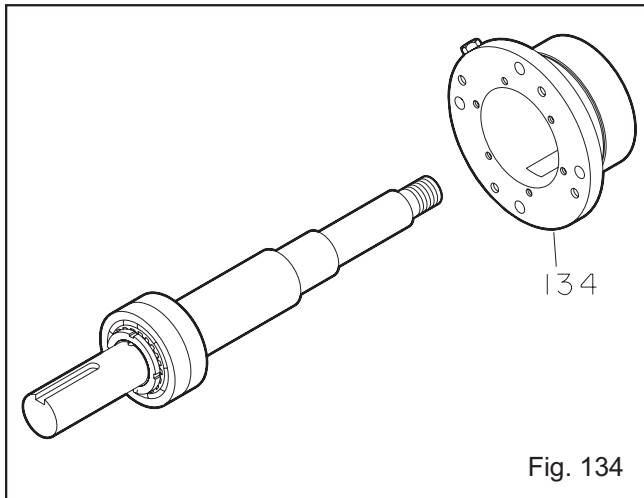

- Install gasket (360C), end cover (109A), and bolts (371C). Refer to *Table 9* for bolt torque values. Check shaft for free turning (Fig. 135).

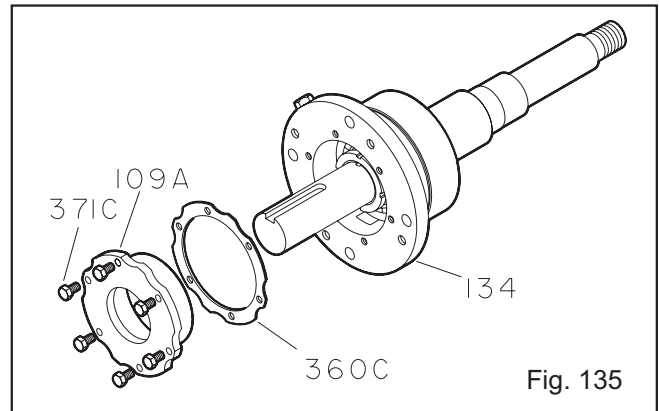

- Install inboard bearing (168A) on shaft (122) (Fig. 136).

**NOTE: Regreaseable bearing has a single shield. The inboard bearing is installed with shield away from impeller.**

**NOTE: There are several methods used to install bearings. The recommended method is to use an induction heater that heats as well as demagnetizes the bearings.**



## WARNING

**Wear insulated gloves when using a bearing heater. Bearings will get hot and can cause physical injury.**

**NOTE: Coat internal surfaces of bearings with lubricant to be used in service.**

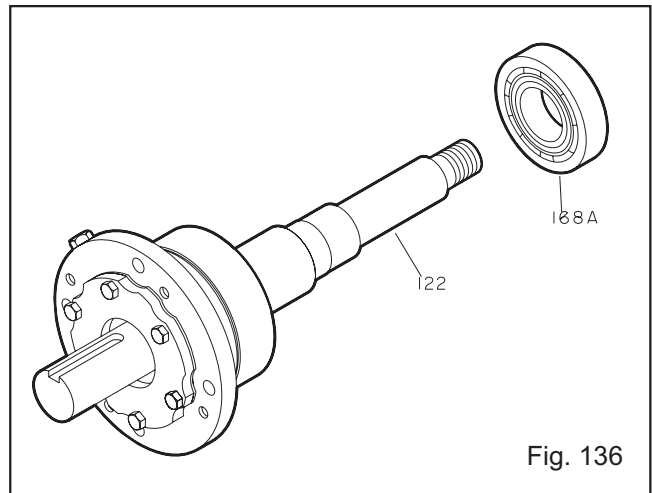

- Install new O-ring (496) (Fig. 137).

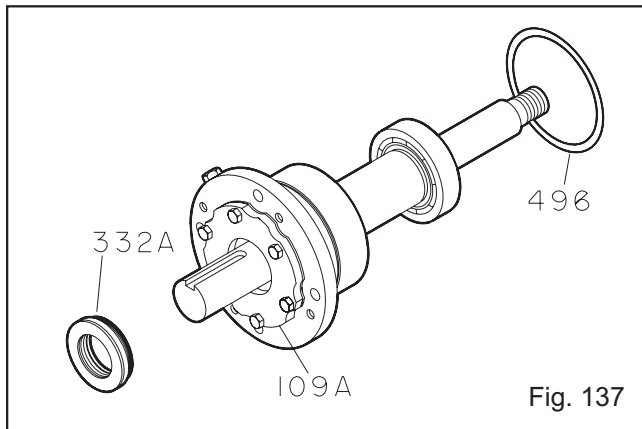

- Install outboard labyrinth oil seal (332A) into end cover (109A). It is an O-ring fit. Position the labyrinth seal drain slots at the bottom 6 o'clock position.

**NOTE: Make sure the keyway edges are free of burrs.**

**NOTE: Cover the keyway lengthwise with a piece of electrical tape prior to installing the labyrinth seal. This will protect the O-rings.**

- Coat outside of bearing housing (134) with oil.
- Coat all internal surfaces of bearing frame (228A) with oil.
- Install shaft assembly into frame (228A), making sure to leave approximately 0.125 in. (3.175 mm) clearance between the face of the bearing housing and bearing frame. Check shaft for free turning (Fig. 138).

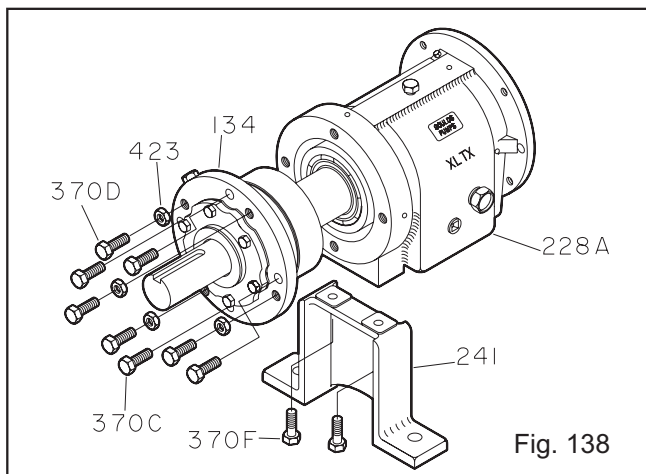

- Install clamping bolts (370C) into bearing housing (134). Hand tighten.
- Install jacking bolts (370D) with locking nuts (423) into housing (134). Hand tighten.

- Attach bearing frame foot (241) with bolts (370F). Hand tighten.

## ALL MODELS

- Support frame assembly in horizontal position.
- Check shaft end play. Move shaft forward then backward by hand, noting indicator movement. If total indicator reading is greater than *Table 10* values, disassemble and determine cause (Fig. 139).

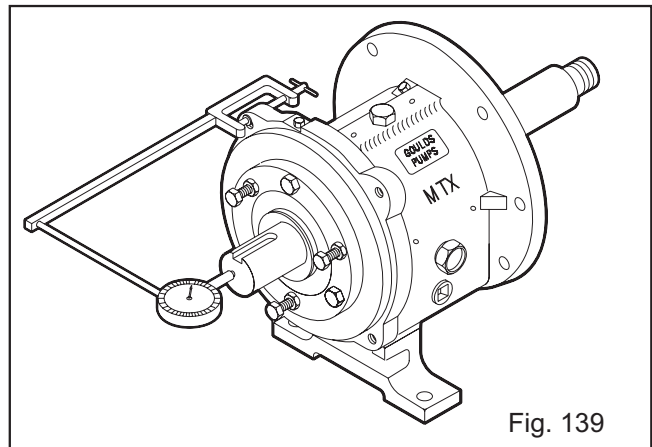

- Check shaft/sleeve runout. Put on shaft sleeve (126) if used, and thread on impeller, hand tight. Rotate shaft 360 degrees. If total indicator reading is greater than .002 in., disassemble and determine cause. Remove impeller and shaft sleeve (Fig. 140).

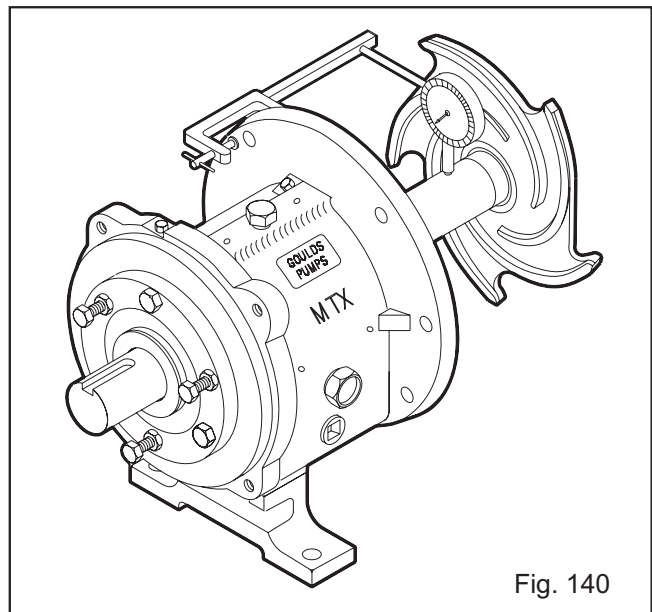

4. Check frame face run out. Rotate shaft so indicator rides along the fit for 360 degrees. If total indicator reading is greater than 0.001 in. (.025 mm) disassemble and determine cause (Fig. 141).

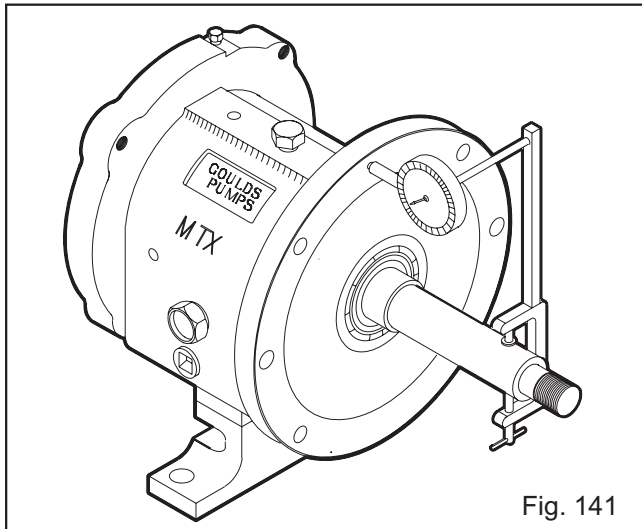

Fig. 141

5. Place manila gasket (360D) on frame (228) (Fig. 142).

**NOTE: The gasket is designed to fit one way only. The dowel pins (469B) may be started in their holes to hold the gasket in place.**

6. Install frame adapter (108), onto frame assembly. Align bolt holes and dowel locations with those on frame (Fig. 142).

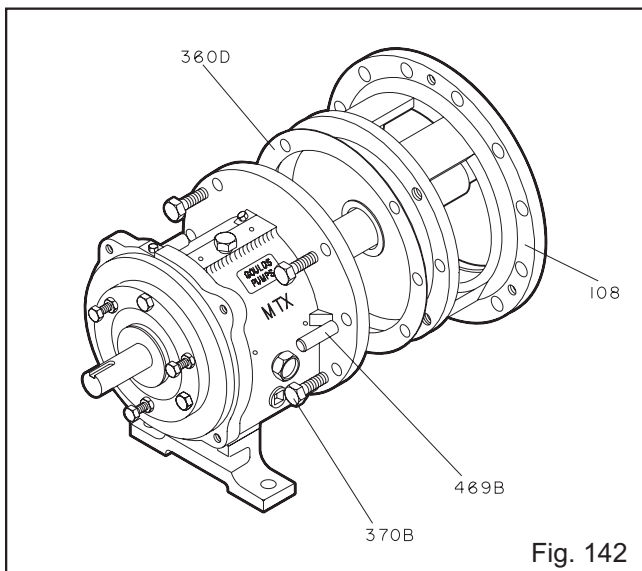

Fig. 142

7. Install dowel pins (469B) and bolts (370B). Tighten bolts to Table 9 torque specifications in a crisscross pattern.

8. Check adapter fits. Rotate shaft through 360 degrees. If total indicator reading is greater than .005 in. (.13 mm), determine the cause and correct before proceeding (Fig. 143).

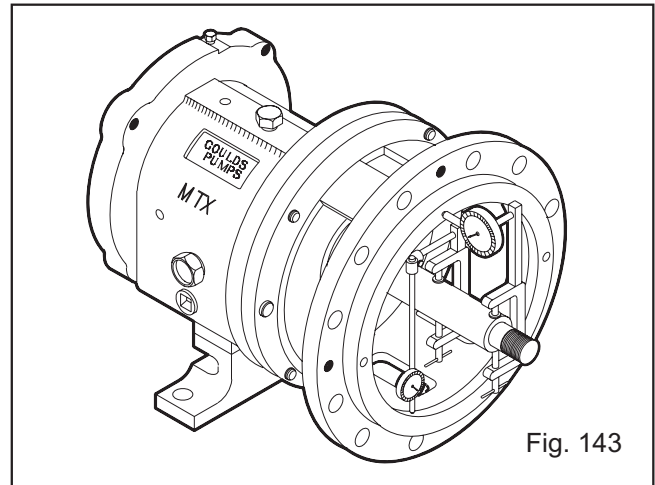

Fig. 143

9. Install inboard labyrinth oil seal (333A) into adapter (108) / bearing frame (228). It is an O-ring fit. Position the labyrinth seal drain slots at the bottom (6 o'clock) position. (Fig. 144).

**NOTE: For detailed labyrinth seal installation instructions, see Appendix IV or VIII, Labyrinth Seal Installation Instructions.**

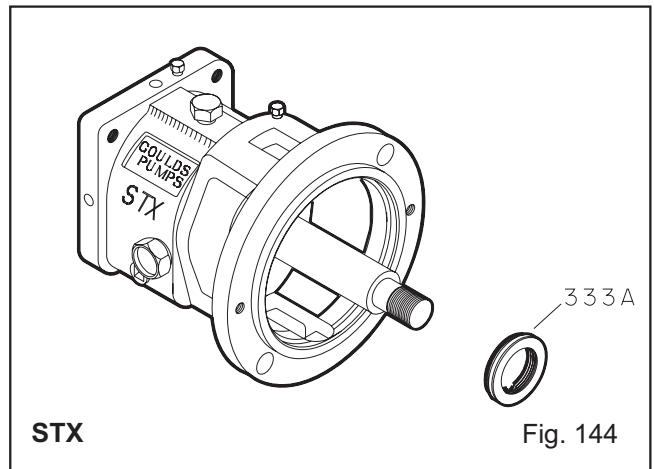
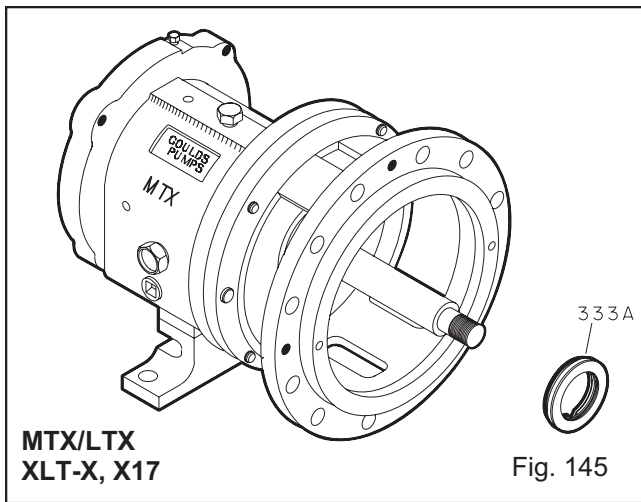
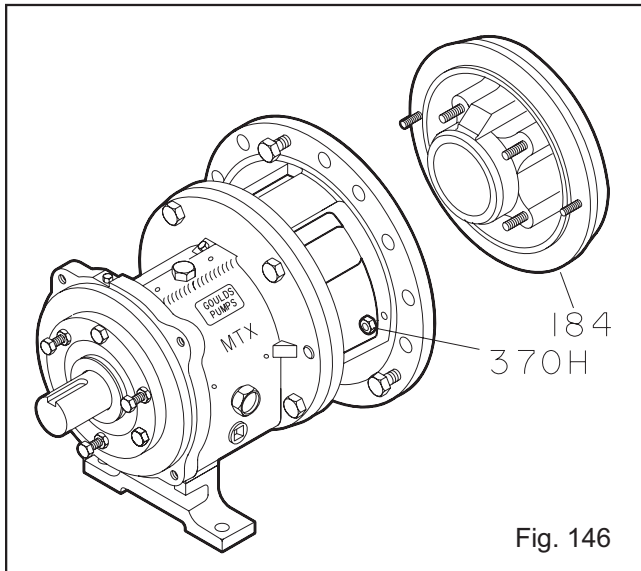

Fig. 144



**Pumps With Mechanical Seals:**

1. Install seal chamber cover or backplate (184) with nuts (370H) (Fig. 146).



2. Check seal chamber cover run-out. Rotate indicator through 360 degrees. If total indicator reading is greater than 0.005 in. (.13 mm), determine cause and correct before proceeding (Fig. 147).

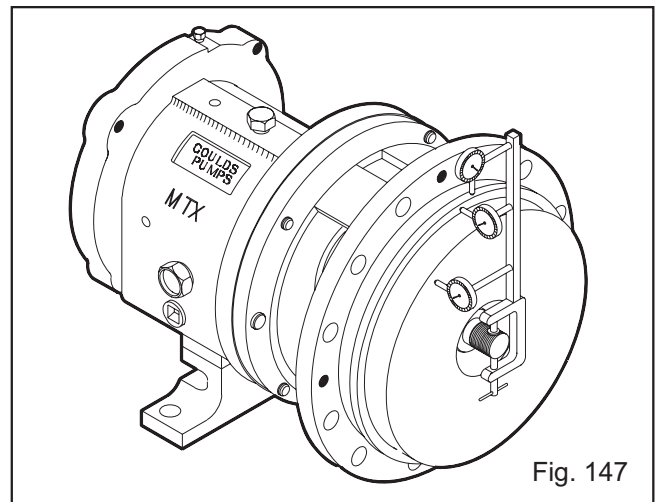

3. Install shaft sleeve (126) if used (Fig. 148).

**NOTE:** If using 3198 with a Teflon® sleeve, the sleeve should already be installed and finish machined.

**NOTE:** Make sure sleeve is fully seated.



**WARNING**

**Wear a heavy set of work gloves when handling impeller (101) as sharp edges may cause physical injury.**

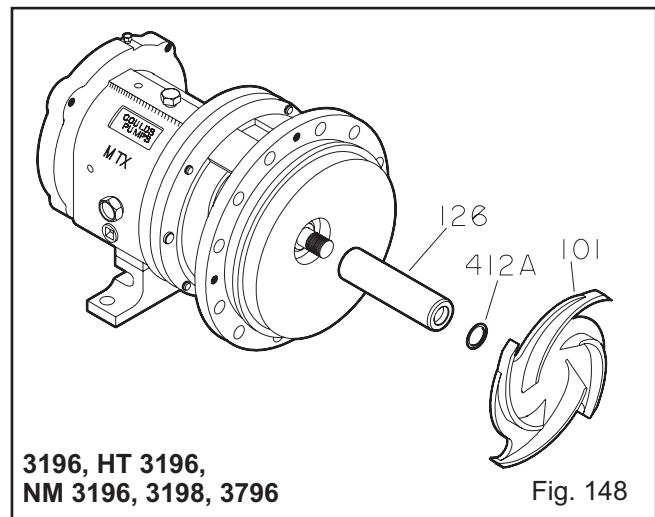

4. STX, MTX, LTX - Install impeller (101) with O-ring (412A).



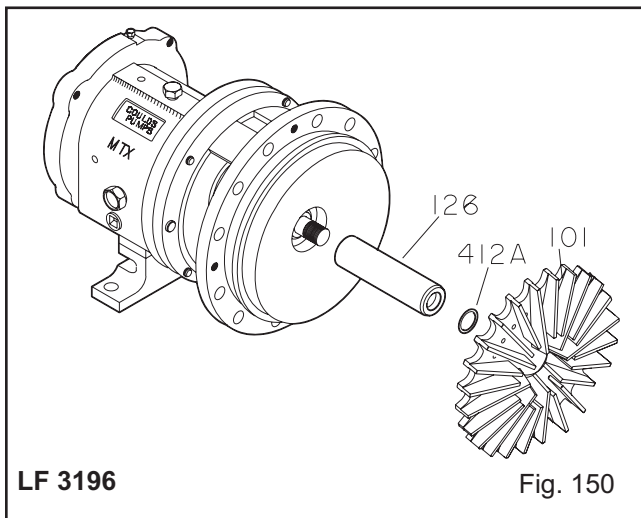
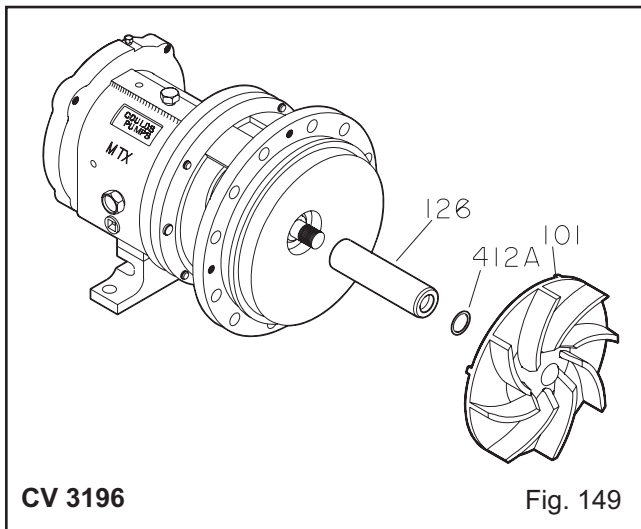

**XLT-X & X17** - Install the impeller (101) without the O-ring (412A) and Teflon® washer (428D) on plug (458Y).

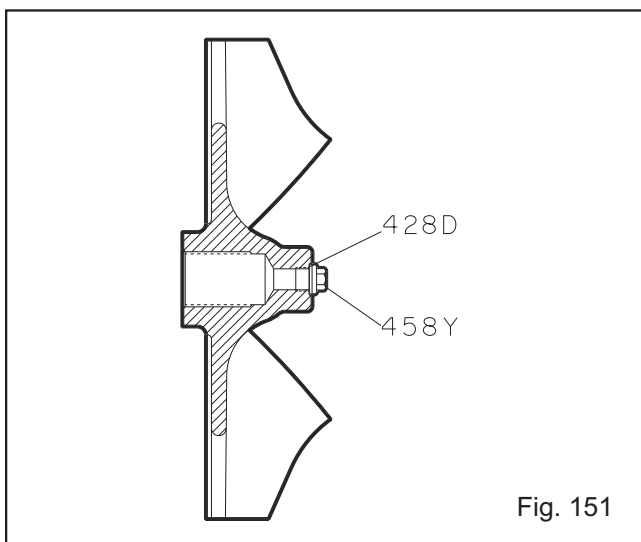

- Put shaft wrench and coupling key on shaft. When impeller (101) makes firm contact with sleeve (126), raise shaft wrench (counterclockwise, viewed from impeller end of shaft) off bench and slam it down (clockwise, viewed from impeller end of shaft). A few sharp raps will tighten impeller (101) properly (Fig. 152).

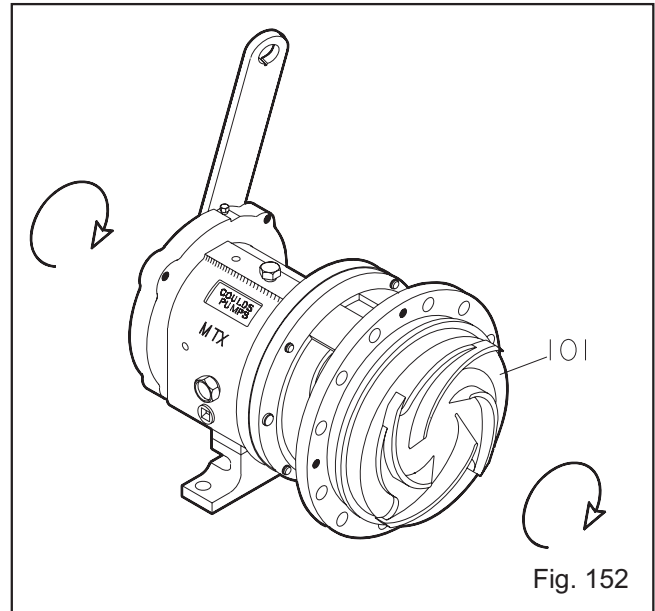

- Loosen clamp bolts (370C), and jacking bolts (370D). Measure gap between impeller (101) and seal chamber/stuffing box cover (184) with a feeler gauge. When 0.030 in. clearance is reached, tighten clamp bolts (370C), jacking bolts (370D), and locking nuts (423) (Fig. 153)

**NOTE:** This approximates the impeller position when set at 0.015 in. (.38 mm) from casing. Final impeller adjustment must be made after installation into casing.

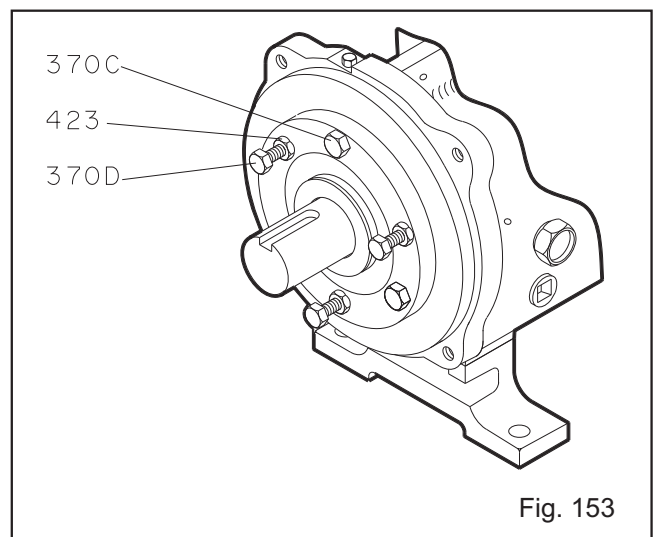

**6**

7. Check impeller (101) runout. Check vane tip to vane tip. If total indicator reading is greater than 0.005 in. (.13 mm), determine cause and correct before proceeding (Fig. 154).

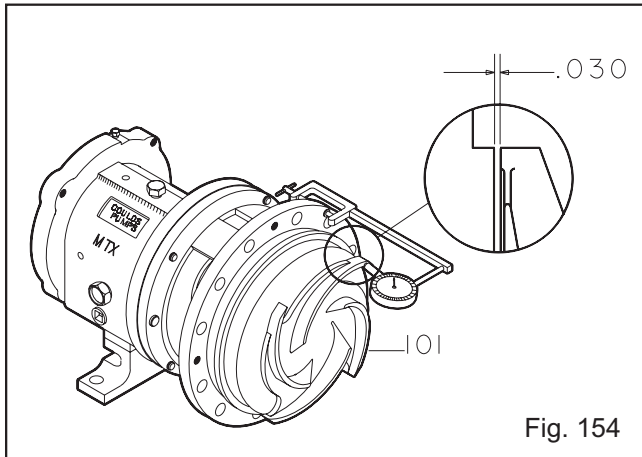

Fig. 154

**NOTE: The face of the CV 3196 impeller is not machined. Checking the face runout on the CV 3196 impeller is not required.**

8. Blue the shaft sleeve (126) or shaft (122) if no sleeve is used. Scribe a mark at gland gasket face of seal chamber/stuffing box cover (184). This will be the datum for installation of mechanical seal (Fig. 155).

**NOTE: The mechanical seal reference dimension for the NM 3196 and the 3198 is based on the gland seat face of the backplate.**

**NOTE: If installing a cartridge mechanical seal, the shaft or sleeve does not need to be marked. The seal is self setting.**

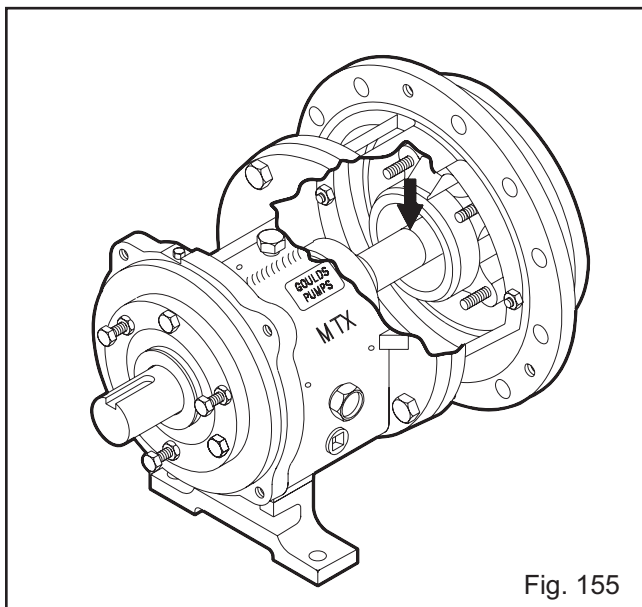

Fig. 155

9. Remove the impeller (101), and shaft sleeve (126) if used.

**NOTE: Do not remove a Teflon® sleeve from a knurled 3198 shaft.**

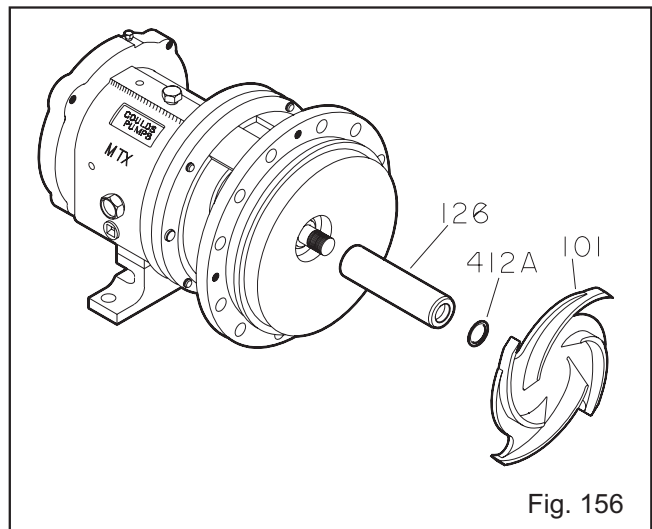

Fig. 156

10. Remove the seal chamber cover or the backplate (184).

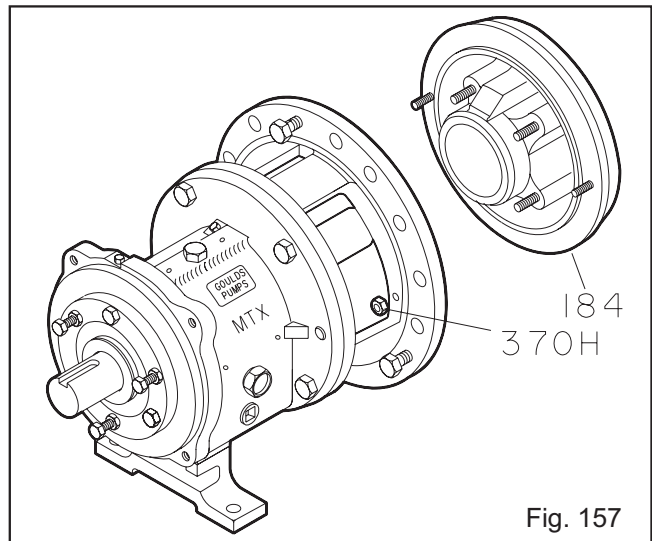

Fig. 157

**For inside mounted seals:**

11. Install stationary seat into gland (107) per seal manufacturer's instructions.
12. Slide gland (107) with stationary seat over shaft, up to adapter face (Fig. 158).

13. Install mechanical seal on shaft (122) or shaft sleeve (126) per seal manufacturer's instructions. Install shaft sleeve (126) if used (with seal).

**NOTE: Anti-galling compound can be applied to the sleeve bore to aid in disassembly.**

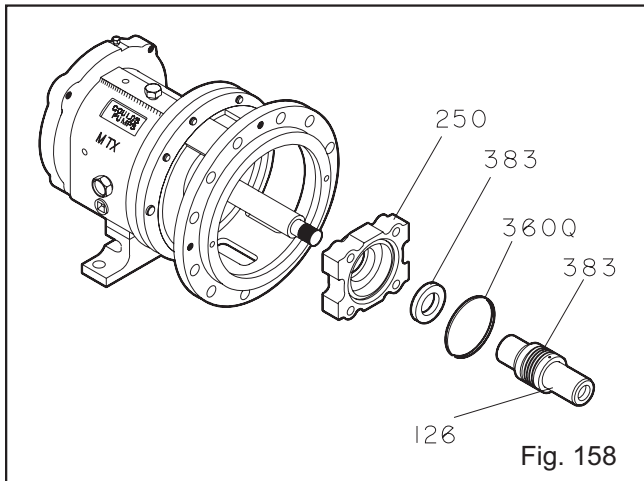

Fig. 158

14. Install seal chamber cover (184) with nuts (370H) (Fig. 159).

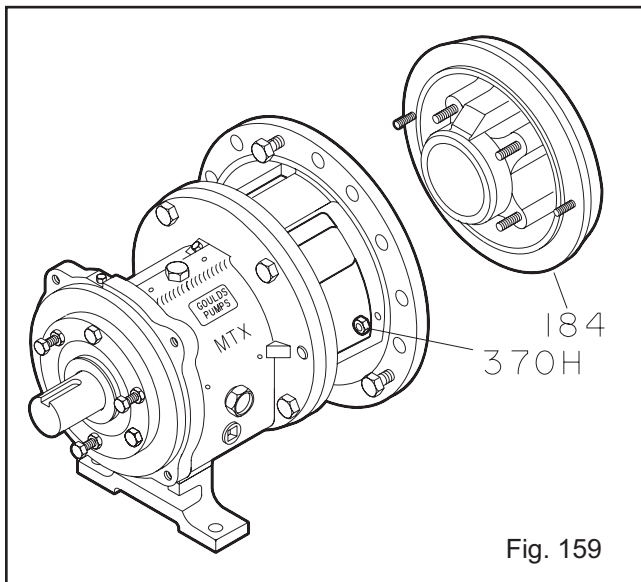

Fig. 159



**WARNING**

**Wear a heavy set of work gloves when handling impeller (101) as sharp edges may cause physical injury.**

15. Install impeller (101) with new O-ring (412A). Put shaft wrench and coupling key on shaft. When impeller (101) makes firm contact with sleeve (126), raise shaft wrench (counterclockwise when viewed from impeller end of shaft) off bench and slam it down (clockwise when viewed from impeller end of shaft). A few sharp raps will tighten impeller (101) properly (Fig. 160).

**NOTE: Be sure to use a properly balanced impeller.**

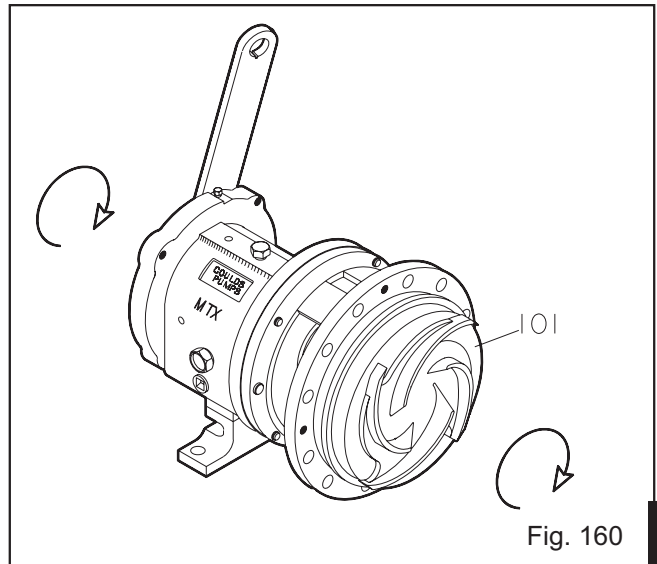

Fig. 160

**6**

16. Install gland (107) with nuts (355) (Fig. 161).

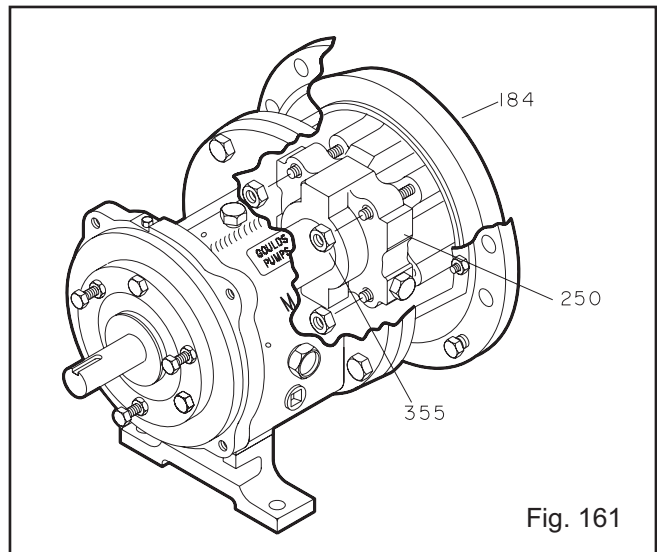
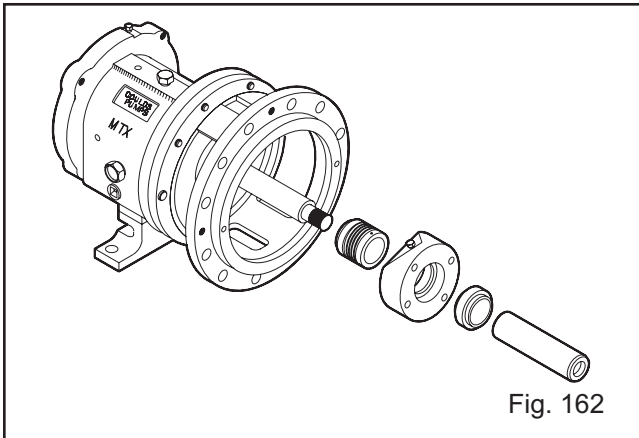

Fig. 161

**For outside mounted seals:**

11. Install the mechanical seal on the shaft (122) or sleeve, if used (126) per the seal manufacturer's instructions. Install the sleeve with the seal, if used.
12. Slide gland and then stationary seat, with gaskets, on the shaft or sleeve (Fig. 162).



13. Install the seal chamber or backplate (184) with hex nuts (370H). Be sure that the gland studs line up with the holes in the gland (Fig. 163).

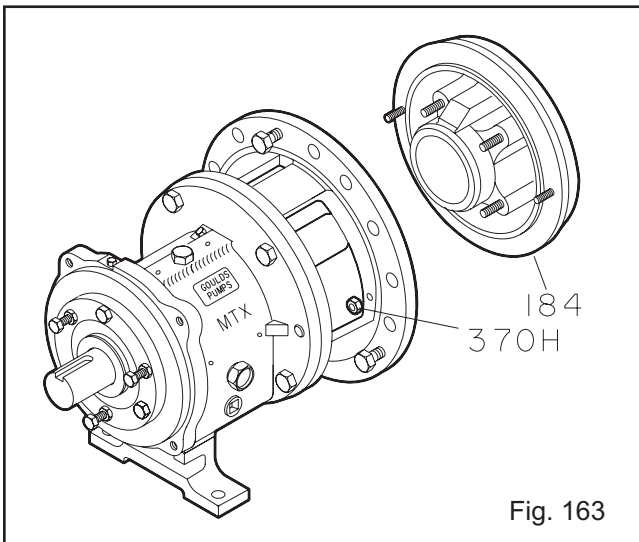

14. Install the impeller (101) with a new o-ring (412A). Put the shaft wrench and coupling key on the shaft. When the impeller makes firm contact with the sleeve, raise the shaft wrench (counter-clockwise when viewed from the impeller end of the shaft) off the bench and slam it down (clockwise when viewed from the impeller end of the shaft). A few sharp raps will tighten the impeller properly (Fig. 164).

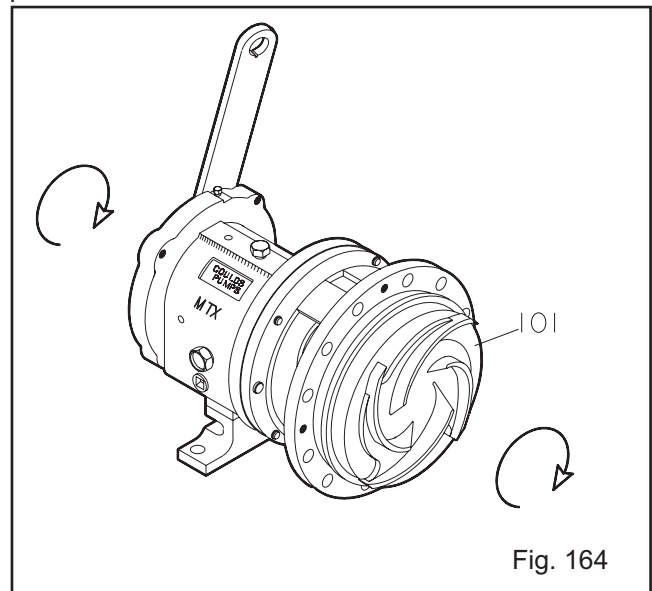

**NOTE:** Be sure to use a properly balanced impeller.

15. Install the gland (107) with hex nuts (355).

**Pumps With Packing:**

1. Install stuffing box cover (184) with nuts (370H) (Fig 165).

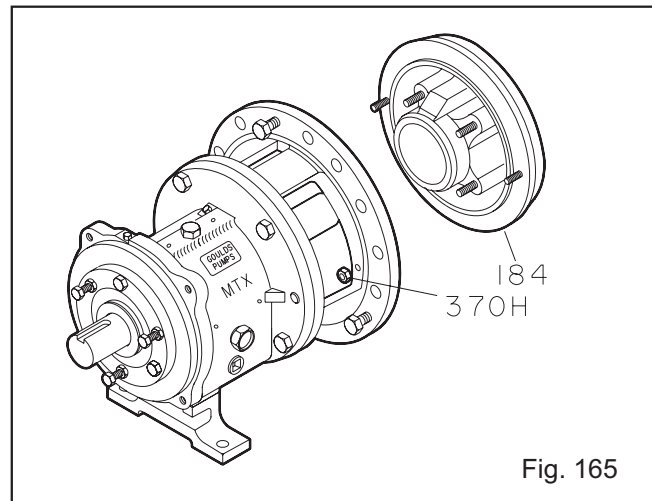

2. Check stuffing box cover run-out. Rotate indicator through 360 degrees. Total indicator reading greater than 0.005 in. (.13 mm) indicates a problem (Fig. 166).

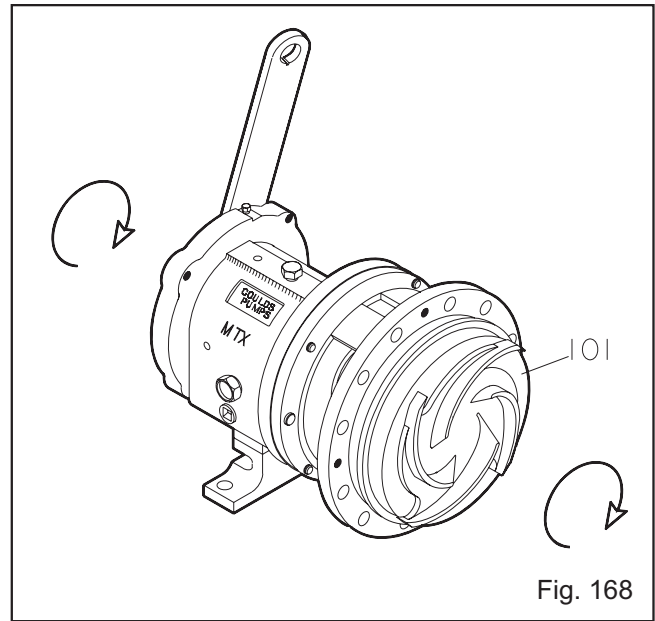
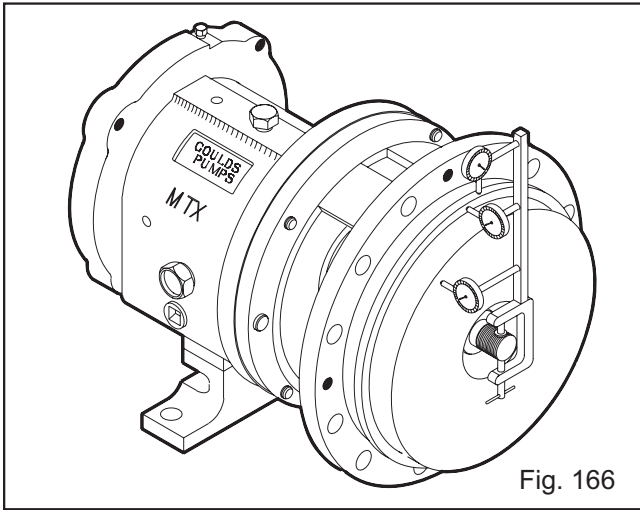

3. Install shaft sleeve (126) (Fig. 167).

**NOTE:** Anti-galling compound can be applied to the sleeve bore to aid in disassembly.

**NOTE:** Make sure sleeve is fully seated.



### WARNING

Wear a heavy set of work gloves when handling impeller (101) as sharp edges may cause injury.

5. Loosen clamp bolts (370C), and jacking bolts (370D) (Fig. 169). Measure gap between impeller (101) and seal chamber/stuffing box cover (184) with a feeler gauge. When 0.030 in. (.76 mm) clearance is reached, tighten clamp bolts (370C), jacking bolts (370D), and locking nuts (423) (Fig. 169).

**NOTE:** This approximates the impeller position when set at 0.015 in. (.38 mm) from casing.

6

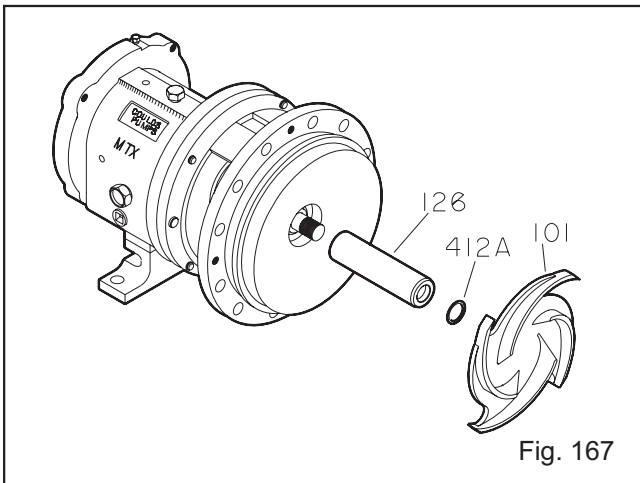

4. Install impeller (101) with O-ring (412A). Put shaft wrench and coupling key on shaft. When impeller (101) makes firm contact with sleeve (126), raise shaft wrench (counterclockwise when viewed from impeller end of shaft) off bench and slam it down (clockwise when viewed from impeller end of shaft). A few sharp raps will tighten impeller properly (Fig. 168).

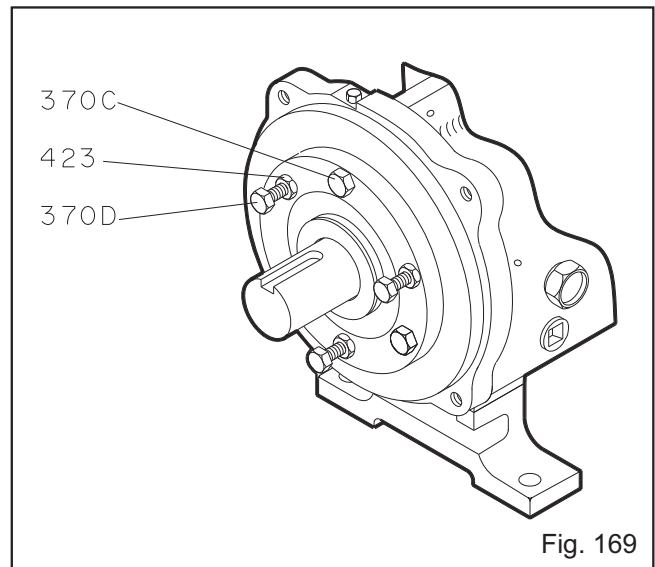

6. Check impeller runout. Check vane tip to vane tip. Total indicator reading greater than 0.005 in. (.13 mm) indicates a problem (Fig. 170).

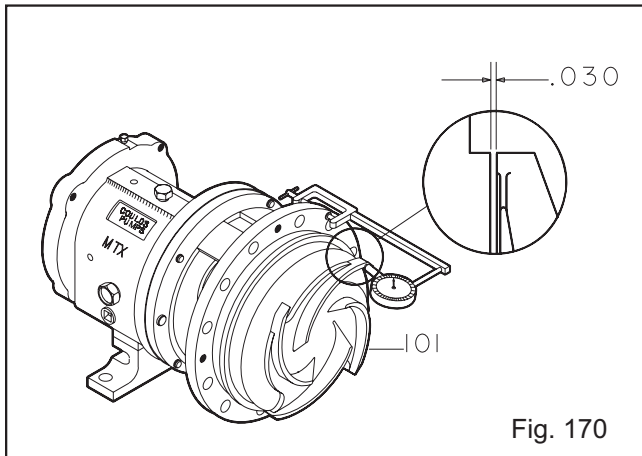

Fig. 170

**NOTE: The face of the CV 3196 impeller is not machined. Checking the face runout on the CV 3196 impeller is not required.**

7. Install packing and gland according to Section 4, Operation.

**Pumps With Dynamic Seals:  
(3196, CV 3196, LF 3196 only)**

1. Place backplate (444) flat side down on the bench (Fig. 171).

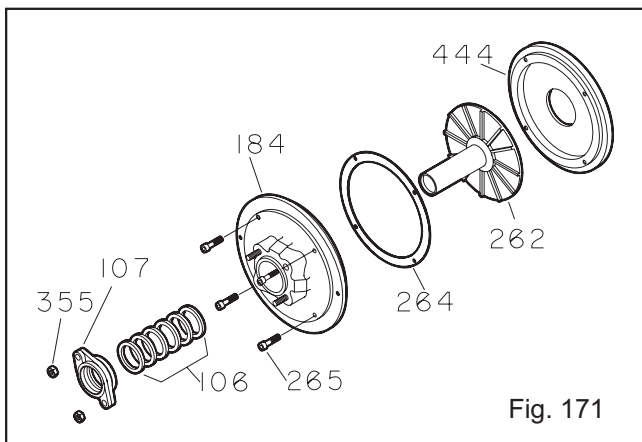

Fig. 171

2. Place repeller (262) in backplate (444), sleeve side up.
3. Place Teflon gasket (264) on backplate (444), lining up holes.
4. Place stuffing box cover (184) on backplate (444), lining up holes.

5. Install four (4) socket head cap screws (265), tighten securely.
6. Install new sealing element into gland.
7. Install gasket (360Q) and gland (107) on stuffing box cover (184). Install nuts (355).
8. Install dynamic seal assembly. Install nuts (370H) (Fig. 172).

**NOTE: Anti-galling compound can be applied to the sleeve bore to aid in disassembly.**

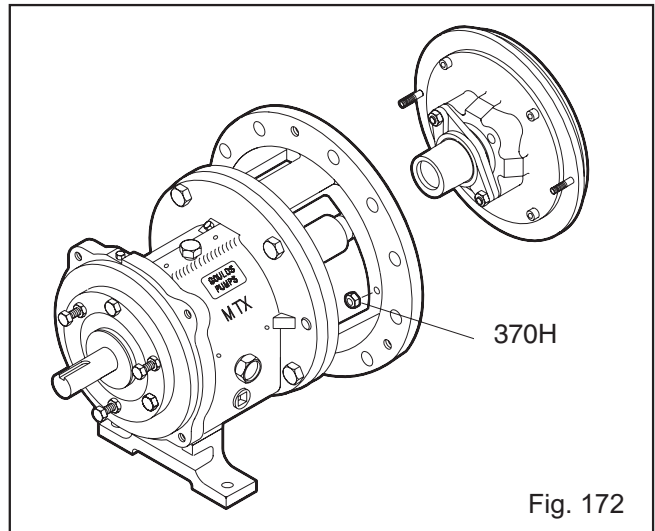

Fig. 172

9. Check stuffing box cover run-out. Rotate indicator through all 360 degrees. Total indicator reading greater than 0.005 in. indicates a problem (Fig. 173).

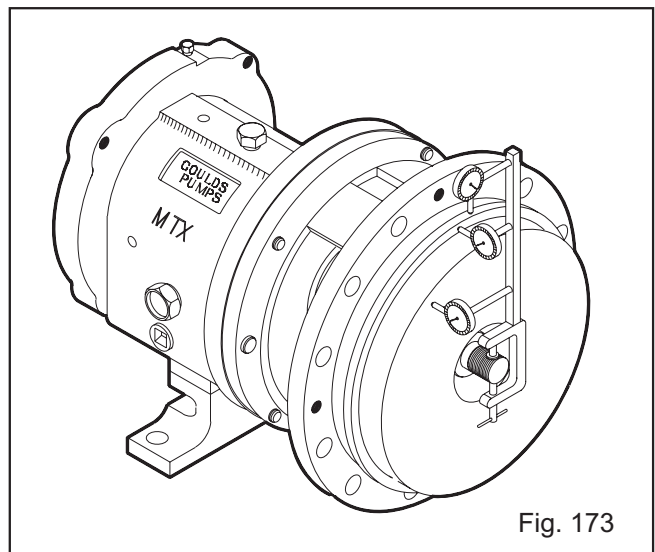

Fig. 173

# ALL MODELS STX, MTX, LTX, XLT-X, X17

## Reinstall Back Pull-Out Assembly



### WARNING

*Back pull-out assembly weighs more than 50 lbs. Do not handle unassisted as physical injury may occur.*

1. Clean casing fit and install casing gasket (351) in place on seal chamber/stuffing box cover.
2. Loosen clamping bolts (370C) and jacking bolts (370D) on bearing housing (Fig. 174).

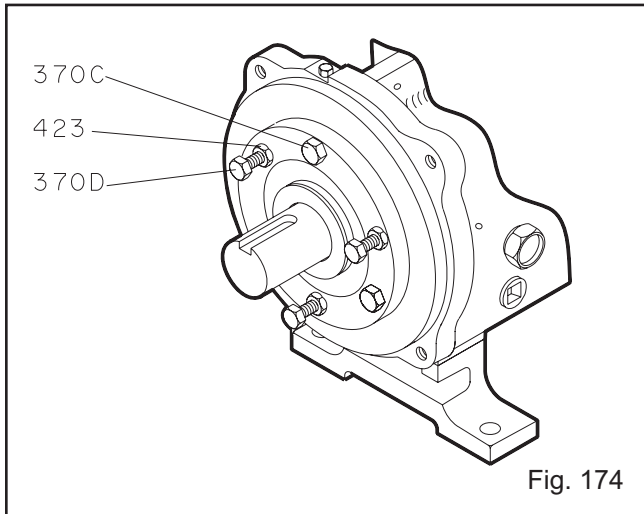

Fig. 174

3. Install back pull-out assembly in casing (Fig. 175, 176).

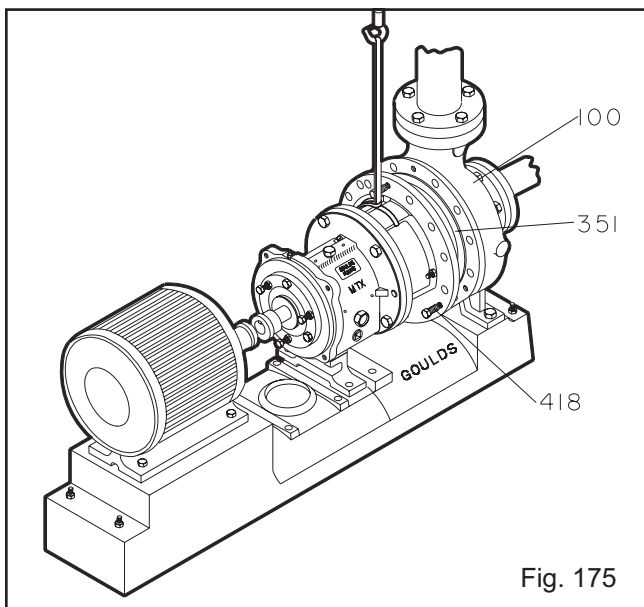

Fig. 175

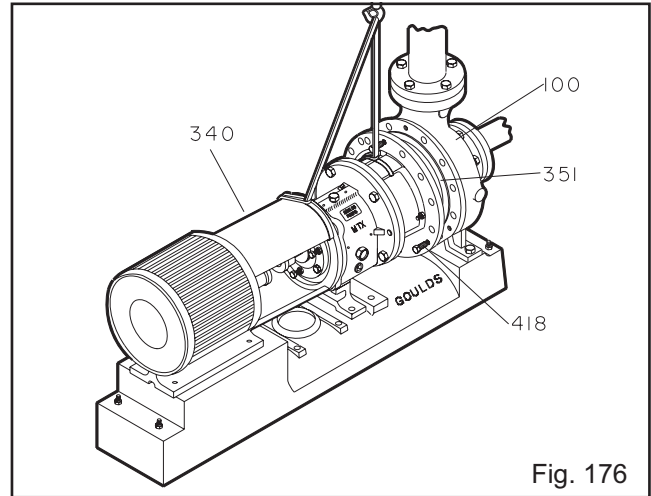

Fig. 176

4. Install casing bolts (370), finger tight. Casing bolts (370) may be coated with anti-galling compound to aid disassembly. Tighten the casing bolts per *Table 9* torque values. Install casing jack screws (418), snug tight (Fig. 177).



### CAUTION

*Do not overtighten casing jack screws (418).*

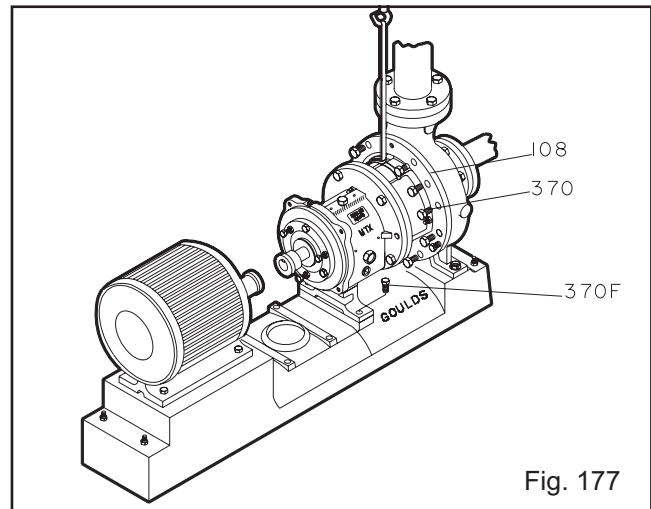

Fig. 177

5. Replace shims under frame foot and tighten frame foot to baseplate. To insure that the proper shim is used, a dial indicator should be mounted to measure distance between top of frame and baseplate. This distance should not change as frame foot bolting is tightened.

6. Check total travel of impeller in casing. With new parts, acceptable range is 0.030 in. (.76 mm) to 0.065 in. (1.65 mm). If outside this range, improper parts or installation or too much pipe strain is present. Determine cause and correct.
7. Adjust impeller clearance according to procedure outlined in the Preventive Maintenance Section.

8. Replace auxiliary piping at this time.
9. Fill pump with proper lubricant. Refer to *Section 5, Preventive Maintenance* for requirements.

**NOTE: For reassembly of the C-Face adapter, see Appendix V.**

## Model HT 3196 Only

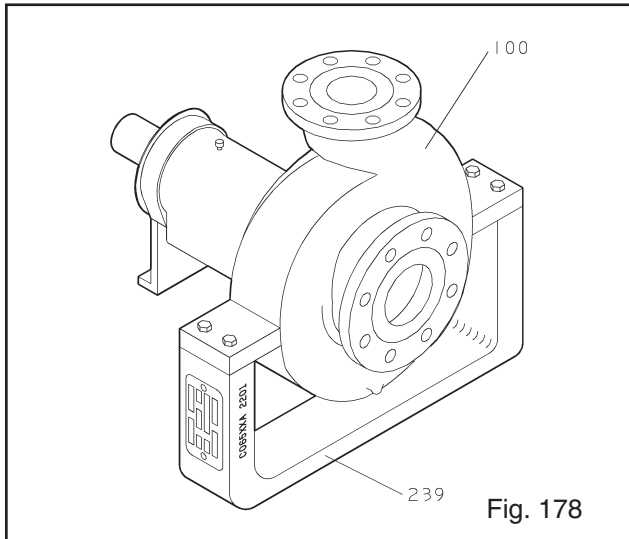

1. Assemble casing support (239) to casing (100) as shown in Fig. 178. The stamped part number on the casing support (239) is located on the left hand side when facing the casing suction.

## POST ASSEMBLY CHECKS



**All checks and procedures listed under Safety, Installation, Operation and Preventive Maintenance sections must be followed.**

After completion of these operations, check if it is possible to rotate shaft easily by hand. If all is proper, continue with pump start-up.



# ASSEMBLY TROUBLESHOOTING

Symptom	Cause	Remedy
Excessive shaft end play.	Bearing internal clearance too great.	Replace bearings with correct type.
	Snap ring loose in bearing housing groove.	Reseat.
Excessive shaft/sleeve runout.	Sleeve worn.	Replace
	Shaft bent.	Replace.
Excessive bearing frame flange runout.	Shaft bent.	Replace
	Bearing frame flange distorted.	Replace.
Excessive frame adapter runout.	Corrosion.	Replace.
	Adapter to frame gasket not seated properly.	Reseat.
Excessive seal chamber/stuffing box cover runout.	Seal chamber/stuffing box cover not properly seated in frame adapter.	
	Corrosion or wear.	Replace.
Excessive impeller vane tip runout.	Bent vane(s).	Replace impeller.

## PARTS LIST WITH MATERIALS

Item	Qty per Pump	Part Name	3196, CV 3196, HT 3196, 3796				
			All D.I.	D.I. w/ 316SS Impeller	All 316SS	Al CD4MCu	All Alloy 20
100	1	Casing	1012				
101	1	Impeller	1013				
105	1	Lantern Ring				Teflon®	
106	1 Set	Stuffing Box Packing				Non-Asbestos Braid	
107	1	Gland—Packed Box		1203			1204
108	1	Frame Adapter				1013	
109C	1 X	Outboard Bearing End Cover				1001	
112A	1	Outboard Bearing				Double row angular contact (duplex pair for LTX)	
113	2	Plug—Grease Relief				2210	
113B	1	Plug—Oil Fill				2210	
122	1	Shaft—Less Sleeve	▲			2229	2230
122	1	Shaft—With Sleeve				2238	
126	1	Shaft Sleeve				2229	2230
134	1	Bearing Housing				1001	
136	1	Bearing Locknut				Steel	
168A	1	Radial Bearing				Single Row Ball	
184	1	Seal Chamber/Stuffing Box Cover	1012	1012	1203	1216	1204
193	2	Grease Fitting				Steel	
228	1	Bearing Frame				STX All Others - 1001	
236A	10	Cap Screw—Bearing Clamp Ring				2210	
241	1	Frame Foot				1001	
248	1	Oil Thrower				2210	
250	1	Gland—Mechanical SEal				Material Varies	
253B	1	Bearing Clamp Ring				2210	
319	1	Sight Glass				Glass/Steel	
332A	1	Outboard Labyrinth Seal w/O-rings				Brass ASTM B505-96	
333A	1	Inboard Labyrinth Seal w/O-rings				Brass ASTM B505-96	
351	1	Casing Gasket				Aramid Fiber w/EPDM	
353	4	Gland Stud				2228	
355	4	Gland Stud Nut				2228	
358	1	Plug—Casing Drain		2210		2229	2230
358Y	1 X	Plug, Impeller			2229		2230
360C	1 X	Gasket—Thrust End Cover				Vellumoid	
360D	1	Gasket—Frame-to-Adapter				Vellumoid	
360Q	1	Gasket—Gland-to-Stuffing Box Cover				Material Varies	
361A	1	Retaining Ring				Steel	
370	★	Bolt—Adapter to Case		2210			2228
370B	4	Bolt—Frame-to-Adapter				2210	
370C	✱	Clamp Bolt —Bearing Housing				2210	
370D	✱	Jack Bolt—Bearing Housing				2210	
370F	2	Bolt—Frame Foot to Frame				2210	
370H	2	Stud—Stuffing Box Cover-to-Adapter				2228	
371C	6 X	Cap Screw-End Cover to Bearing Housing				2210	
382	1	Bearing Lockwasher				Steel	
383	1	Mechanical Seal				Material Varies	
400	1	Coupling Key				2210	
408A	1	Plug—Oil Drane				2210	
408H	4	Plug—Oil Mist Connection				2210	
408J	1	Plug—Oiler				2210	
408L	1	Plug—Oil Cooler Inlet				2210	
408M	1	Plug—Oil Cooler Outlet				2210	
408N	1	Plug—Sight Glass				2210	
418	3	Jack Bolt—Adapter-to-Case				2228	
423	3	Jam Nut—Bearing Housing Jack Bolt				2210	
423B	2	Hex Nut—Stuffing Box Cover to Adapter				2228	
428	1	Gasket, Plug				Teflon®	
458Y	1 X	Plug, Impeller			2229		2230
469B	2	Dowel Pin—Frame-to-Adapter				Steel	
494	1	Tube Element, Finned Cooled				304SS / Copper	
496	1	O-Ring Bearing Housing				Buna N	
412A	1	O-Ring—Impeller				Teflon®	
497F	1	O-Ring—Outboard Labyrinth Rotor				Viton	
497G	1	O-Ring—Outboard Labyrinth Stator				Viton	
497H	1	O-Ring—Inboard Labyrinth Rotor				Viton	
497J	1	O-Ring—Inboard Laybrinth Stator				Viton	
497L	1	O-Ring Internal (inboard)				Viton	
497N	1	O-Ring Internal (outboard)				Viton	
503	1 #	Adapter Ring				1013	
529	1	Lockwasher—Frame Foot-to-Bearing Frame				Steel	
555	1	Tube, Finned Cooling Assembly				304AA / Copper	
555A	1	Tube, Ftg Male (Frame Cooling)				Brass	
555B	2	Connector, Thermocouple (Frame Cooling)				Brass	
555C	2	Elbow, Female (Frame Cooling)				Brass	
555D	1	Conn TC Sealed PWR				Cast Iron	



## MATERIAL CROSS REFERENCE CHART

Material	ITT Goulds Pumps Material Code	ASTM	DIN	ISO	JIS
Cast Iron	1001	A48 CLASS 20			
Ductile Iron	1012	A395 Gr60-40-18			
Ductile Iron	1013	A536 Gr60-42-10			
CD4MCu	1041	A744 CD4MCU			
Monel	1119	A494 GrM-35-1			
316SS	1203	A744 CF-8M	1.4408		G5121 (SC514)
Alloy 20	1204	A744CN-7M	1.4500		
317SS	1209	A744CG-8M	1.4448		
Hastelloy C	1215	A494 CW-6M			
CD4MCu	1216	A744CD4MCU	9.4460		
Hastelloy B	1217	A494 N-7M			
Titanium	1220	B367 GrC-3			
Nickel	1601	A494 GrCZ100			
Monel	2150	B164 UNS N04400			
Nickel	2155	B160 UNS N02200			
Titanium	2156	B348 Gr2			
Carbon Steel	2201	A576 Gr. 1018 and 1020			
Carbon Steel	2210	A108Gr1211			
304SS	2228	A276 Type 304			
316SS	2229	A276 Type 316			
Alloy 20	2230	B473 (N08020)			
317SS	2232	A276			
4150 Steel	2237	A322Gr4150			
4140 Steel	2238	A434Gr4140			
4140 Steel	2239	A193 Gr. B7			
Alloy B-2	2247	B335 (N10665)			
Alloy C-276	2248	B574 (N10276)			
GMP-2000	6929	N/A			
PFA Lined Steel	6944	N/A			
PFA Lined 316SS	6947	N/A			
PFA Lined Ductile Iron	9639	N/A			

### Fasteners/Plugs

Material	ITT Goulds Pumps Material Code	ASTM
Carbon Steel	2210	A307Gr.B.
Stainless Steel	2228	F593Gr1
316 Stainless Steel	2229	F593Gr2

## Model HT 3196 Parts List with Materials of Construction

**(For all other Items refer to the 3196 Parts List with Materials of Construction)**

316SS			Alloy 20		
Item	Part Description	Mat'l Code	Item	Part Description	Mat'l Code
100	Casing	1203	100	Casing	1204
122	Shaft - With Sleeve	2229	122	Shaft - With Sleeve	2229
122	Shaft - Less Sleeve (Optional)	2229	122	Shaft - Less Sleeve (Optional)	2230
239	Support, Casing	2201	239	Support, Casing	2201
351	Gasket, Casing	5175	351	Gasket, Casing	5175
370	Screw, H. Cap Adapter to Casing	2239	370	Screw, H. Cap Adapter to Casing	2239
370Y	Screw, H. Cap Casing to Support	2210	370Y	Screw, H. Cap Casing to Support	2210
412A	O-Ring, Graphoil Impeller		412A	O-Ring, Graphoil Impeller	
437	Lockwasher, Casing to Support	2210	437	Lockwasher, Casing to Support	2210
494	Finned Cooler Tube		494	Finned Cooler Tube	

Hastelloy C			CD4MCu		
Item	Part Description	Mat'l Code	Item	Part Description	Mat'l Code
100	Casing	1215	100	Casing	1216
122	Shaft - With Sleeve	2229	122	Shaft - With Sleeve	2229
122	Shaft - Less Sleeve (Optional)	2248	122	Shaft - Less Sleeve (Optional)	2230
239	Support, Casing	2201	239	Support, Casing	2201
351	Gasket, Casing	5175	351	Gasket, Casing	5175
370	Screw, H. Cap Adapter to Casing	2239	370	Screw, H. Cap Adapter to Casing	2239
370Y	Screw, H. Cap Casing to Support	2210	370Y	Screw, H. Cap Casing to Support	2210
412A	O-Ring, Graphoil Impeller		412A	O-Ring, Graphoil Impeller	
437	Lockwasher, Casing to Support	2210	437	Lockwasher, Casing to Support	2210
494	Finned Cooler Tube		494	Finned Cooler Tube	

# Model 3196 Cross Sectional

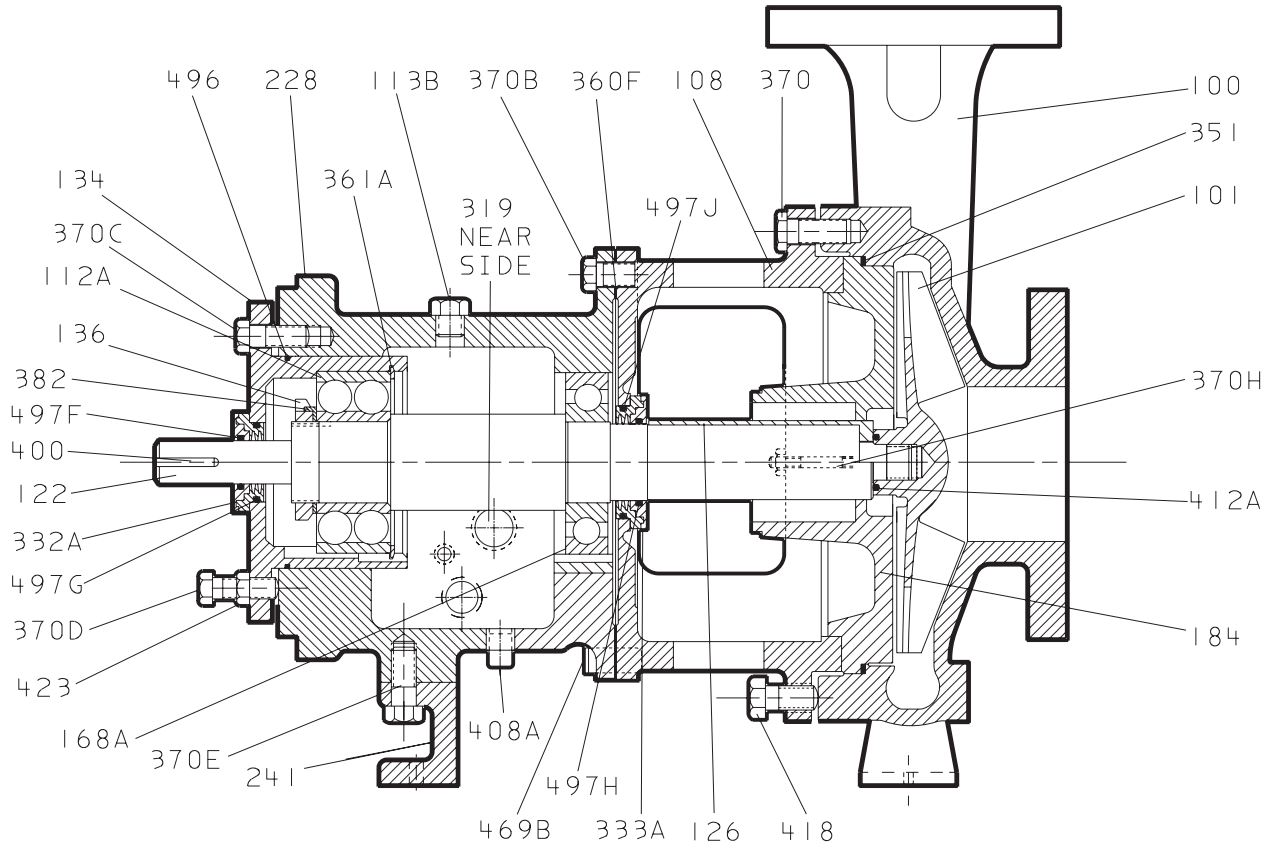

# Model CV 3196 Cross Sectional

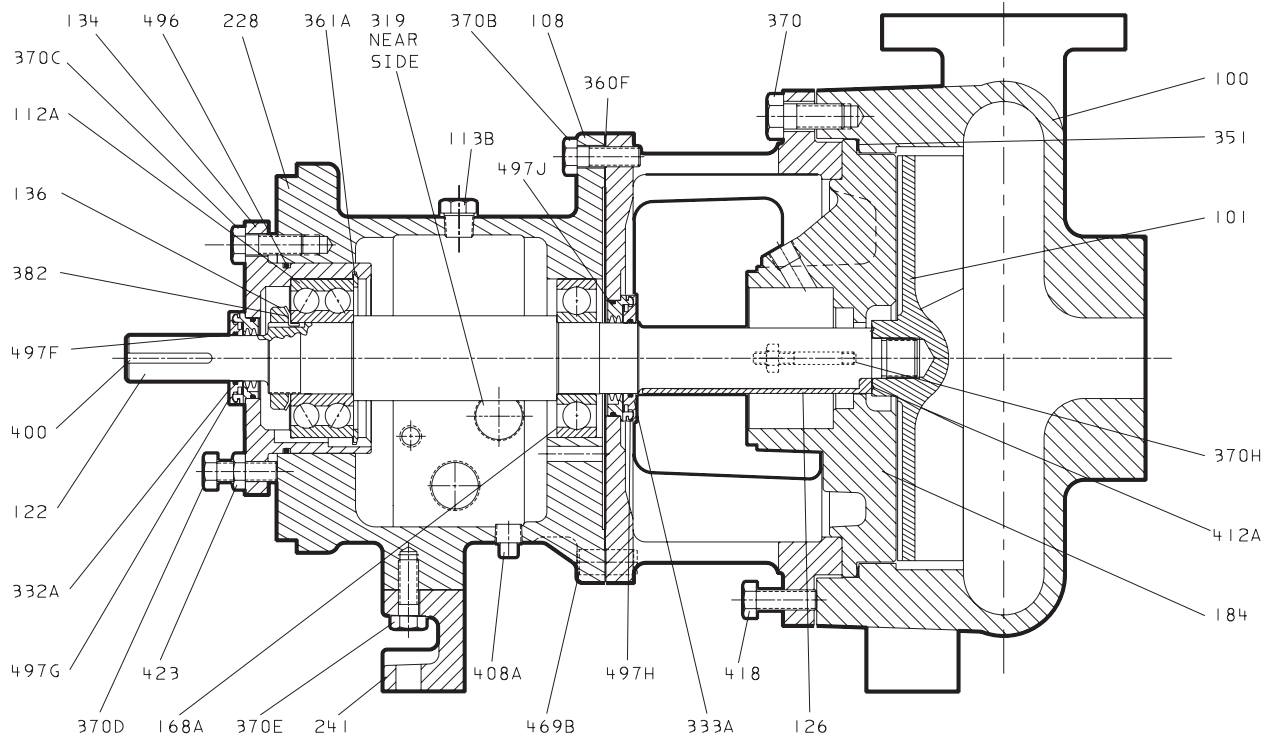

6





# Model LF 3196 Cross Sectional

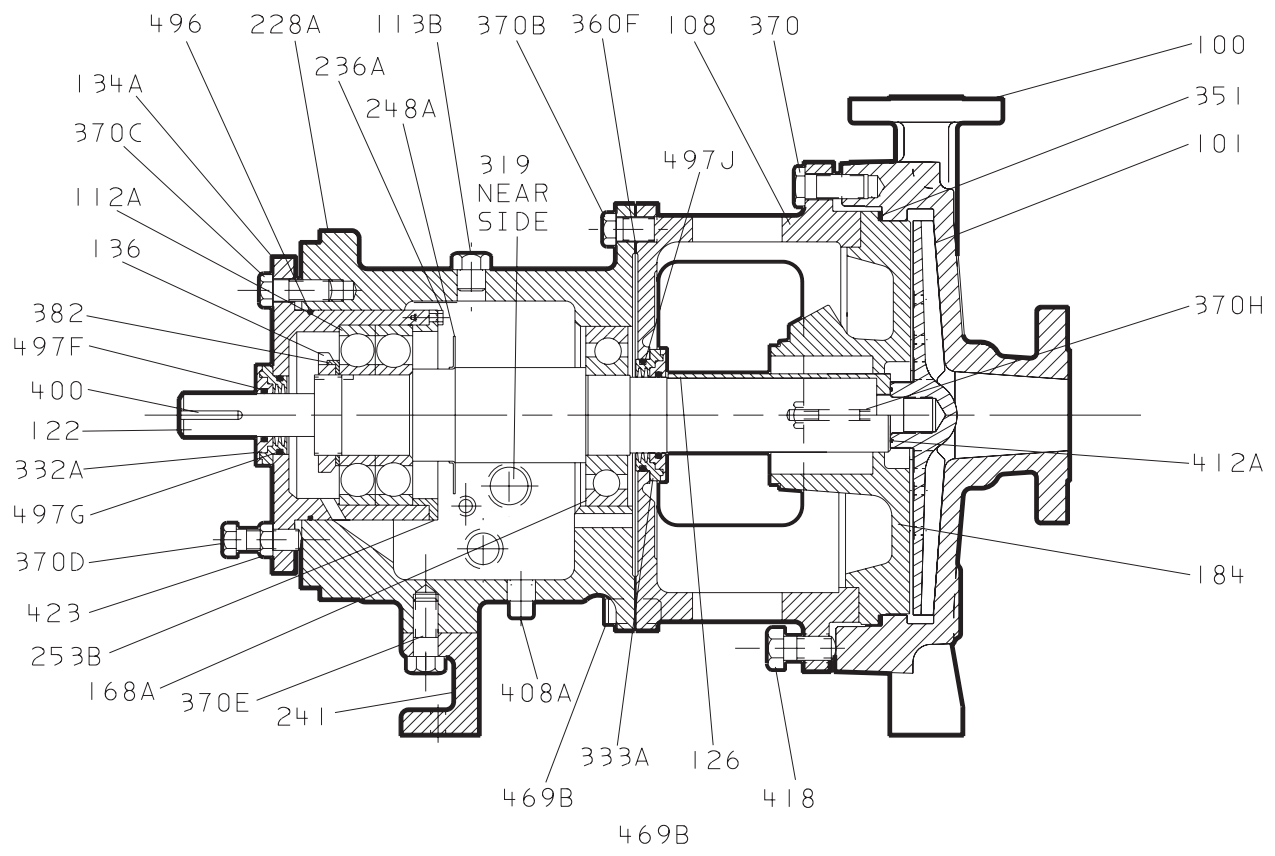

6

# Model NM 3196 Cross Sectional

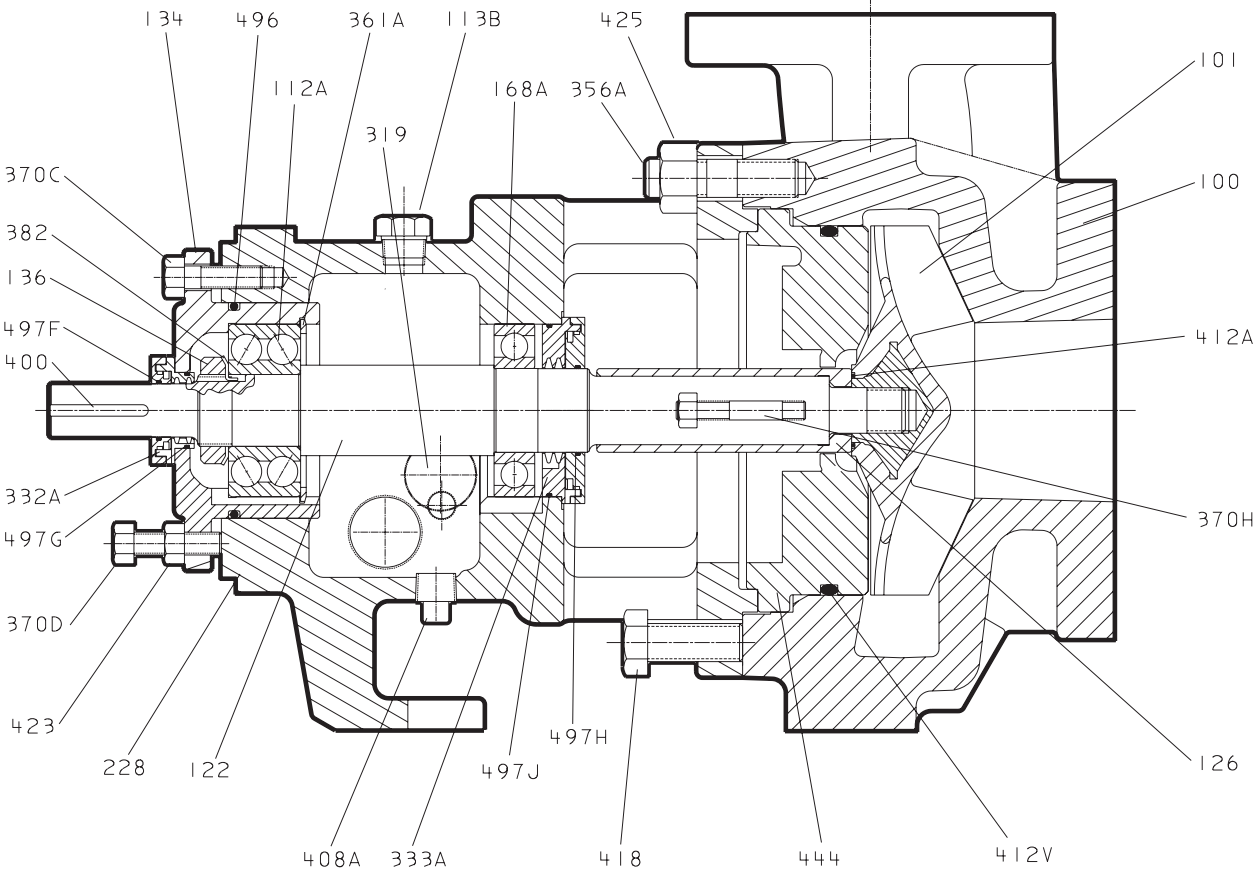

# Model 3198 Cross Sectional

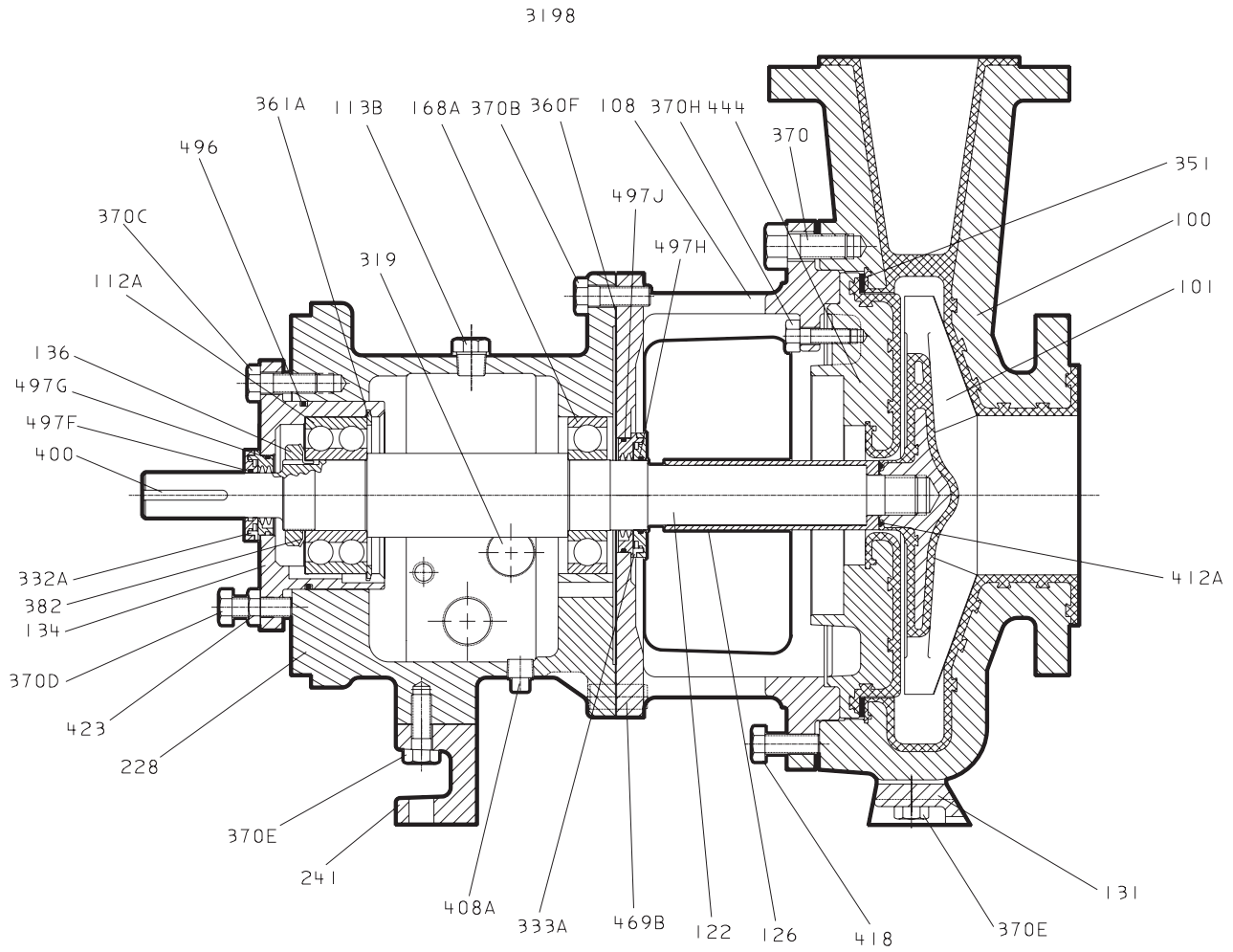

**6**

# Model 3796 Cross Sectional

3796 MTX

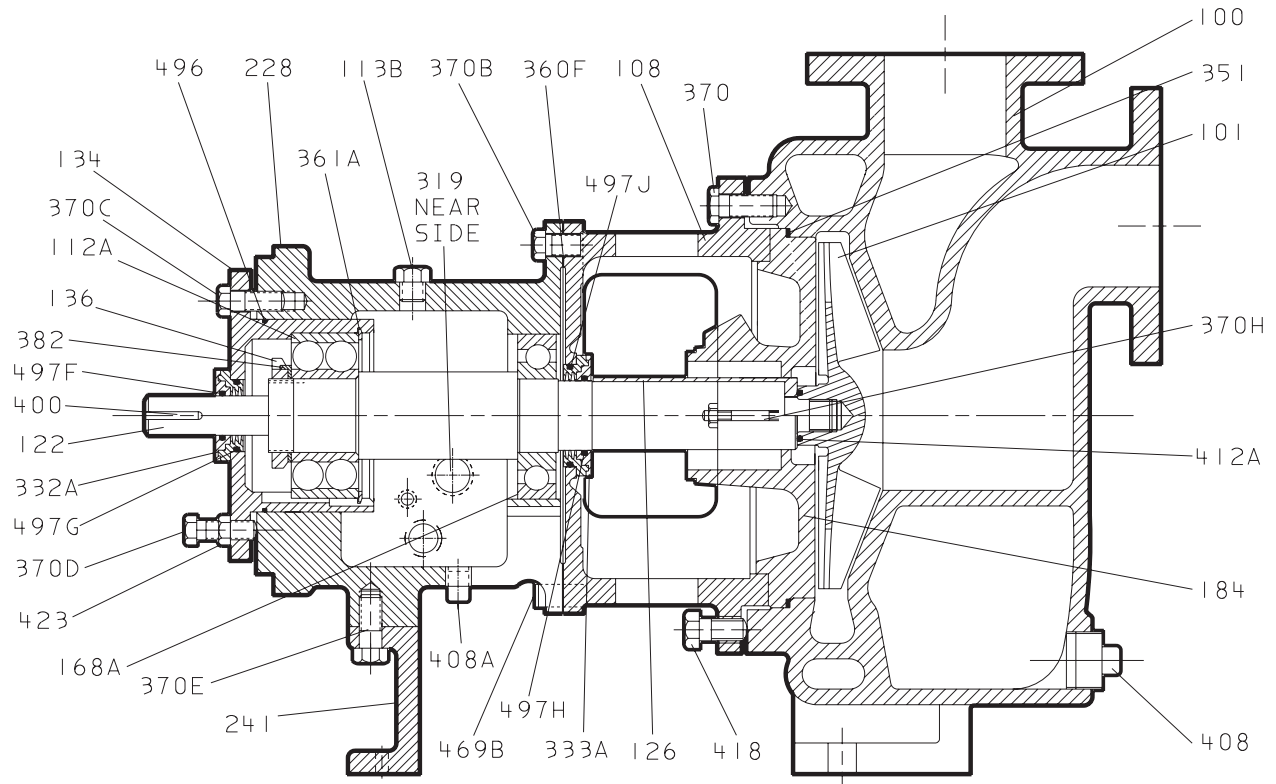

# STX Power End

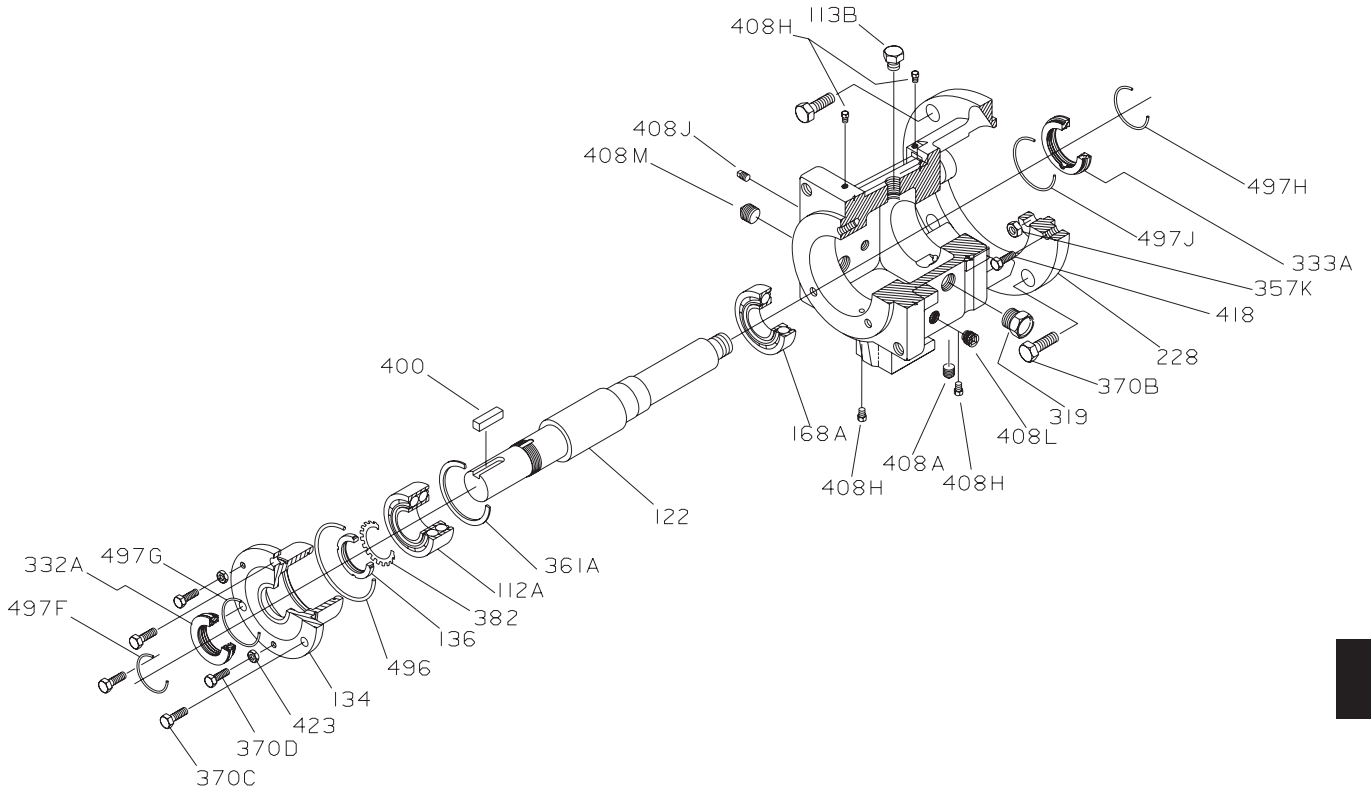

6

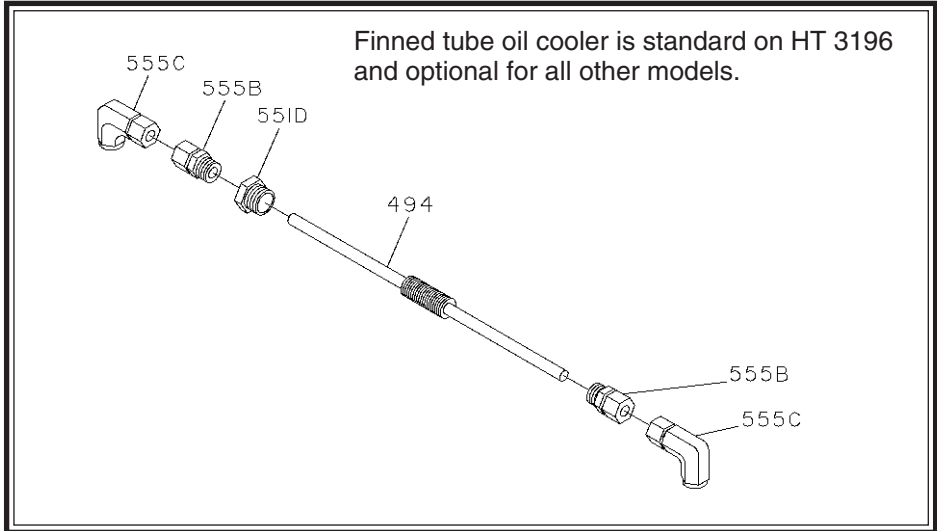

# MTX Power End

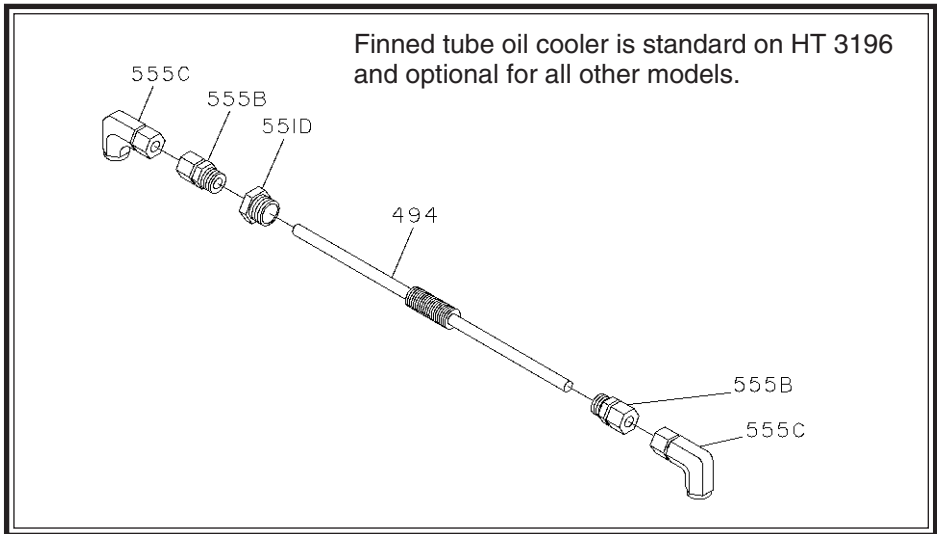
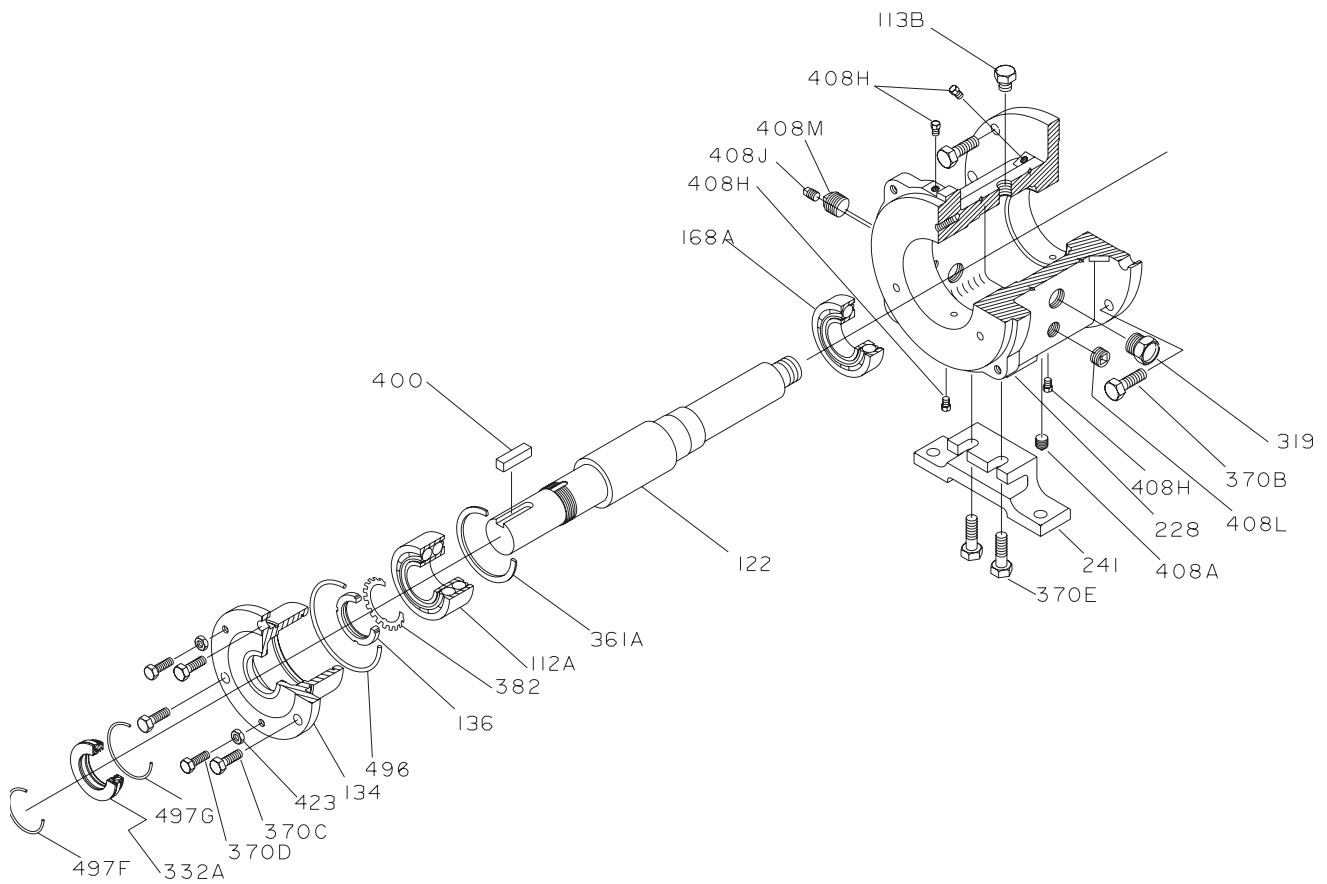

# LTX Power End

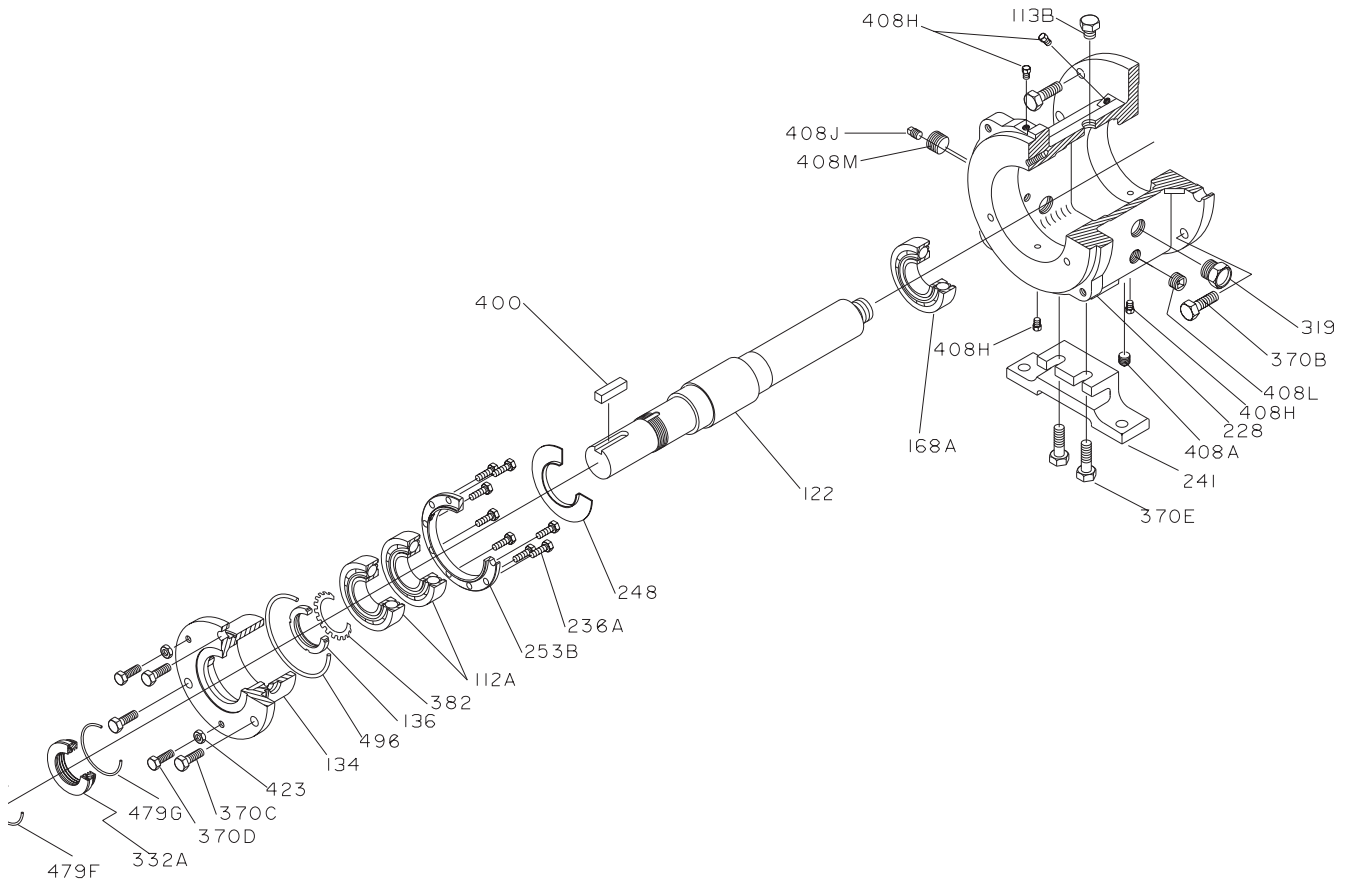

6

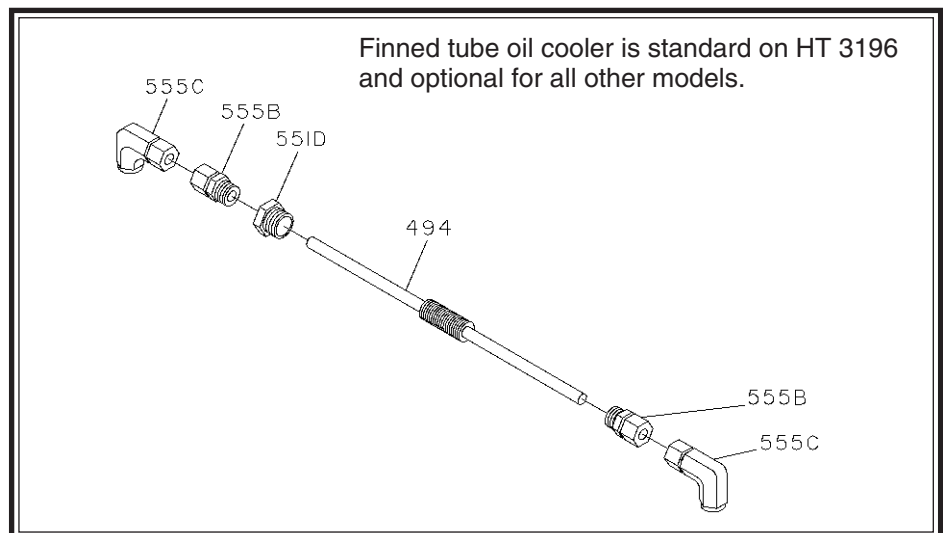

# XLT-X Power End

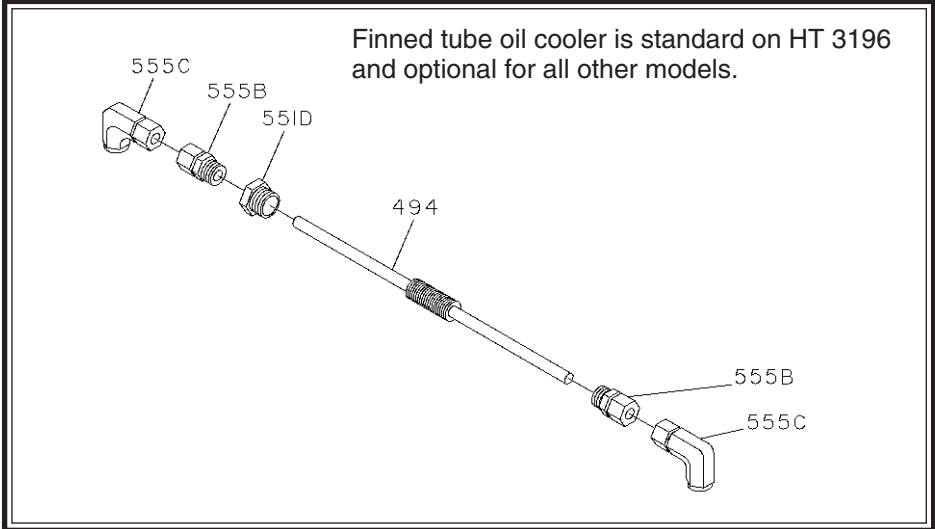
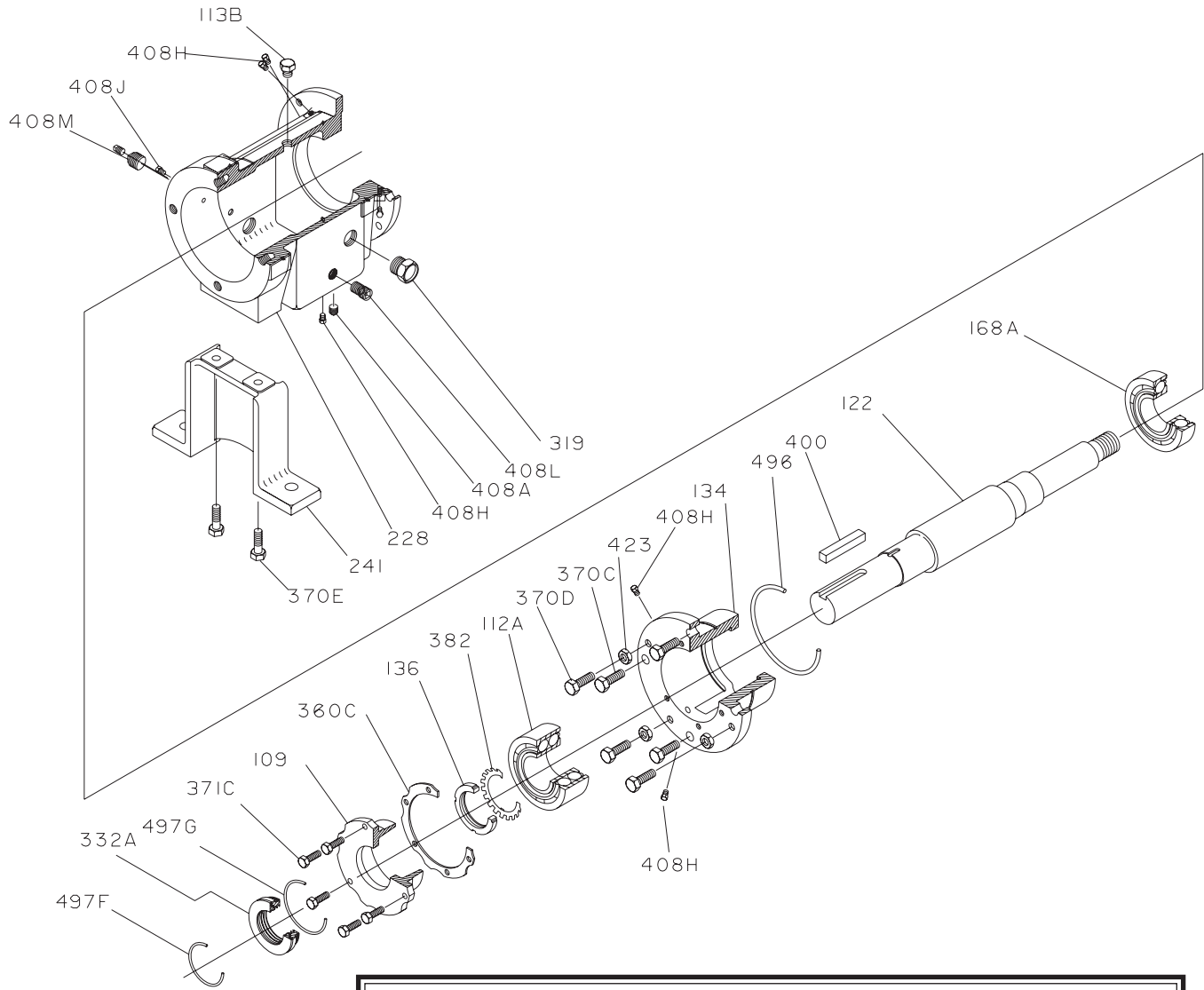



# SPARE PARTS

<b>RECOMMENDED SPARE PARTS</b> . . . . .	<b>111</b>
<b>INTERCHANGEABILITY</b> . . . . .	<b>112</b>
<b>APPENDIX I</b>	<b>Frame Lubrication Conversion . . . . . 119</b>
<b>APPENDIX II</b>	<b>Installation Instructions for . . . . . 123</b>
	<b>ITT Goulds ANSI B15.1 Coupling Guards</b>
<b>APPENDIX III</b>	<b>Alignment . . . . . 127</b>
<b>APPENDIX IV</b>	<b>Labyrinth Seal Installation Instructions . . . . 131</b>
<b>APPENDIX V</b>	<b>C-Face Adapter Installation Instructions. . . . 133</b>
<b>APPENDIX VI</b>	<b>3198 Teflon® Sleeve Field Replacement. . . . 135</b>
	<b>Procedure</b>
<b>APPENDIX VII-1</b>	<b>Double Row Angular Bearing . . . . . 137</b>
	<b>Installation Instructions</b>
<b>APPENDIX VII-2</b>	<b>Duplex Angular Contact Bearing . . . . . 139</b>
	<b>Installation Instructions</b>
<b>APPENDIX VIII</b>	<b>INPRO Labyrinth Oil Seal . . . . . 141</b>
	<b>Installation Instructions</b>

When ordering spare parts, always state ITT Goulds Serial No. and indicate part name and item number from relevant sectional drawing. It is imperative for service reliability to have a sufficient stock of readily available spares.

## RECOMMENDED SPARE PARTS

- Impeller (101)
- Shaft (122A)
- Shaft Sleeve (126)
- Outboard Bearing (112A)
- Inboard Bearing (168A)
- Casing Gasket (351)
- Frame-to-Adapter Gasket (360D)
- Bearing Housing Retaining Ring (361A)
- Bearing Lockwasher (382)
- Bearing Locknut (136)
- Impeller O-Ring (412A)
- Bearing Housing O-Ring (496)
- Outboard Labyrinth Seal Rotary O-Ring (497F)
- Outboard Labyrinth Seal Stationary O-Ring (497G)
- Inboard Labyrinth Seal Rotary O-Ring (497H)
- Inboard Labyrinth Seal Stationary O-Ring (497J)
- Lantern Ring Half (105) (Packed Stuffing Box)
- Stuffing Box Packing (106) (Packed Stuffing Box)
- Packing Gland (107) (Packed Stuffing Box)
- Impeller Gasket (428D) XLT-X & X17

# INTERCHANGEABILITY

## 3196 MODULAR/DIMENSIONAL INTERCHANGEABILITY

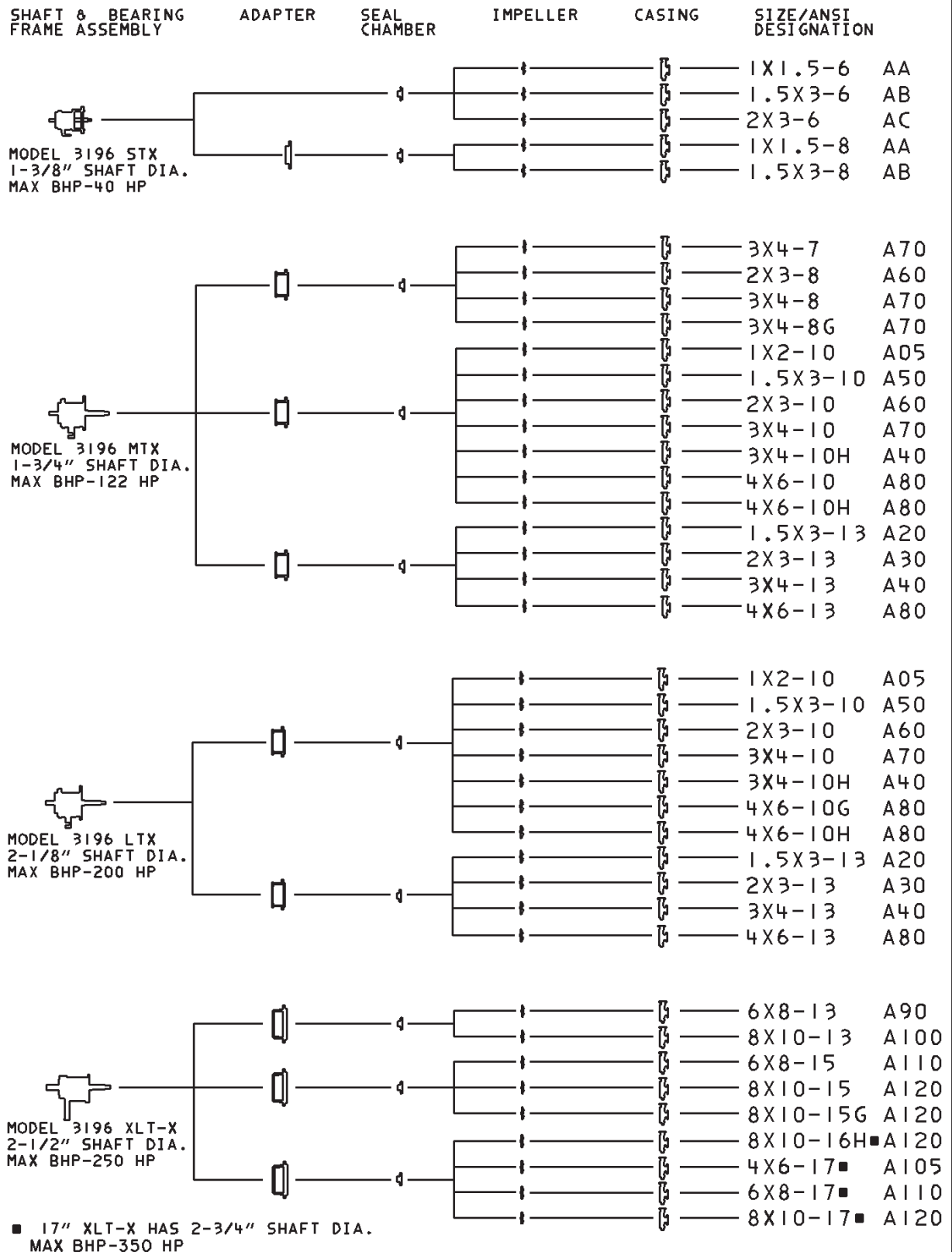

# INTERCHANGEABILITY

## CV 3196 MODULAR/DIMENSIONAL INTERCHANGEABILITY

SHAFT & BEARING  
FRAME ASSEMBLY

ADAPTER

SEAL  
CHAMBER

IMPELLER

CASING

SIZE

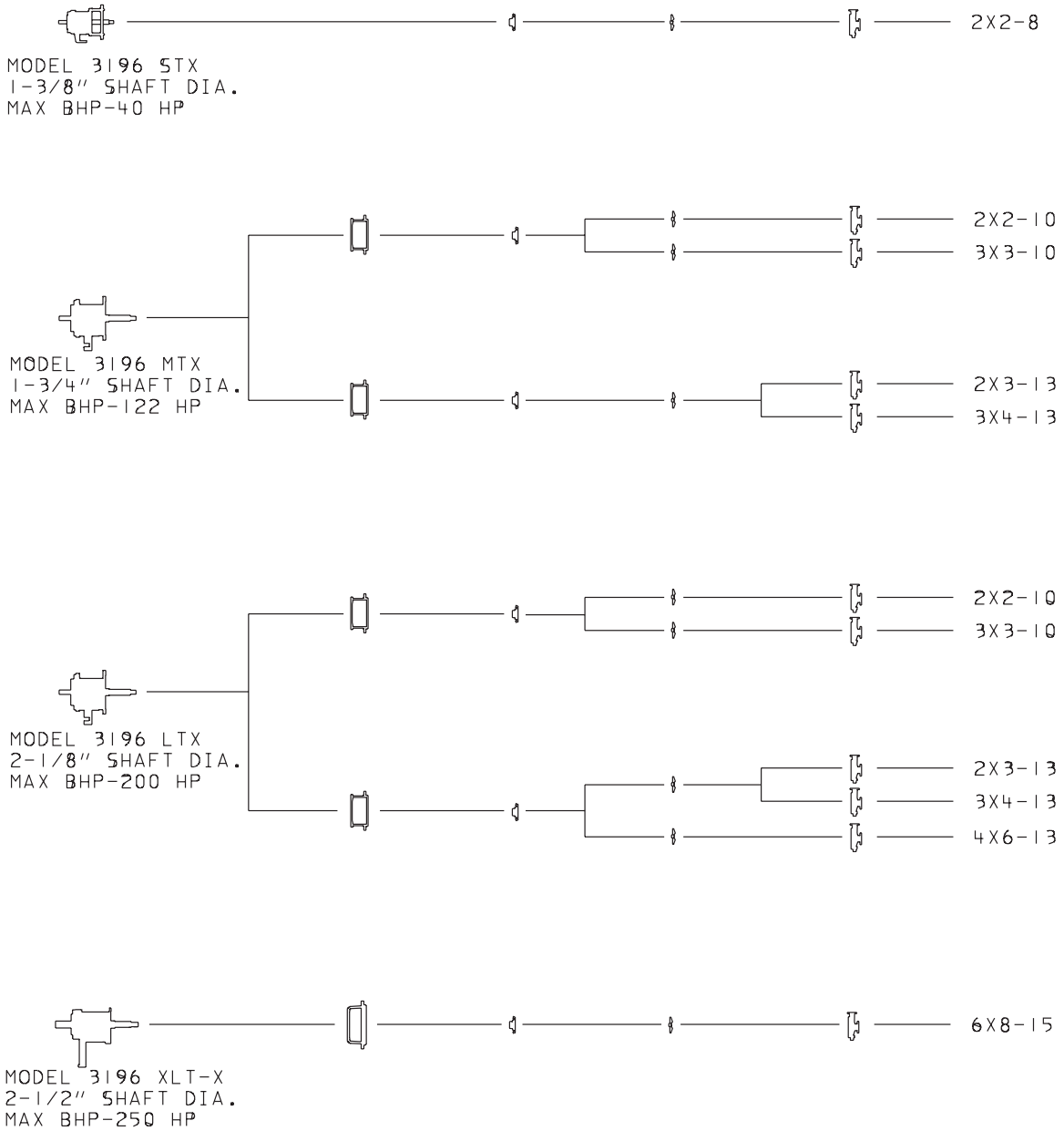

# INTERCHANGEABILITY

## HT3196 MODULAR/DIMENSIONAL INTERCHANGEABILITY

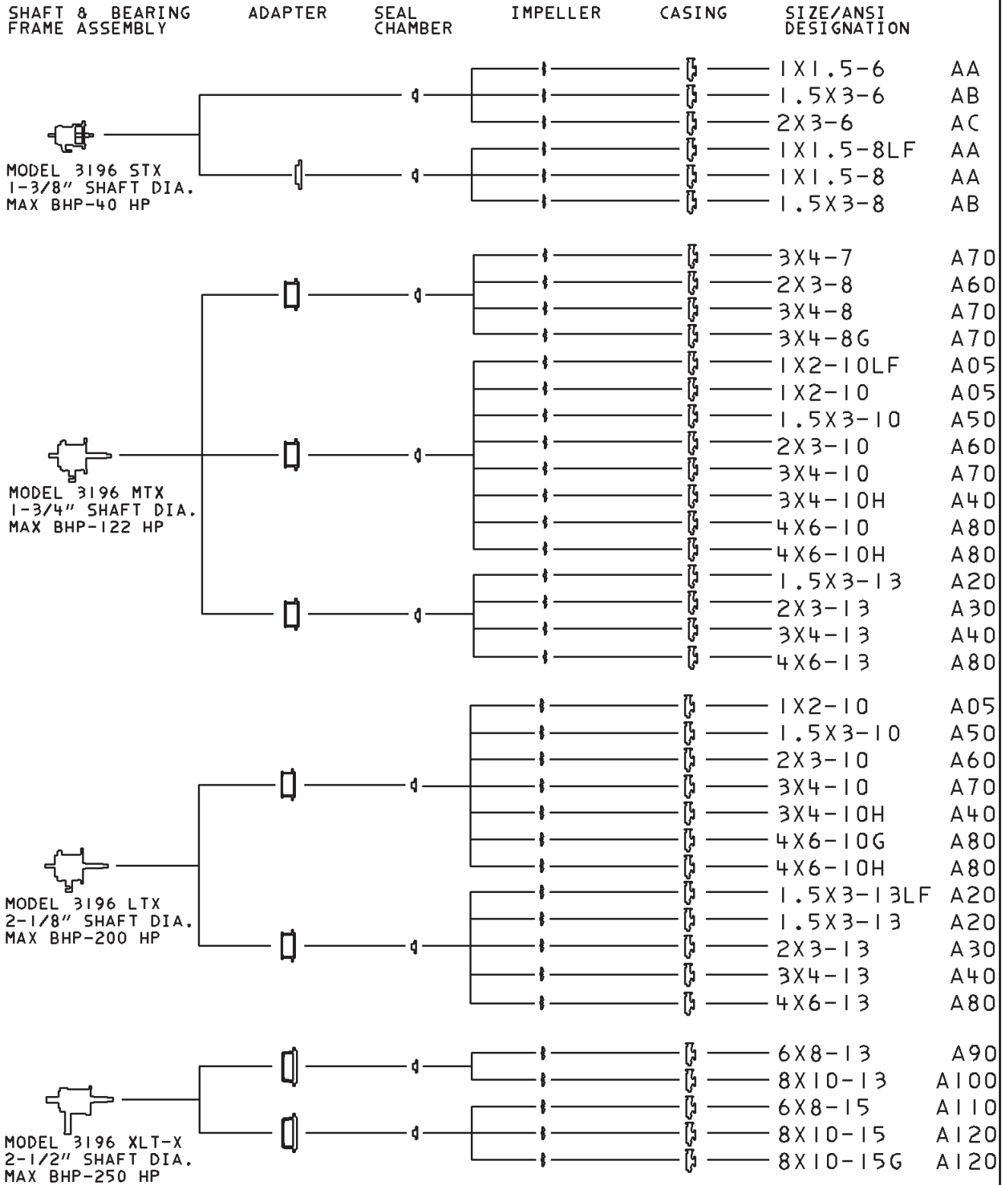

# INTERCHANGEABILITY

## LF 3196 MODULAR/DIMENSIONAL INTERCHANGEABILITY

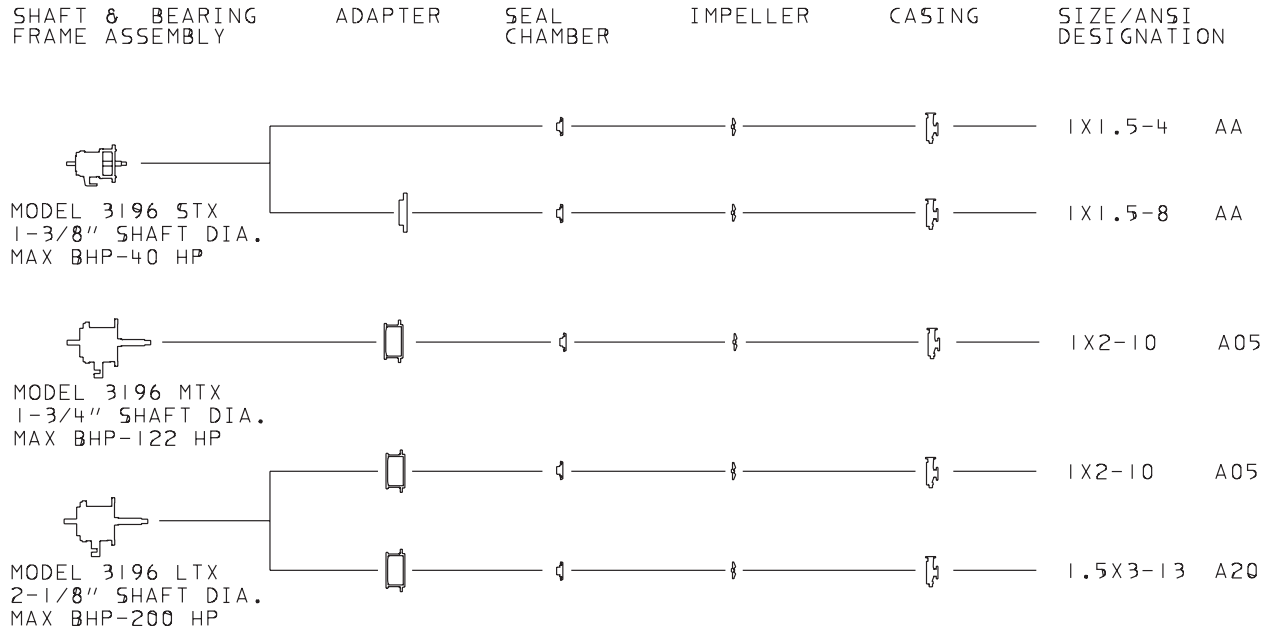

# INTERCHANGEABILITY

## NM 3196 MODULAR/DIMENSIONAL INTERCHANGEABILITY

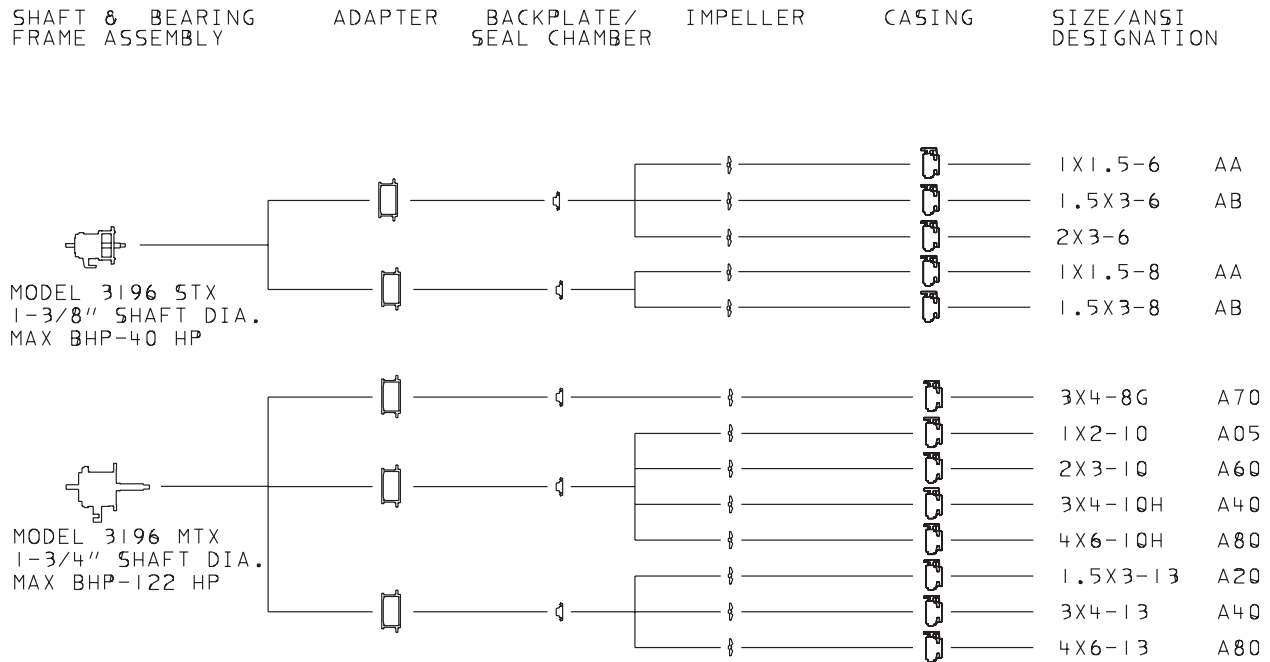

# INTERCHANGEABILITY

## 3198 MODULAR/DIMENSIONAL INTERCHANGEABILITY

SHAFT & BEARING  
FRAME ASSEMBLY

ADAPTER

BACKPLATE/  
SEAL CHAMBER

IMPELLER

CASING

SIZE/ANSI  
DESIGNATION

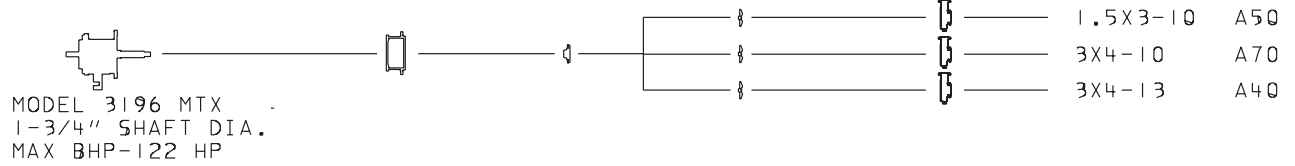

# INTERCHANGEABILITY

## 3796 MODULAR/DIMENSIONAL INTERCHANGEABILITY

SHAFT & BEARING  
FRAME ASSEMBLY

ADAPTER

SEAL  
CHAMBER

IMPELLER

CASING

SIZE

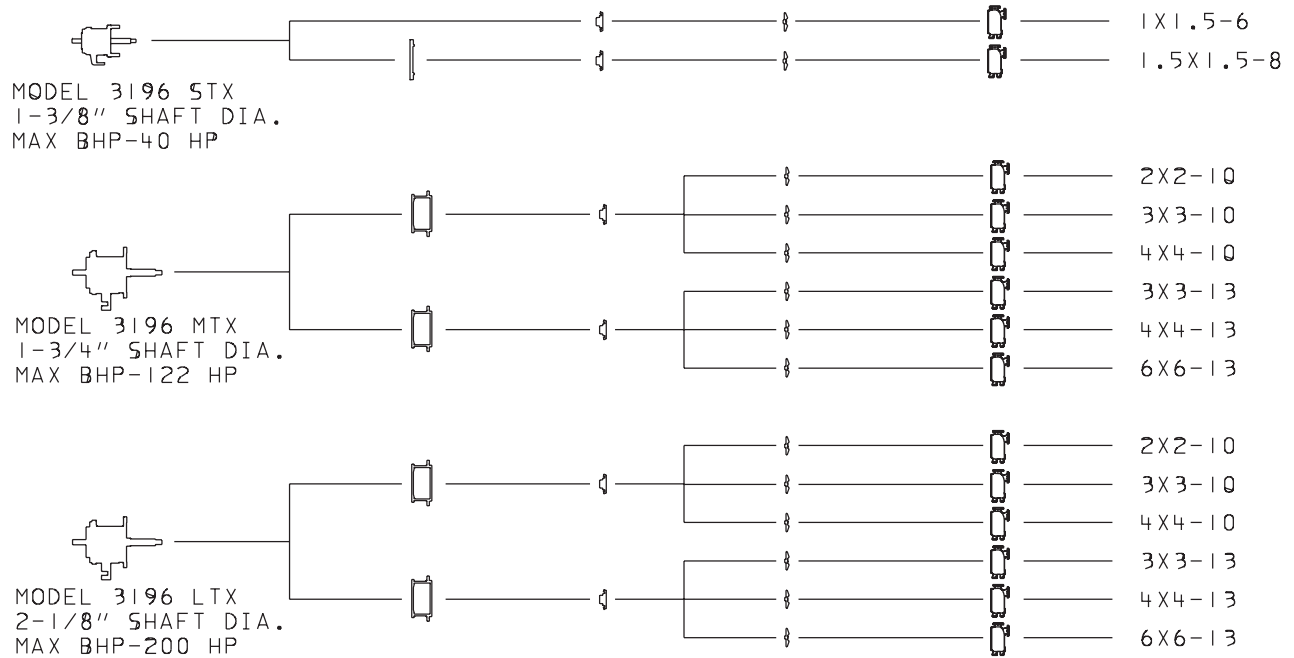



# APPENDIX I

## Frame Lubrication Conversion

Lubrication Conversion		
	Pumpage Temperature below 350°F (177°C)	Pumpage Temperature above 350°F (177°C)
NLGI Consistency	2	3
Mobil	Mobilux EP2	SCH32
Exxon	Unirex N2	Unirex N3
Sunoco	Multipurpose 2EP	
SKF	LGMT 2	LGMT 3

Pumpage temperatures above 350°F (177°C) should be lubricated by a high temperature grease. Mineral oil greases should have oxidation stabilizers and a consistency of NLGI 3.

**NOTE: If it is necessary to change grease type or consistency, the bearings must be removed and the old grease removed.**



### CAUTION

**Never mix greases of different consistency (NLGI 1 or 3 with NLGI 2) or different thickener soaps (sodium or calcium with lithium). The consistency usually becomes softer and will not provide adequate lubrication to the bearings.**

## FRAME LUBRICATION CONVERSION

### Conversion from Flood Oil to Pure Oil Mist

There are several ways to apply oil mist. ITT Goulds has designed X-Series Power Ends to accept a variety of oil mist configurations. The following instructions are written for two popular systems in use.

**NOTE: Make sure that pipe threads are clean and apply thread sealant to plugs & fittings.**

**NOTE: The LTX requires that the bearing housing be changed when making the conversion from flood oil to oil mist lubrication. After the proper bearing housing has been installed follow the instructions as they apply to STX, MTX, XLT-X, X17.**

#### A. Non-Vented Oil Mist System

1. Attach oil mist inlet to ¼" NPT connection at top, outboard end of frame (plugged with 408H allen head plug), and top, center of frame (plugged with 113A hex head plug).
2. Attach drain at bottom center of frame ⅜" NPT hole (plugged with 408A magnetic drain plug).
3. Follow oil mist generator manufacturer's instructions for oil mist volume adjustment, and

operation.

#### B. Vented Oil Mist System

1. Attach oil mist inlet connection to ¼" NPT connections at outboard and inboard ends of frame.
2. Attach vent connection at ½" NPT hole located in top center of frame.
3. Attach drain connection at ⅜" NPT hole located at bottom center of frame (plugged with 408A magnetic drain plug).
4. Follow oil mist generator manufacturer's instructions for oil mist volume adjustment and operation.

8



### CAUTION

**Oil mist falls under Title III of the Clean Air Act and must be controlled or the user will be subject to penalty.**

## Conversion from Flood Oil to Regreaseable

**NOTE:** Make sure that pipe threads are clean and apply thread sealant to plugs and fittings.

**NOTE:** LTX regreaseable power end requires a changeout of the bearing housing and bearing clamp ring. This housing provides a grease path to the bearings.

1. Plug inboard oil return in bearing frame.  
**STX:** Use epoxy, keep drilled hole clear.  
  
**MTX, LTX, XLT-X, X17:** Use set screw, install from adapter side, bottom in hole.
2. Plug outboard oil return slot in bearing housing, keep through holes clear. (does not apply to LTX)
3. Replace both bearings with single shield type. Refer to Assembly Section for installation guidelines. (Ref. Bearing Chart Table 11)
4. Install grease fittings at top, inboard and top, outboard ¼" NPT connections in bearing frame (plugged with 408H allen head plug).
5. Remove 2 (408H) Allen head plugs from bottom side of frame prior to greasing bearings. Reinstall hex head plugs (113) after bearings have been greased.

## X-Series Conversion from Greased for Life or Regreaseable to Oil Lubricated Bearings

**NOTE:** LTX bearing housing and clamp ring are not interchangeable between oil and grease lubrication.

1. Remove plug from oil return slot in the frame, under the radial bearing.  
  
**STX:** Remove epoxy from return slot.  
  
**MTX, LTX, XLT-X, X-17:** Remove set screw installed in the oil return hole.
2. Remove plug from oil return hole in the bearing housing (134). For LTX only, housing (134) and clamp ring (253B) require replacement. Contact ITT Goulds for price and availability.
3. Replace both bearings with unshielded, oil lube bearings. Refer to Assembly Section for installation guidelines. (Ref. Bearing Chart, Table 11).
4. Grease fittings should be removed to prevent accidental greasing. Quantity of two (2) plugs (408H) are required to replace the two (2) grease fittings (193).

Item No.	Size	Description	Qty.
113	1/4"-18 NPT	Ext. Hex/square Head Pipe Plug	2
113A	1/2"-14 NPT	Ext. Hex/square Head Pipe Plug	1
193	1/4"-18 NPT	Grease Fitting	2
228	----	Bearing Frame	1
241	----	Frame Foot	1
370F	1/2"	Hex Cap Screw	2
408A	3/8"-18 NPT	Ext. Square Head Pipe Plug (magnetic)	1
408J	1/4"-18 NPT	Ext. Hex/square Head Pipe Plug	1
408L	1/2"-14 NPT	Square Countersunk Headless Pipe Plug	1
408M	1" 11-1/2" NPT	Square Countersunk Headless Pipe Plug	1
319	1" 11-1/2" NPT	Sight Window	1
529	1/2"	Light Helical Spring Lock Washer	2

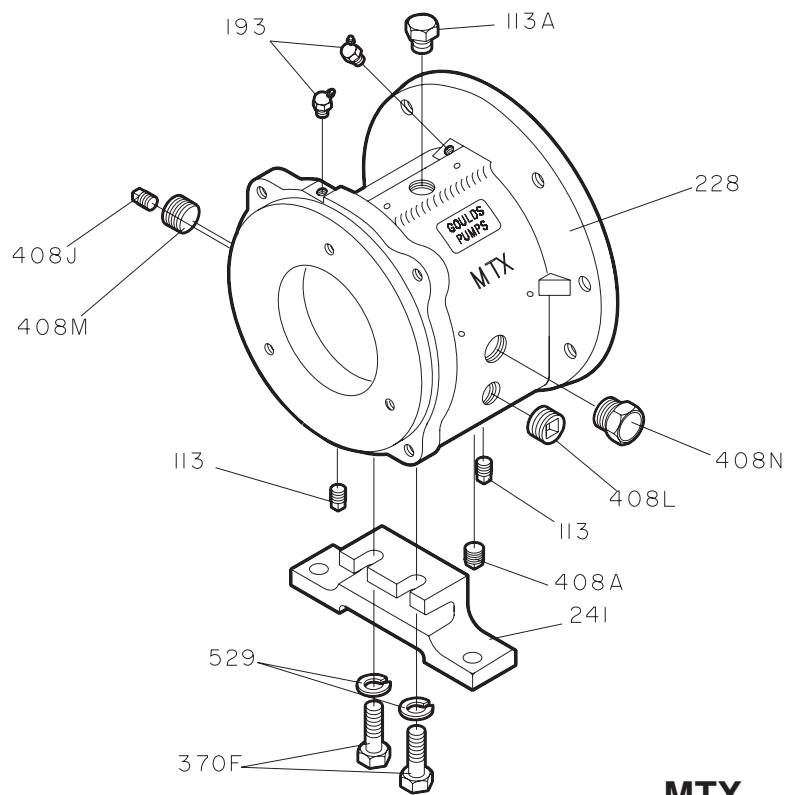

**MTX  
Grease Lube**



# APPENDIX II

## Installation Instructions for ITT Goulds ANSI B15.1 Coupling Guards



The coupling guard used in an Atex classified environment must be constructed from a non-sparking material.



### WARNING

Before assembly or disassembly of the coupling guard is performed the motor must be de-energized, the motor controller/starter put in a locked-out position and a caution tag placed at the starter indicating the disconnect. Replace coupling guard before resuming normal operation of the pump. ITT Goulds Pumps assumes no liability for avoiding this practice.

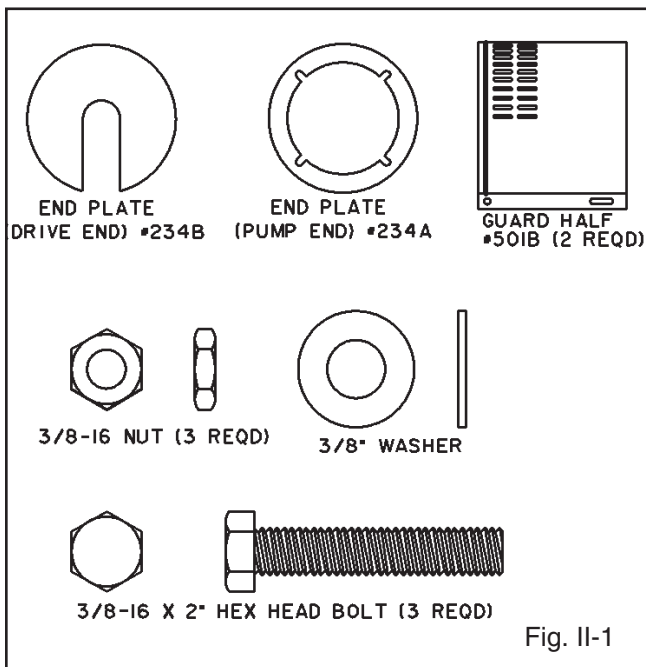

Fig. II-1

Simplicity of design allows complete assembly of the coupling guard, including the end plate (pump end), in about fifteen minutes. If the end plate is already in place, assembly can be accomplished in about five minutes.

### Assembly:

**NOTE:** If end plate (pump end) is already installed, make any necessary coupling adjustments and then proceed to Step 2.

1. **STX, MTX, LTX** - Align end plate (pump end) to the Bearing Frame. (No impeller adjustment required.)

**XLTX** Align the end plate (pump end) to the pump bearing housing so that the large slots on the end plate clear the bearing housing tap bolts and the small slots are aligned to the impeller adjusting bolts. Attach the end plate to the bearing housing using the jam nuts on the impeller adjusting bolts as shown in Fig. II-3.

After the end plate is attached to the bearing housing, the impeller clearance must be checked and reset as explained in Section V - Preventive Maintenance.

**NOTE:** Coupling adjustments should be completed before proceeding with coupling guard assembly.

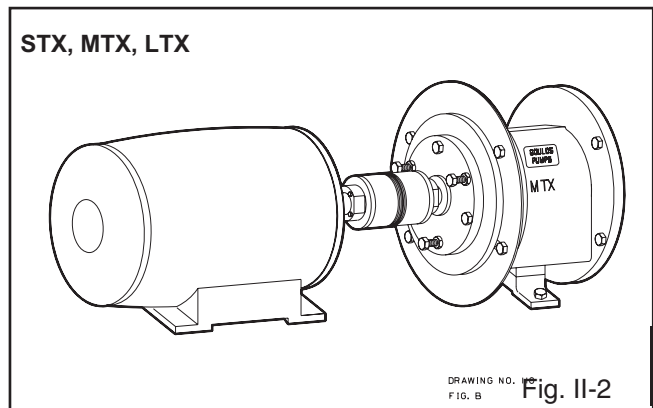

Fig. II-2

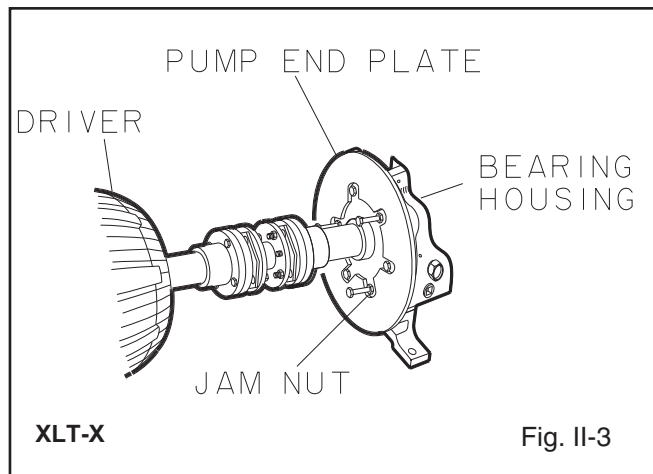
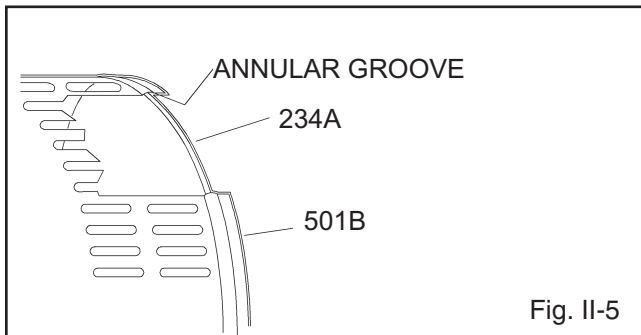
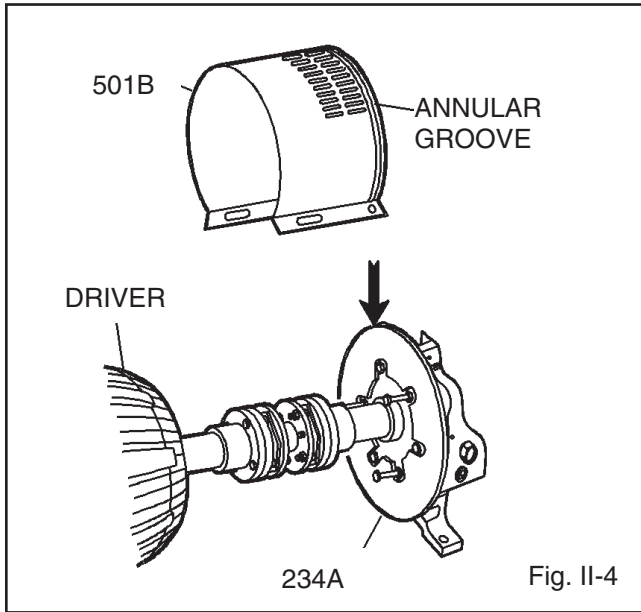
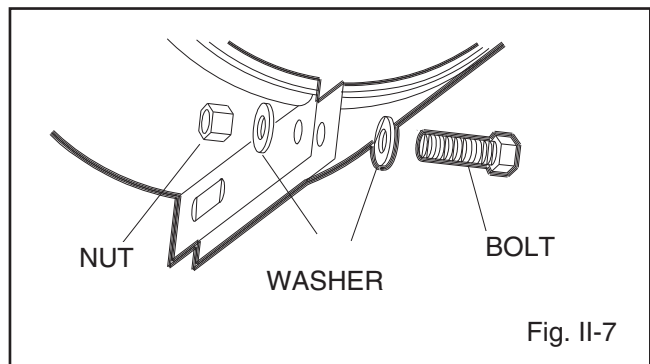
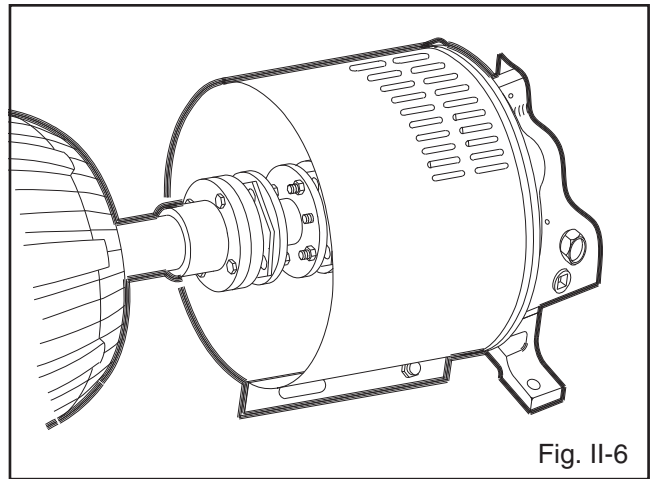

Fig. II-3

- Spread bottom of coupling guard half (pump end) slightly and place over pump end plate as shown in Fig. II-4. The annular groove in the guard half is located around the end plate (Fig. II-5).



- After the coupling guard half (pump end) is located around the end plate, secure it with a bolt, nut and two (2) washers through the round hole at the front end of the guard half as shown in Fig. II-6. Tighten securely (Fig. II-7).



- Spread bottom of coupling guard half (driver end) slightly and place over coupling guard half (pump end) so that annular groove in coupling guard half (driver end) faces the motor as shown in Fig. II-8.

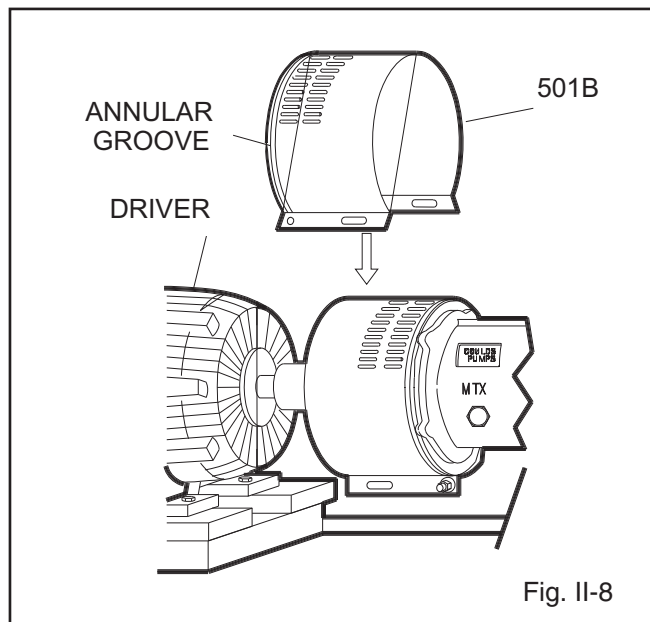

- Place end plate (driver end) over motor shaft as shown in Fig. II-9. Locate the end plate in the annular groove at the rear of the coupling guard half (driver end) and secure with a bolt, nut, and two (2) washers through the round hole at the rear of the guard half. Finger tighten only.

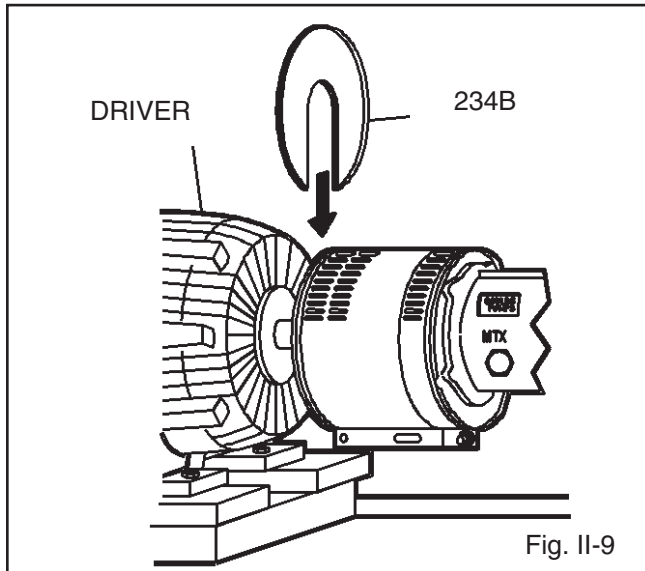

- Adjust length of coupling guard to completely cover shafts and coupling as shown in Fig. II-10 by sliding coupling guard half (driver end) towards motor. After adjusting guard length, secure with bolt, nut and two (2) washers through the slotted holes at the center of the guard and tighten. Check all nuts on the guard assembly for tightness.



### WARNING

*Before assembly or disassembly of the coupling guard is performed, the motor must be de-energized, the motor controller/starter put in a locked-out position and a caution tag placed at the starter indicating the disconnect. Replace coupling guard before resuming normal operation if the pump. ITT Goulds Pumps assumes no liability for avoiding this practice.*

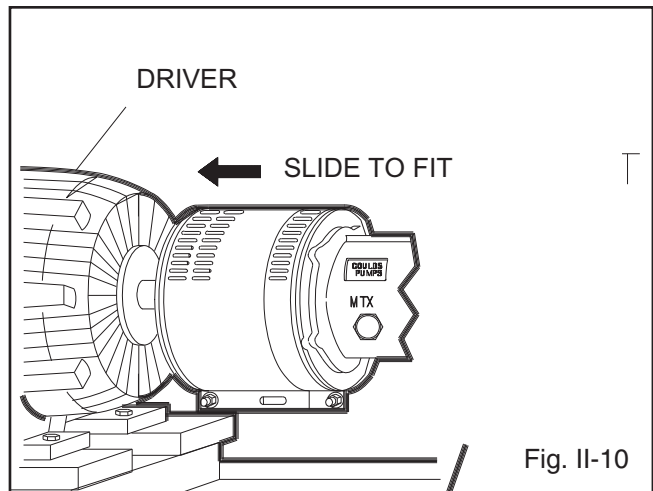

### Disassembly

The coupling guard must be removed for certain maintenance and adjustments to the pump, such as adjustment of the coupling, impeller clearance adjustment, etc. The coupling guard should be replaced after maintenance is completed.

**DO NOT resume normal pump operation with the coupling guard removed.**

**NOTE: Refer to illustrations for assembly in reverse order.**

- Remove nut, bolt, and washers from center slotted hole in the coupling guard. Slide motor end coupling guard half towards pump. Fig. II-10.
- Remove nut, bolt, and washers from coupling guard half (driver end), and remove end plate. Fig. II-9.
- Spread bottom of coupling guard half slightly and lift off. Fig. II-8.
- Remove remaining nut, bolt, and washers from coupling guard half (pump end). Spread bottom of coupling guard half slightly and lift off. Fig. II-4.

This completes disassembly of the coupling guard.

**NOTE: It is not necessary to remove the end plate (pump end) from the pump bearing housing. The bearing housing tap bolts are accessible without removing the end plate in case maintenance of internal pump parts is necessary. Before removing the pump bearing housing, refer to Section 6 - Disassembly & Reassembly.**





# APPENDIX III

## Alignment



**Alignment procedures must be followed to prevent unintended contact of rotating parts. Follow coupling manufacturer's coupling installation and operation procedures.**

### SET UP

1. Mount two dial indicators on one of the coupling halves (X) so they contact the other coupling half (Y) (Fig. III-1).
2. Check setting of indicators by rotating coupling half X to ensure indicators stay in contact with coupling half Y but do not bottom out. Adjust indicators accordingly.

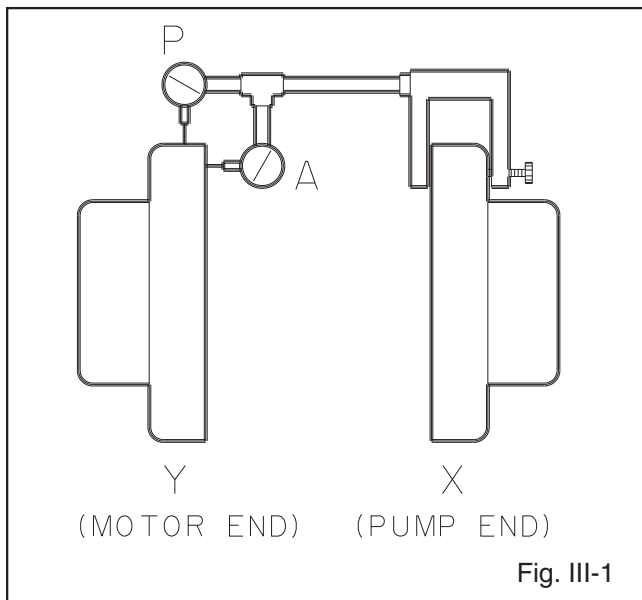

Fig. III-1

### MEASUREMENT

1. To ensure accuracy of indicator readings, always rotate both coupling halves together so indicators contact the same point on coupling half Y. This will eliminate any measurement problems due to runout on coupling half Y.
2. Take indicator measurements with driver feet hold-down bolts tightened. Loosen hold down bolts prior to making alignment corrections.
3. Take care not to damage indicators when moving driver during alignment corrections.

### ANGULAR ALIGNMENT

A unit is in angular alignment when indicator A (Angular indicator) does not vary by more than .002 in. (.05 mm) as measured at four points 90° apart.

#### Vertical Correction (Top-to-Bottom)

1. Zero indicator A at top dead center (12 o'clock) of coupling half Y.
2. Rotate indicators to bottom dead center (6 o'clock). Observe needle and record reading.
3. **Negative Reading** - The coupling halves are further apart at the bottom than at the top. Correct by either raising the driver feet at the shaft end (add shims) or lowering the driver feet at the other end (remove shims), (Fig. III-2).

**Positive Reading** - The coupling halves are closer at the bottom than at the top. Correct by either lowering the driver feet at the shaft end (remove shims) or raising the driver feet at the other end (add shims).

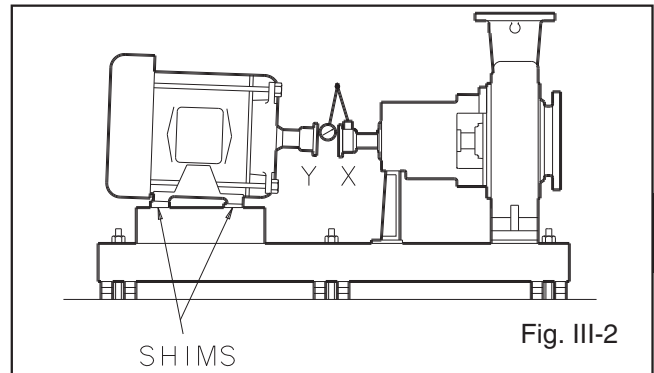

Fig. III-2

4. Repeat steps 1-3 until indicator A reads .002 in (.05 mm) or less.

#### Horizontal Correction (Side-to-Side)

1. Zero indicator A on left side of coupling half Y, 90° from top dead center (9 o'clock).
2. Rotate indicators through top dead center to the right side, 180° from the start (3 o'clock). Observe needle and record reading.
3. **Negative Reading** - The coupling halves are further apart on the right side than the left. Correct by either sliding the shaft end of the driver to the left or the other end to the right.

3. **Positive Reading** - The coupling halves are closer together on the right side than the left. Correct by either sliding the shaft end of the driver to the right or the other end to the left (Fig. III-3).

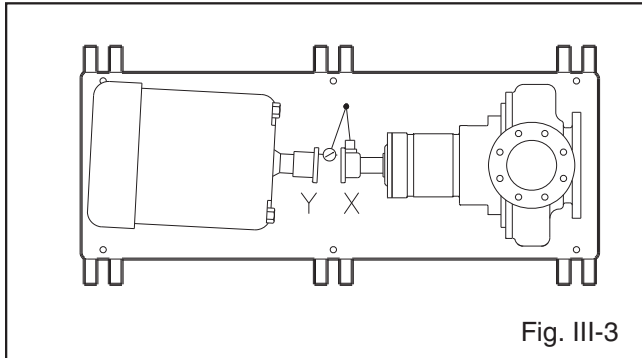

4. Repeat steps 1 through 3 until indicator A reads .002 in. (.05 mm) or less.
5. Re-check both horizontal and vertical readings to ensure adjustment of one did not disturb the other. Correct as necessary.

## PARALLEL ALIGNMENT

A unit is in parallel alignment when indicator P (parallel indicator) does not vary by more than .002 in. (.05 mm) as measured at four points 90° apart at operating temperature. Note the preliminary vertical cold setting criteria, Table 1.

### Vertical Correction (Top-to-Bottom)

1. Zero indicator P at top dead center of coupling (12 o'clock) half Y (Fig. III-1).
2. Rotate indicator to bottom dead center (6 o'clock). Observe needle and record reading.
3. **Negative Reading** - Coupling half X is lower than coupling half Y. Correct by removing shims of thickness equal to half of the indicator reading under each driver foot.

**Positive Reading** - Coupling half X is higher than coupling half Y. Correct by adding shims of thickness equal to half of the indicator reading from each driver foot (Fig. III-4).

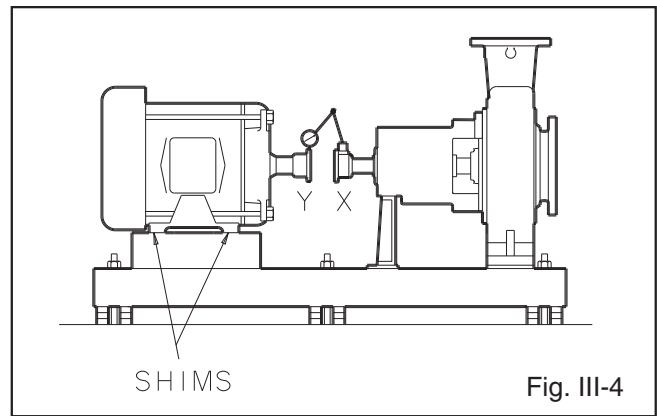

**NOTE:** Equal amounts of shims must be added to or removed from each driver foot. Otherwise the vertical angular alignment will be affected.

4. Repeat steps 1 through 3 until indicator P reads within .002 in. (.05 mm) or less when hot, or per Table 1 when cold.

### Horizontal Correction (Side-to-Side)

1. Zero indicator P on the left side of coupling half Y, 90° from top dead center (9 o'clock).
2. Rotate indicators through top dead center to the right side, 180° from the start (3 o'clock). Observe needle and record reading.
3. **Negative Reading** - Coupling half Y is to the left of coupling half X. Correct by sliding driver evenly in the appropriate direction (Fig. III-5).

**Positive Reading** - Coupling half Y is to the right of coupling half X. Correct by sliding driver evenly in the appropriate direction.

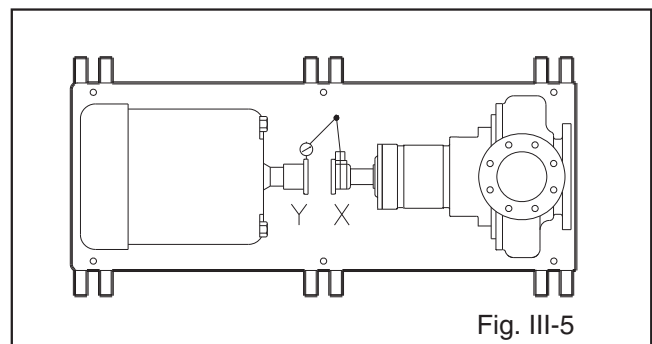

**NOTE:** Failure to slide motor evenly will affect horizontal angular correction.

4. Repeat steps 1 through 3 until indicator P reads .002 in. (.05 mm) or less.
5. Re-check both horizontal and vertical readings to ensure adjustment of one did not disturb the other. Correct as necessary.

## COMPLETE ALIGNMENT

A unit is in complete alignment when both indicators A (angular) and P (parallel) do not vary by more than .002 in. (.05 mm) as measured at four points 90° apart.

### Vertical Correction (Top-to-Bottom)

1. Zero indicators A and P at top dead center (12 o'clock) of coupling half Y.
2. Rotate indicator to bottom dead center (6 o'clock). Observe the needles and record the readings.
3. Make corrections as outlined previously.

### Horizontal Correction (Side-to-Side)

1. Zero indicators A and P on the left side of coupling half Y, 90° from top dead center (9 o'clock).
2. Rotate indicators through top dead center to the right side, 180° from the start (3 o'clock). Observe the needle, measure and record the reading.
3. Make corrections as outlined previously.
4. Recheck both vertical and horizontal readings to ensure adjustment of one did not disturb the other. Correct as necessary.

**NOTE: With experience, the installer will understand the interaction between angular and parallel and will make corrections appropriately.**



# APPENDIX IV

## Old JM Clipper CFT Design Labyrinth Seal Installation Instructions

### Description of Operation

The labyrinth oil seal serves two functions. The first being to exclude environmental contamination from the power-end. This is accomplished with a series of tight clearance fits between the stationary and rotor. Any water that manages to enter the seal is eliminated from the seal through a drain slot located at the six o'clock position when installed.

On the oil side, a series of oil grooves are present to direct any oil between the shaft and stationary back into the oil sump through a drain slot at the six o'clock position.

Viton® O-rings are supplied as standard due to their chemical resistance. The stationary uses an O-ring to fit the labyrinth seal to the housing. The stator uses an O-ring to fit the labyrinth to the housing. The rotor uses an O-ring to seal along the shaft and to serve as the drive.

### Installation Procedures



#### CAUTION

*The ITT Goulds labyrinth oil seal is a one piece assembly. Do not attempt to separate the rotor and stator. Damage to the seal may result.*

1. Assemble the power end per the instructions in Section 6 - Disassembly & Reassembly.



#### CAUTION

*The edges of the keyway can be sharp. Failure to cover the keyway may result in a cut O-ring and a damaged seal.*

2. Wrap tape around the coupling end of the shaft to cover the keyway.

**NOTE:** *The smooth surface of electrical tape provides an excellent surface to slide the rotor O-ring over.*

3. Press the seal over the shaft into the thrust bearing housing or thrust bearing end cover by hand until the shoulder of the seal is seated against the housing/cover.

**NOTE:** *An O-ring lubricant is not required, but can be used if desired. If used, be sure the lubricant is compatible with the O-ring material and plant standards.*

4. **For STX units:** Press the seal over the shaft into the bearing frame by hand until the shoulder of the seal is seated against the frame.

**For all other units:** Once the frame adapter is installed on the bearing frame, press the seal over the shaft into the frame adapter by hand until the shoulder of the seal is seated against the adapter.

**NOTE:** *An O-ring lubricant is not required, but can be used if desired. If used, be sure the lubricant is compatible with the O-ring material and plant standards.*

**NOTE:** *During start-up when the parts of the labyrinth oil seal establish a voluntary running clearance, a small amount of wear is experienced as the parts are in contact. This wear produces a carbon filled Teflon® residue, visible at the outside diameter of the seal and at the drain slot. This is the result of the two surfaces being smoothed, similar to burnishing. A lubricant should not be applied between the faces at installation. Once the running clearance has been established, no further wear is experienced and no decrease in seal performance occurs as a result of the carbon/Teflon® residue.*

## Labyrinth Oil Seal Conversion (After Oct. '03)

As of October 2003 ITT Goulds has standardized on INPRO VBXX-D Brass Labyrinth Oil Seals over the old JM Clipper CFT design. As a result of this change, new part numbers have been assigned to the old JM Clipper CFT design as follows:

<b>Table IV-1 Labyrinth Oil Seal Conversion Part Numbers</b>		
	Old Part #	New Part #
STX Frame (Outboard)	D08717A01	D08717A44
STX Frame (Inboard)	D08717A02	D08717A45
MTX (Outboard)	D08717A03	D08717A46
MTX (Inboard)	D08717A04	D08717A47
LTX (Outboard)	D08717A05	D08717A48
LTX (Inboard)	D08717A06	D08717A49
XLTX (Outboard)	D08717A07	D08717A50
XLTX (Inboard)	D08717A08	D08717A51
* 3198 MTX (Inboard)	D08717A31	D08717A52

# APPENDIX V

## C-Face Adapter Installation Instructions

### Disassembly

1. Remove the motor by loosening the motor mounting bolts (371). Refer to *Table V-1* for the number of bolts.

**Table V-1  
Number of Motor Bolts**

Pump Frame	Motor frame	No. of Bolts
STX	All	4
MTX	143-286	4
	324-365	8



### CAUTION

*The motor may be heavy and should be properly supported with a clean, uncorroded eye bolt or a strap under both end bells.*

**NOTE:** Use of a C-Face adapter will result in one of the following configurations — a foot mounted adapter with an overhung motor or an unsupported adapter and a foot mounted motor.

2. Remove the C-Face adapter (340) from the pump bearing frame (228A) by loosening the four bolts (371N) attached to the bearing frame flange.

**NOTE:** Both coupling hubs do not need to be removed.

### Inspections

1. Visually inspect the C-face adapter (340) for cracks. Check surfaces for rust, scale, or debris. Remove all loose or foreign material (Fig. V-1).
2. Check for corrosion or pitting.

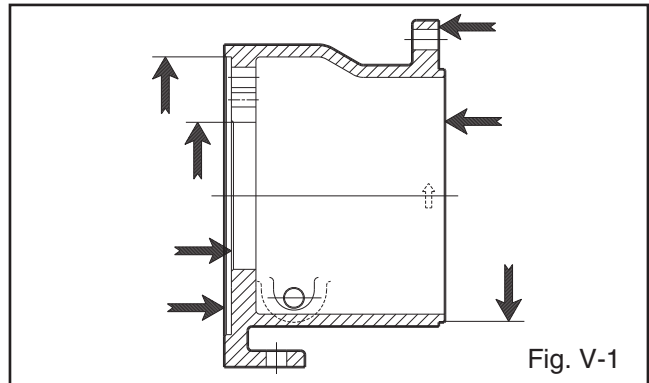

Fig. V-1

### Reassembly

1. Mount both the pump and motor coupling hubs if not already mounted.
2. Slide the C-Face adapter (340) over the pump shaft (122) and mount against the pump bearing frame (228A) flange using four bolts (371N). Torque bolts to the values shown in *Table V-2*.
3. Mount the motor to the C-Face adapter (340) using the four or eight motor bolts (371). Torque bolts to the values shown in *Table V-2*.

**Table V-2  
Bolt Torque**

Location	Frame	Lubricated Threads	Dry Threads
C-face adapter-to-frame	STX	20 ft-lbs (27 N-m)	30 ft-lbs (40 Nm)
	MTX	20 ft-lbs (27 N-m)	30 ft-lbs (40 Nm)
	LTX	20 ft-lbs (27 N-m)	30 ft-lbs (40 Nm)
C-face adapter-to-motor	143TC-145TC	8 ft-lbs (11 N-m)	12 ft-lbs (16 Nm)
	182TC-286TC	20 ft-lbs (27 N-m)	30 ft-lbs (40 Nm)
	324TC-365TC	39 ft-lbs (53 N-m)	59 ft-lbs (80 Nm)

## Alignment

A shaft alignment is not required when using the C-Face adapter. The rabbetted fits of the motor to the adapter and the adapter to the bearing frame automatically aligns the shaft to within the specified limits below.

The C-face motor adapter is intended for end users who need fast pump installation. A C-face adapter can attain a nominal alignment of 0.007 inches TIR. However, due to the stack up of machining tolerances of the various parts, the alignment can be as high as 0.015 inches TIR. Using a flexible, elastomer coupling like a Rexnord ES or Wood's Sureflex will provide acceptable pump and motor life under these alignment conditions.

To achieve the best Mean Time Between Pump Maintenance (MTBPM) requires shaft alignments of less than 0.002 inches (0.05mm). End users who require high pump and motor reliability are better served by using a foot mounted motor on a precision machined baseplate and performing a conventional alignment.



# APPENDIX VI

## 3198 Teflon® Sleeve Field Replacement Procedure

The Model 3198 Teflon® sleeve is field replaceable, provided a controlled oven capable of heating the sleeve to 550° F (228° C) and a method of machining the sleeve after installation on the shaft are available.



### CAUTION

**Do not heat the sleeve with an open flame. Irreparable damage will occur to the sleeve.**

For those users who do not have the above facilities, shaft/sleeve sub-assemblies are available from ITT Goulds.

1. Remove the old or damaged sleeve (126) from the shaft (122). The sleeve may be cut lengthwise with a sharp knife.
2. Thoroughly clean the shaft. Pay particular attention to the knurled area of the shaft under the sleeve.

**NOTE: The replacement sleeve will not have the same dimensions as the sleeve which was removed until it is mounted on the shaft and machined.**

3. Heat the replacement sleeve in a controlled oven at 550° F (288° C) for 40 minutes.



### CAUTION

**Do not heat the sleeve with an open flame — irreparable damage will occur to the sleeve.**



### WARNING

**The oven and sleeve are hot. Use insulated gloves to prevent burn injuries.**

4. Remove the sleeve from the oven.
5. Slide the sleeve onto the shaft immediately after removing it from the oven. Push the sleeve onto the shaft until the sleeve bottoms out on the shoulder of the shaft (Fig. VI-1). The hook end of the sleeve will extend beyond the knurled portion of the shaft.

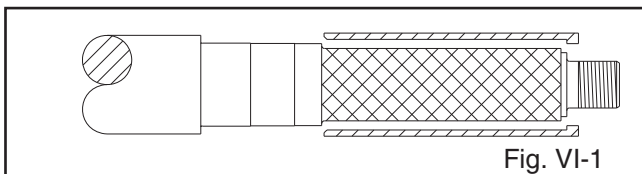

6. As the sleeve cools, it will shrink in length. Apply light pressure to keep the sleeve against the shaft shoulder. Maintain pressure until the hook portion of the sleeve seats itself against the shoulder under the hook (Fig. V-2).

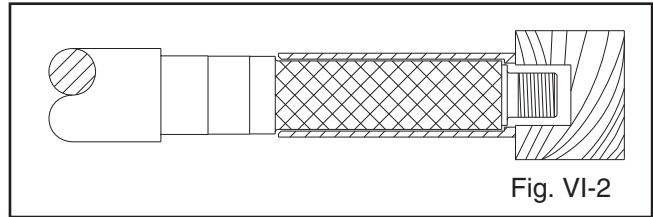

### CAUTION

**Care must be taken not to damage the end of the sleeve.**

7. Allow the shaft and sleeve to cool completely.

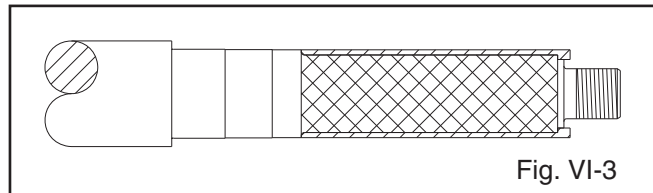

8. Machine the Teflon® sleeve to the dimensions and finish shown in *Table VI-1*.

Frame	Sleeve OD	Surface Finish
STX	1.375 / 1.373	16 μ in.
MTX	1.750 / 1.748	16 μ in.

9. Face off the sleeve shoulder even with and parallel to the shaft shoulder (Fig. VI-4).

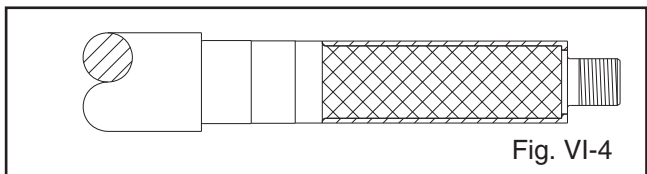



# APPENDIX VII-1

## Double Row Angular Contact Bearing Installation Instructions

1. Inspect the shaft (122) to ensure that it is clean, dimensionally correct, and is free of nicks, burrs, etc.
2. Lightly coat the bearing seating with a thin film of oil.
3. Remove the bearing (112) from its packaging.
4. Wipe the preservative from the bearing (112) bore and outer diameter.
5. Use an induction heater with a demagnetizing cycle to heat bearing (112) to an inner ring temperature of 230 °F (110 °C).



### WARNING

***Wear insulated gloves when using a bearing heater. Bearings will get hot and can cause physical injury.***

***NOTE: Regreasable bearing has a single shield. The outboard bearing is installed with shield toward impeller.***

7. Remove bearing locknut (136) after bearing (112) has cooled.
8. Place lockwasher (382) on shaft (122). Place tang of lockwasher in keyway of shaft.
9. Thread locknut (136) onto shaft (122). Tighten locknut one-eighth (1/8) to one-quarter (1/4) turn beyond snug. Bend any tang of lockwasher (382) into a slot of locknut.

***NOTE: Tighten locknut if necessary to align the closest tab of lockwasher with slot on locknut, but do not overtighten. See Table VII-1 for maximum locknut torque.***

6. Position the bearing (112) on the shaft (122) against the shoulder and snug the locknut (136) against the bearing until it is cool. The locknut prevents the bearing from moving away from the shaft shoulder as it cools.

**Table VII-1  
Maximum Bearing Locknut Torque**

Group	Bearing Size	Locknut Size	Torque Ft-Lb (Nm)
STX	5306	N-06	20 (27)
MTX	5309	N-09	50 (68)
XLT-X, X17	5313	N-13	140 (190)

8

**Table VII-2  
Maximum Bearing Locknut Torque**

Group	Bearing Size	Locknut Size	Maximum Torque Ft-Lb (N•m)
STX	7306	N-06	20 (27)
MTX	7309	N-09	50 (68)
LTX	7310	N-10	70 (95)
XLT-X, X17	7313	N-13	140 (190)



# APPENDIX VII-2

## Duplex Angular Contact Bearing Installation Instructions

1. Inspect the shaft (122) to ensure that it is clean, dimensionally correct, and is free of nicks, burrs, etc. (Fig. VII-1).

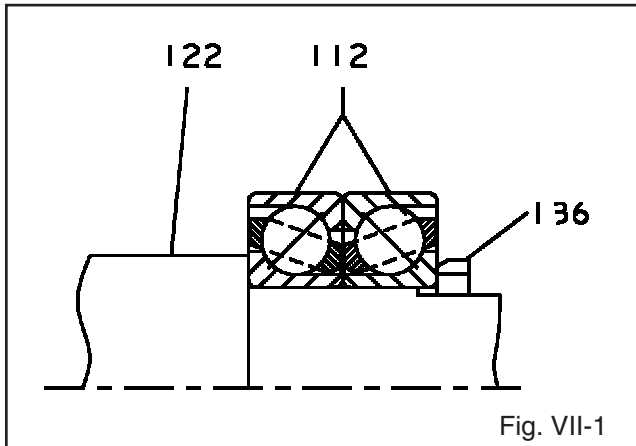

2. Lightly coat the bearing seating with a thin film of oil.
3. Remove the bearings (112) from their packaging.
4. Wipe the preservative from the bearing (112) bore and outer diameter.
5. Use an induction heater with a demagnetizing cycle to heat both bearings (112) to an inner ring temperature of 230 °F (110 °C).
6. Place both bearings (112) on the shaft (122) with the large outer races together (back to back).



### CAUTION

*Duplex bearings are mounted back to back. Make sure orientation of bearings is correct.*



### WARNING

*Wear insulated gloves when using a bearing heater. Bearings will get hot and can cause physical injury.*

7. Position the bearings (112) on the shaft (122) against the shoulder and snug the locknut (136) against the bearings until they are cool. The locknut prevents the bearings from moving away from the shaft shoulder as they cool. It is best to rotate the outer bearing rings relative to each other as they are placed on the shaft to assure good alignment.
8. Remove bearing locknut (136) after bearings (112) have cooled.
9. Place lockwasher (382) on shaft (122). Place tang of lockwasher in keyway of shaft. (Fig. VII-2).

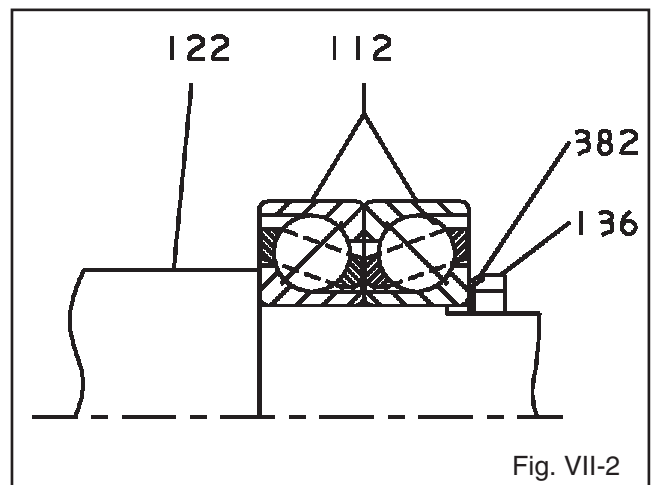

10. Thread locknut (136) onto shaft (122). Tighten locknut one-eighth (1/8) to one-quarter (1/4) turn beyond snug. Bend any tang of lockwasher (382) into a slot of locknut.

**NOTE:** *Tighten locknut if necessary to align the closest tab of lockwasher with slot on locknut, but do not overtighten. Refer to Table VII-2 for maximum locknut torque.*



# APPENDIX VIII

## INPRO Labyrinth Oil Seal Installation Instructions

### Description of Operation

The INRP VBXX-D<sup>®</sup> Labyrinth Oil Seal is specially designed to protect pump bearings from lubrication starvation as well as environmental contamination. The bearing is made up of three basic parts: the rotor (1), stator (2), and VBX<sup>®</sup> Ring (3). The rotor (1) fits over the shaft and is held in place by an elastomeric drive ring (4). The drive ring causes the rotor to turn with the shaft and provides a positive, static seal against the shaft. There is no metal-to-metal contact, therefore, no friction or wear concerns.

### Installation Procedures



#### CAUTION

*The INPRO VBX is a one piece design. Do not attempt to separate the rotor (1) from the stator (2) prior to or during installation.*

1. Assemble the power end per the instructions in Section 6 - Disassembly and Reassembly.



#### CAUTION

*The edges of the keyway can be sharp. Failure to cover the keyway with tape may result in a cut o-ring and a damaged seal.*

2. Wrap some electrical tape around the coupling end of the shaft to cover the keyway.

**NOTE:** *The smooth surface of the electrical tape provides an excellent surface to slide the rotor O-ring over.*

3. Lightly lube the shaft and rotor drive ring (4) with supplied lubricant.

**NOTE:** *Lubricant will aid in the installation process. If used, be sure the lubricant is compatible with the O-ring material and plant standards.*

4. Use an arbor press to install the outboard INPRO VBXX-D<sup>®</sup> into the bearing cover with the expulsion port (6) at the 6 o'clock position. Press it only as far as the beginning of the stator location ramp (9) and avoid angular misalignment. There is nominal 0.002" interference fit. Discard any residual material from the stator gasket (5).

#### For STX Units

5. Press the inboard seal over the shaft into the bearing frame as described in Step 4 above.

#### For All Other Units

5. Once the frame adapter is installed on the bearing frame, press the inboard seal over the shaft and into the adapter as described in Step 4 above.

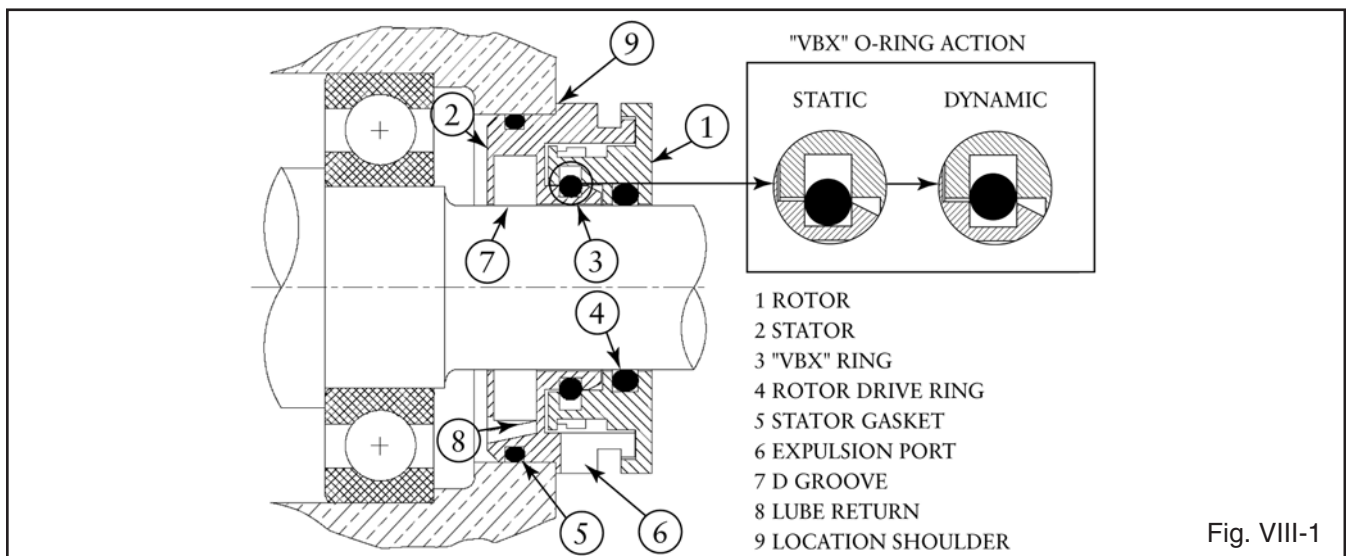

Fig. VIII-1

**NOTES**

Lined area for notes with multiple horizontal lines.









## HOW TO ORDER

When ordering parts call  
**1-800-446-8537**  
or your local ITT Goulds Representative

## EMERGENCY SERVICE

Emergency parts service is available  
24 hours/day, 365 days/year . . .  
Call 1-800-446-8537

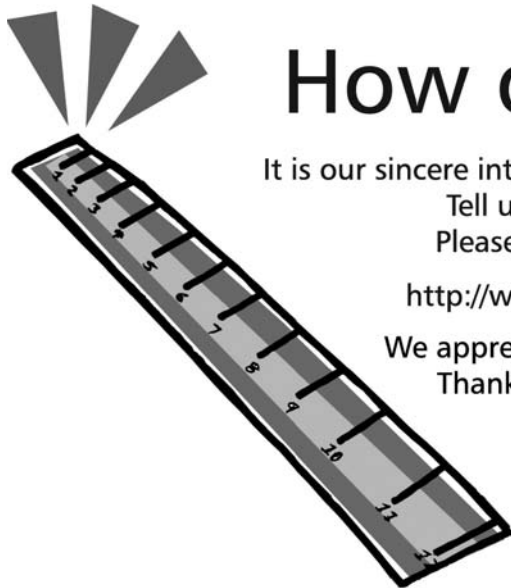

## How did we measure up?

It is our sincere intention to exceed our customer's expectations on every order.

Tell us whether we achieved our goal on your order.

Please take our customer satisfaction survey online at:

<http://www.ittindustrialproducts.com/feedbacksurvey.html>

We appreciate you taking the time to provide your feedback.

Thank you for buying ITT pumps, parts, and controls.

