

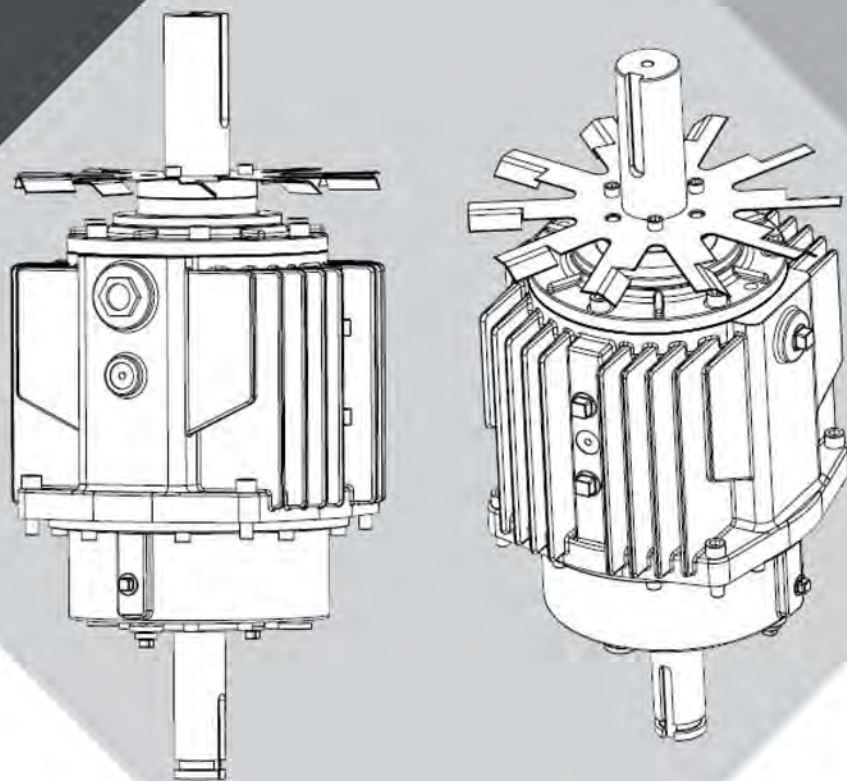

# Installation, Operation, and Maintenance Manual

Fan Cooled Thrust Pots FC-7314, FC-7318,  
FC-7324, FC-7330



**ITT**



---

# Foreword

This manual provides instructions for the Installation, Operation, and Maintenance of the Goulds Pumps Fan Cooled Thrust Pots. This manual must be read and understood before installation and start-up.

This instruction manual provides the necessary information to properly operate and maintain the fan cooled thrust pot included with your pump assembly. This manual does not cover the complete pump, and the original manuals furnished with the equipment must be referenced when servicing and maintaining the pump and all associated equipment. The design, materials, and workmanship incorporated in the construction of ITT Goulds pumps makes them capable of giving long, trouble-free service. The life and satisfactory service of any mechanical unit, however, is enhanced and extended by correct application, proper installation, periodic inspection, condition monitoring, and careful maintenance.

Goulds shall not be liable for physical injury, damage, or delays caused by a failure to observe the instructions for installation, operation, and maintenance contained in this manual.

These instructions do not cover all details or variations in equipment, nor provide every possible contingency to be met in connection with installation, operation or maintenance. Should further information be desired or should particular problems arise which are not covered sufficiently for the purchaser's purposes, the matter should be referred to the local Goulds Pumps Sales Office.



---

## WARNING:

⊠ When pumping unit is installed in a potentially explosive atmosphere, the instructions after the Ex symbol must be followed. Personal injury and/or equipment damage may occur if these instructions are not followed. If there is any question regarding these requirements or if the equipment is to be modified, please contact an ITT Goulds representative before proceeding.

---

The contents of this instruction manual shall not become part of or modify any prior or existing agreement, commitment or relationship. The sales contract contains the entire obligation of Goulds. The warranty contained in the contract between the parties is the sole warranty of Goulds. Any statements contained herein do not create new warranties or modify the existing warranty.

### **Warranty is valid only when genuine ITT Goulds parts are used.**

Use of the equipment on a service other than stated in the order will nullify the warranty, unless written approval is obtained in advance from ITT Goulds Pumps.

Supervision by an authorized ITT Goulds representative is recommended to assure proper installation. Additional manuals can be obtained by contacting your local ITT Goulds representative or by calling customer service center at 1-800-446-8537.

# Important Safety Reminder

*To: Our Valued Customers*

Goulds industrial pump components such as thrust pots will provide safe, trouble-free service when properly installed, maintained, and operated. We have an extensive network of experienced sales and service professionals to assist in maximizing your satisfaction with our products.

Safe operation and maintenance of Goulds equipment is an essential end-user responsibility. This Installation, Operation, and Maintenance Manual identifies specific safety risks that must be considered at all times during product life. Understanding and adhering to these safety warnings is mandatory to ensure personnel, property, and/or the environment will not be harmed. Adherence to these warnings alone, however, is not sufficient—it is anticipated that the end user will also comply with industry and corporate safety standards. Identifying and eliminating unsafe operating and maintenance practices is the responsibility of all individuals involved in the operation and maintenance of industrial equipment.

Specific to pumping equipment, two significant risks bear reinforcement above and beyond normal safety precautions. These risks are detailed below:

---



**WARNING:**

- Never operate a thrust pot without lubrication under any circumstances. Operation for a brief period of time under these conditions can cause unrepairable damage to the bearings and ultimately failure of the thrust pot assembly. All necessary measures must be taken by the end user to ensure this condition is avoided.
  - The thrust pot will come assembled in the driver support from the factory in most cases. If not, refer to factory for special installation instructions. However, the thrust pot will have to be removed from the driver support in order to replace the bearings during scheduled maintenance periods. Contact ITT authorized repair center for disassembly, repair and re-assembly of thrust pot. Dismantle and repair by unauthorized service center voids warranty.
- 

Please take the time to review and understand the safe installation and maintenance guidelines outlined in this manual.

# Table of Contents

<b>1 Safety</b> .....	<b>4</b>
1.1 Safety .....	4
1.1.1 Safety tips .....	4
1.1.2 Precaution Warnings .....	4
1.1.3 General Precautions .....	5
1.1.4 Explosion Prevention .....	5
<b>2 Introduction</b> .....	<b>7</b>
2.1 Introduction.....	7
2.1.1 Thrust pot .....	7
2.1.2 Thrust pot nomenclature .....	7
2.1.3 General definitions .....	8
2.1.4 Thrust pot operation .....	9
2.1.5 Cross section and parts list .....	11
2.1.6 Condition monitoring .....	12
<b>3 Lubrication</b> .....	<b>15</b>
3.1 Lubrication.....	15
3.1.1 Lubrication types .....	15
3.1.2 Lubrication procedure .....	15
3.1.3 Operating oil level .....	18
3.1.4 Proper thrust pot oil level .....	19
<b>4 Maintenance</b> .....	<b>21</b>
4.1 Maintenance.....	21
4.1.1 Preventative maintenance.....	21
4.1.2 Service intervals.....	21
<b>5 Disassembly</b> .....	<b>23</b>
5.1 Disassembly.....	23
5.1.1 Thrust pot removal .....	23
5.1.2 Thrust pot service.....	26
<b>6 Reassembly</b> .....	<b>27</b>
6.1 Reassembly.....	27
6.1.1 Install thrust pot in driver support.....	27
6.1.2 Install the cowling and accessories.....	28
6.1.3 Assemble the pump .....	31
<b>7 Local ITT Contacts</b> .....	<b>34</b>
A.1 Appendix.....	35

# 1 Safety

## 1.1 Safety

### 1.1.1 Safety tips

#### Safety apparel

- Insulated work gloves when handling hot bearings or using bearing heater
- Heavy work gloves when handling parts with sharp edges
- Safety glasses (with side shields) for eye protection, especially in machine shop areas
- Steel-toed shoes for foot protection when handling parts, heavy tools, etc.
- Other personal protective equipment to protect against hazardous/toxic fluids

#### Coupling guards

- Never operate any rotating components without a coupling guard properly installed

#### Connection points

- Never force any piping to make a connection
- Never force coupling halves onto shafts
- Use only fasteners of the proper size and material
- Ensure there are no missing fasteners
- Beware of corroded or loose fasteners

#### Operation

- Do not operate without the proper level of oil in the thrust pot
- Never operate a thrust pot dry, or without lubrication
- Never operate a thrust pot outside the range of operation

#### Maintenance Safety

- Always lock out power
- Use proper lifting and supporting equipment to prevent serious injury
- Observe proper decontamination procedures
- Know and follow company safety regulations
- Observe all cautions and warnings highlighted in thrust pot Operation and Maintenance Instructions
- Know and follow company safety regulations



#### **CAUTION:**

The information in this manual is intended to be used as a guide only. If you are in doubt, contact customer service center for specific information about your pump. See the pump nameplate and pump outline drawing for the correct impeller lift setting.

---

### 1.1.2 Precaution Warnings

The parts detailed in the manual are designed for safe and reliable operation when properly used and maintained in accordance with instructions in this manual. The components supplied contain devices

with rotating parts that can be hazardous. Operators and maintenance personnel must realize this and follow safety measures. ITT Industries Goulds Pumps shall not be liable for physical injury, damage or delays caused by a failure to observe the instructions in this manual. Refer to the Goulds Pumps Installation, Operation, and Maintenance Manuals for your specific pump model which contains more complete information about pump specific safety precautions.

Throughout this manual the words WARNING, CAUTION, ELECTRICAL, ATEX, and NOTE are used to indicate procedures or situations which require special operator attention. All text under each heading should be read and fully understood before performing any work on the pump and any associated equipment. Refer to the following examples:

**WARNING:**

Operating procedure, practice, etc. which, if not correctly followed, could result in personal injury or loss of life.

**CAUTION:**

Operating procedure, practice, etc. which, if not followed, could result in damage or destruction of equipment.

**WARNING:**

- Particular care must be taken when electrical power source to the equipment is energized.

⚠ If equipment is to be installed in a potentially explosive atmosphere and these procedures are not followed, personal injury or equipment damage from an explosion may result.

**NOTICE:**

Operating procedure, condition, etc. which are essential to observe.

## 1.1.3 General Precautions

### Warning

Personal injuries will result if procedures outlined in this manual are not followed.

- NEVER apply heat to remove thrust pot from driver support.
- NEVER use heat to disassemble pump components due to risk of explosion from trapped liquid.
- NEVER operate thrust pot without coupling guard(s) correctly installed.
- NEVER operate thrust pot beyond the rated conditions to which the pump was sold.
- NEVER start pump without oil in the thrust pot.
- ALWAYS lock out power to the driver before performing any maintenance.
- NEVER operate thrust pot without safety devices installed.
- DO NOT change conditions of service without approval of an authorized Goulds representative.

## 1.1.4 Explosion Prevention

### Ex

⚠ In order to reduce the possibility of accidental explosions in atmospheres containing explosive gases and/or dust, the instructions under the Ex symbol must be closely followed. Ex certification is a specification enforced in Europe for non-electrical and electrical equipment installed in Europe. The usefulness of

the Ex requirements is not limited to Europe. They are useful guidelines for equipment installed in any potentially explosive environment.

---



**WARNING:**

⚠ When pumping unit is installed in a potentially explosive atmosphere, the instructions after the Ex symbol must be followed. Personal injury and/or equipment damage may occur if these instructions are not followed. If there is any question regarding these requirements or if the equipment is to be modified, please contact a Goulds representative before proceeding.

---

**Ex: intended use**

The Ex conformance is only applicable when the pump unit is operated within its intended use. Operating, installing or maintaining the pump unit in any way that is not covered in this manual can cause serious personal injury or damage to the equipment. This includes any modification to the equipment or use of parts not provided by ITT/Goulds. If there is any question regarding the intended use of the equipment, please contact an ITT/Goulds representative before proceeding.



# 2 Introduction

## 2.1 Introduction

### 2.1.1 Thrust pot

A thrust pot is a self-contained bearing housing and is utilized when the electric motor is not designed to carry axial thrust created by the pump in the vertical direction. The thrust pot is installed inside a driver support and is located between the discharge of the pump and the motor.

The bearing housing contains two or three (depending on thrust pot model) heavy-duty angular contact bearings to absorb the pumps thrust load. One or two bearings (depending on thrust pot model) are positioned to carry thrust in the downward direction, and another bearing is positioned in the opposite direction to absorb any momentary upward thrust during upset conditions (ex. Start up operation). For reliability, the angular contact thrust bearings are oil splash lubricated.

A guide bearing is provided in the lower section of the thrust pot to minimize Guide movement during shaft alignment. For simplicity, the guide bearing is permanently lubricated.

A rigid coupling is used to connect the thrust pot shaft to the pump shaft. This rigid coupling can come in a variety of arrangements; typically an adjustable spacer type will be furnished. A flexible element coupling is required between the driver and the thrust pot shafts to accommodate misalignment.

### 2.1.2 Thrust pot nomenclature

ITT Goulds Pumps manufactures a total of sixteen different models of fan cooled thrust pots. There is a naming convention found with all fan cooled thrust pot based on the model size, and how many angular contact bearings are contained within the housing. Fan cooled thrust pot naming convention is as follows:

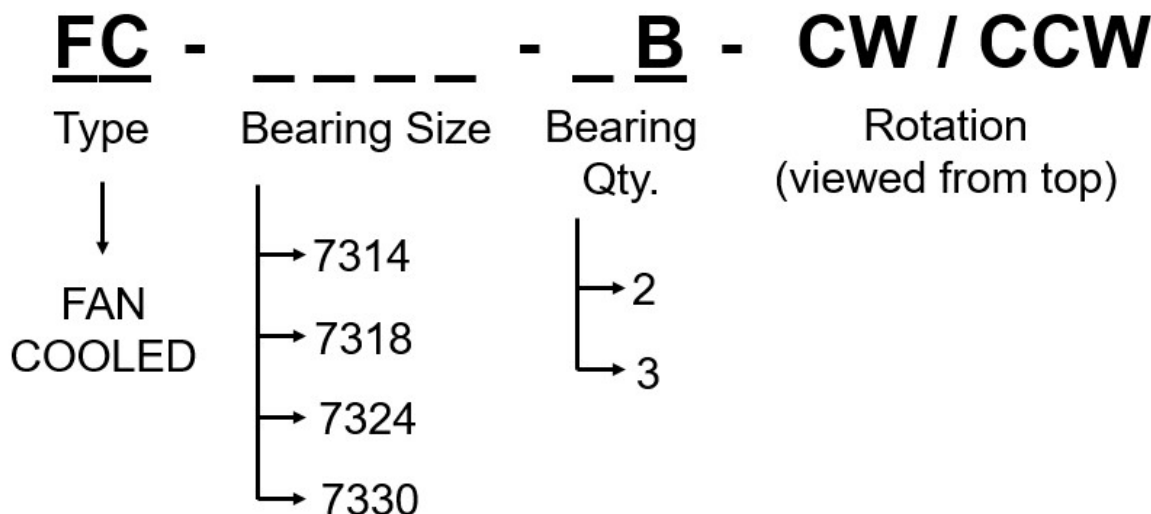

Examples –

- FC - 7318 - 2B - CW
- FC - 7324 - 3B - CCW

### 2.1.3 General definitions

The following terms are considered general pump knowledge, and may be used throughout the remainder of this manual.

#### Barrel (or can)

The barrel is flanged to support the weight of the pump and driver when full of liquid. The barrel may be installed in a foundation or open steel structure. The suction flange may be installed in the side of the barrel as in the VIC-L model.

#### Bowl assembly

The bowls are generally of flanged construction for accurate alignment and ease of assembly and disassembly. Impellers may be either open or enclosed, depending on the design requirements. A special first stage low NPSH impeller may be provided in certain applications.

#### Column

Flanged column construction provides positive shaft and bearing alignment, and also the ease of assembly and disassembly. Bearings are spaced to provide vibration-free operation below the shaft first critical speed in order to insure long bearing and shaft wear. The lineshaft is supported within the column by use of bearing retainers within the column assembly. These retainers are usually integrally fabricated for all diameters.

#### Cowling shroud

A cowling shroud is installed in the driver support over the thrust pot. The cowling shroud directs air flow over the fins of the fan cooled thrust pot. The cowling shroud has a fan guard on top when installed to prevent injury.

### **Discharge head**

The discharge head is designed to support the driver support, driver, and pump. The discharge head allows the driver support and driver to be aligned to the pump. Pump discharge connections as well as connections for seal flush or other bypass lines are included in the discharge head.

### **Driver / motor**

Where thrust pots are utilized, the most common type of driver supplied is a solid shaft electric motor.

### **Driver support**

The driver support is bolted to the top of the discharge head, and contains the thrust pot. The driver support is designed with large access openings for easy coupling maintenance. The driver support also contains intake ports for the flow of air produced by the fan from the thrust pot. All openings will be covered with guards to prevent injury.

## **2.1.4 Thrust pot operation**

### **How does it work**

Thrust pots contain angular contact bearings that absorb the axial down thrust produced by a pump during operation. Depending on the model, the thrust pot may have one or two bearings to absorb the axial down thrust. For low thrust applications, the top bearing may be replaced with a spacer piece, ultimately reducing the horsepower draw from the bearing housing and increasing the overall pump efficiency. The resultant force effectively pushes the bearings against the wall of the housing containing the bearings, thus absorbing the load (Refer to [Figure 1: Thrust pot operation on page 10](#)). One bearing is placed in the opposite direction to handle any momentary upward axial thrust. This condition may be present during start-up of the pump. The principle is the same as the opposing facing bearings for down thrust.

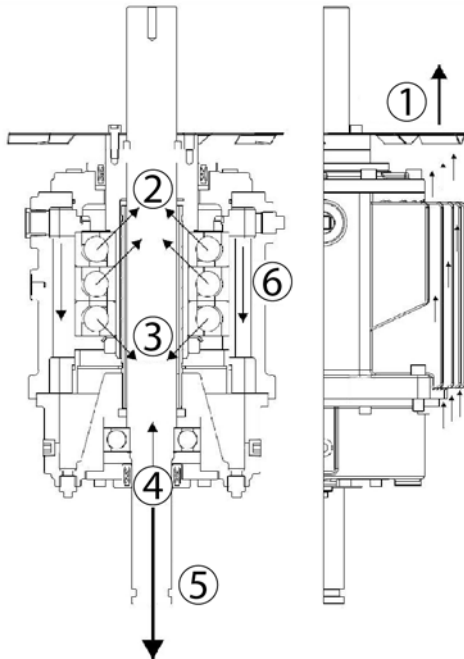

1. Air flow direction
2. Absorbed down thrust load
3. Absorbed up thrust load
4. Up thrust
5. Axial down thrust
6. Oil circulation path

**Figure 1: Thrust pot operation**

### Mechanical seal

The guide bearing holds the shaft in position during alignment. Precise alignment controls radial movement of the shaft and enables the use of mechanical shaft seals in the pump.

### How does it stay cool

As the angular contact bearings rotate and absorb the thrust load of a pump in operation, frictional heat is generated from all of the points of contact. Lubricating oil is splashed from the oil sump at the bottom of the thrust pot, through the bearings, and falls back down three oil circulation holes which are drilled on each side of the housing (total of 6 oil circulation holes). Oil temperature depends on a number of factors including (but not limited to): operating speed, ambient temperature, thrust load, amount of oil in thrust pot, oil viscosity, and oil cleanliness. When the housing temperature heats up to any temperature higher than ambient, the principle of radiant heat will start to remove heat energy from the thrust pot. The fan mounted to the top of the thrust pot pulls air from ports located near the mounting surface of the thrust pot, across fins attached to the bearing housing, and discharges the heated air out of ports located above the thrust pot. The discharge ports also act as an access point for the flexible element coupling between the thrust pot and driver. Air flow direction is shown above on [Figure 1: Thrust pot operation on page 10](#).

## 2.1.5 Cross section and parts list

**Table 1: Parts List**

Item No.	Description	Qty
1	Distribution cone	1
2	Fan	1
3	Locknut - bearing	1
4	Spindle	1
5	Oil retaining tube	1
6	Bearing isolator	1
7	Bearing isolator	1
8	Thrust ring	1
9	Retaining ring	1
10	Ring - spirol lock	1
11	Key square	1
12	Shim	3
13	Pipe plug, hex socket	2
14	Pipe plug	2
15	Pipe plug	4
16	Socket head capscrew	16
17	Socket head capscrew	6
18	Socket head capscrew	6
19	Socket head capscrew	4
20	Cover	1
21	Sight glass	1
22	Cover, lower housing	1
23	Gasket, lower housing	1
24	Gasket, lower housing cover	1
25	O-ring	1
26	Washer, locknut	1
27	Housing	1
28	Shaft	1
29	Bearing angular contact	2
30	Guide bearing	1
31	Housing, lower guide bearing	1

### NOTICE:

Always refer to your order specific cross sectional drawing, and your order specific outline drawing for complete thrust pot parts lists and information about the thrust pot model which has been provided with your equipment. [Figure 2: Typical fan cooled thrust pot cross section. Reference purposes only. on page 12](#) should be used as a general guide or quick reference for the parts included in the thrust pot. Refer to [Table 1: Parts List on page 11](#) for the corresponding parts per the balloons shown in [Figure 2: Typical fan cooled thrust pot cross section. Reference purposes only. on page 12](#).

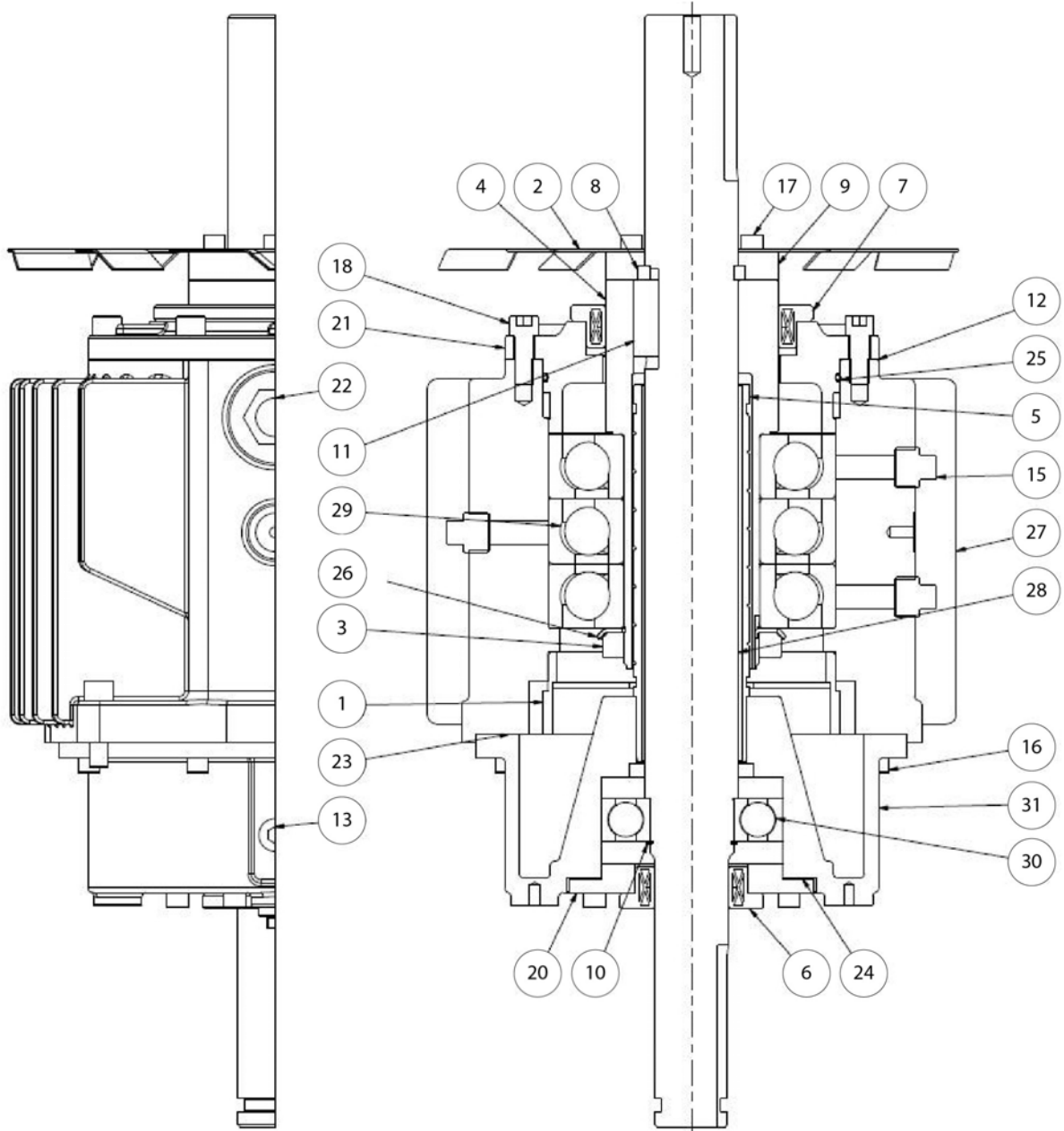

**Figure 2: Typical fan cooled thrust pot cross section. Reference purposes only.**

## 2.1.6 Condition monitoring

Provisions in the thrust pot have been included for various types of monitoring equipment. The extent of which the thrust pot operating conditions are monitored is completely up to the end user. Refer to [Figure 3: Provisions for condition monitoring on page 13](#) for typical connection points for various types of monitoring equipment. For questions regarding what type of monitoring devices have been included with your equipment refer to your project specific documentation. Some types of condition monitoring equipment are as follows:

### Vibration accelerometers

An accelerometer is a device that measures the vibration, or acceleration of motion relative to a fixed structure. The force caused by vibration or a change in motion is typically captured by a mass being

dampened by a spring. When the accelerometer experiences acceleration, the mass is displaced to the point that the spring is able to accelerate the mass at the same rate as the casing. The displacement is then measured to give the acceleration. API 610 recommends for vertical pumps with a thrust pot that the vibration reading be taken on the provisions provided on the thrust pot.

### Resistance thermometers (RTDs)

A resistance thermometer, also called a resistance temperature detector is a temperature sensor that exploits a predictable change in electrical resistance of some given materials with changing temperatures. Provisions for all three angular contact bearings (29) and for thrust pot oil temperature have been included in the thrust pot.

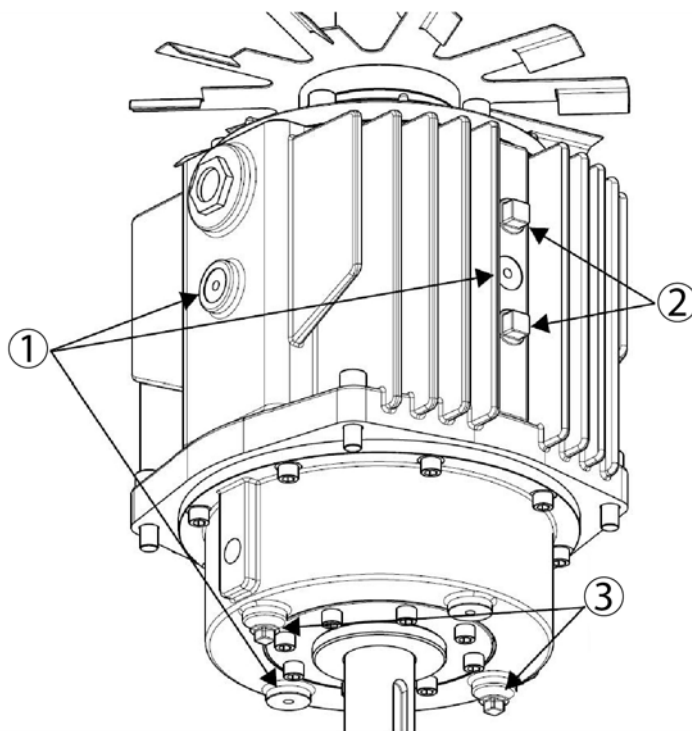

1. Provisions for vibration accelerators
2. Provisions for bearing temperature detection (not shown - middle bearing on back)
3. Provisions for oil temperature detection

**Figure 3: Provisions for condition monitoring**



#### WARNING:



If equipment is to be installed in a potentially explosive atmosphere and these procedures are not followed, personal injury or equipment damage from an explosion may result.

### Thrust pot operating temperatures

Stabilized bearing metal temperatures as measured on the bearing outer races at indicated locations (refer to [Figure 3: Provisions for condition monitoring on page 13](#)), or on all bearing housing outside surfaces shall be as follows:



- Normal Range: between 15.5°C | 60°F and 87.8°C | 190°F
- Alarm Level: between 88.3°C | 191°F and 93.3°C | 200°F

- Shutdown level: greater than 98.9°C | 210°F

### Thrust pot vibration levels

Stabilized overall vibration amplitudes as measured on the bearing housing at indicated locations (refer to [Figure 3: Provisions for condition monitoring on page 13](#) above) shall be as follows:



- Normal Range: not greater than 7.6 mm per second RMS | 0.30 inch per second RMS
- Alarm Level: between 7.9-10.2 mm per second RMS | 0.31 and 0.40 inch per second RMS
- Shutdown level: greater than 10.2 mm per second RMS | 0.40 inch per second RMS



# 3 Lubrication

## 3.1 Lubrication

### 3.1.1 Lubrication types

Goulds recommends that only ISO Grade VG 32, Synthetic Industrial Turbine Oil be used. These high quality synthetic oils are refined to remove unstable elements. They contain additives, including anti-oxidants, anti-foam agents for rapid separation of possible condensation, and corrosion inhibitors which adhere to the bearing surface and protect against rust. Use of these turbine type oils helps prevent excessive foaming, rusting, darkening, and assures excellent service in a wide range of operating temperatures. Refer to [Table 2: Recommended lubrication on page 15](#) for a list of recommended oils by manufacturer.



#### CAUTION:

Goulds does not recommend the use of detergent type oils (such as automotive oils) for lubrication of the thrust pots. Instead of allowing impurities to settle in the bottom of the oil reservoir sump, detergent type oils would suspend debris and allow contaminants to move freely through the circulating oil system where they could cause wear to the bearings. Use only oxidation-corrosion inhibited turbine oils of the viscosity recommended above.

**Table 2: Recommended lubrication**

Manufacturer	Description	ISO grade
AMSOIL	Synthetic anti-wear hydraulic oil	VG32
Chevron Texaco	Clarity ISO 32 hydraulic oil AW	VG32
ENERPAC	HF series hydraulic oil	VG32
Mobil	DTE 10 excel series hydraulic oil	VG32
Rosemead	R&O turbine oil	VG32
Royal Purple	High performance synthetic blend hydraulic oil	VG32
Shell	Tellus premium hydraulic oil	VG32

All recommended sythetic turbine oils above operate in an environment with an ambient temperature of -28.8°C to +54.4°C | -20°F to +130°F. For any environment outside specified temperature range, refer to your local Goulds Pumps sales office.

### 3.1.2 Lubrication procedure



#### WARNING:

Thrust Pots are shipped without lubricating oil, and must be filled prior to initial start-up. Failure to do so will result in severe damage to the thrust bearings rendering the thrust pot useless.

#### NOTICE:

For all parts referenced by an item number in parenthesis (XX), refer to the cross sectional drawing [Figure 2: Typical fan cooled thrust pot cross section](#). Reference purposes only. on [page 12](#) and [Table 1: Parts List on page 11](#), unless otherwise specified.

### Flush the thrust pot of contaminants

Many environmental variables are present during the shipping process. After the pump is installed but prior to commissioning, the thrust pot shall be flushed with clean oil to remove any contaminants which may be present. To flush the thrust pot, remove the pipe plug from the oil fill connection located outside of the driver support (Refer to [Figure 4: Driver support on page 16](#) for typical driver support arrangement). Also, remove one of the pipe plugs either from the tee connected to the external oil level gauge, or one of the two located on the lower housing. Refer to [Figure 5: Drain connections on page 17](#) for drain connections. Pour one of the recommended turbine oils (See [Table 2: Recommended lubrication on page 15](#)) into the oil fill connection until the oil is coming out of the drain connection for at least 20 seconds. If possible, rotate the thrust pot shaft by hand during the flushing process. Make sure the excess oil has been completely drained from the thrust pot. Install the pipe plug back into the drain connection used for flushing. The thrust pot is now ready to be filled with final lubrication oil.

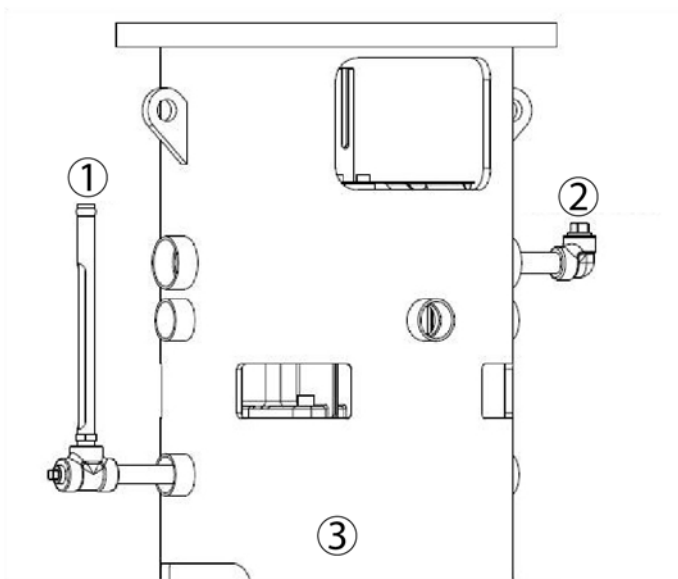

1. Oil level gauge
2. Oil fill connection
3. Driver support

**Figure 4: Driver support**

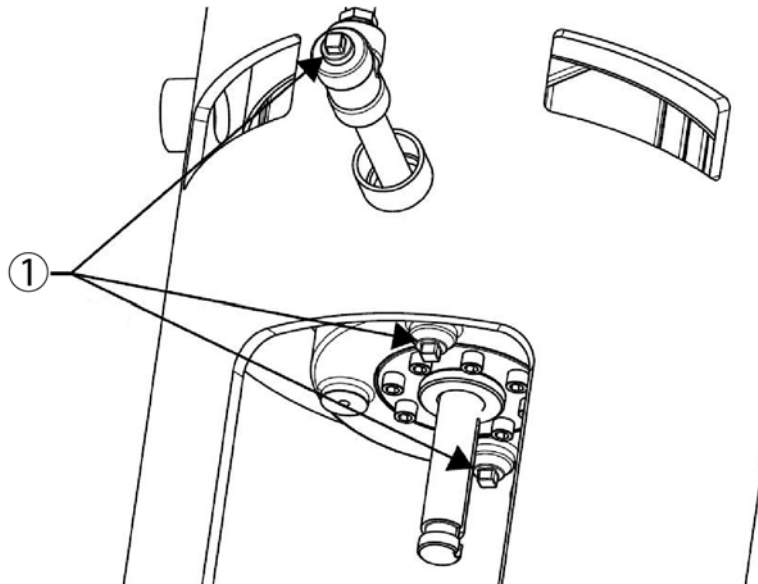

1. Drain connections

**Figure 5: Drain connections**

#### Thrust pot static oil level / initial oil fill



#### **WARNING:**

Do not use oil from flushing process for final lubrication. Contaminants can effect bearing life.

#### **NOTICE:**

The initial fill / static oil fill range is marked on the external oil level gauge from the factory.



#### **CAUTION:**

The oil fill range provided from the factory is considered the static fill range meaning that the pump is not in operation. Filling the thrust pot with oil for the initial fill or maintenance purposes shall only be performed when the pump is not in operation.

1. After flushing the thrust pot of any contaminants, be sure to reinstall all pipe plugs.
2. Remove the pipe plug from the oil fill connection (refer to [Figure 4: Driver support on page 16](#)) and pour one of the recommended oils (refer to [Table 2: Recommended lubrication on page 15](#)) into the thrust pot until the static level in the oil level gauge is between the static oil fill range. The two marks on the oil level gauge are considered the minimum and maximum static fill levels. Refer to [Figure 6: Oil level gauge on page 18](#). The recommended oil fill quantity per model size is detailed in [Table 3: Static oil fill quantities on page 18](#).

#### **NOTICE:**

[Table 3: Static oil fill quantities on page 18](#) shall be used as a guide and is intended to make sure enough clean oil is on hand at all times.

3. Reinstall pipe plug into the oil fill connection.

### Operating oil level

The operating oil level in the oil level gauge depends on factors such as rotating speed, temperature, and thrust pot model size. During operation, the oil level in the oil level gauge will be slightly lower (approx 6.3 – 38.1 mm | ¼" – 1.5") than the static fill level.

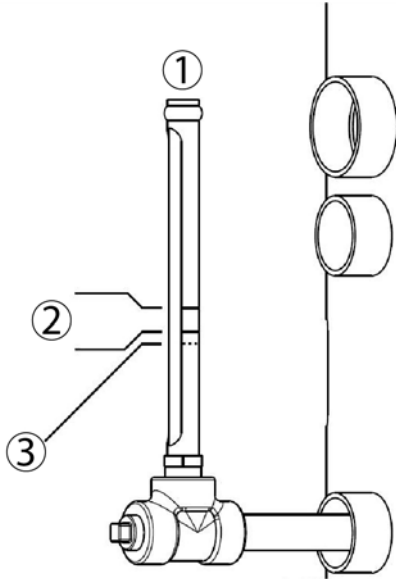

1. Oil level gauge
2. Static oil fill range marks by factory (pump not operating)
3. Operating oil level mark by customer during commissioning (pump operating)

**Figure 6: Oil level gauge**

### 3.1.3 Operating oil level

The operating oil level in the oil level gauge depends on factors such as rotating speed, temperature, and thrust pot model size. During operation, the oil level in the oil level gauge will be slightly lower (approx 6.3 – 38.1 mm | ¼" – 1.5") than the static fill level.



**WARNING:**

The operating level must be marked after start up of the pump. This will ensure the operating level is known, and the thrust pot does not mistakenly get filled with excess oil during operation.

**NOTICE:**

A nameplate will be provided on the driver support explaining oil level instructions. For an example of this nameplate, refer to [A.1 Appendix on page 35](#) of this manual.

**Table 3: Static oil fill quantities**

Thrust pot model	Fill quantity
F*-7314-*B	3-5 L   1.0-1.25 Gal
F*-7318-*B	6-8 L   1.5-2.0 Gal
F*-7324-*B	10-11 L   2.5-3.0 Gal

Thrust pot model	Fill quantity
F*-7330-*B	14-15 L   3.75-4.0 Gal

### 3.1.4 Proper thrust pot oil level

Setting the proper oil level in the thrust pot is critical to sound operation of the equipment. Visually, the oil circulation should look like wisps or splashes of oil being slung against the oil sight gauge (22). Some foam may be present as the oil in the thrust pot stabilizes during start up, but excessive foam should not fill the sight gauge. The sight gauge should not be filled completely with oil, as this is a sign of flooded operation. Refer to [Figure 7: Oil sight gauge on page 19](#) for a pictorial reference. The following guidelines can be followed to achieve the correct operating level.

1. The operating oil level in the oil level gauge will be slightly lower (approx. 6.3 – 38.1 mm | ¼" – 1.5") than the static fill range.



1. Oil sight gauge

**Figure 7: Oil sight gauge**

2. The visual sight glass (22) should be checked for circulation of oil during operation. The sight glass should not be filled with oil, as this is an indication of flooded operation. Splashing or sloshing of oil should be visible in the sight gauge. If the oil sight gauge is filled, then slowly drain a small amount of oil (about 60cc | 4-8 oz) and allow at least 1 minute for the oil level to stabilize. If the sight gauge is still filled with oil repeat this process until the proper level is achieved.



#### **WARNING:**

If no visible splashing or sloshing can be seen during operation, immediately add a small amount of oil until splashing is visible. This may be an indication of low oil, and the bearings may not be getting the proper lubrication.

3. If high bearing and oil temperatures are present, check the visual sight glass for any indication of circulation. This could be a result of flooded operation as described in step 2 (above). If no splashing or sloshing can be seen, immediately add a small amount of oil until splashing is visible. This may be an indication of low oil, and the bearings may not be getting the proper lubrication.
4. If the sight glass is completely filled with foam, this may be sign of contaminants in the oil. Some foam will be present at start up as the thrust pot oil temperature stabilizes, and depending on the operating speed of the thrust pot. Allow the thrust pot oil temperature to stabilize before checking for excessive foam. If so, flush the thrust pot with clean oil and resume operation.

5. After the proper level with stable operation is achieved, scribe a mark on the oil level gauge to indicate normal operating oil level.
6. As routine maintenance, add oil to the oil fill connection until the normal operating level has been achieved. Refer to [Figure 6: Oil level gauge on page 18](#) – normal operating oil level to be marked in the field after stable operation.

# 4 Maintenance

## 4.1 Maintenance

---

### NOTICE:

For all parts referenced by an item number in parenthesis (XX), refer to the cross sectional drawing [Figure 2: Typical fan cooled thrust pot cross section](#). Reference purposes only. on [page 12](#) and [Table 1: Parts List on page 11](#), unless otherwise specified.

---



### WARNING:

This equipment contains hazardous voltages, rotating parts and hot surfaces. Severe personal injury or property damage can result if safety instructions are not followed. Only qualified personnel should work on or around this equipment after becoming thoroughly familiar with all warnings, safety notices, and maintenance procedures contained herein. The successful and safe operation of this equipment is dependent upon proper handling, installation, operation and maintenance.

---



### CAUTION:

The use of unauthorized parts in the repair of the equipment, tampering by unqualified personnel, or removal or alteration of guards or conduit covers will result in dangerous conditions which can cause severe personal injury or equipment damage. Follow all safety instructions in this manual.

---

### 4.1.1 Preventative maintenance

It is a good practice to flush the oil reservoir before the first operation and at the time of oil changes to remove any grit particles in the oil reservoir sump. Use the same type of oil to flush the reservoir as specified for lubrication (Refer to [Table 2: Recommended lubrication on page 15](#)). Because of the special nature of the turbine oil recommended, it is wise to keep a supply on hand.

1. Remove drain plug (see [Figure 5: Drain connections on page 17](#)) before flushing. Flushing oil may be poured through oil fill connection after removing the pipe plug at the oil fill connection.
2. The proper oil level when the unit is not running shall be between the optimal oil fill ranges (Refer to [Figure 6: Oil level gauge on page 18](#)). Overfilling may result in overheating of the unit. During operation the oil level in the oil level gauge may be slightly lower (approx 6.3 – 38.1 mm | ¼" – 1.5") than the optimal oil fill range. Under no circumstances should the pump be operated when the oil in the oil level gauge is not at the required level.

---

### NOTICE:

To avoid oxidation of the anti-friction bearings during shutdown periods longer than one week, it is recommended to fill up the oil reservoir until the oil level gauge is completely filled so that the bearings remain completely immersed in oil. Before start-up do not forget to drain the excess oil to its required level.

---

### 4.1.2 Service intervals

Oil change depends on the severity of the environment. Generally speaking, when the oil in the visual sight glass (22) changes to a darkish brown colors it is time for an oil change. However, for a longer bearing life, it is recommended that the oil be changed every six months. Be sure to flush the oil reservoir

with each oil change. For approximate amount of oil needed, refer to [Table 3: Static oil fill quantities on page 18](#).

Systematic inspection of the thrust pot and its components should be made at regular intervals. The frequency required depends upon the operating conditions of the pump and its environment. Any deviation in performance or operation from what is expected can be traced to some specific cause. Variance from initial performance will indicate changing system conditions, wear, or impending breakdown of the unit.

Recommended oil change intervals for general industrial conditions should be considered every 2,000 operating hours, or 6 months. Angular contact bearing (29) L10 life intervals based in generally clean industrial service should be considered every 25,000 operating hours, or three years of operation. It is good practice to replace the guide bearing (30) during this time.



# 5 Disassembly

## 5.1 Disassembly

The following disassembly instructions should be used to disassemble the fan cooled thrust pots models, FC-7314 thru FC-7330. Supervision by an authorized ITT Goulds representative is recommended to assure proper installation. For additional information, contact your local ITT Goulds representative.

---

### NOTICE:

The following tools (supplied by others) will be needed to properly assemble the fan cooled thrust pot:

- |                                   |                                  |
|-----------------------------------|----------------------------------|
| 1. Crane / Hoist / Lift           | 5. Rubber Mallet                 |
| 2. Hydraulic/Mechanical Press     | 6. Typical Hand Tools            |
| 3. Bearing Induction Heating Tool | 7. Micrometer or Measuring Tools |
| 5. Allen Wrenches                 | 8. Dial Indicator                |
- 

---

### NOTICE:

For all parts referenced by an item number in parenthesis (XX), refer to the cross sectional drawing [Figure 2: Typical fan cooled thrust pot cross section](#). Reference purposes only. on [page 12](#) and [Table 1: Parts List on page 11](#) of this manual, unless otherwise specified.

---



---

### NOTICE:

For parts described in this manual which are not specified by an item number followed by parenthesis, refer to your Outline and Cross Sectional Drawing supplied with your equipment documentation.

---



---

### WARNING:

Only qualified personnel should work on or around this equipment after becoming thoroughly familiar with all warnings, safety notices, and maintenance procedures contained herein.

---



---

### CAUTION:

The use of unauthorized parts in the repair of the equipment, tampering by unqualified personnel, or removal or alteration of guards or conduit covers will result in dangerous conditions which can cause severe personal injury or equipment damage.

---

### 5.1.1 Thrust pot removal

#### 5.1.1.1 Prepare pump for disassembly

1. Shut down the pump.
  - a) Slowly close discharge valve.
  - b) Shut down and lock out power to the driver to prevent accidental rotation.
2. Isolate the pump from the suction and discharge piping.

- a) Make sure that the pump is isolated from the system and that pressure is relieved before any work is performed including: removing plugs, opening vent and drain valves, or disconnecting any piping.
- b) Always disconnect and lock out power to the driver before any work is performed. Failure to disconnect and lock out driver power will result in serious physical injury.



---

**WARNING:**

Crush Hazard. The unit and the components are heavy. Use proper lifting methods.

---



---

**WARNING:**

Lock out driver power to prevent electrical shock, accidental start-up, and physical injury.

---

3. Remove the electrical connections at the conduit box and label the electrical leads so they can be reassembled correctly.
4. If any monitoring devices have been installed on the pump, including RTD's or Thermocouples, remove them before proceeding with any work.



---

**WARNING:**

When handling hazardous and/or toxic fluids, proper personal protective equipment should be worn. If pump is being drained, precautions must be taken to prevent physical injury. Wear the proper personal protective equipment. Potential hazards include, but are not limited to, high temperature, flammable, acidic, caustic, explosive, and other risks. Pumpage must be handled and disposed of in conformance with applicable environmental regulations.

---



---

**WARNING:**

The pump must be properly vented through the discharge head / barrel vent connections. This is especially important for fluids with suction pressures close to their vapor pressures. Vent Piping must be continuously rising back to source so fluid cannot collect in the vent line.

---

### 5.1.1.2 Remove the lower coupling

1. Remove the coupling guard located in the window protecting the lower coupling assembly.

---

**NOTICE:**

If there is a mechanical seal, shaft sleeve must be properly isolated from the pump shaft in order to move onto the next step. Failure to do so will severely damage the mechanical seal. Refer to the manufacturer's instructions on how to properly isolate the mechanical seal from the pump shaft.

---

2. The coupling between the thrust pot shaft and discharge head shaft is typically an adjustable spacer type. This type of coupling is used on pumps furnished with a mechanical seal to permit servicing of the seal without removal of the driver. Remove the adjustable spacer coupling (typical) by loosening and removing the bolts from the thrust pot hub and from the pump hub.
3. Turn the adjusting plate so that the spacer has enough clearance to be removed.
4. Remove the thrust pot hub. Be sure to keep the thrust ring.

### 5.1.1.3 Remove the driver



**WARNING:**

Lock out driver power to prevent electrical shock, accidental start-up, and physical injury.

1. Remove the coupling guard located in the window protecting the flexible element coupling.
2. Remove the flexible element coupling. Refer to the manufacturer's instructions on how to properly remove the flexible element coupling.
3. Remove the capscrews securing the motor to the driver support stand.
4. Remove the driver. Refer to the manufacturer's instructions on how to properly handle and remove the driver.
5. Remove any motor adaptor plates which may restrict the removal of the thrust pot.



**WARNING:**

Be sure to have adequate lifting equipment rated to handle in excess of the driver weight.

6. Remove the driver. Refer to the manufacturer's instructions to properly secure and hoist the driver.
7. Drain the oil from the thrust pot. Refer to [Figure 5: Drain connections on page 17](#) for drain connections on the thrust pot.
8. Remove the oil level gauge located outside the driver support. Remove the pipe connecting the oil level gauge to the Lower Guide Bearing Housing (31). Refer to [Figure 4: Driver support on page 16](#) for oil level gauge position.
9. Remove the fan guard by removing the four capscrews connecting the guard to the cowling shroud.
10. Remove the cowling shroud off the thrust pot by sliding upward.
11. Remove the Fan (2). Refer to [Figure 8: Fan removal on page 25](#). The fan can be removed by unscrewing three Capscrews (17) connected to the Retaining Ring (9).

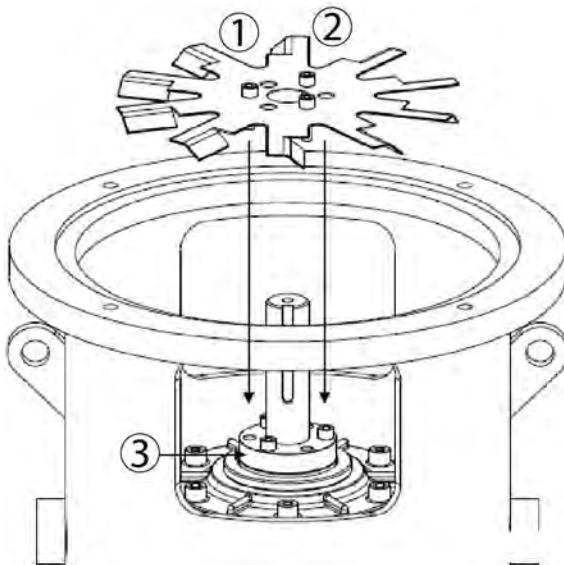

1. Capscrews (17)
2. Fan (2)
3. Retaining ring (9)

**Figure 8: Fan removal**

12. Remove the entire thrust pot assembly (less fan), and place on blocks (supplied by others) so that the thrust pot is in the vertical direction.

**NOTICE:**

Be sure to note the orientation of the thrust pot in the driver support. The thrust pot will have to be installed into the driver support in the same orientation of which it was removed. Failure to do so will misalign connections points for the oil level gauge, and fill tube not allowing the thrust pot to operate properly.

---

**5.1.2 Thrust pot service**

Contact ITT Goulds Pumps authorized service center to service the thrust pot.

# 6 Reassembly

## 6.1 Reassembly

The following assembly instructions should be used to assemble fan cooled thrust pots models, FC-7314 thru FC-7324. Supervision by an authorized ITT Goulds representative is recommended to assure proper installation. For additional information, contact your local ITT Goulds representative.

---

### NOTICE:

The following tools (supplied by others) will be needed to properly assemble the fan cooled thrust pot:

---

- |                                   |                                  |
|-----------------------------------|----------------------------------|
| 1. Crane / Hoist / Lift           | 5. Rubber Mallet                 |
| 2. Hydraulic/Mechanical Press     | 6. Typical Hand Tools            |
| 3. Bearing Induction Heating Tool | 7. Micrometer or Measuring Tools |
| 5. Allen Wrenches                 | 8. Dial Indicator                |
- 

### NOTICE:

For all parts referenced by an item number in parenthesis (XX), refer to the cross sectional drawing [Figure 2: Typical fan cooled thrust pot cross section](#). [Reference purposes only. on page 12](#) and [Table 1: Parts List on page 11](#) of this manual, unless otherwise specified.

---

### NOTICE:

For parts described in this manual which are not specified by an item number followed by parenthesis, refer to your Outline and Cross Sectional Drawing supplied with your equipment documentation.

---



### WARNING:

Only qualified personnel should work on or around this equipment after becoming thoroughly familiar with all warnings, safety notices, and maintenance procedures contained herein.

---



### CAUTION:

The use of unauthorized parts in the repair of the equipment, tampering by unqualified personnel, or removal or alteration of guards or conduit covers will result in dangerous conditions which can cause severe personal injury or equipment damage.

---

### 6.1.1 Install thrust pot in driver support

1. Screw an eyebolt (supplied by others) into the top of the shaft where the hole has been drilled and tapped. Using a crane or hoist, slowly lift the thrust pot and lower it into the driver support.
  2. Orient the thrust pot so that the Oil Sight Gauge (22) is aligned with the view port in the driver support.
- 

### NOTICE:

Driver supports may vary in design depending on the application. This manual cannot cover every configuration of driver supports. Orient the thrust pot the same way as it was removed from the driver support.

---

3. Secure the thrust pot to the driver support using four Capscrews (19).

### 6.1.2 Install the cowling and accessories

1. Install the Fan (2) onto the Retaining Ring (9). Secure the fan in place with the Capscrews (17). Refer to [Figure 9: Fan removal on page 28](#).

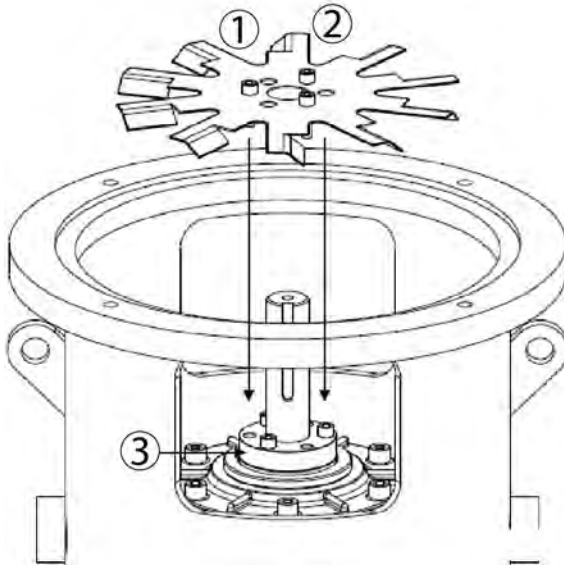

1. Capscrews (17)
2. Fan (2)
3. Retaining ring (9)

**Figure 9: Fan removal**

---

**NOTICE:**

It is recommended that the Fan (2) be installed on the thrust pot after it is installed in the driver support. This will minimize any damage being done to the fan while the thrust pot is being put back into the driver support.

---

**NOTICE:**

Fan (2) in [Figure 9: Fan removal on page 28](#) depicts the CCW rotation configuration as viewed from top. Regardless of rotational configuration of the thrust pot install fan with blades curved downwards.

---

2. Install the Oil Level Gauge into the thrust pot. The oil level gauge is typically located in the lowest port directly under the Oil Sight Gauge (22). The Oil Level Gauge Connection on the thrust pot is located in the side of the Lower Guide Bearing Housing (31). Refer to [Figure 10: Oil level gauge on page 29](#).

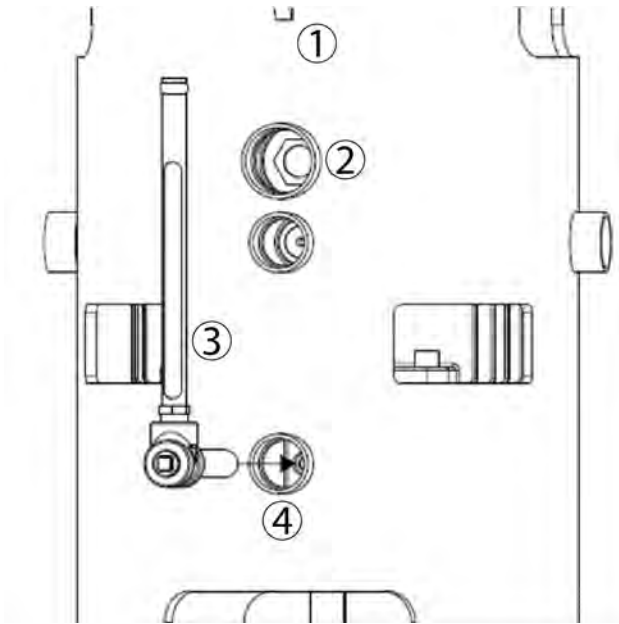

1. Driver support
2. Oil sight gauge (22)
3. Oil level gauge
4. Oil level gauge connection

**Figure 10: Oil level gauge**

3. Install the Cowling Shroud onto the Mounting Brackets as shown. Make sure to align the cowling shroud so that the two ports for the Oil Sight Gauge (22) and the accelerometer mount are in the correct position. Refer to [Figure 11: Cowling shroud on page 30](#).



1. Washers
2. Capscrews
3. Fan guard
4. Cowling shroud
5. Align points
6. Mounting brackets
7. Driver support

**Figure 11: Cowling shroud**

4. Install the Fan Guard. The fan guard can be installed using the capscrews and washers as shown. The holes in the cowling shroud are threaded therefore no bolting is required to secure the fan guard.
5. Install the Oil Fill Tube into the thrust pot. The oil fill connection is located in the port 180 degrees from the Oil Sight Gauge (22). It is typically the highest connection point in the driver support opposite of the oil sight gauge. Refer to [Figure 12: Oil fill tube on page 31](#).



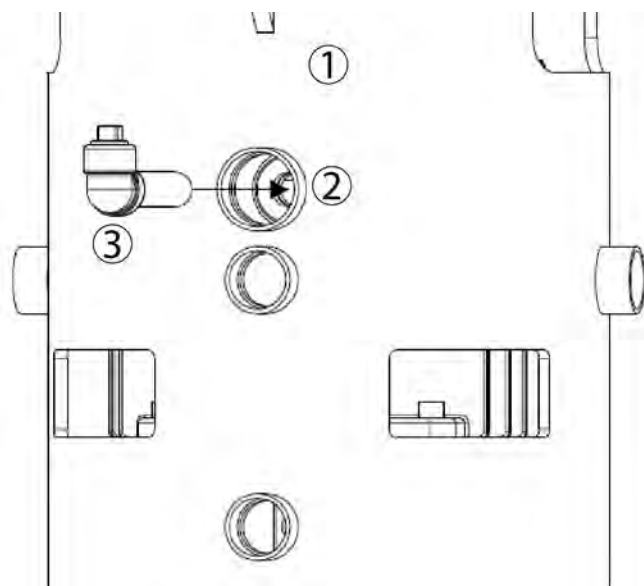

1. Driver support
2. Oil fill tube connection
3. Oil fill tube

**Figure 12: Oil fill tube**

6. Refer to [3.1 Lubrication on page 15](#) for thrust pot lubrication.



**WARNING:**

Remember to fill the thrust pot with oil before operation.

7. Install any external monitoring equipment, including RTD's or Thermocouples; install them on the associated components now.

## 6.1.3 Assemble the pump

### 6.1.3.1 Install the lower coupling

The coupling between the thrust pot shaft and discharge head shaft is typically an adjustable spacer type. This type of coupling is used on pumps furnished with a mechanical seal to permit servicing of the seal without removal of the driver.

1. Apply a thin film of oil on the pump key and insert key into headshaft keyway seat.
2. Gently lower pump hub of coupling onto headshaft.
3. Thread the adjusting plate onto the headshaft until flush with top of the headshaft.
4. Apply a thin film of oil to the thrust pot key and insert key into thrust pot shaft keyway seat. Place the thrust pot hub onto the thrust pot shaft and with key slide it up the drive shaft until the annular groove is exposed. Install split ring in the groove and slide driver hub down over the split ring to capture it.
5. Install spacer between the adjusting plate and thrust pot shaft hub. Secure with capscrews and hex nuts.

### 6.1.3.2 Impeller adjustment

Impeller adjustment is accomplished by turning the adjusting plate. The correct lift adjustment varies depending on the specific pump model. Refer to your Outline drawing submitted with your project documentation.

---

**NOTICE:**

Mechanical seal must not be secured to the shaft prior to impeller adjustment. The shaft must be able to move up or down within the seal assembly.

---

**NOTICE:**

For pumps handling liquids between -46°C to 93°C | -50°F to 200° F, impeller adjustments can be made under ambient conditions. For liquids in excess of this range, it is recommended that impeller adjustment be made after the pump surface temperature has reached equilibrium when charged with the pumpage. In those cases, where this is not feasible due to safety considerations or impossible due to external ice build up in cryogenic applications, refer to factory for specific instructions.

---

**NOTICE:**

 Improper impeller adjustment could cause contact between the rotating and stationary parts, resulting in a spark and heat generation.

---

Upon completion of setting the proper pump lift, seals using half dog setscrews can be tightened into position. Refer to the manufacturers instructions on properly setting the seal before starting any rotating equipment.

### 6.1.3.3 Install the driver



---

**WARNING:**



When installing in a potentially explosive environment, ensure that the motor is properly certified.

---



**WARNING:**

Do not work under a heavy suspended object unless there is a positive support and safe guards which will protect personnel should a hoist or sling fail.

---

1. Install any motor adaptor plates which could be installed on the top of the driver support.
2. Install the flexible element coupling between the thrust pot and driver. Refer to the Manufacturers' instructions to properly install the flexible element coupling.
3. Attach a sling to the lifting lugs of driver, hoist motor, inspect the mounting surface, register, and shaft extension, and clean these surfaces thoroughly. If any burrs are found, remove burrs with a smooth mill file, cleaning thoroughly afterward.
4. Orient the motor conduit box in the required position. Align the motor mounting holes with the mating tapped holes on the discharge head (or adaptor plate if applicable). Lower the motor until the registers engage and the motor rests on the discharge head. Secure motor with capscrews.

- 
5. On drivers having a non-reverse ratchet or pins, manually turn the driver shaft in the opposite direction to pump rotation (see arrow on pump nameplate) until the non-reverse ratchet or pins fully engage.
  6. Lubricate motor bearings in accordance with instructions given on lubrication plate attached to the motor case.

---

**NOTICE:**

Please read and follow the motor manufacturer's instructions before lubricating the motor bearings. Too much lubricant can cause the bearings to overheat and fail prematurely.

- 
7. Make electrical connections according to tagged leads or diagram attached to the motor. Motor must rotate in the same direction as pump rotates. See arrow on pump name plate. If motor does not rotate in desired direction, you can change the rotation by interchanging any two leads (for three phase only, for single phase motors see motor manufacturer's instructions.)
  8. Motor shaft end play adjustment: if required, motor shaft end play shall be checked with a dial indicator prior to connecting the pump coupling to the solid shaft motor. Consult the applicable motor manufacturers' instruction manual for detailed information on motor shaft end play.
  9. Install all the coupling guard(s) associated with all driver support windows.

**WARNING:**

Rotating components of the pump assembly must be covered with a suitable rigid guard to prevent injury to personnel.

---

# 7 Local ITT Contacts

# Appendix A

## A.1 Appendix

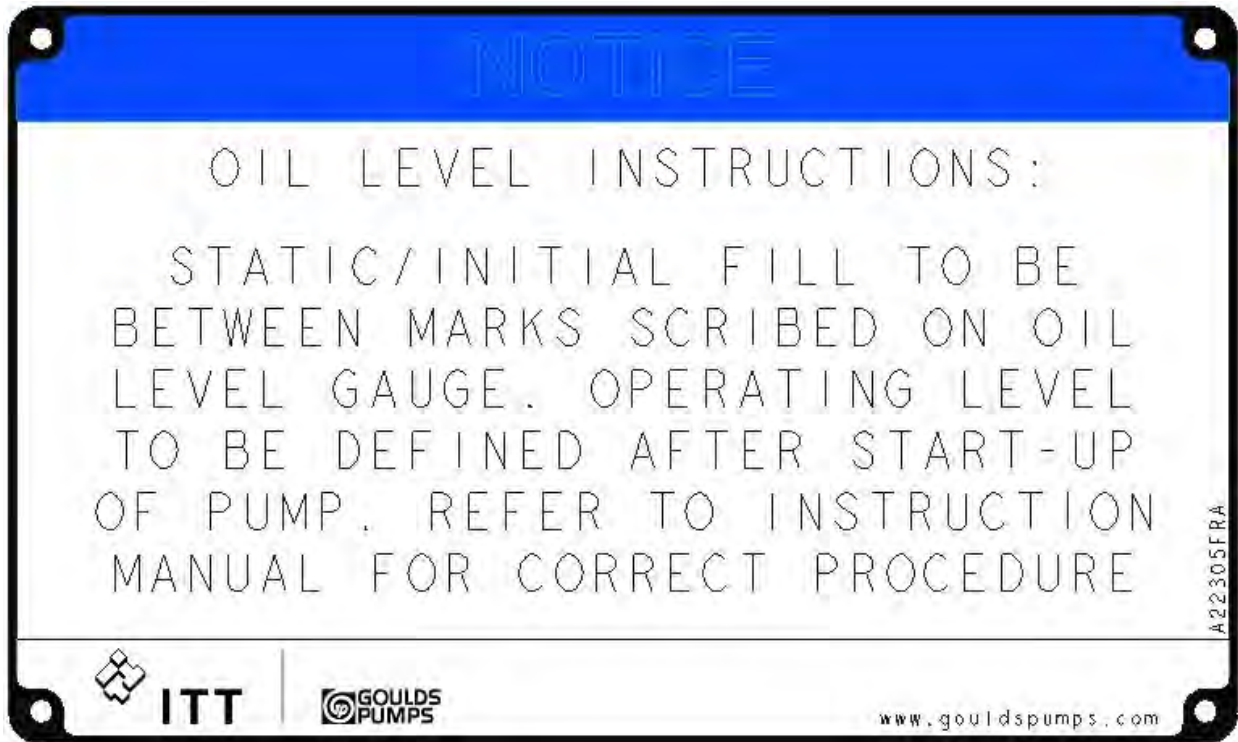

Figure 13: Example: Driver Support Oil Level Instructions Nameplate



**Figure 14: Example: Thrust Pot Name Plate**

**Visit our website for the latest version of  
this document and more information:**  
<http://www.gouldspumps.com>



Goulds Pumps Inc.  
240 Fall Street  
Seneca Falls, NY 13148  
USA

**Form IOM.FCTP.en-US.2019-11**