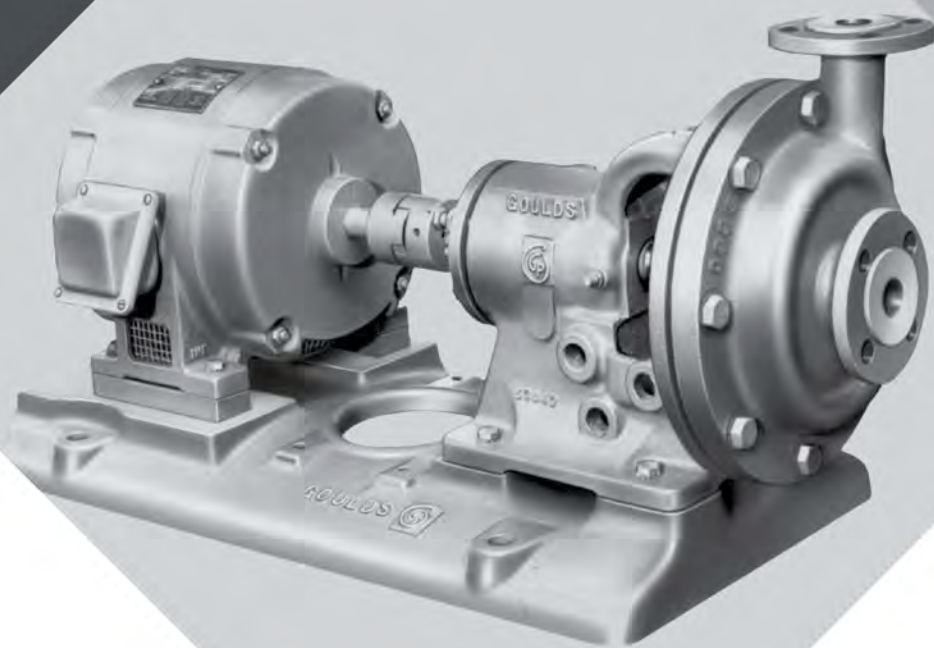


 **GOULDS PUMPS**

# Installation, Operation and Maintenance Instructions

3107



**ITT**



# Table of Contents

<b>1 Safety</b> .....	<b>3</b>
1.1 Important Safety Notice.....	3
1.2 Safety warnings.....	3
1.3 Safety.....	4
1.4 General precautions.....	5
1.5 ATEX Considerations and Intended Use.....	8
1.6 Parts.....	9
<b>2 Installation</b> .....	<b>10</b>
2.1 Description of units.....	10
2.2 Storage, uncrating & handling.....	10
2.3 Location.....	11
2.4 Installation - closecoupled and vertical pumps.....	11
2.5 Installation - horizontal pumps.....	12
2.6 Alignment procedures.....	13
2.7 Piping - general.....	17
2.8 Piping - suction.....	18
2.9 Piping - discharge.....	20
2.10	
Connection of piping.....	21
2.11 Rotation.....	21
2.12 Connection of coupling.....	21
<b>3 Preparation for operation</b> .....	<b>22</b>
3.1 Pump bearings.....	22
3.2	
Driver bearings and coupling.....	23
3.3 Stuffing boxes.....	23
3.4 Connection of sealing liquid or grease lubricator (packed box).....	25
3.5 Connection of cooling water piping.....	25
3.6 Connection of drain piping.....	26
3.7 Connection of equalizing piping.....	27
3.8 Impeller adjustment.....	27
<b>4 Starting pump</b> .....	<b>28</b>
4.1 Checking for free turning.....	28
4.2 Regulation of cooling and flushing liquids.....	28
4.3 Priming.....	28
4.4 Initial inspection after starting.....	31
4.5 Alignment - final.....	32
4.6 Doweling.....	32
<b>5 Operation</b> .....	<b>34</b>
5.1 Stuffing box.....	34
5.2 Operating at reduced capacities.....	34
5.3 Operating at reduced head.....	35
5.4 Operating with surge conditions in line.....	35
5.5 Operating under freezing conditions.....	35

<b>6 Maintenance</b> .....	<b>36</b>
6.1 Lubrication.....	36
6.2 Impeller adjustment.....	37
6.3 Disassembly of pump.....	37
6.4 Sectional View and Parts List.....	41
6.5 Inspection and Overhaul.....	42
6.6 Reassembly of pump.....	42
<b>7 Trouble check list</b> .....	<b>47</b>
7.1 No liquid delivered.....	47
7.2 Not enough liquid delivered.....	47
7.3 Not enough pressure.....	47
7.4 Pump works a while and then quits.....	48
7.5 Pump takes too much power.....	48
7.6 Pump leaks excessively at stuffing box.....	48
7.7 Pump is noisy or vibrates.....	49
7.8 High bearing temperature.....	49
<b>8 Care and Maintenance of Bearings</b> .....	<b>50</b>
8.1 Bearing temperatures.....	50
8.2 Bearing inspection.....	50
8.3 Cleaning of bearings.....	50
8.4 Bearing removal.....	51
8.5 Ball bearing installation.....	51
<b>9 Ordering of spare parts</b> .....	<b>53</b>
9.1 Spare parts.....	53
9.2 Instructions for ordering spare parts.....	54

# 1 Safety

## 1.1 Important Safety Notice

To: Our Valued Customers:

User safety is a major focus in the design of our products. Following the precautions outlined in this manual will minimize your risk of injury.

ITT Goulds pumps will provide safe, trouble-free service when properly installed, maintained, and operated.

Safe installation, operation, and maintenance of ITT Goulds Pumps equipment are an essential end user responsibility. This Pump Safety Manual identifies specific safety risks that must be considered at all times during product life. Understanding and adhering to these safety warnings is mandatory to ensure personnel, property, and/or the environment will not be harmed. Adherence to these warnings alone, however, is not sufficient — it is anticipated that the end user will also comply with industry and corporate safety standards. Identifying and eliminating unsafe installation, operating and maintenance practices is the responsibility of all individuals involved in the installation, operation, and maintenance of industrial equipment.

Please take the time to review and understand the safe installation, operation, and maintenance guidelines outlined in this Pump Safety Manual and the Instruction, Operation, and Maintenance (IOM) manual. Current manuals are available at <https://www.gouldspumps.com/en-US/Tools-and-Resources/Literature/> or by contacting your nearest Goulds Pumps sales representative.

These manuals must be read and understood before installation and start-up.

For additional information, contact your nearest Goulds Pumps sales representative or visit our Web site at <https://www.gouldspumps.com>

## 1.2 Safety warnings

Specific to pumping equipment, significant risks bear reinforcement above and beyond normal safety precautions.



---

**WARNING:**

A pump is a pressure vessel with rotating parts that can be hazardous. Any pressure vessel can explode, rupture, or discharge its contents if sufficiently over pressurized causing death, personal injury, property damage, and/or damage to the environment. All necessary measures must be taken to ensure over pressurization does not occur.

---



---

**WARNING:**

Operation of any pumping system with a blocked suction and discharge must be avoided in all cases. Operation, even for a brief period under these conditions, can cause superheating of enclosed pumpage and result in a violent explosion. All necessary measures must be taken by the end user to ensure this condition is avoided.

---



---

**WARNING:**

The pump may handle hazardous and/or toxic fluids. Care must be taken to identify the contents of the pump and eliminate the possibility of exposure, particularly if hazardous and/or toxic. Potential hazards include, but are not limited to, high temperature, flammable, acidic, caustic, explosive, and other risks.

---



**WARNING:**

Pumping equipment Instruction, Operation, and Maintenance manuals clearly identify accepted methods for disassembling pumping units. These methods must be adhered to. Specifically, applying heat to impellers and/or impeller retaining devices to aid in their removal is strictly forbidden. Trapped liquid can rapidly expand and result in a violent explosion and injury.

---

ITT Goulds Pumps will not accept responsibility for physical injury, damage, or delays caused by a failure to observe the instructions for installation, operation, and maintenance contained in this Pump Safety Manual or the current IOM available at <http://www.gouldspumps.com/literature>.

## 1.3 Safety

### Definitions

Throughout this manual the words Warning, Caution, Electrical, and ATEX are used to indicate where special operator attention is required.

Observe all Cautions and Warnings highlighted in the Pump Safety Manual and the IOM provided with your equipment.



**WARNING:**

Indicates a hazardous situation which, if not avoided, could result in death or serious injury. Example: Pump shall never be operated without coupling guard installed correctly.

---



**CAUTION:**

Indicates a hazardous situation which, if not avoided, could result in minor or moderate injury. Example: Throttling flow from the suction side may cause cavitation and pump damage.

---

### Electrical Hazard:



**WARNING:**

Indicates the possibility of electrical risks if directions are not followed. Example: Lock out driver power to prevent electric shock, accidental start-up, and physical injury.

---

### ATEX:



**WARNING:**

When installed in potentially explosive atmospheres, the instructions that follow the Ex symbol must be followed. Personal injury and/or equipment damage may occur if these instructions are not followed. If there is any question regarding these requirements or if the equipment is to be modified, please contact an ITT Goulds Pumps representative before proceeding. Example: Improper impeller adjustment could cause contact between the rotating and stationary parts, resulting in a spark and heat generation.

---






## 1.4 General precautions












### WARNING:

A pump is a pressure vessel with rotating parts that can be hazardous. Hazardous fluids may be contained by the pump including high temperature, flammable, acidic, caustic, explosive, and other risks. Operators and maintenance personnel must realize this and follow safety measures. Personal injuries will result if procedures outlined in this manual are not followed. ITT Goulds Pumps will not accept responsibility for physical injury, damage or delays caused by a failure to observe the instructions in this manual and the IOM provided with your equipment.








**Table 1: General Precautions**

WARNING		NEVER APPLY HEAT TO REMOVE IMPELLER. It may explode due to trapped liquid.
WARNING		NEVER use heat to disassemble pump due to risk of explosion from tapped liquid.
WARNING		NEVER operate pump without coupling guard correctly installed.
WARNING		NEVER run pump below recommended minimum flow when dry, or without prime.
WARNING		ALWAYS lock out power to the driver before performing pump maintenance.
WARNING		NEVER operate pump without safety devices installed.
WARNING		NEVER operate pump with discharge valve closed.
WARNING		NEVER operate pump with suction valve closed.
WARNING		DO NOT change service application without approval of an authorized ITT Goulds Pumps representative.
WARNING		<p>Safety Apparel:</p> <ul style="list-style-type: none"> <li>• Insulated work gloves when handling hot bearings or using bearing heater</li> <li>• Heavy work gloves when handling parts with sharp edges, especially impellers</li> <li>• Safety glasses (with side shields) for eye protection</li> <li>• Steel-toed shoes for foot protection when handling parts, heavy tools, etc.</li> <li>• Other personal protective equipment to protect against hazardous/toxic fluids</li> </ul>
WARNING		<p>Receiving:</p> <p>Assembled pumping units and their components are heavy. Failure to properly lift and support equipment can result in serious physical injury and/or</p>

1.4 General precautions

		equipment damage. Lift equipment only at specifically identified lifting points or as instructed in the current IOM. Current manuals are available at <a href="http://www.gouldspumps.com/literature_ioms.html">www.gouldspumps.com/literature_ioms.html</a> or from your local ITT Goulds Pumps sales representative. Note: Lifting devices (eyebolts, slings, spreaders, etc.) must be rated, selected, and used for the entire load being lifted.
WARNING		Alignment: Shaft alignment procedures must be followed to prevent catastrophic failure of drive components or unintended contact of rotating parts. Follow coupling manufacturer's coupling installation and operation procedures.
WARNING		Before beginning any alignment procedure, make sure driver power is locked out. Failure to lock out driver power will result in serious physical injury.
CAUTION		Piping: Never draw piping into place by forcing at the flanged connections of the pump. This may impose dangerous strains on the unit and cause misalignment between pump and driver. Pipe strain will adversely effect the operation of the pump resulting in physical injury and damage to the equipment.
WARNING		Flanged Connections: Use only fasteners of the proper size and material.
WARNING		Replace all corroded fasteners.
WARNING		Ensure all fasteners are properly tightened and there are no missing fasteners.
WARNING		Startup and Operation: When installing in a potentially explosive environment, please ensure that the motor is properly certified.
WARNING		Operating pump in reverse rotation may result in contact of metal parts, heat generation, and breach of containment.
WARNING		Lock out driver power to prevent accidental start-up and physical injury.
WARNING		The impeller clearance setting procedure must be followed. Improperly setting the clearance or not following any of the proper procedures can result in sparks, unexpected heat generation and equipment damage.
WARNING		If using a cartridge mechanical seal, the centering clips must be installed and set screws loosened prior to setting impeller clearance. Failure to do so could result in sparks, heat generation, and mechanical seal damage.
WARNING		The coupling used in an ATEX classified environment must be properly certified and must be constructed from a non-sparking material.
WARNING		Never operate a pump without coupling guard properly installed. Personal injury will occur if pump is run without coupling guard.



WARNING		Make sure to properly lubricate the bearings. Failure to do so may result in excess heat generation, sparks, and / or premature failure.
CAUTION		The mechanical seal used in an ATEX classified environment must be properly certified. Prior to start up, ensure all points of potential leakage of process fluid to the work environment are closed.
CAUTION		Never operate the pump without liquid supplied to mechanical seal. Running a mechanical seal dry, even for a few seconds, can cause seal damage and must be avoided. Physical injury can occur if mechanical seal fails.
WARNING		Never attempt to replace packing until the driver is properly locked out and the coupling spacer is removed.
WARNING		Dynamic seals are not allowed in an ATEX classified environment.
WARNING		DO NOT operate pump below minimum rated flows or with suction and/or discharge valve closed. These conditions may create an explosive hazard due to vaporization of pumpage and can quickly lead to pump failure and physical injury
WARNING		Ensure pump is isolated from system and pressure is relieved before disassembling pump, removing plugs, opening vent or drain valves, or disconnecting piping.
WARNING		Shutdown, Disassembly, and Reassembly: Pump components can be heavy. Proper methods of lifting must be employed to avoid physical injury and/or equipment damage. Steel toed shoes must be worn at all times.
WARNING		The pump may handle hazardous and/or toxic fluids. Observe proper decontamination procedures. Proper personal protective equipment should be worn. Precautions must be taken to prevent physical injury. Pumpage must be handled and disposed of in conformance with applicable environmental regulations.
WARNING		Operator must be aware of pumpage and safety precautions to prevent physical injury.
WARNING		Lock out driver power to prevent accidental startup and physical injury.
CAUTION		Allow all system and pump components to cool before handling them to prevent physical injury.
CAUTION		If pump is a Model NM3171, NM3196, 3198, 3298, V3298, SP3298, 4150, 4550, or 3107, there may be a risk of static electric discharge from plastic parts that are not properly grounded. If pumped fluid is non-conductive, pump should be drained and flushed with a conductive fluid under conditions that will not allow for a spark to be released to the atmosphere.
WARNING		Never apply heat to remove an impeller. The use of heat may cause an explosion due to trapped fluid, resulting in severe physical injury and property damage.
CAUTION		Wear heavy work gloves when handling impellers as sharp edges may cause physical injury.
CAUTION		Wear insulated gloves when using a bearing heater. Bearings will get hot and can cause physical injury.

WARNING		<p>Noise:</p> <p>Sound pressure levels may exceed 80 dbA in operating process plants. Clear visual warnings or other indicators should be available to those entering an area with unsafe noise levels. Personnel should wear appropriate hearing protection when working on or around any equipment, including pumps. Consider limiting personnel's exposure time to noise or, where possible, enclosing equipment to reduce noise. Local law may provide specific guidance regarding exposure of personnel to noise and when noise exposure reduction is required.</p>
WARNING		<p>Temperature:</p> <p>Equipment and piping surfaces may exceed 130°F (54°C) in operating process plants. Clear visual warnings or other indicators should alert personnel to surfaces that may reach a potentially unsafe temperature. Do not touch hot surfaces. Allow pumps operating at a high temperature to cool sufficiently before performing maintenance. If touching a hot surface cannot be avoided, personnel should wear appropriate gloves, clothing, and other protective gear as necessary. Local law may provide specific guidance regarding exposure of personnel to unsafe temperatures.</p>

## 1.5 ATEX Considerations and Intended Use

Special care must be taken in potentially explosive environments to ensure that the equipment is properly maintained. This includes but is not limited to:

### Description of ATEX

The ATEX directives are a specification enforced in Europe for electrical and non-electrical equipment installed in Europe. ATEX deals with the control of potentially explosive atmospheres and the standards of equipment and protective systems used within these atmospheres. The relevance of the ATEX requirements is not limited to Europe. You can apply these guidelines to equipment installed in any potentially explosive atmosphere.

### Guidelines for compliance

Compliance is fulfilled only when you operate the unit within its intended use. Do not change the conditions of the service without the approval of an ITT representative. When you install or maintain explosion proof products, always comply with the directive and applicable standards (for example, IEC/EN 60079-14).

1. Monitoring the and liquid end temperature.
2. Maintaining proper bearing lubrication.
3. Ensuring that the pump is operated in the intended hydraulic range.

The ATEX conformance is only applicable when the pump unit is operated within its intended use. Operating, installing or maintaining the pump unit in any way that is not covered in the Instruction, Operation, and Maintenance manual (IOM) can cause serious personal injury or damage to the equipment. This includes any modification to the equipment or use of parts not provided by ITT Goulds Pumps. If there is any question regarding the intended use of the equipment, please contact an ITT Goulds representative before proceeding.

Current IOMs are available at <https://www.gouldspumps.com/en-US/Tools-and-Resources/Literature/IOMs/> or from your local ITT Goulds Pumps Sales representative.

All pumping unit (pump, seal, coupling, motor and pump accessories) certified for use in an ATEX classified environment, are identified by an ATEX tag secured to the pump or the on which it is mounted. A typical tag would look like this:



**Figure 1: Typical ATEX pump nameplate**

**Table 2: Temperature class definitions**

Code	Maximum permissible pumpage temperature in °C   °F	Minimum permissible pumpage temperature in °C   °F
T1	450   842	372   700
T2	300   572	277   530
T3	200   392	177   350
T4	135   275	113   235
T5	100   212	Option not available
T6	85   185	Option not available

The code classification marked on the equipment must be in accordance with the specified area where the equipment will be installed. If it is not, do not operate the equipment and contact your ITT Goulds Pumps sales representative before proceeding.

The code classification marked on the equipment must be in accordance with the specified area where the equipment will be installed. If it is not, do not operate the equipment and contact your ITT Goulds Pumps sales representative before proceeding.

## 1.6 Parts



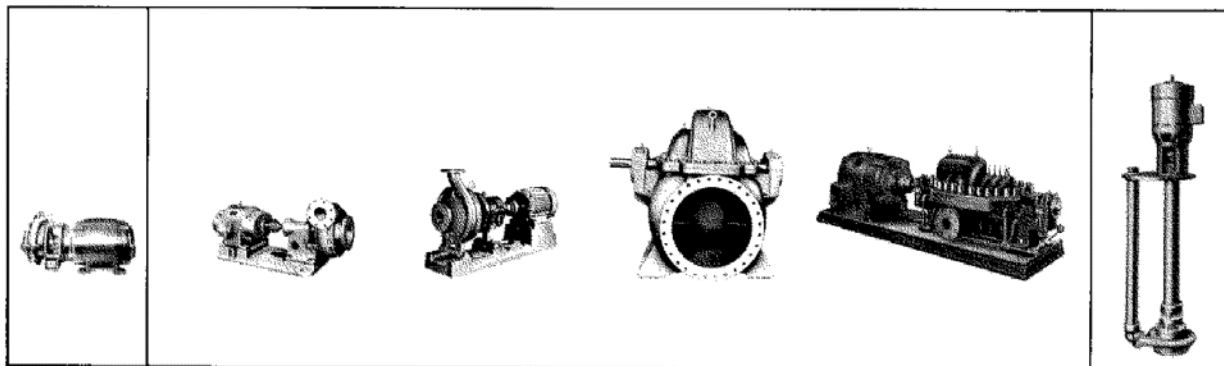
The use of genuine Goulds parts will provide the safest and most reliable operation of your pump. ITT Goulds Pumps ISO certification and quality control procedures ensure the parts are manufactured to the highest quality and safety levels.

Please contact your local Goulds representative for details on genuine Goulds parts.

## 2 Installation

### 2.1 Description of units

Reference is made to several different types of pumps in the following text. To enable the reader to associate these terms to his particular unit, photographs of typical units with an identifying description are shown below.



### 2.2 Storage, uncrating & handling

#### Storage

Goolds normal domestic storage preparation is suit able for protecting the pump during shipment in covered trucks. It also provides protection during covered storage at the jobsite, and for a short period between installation and start-up.

If the pump is to be idle and exposed to the elements for an extended period, either before or after installation, special precautions are required. One approach is to provide special preservatives and wrapping before shipment. However, after installation, the protective wrappings will have been removed. Therefore, application of preservatives after installation is considered good practice. The driver and coupling manufacturers should be contacted for recommendations on preservations and protection procedures.

It is considered good practice to rotate the shaft on pumps which contain ball or roller bearings approximately 30° every few weeks.

#### Uncrating

Care should be taken when uncrating pumps. If shipment is not delivered in good order and in accordance with the Bill-of-Lading, note the damage or shortage on both receipt and freight bill. Make any claims to the transportation company promptly.

Instruction sheets on various components as well as the Instruction Book for the pump are included in the shipment. Do not discard!

#### Handling

Care should be used in moving pumps. Pumps should not be hoisted by eyebolts. These eyebolts are used for removing upper half casings or back pull out assemblies for maintenance and inspection. Bedplate mounted units should be slung under bedplate (under pump and driver).

## 2.3 Location

Pumping unit should be placed as close as practical to the source of supply. Floor space and head room allotted to the unit must be sufficient for inspection and maintenance. Be sure to allow for crane or hoist service. On horizontally split case pumps, always allow sufficient head room to remove the upper half casing.

## 2.4 Installation - closecoupled and vertical pumps

### Close-coupled

A close-coupled pump may be mounted horizontally or in a vertical position provided motor is above pump. The unit should be bolted to a concrete foundation or an adequately supported structure, substantial enough to absorb any vibration and to form a permanent rigid support for the unit. All units have hold-down bolt holes in the motor feet and pump/adapter feet. Depending upon the motor frame, the pump or adapter feet may be higher or lower than the motor feet. Shim as required, then bolt all feet securely to support or foundation. Since the pump is mounted on the motor, permanent alignment is "built in". No subsequent alignment is necessary.

### Vertical

Vertical pumps may be mounted directly on a pit, using either the pump support plate only or in conjunction with a pit or tank cover. The units are shipped completely assembled except for motor, pit cover (if any), and float controls. Check all bolts and nuts on the entire unit to make sure they are securely tightened. Connect float and controls as shown on [6.4 Sectional View and Parts List on page 41](#).

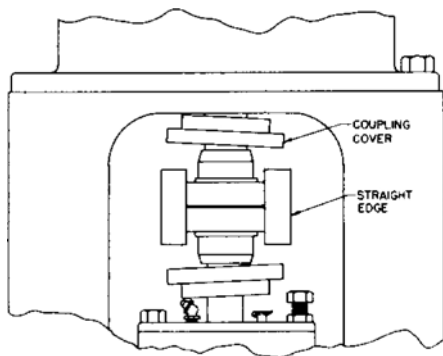
Installation must be done with care to avoid damage and ensure proper operation. It is recommended that a man be stationed inside the pit, whenever possible, to assist in the initial installation.

Lower the assembled pump (less motor) carefully into the pit. Guide unit carefully so that it does not strike sides of pit. When unit is in place, level the support plate. Shim under support plate as required. Pump must hang perfectly vertical to avoid placing a bending stress on the unit.

The support plate should be bolted to an adequately supported structure, substantial enough to absorb any vibration and to form a permanent, rigid support for the unit.

Place motor on motor support and tighten bolts (with lock washers) snugly.

Alignment of the coupling is of extreme importance for trouble-free mechanical operation. Check for alignment by laying a straight edge across coupling hubs at four points 90° apart. See Fig. 2. When the straight edge rests evenly at all four points, the coupling is aligned.



**Figure 2:**

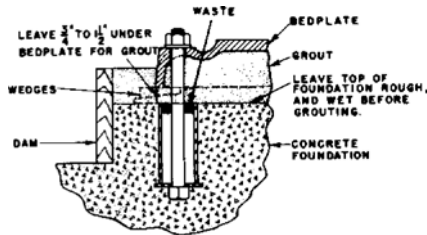
The machined faces of the motor support and motor will provide angular alignment. However, any foreign material or burrs on the surface will destroy this alignment. Make sure surfaces are clean and smooth.

## 2.5 Installation - horizontal pumps

Bedplate mounted units are normally mounted on a concrete foundation of liberal thickness poured on a solid footing, using a one-three-five mix. The foundation should be substantial in order to absorb any vibration and to form a permanent, rigid support for the pumping unit.

1. The location and size of foundation bolts are shown on the outline assembly drawing supplied for the unit.
2. When unit is mounted on a concrete foundation, each foundation bolt should be installed with a pipe sleeve around it to allow for adjustment.

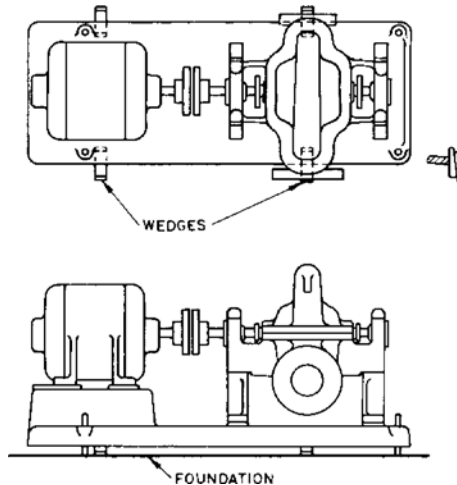
The I. D. of the sleeve should be  $2\frac{1}{2}$ -3 times the bolt diameter. Place a washer between the bolt head and sleeve to hold bolts. See Fig. 3.



**Figure 3:**

Stuff waste around bolts to prevent concrete from entering between bolt and sleeve. Bolts should be of sufficient length so that they project through the nuts approximately  $\frac{1}{4}$ " after allowance has been made for grouting, bedplate thickness, and nut thickness.

3. Put the unit in place on wedges. The wedges should be placed at four points as shown in Fig. 4. Some long installations may require additional wedges near the middle of the bedplate.



**Figure 4:**

4. Disconnect coupling between pump and driver.

---

**NOTICE:**

"Spider-Insert" couplings, as shown in Fig. 5, need not be disconnected.

---



**Figure 5:**

5. By adjustment of wedges, bring the bedplate to an approximate level and provide the proper distance above the foundation for grouting ( $\frac{3}{4}$ " to  $1\frac{1}{2}$ "). Level or plumb the suction and discharge flanges. Bring pump and motor shafts into reasonable alignment making absolutely certain that motor shaft is not above pump shaft or if it is, that there is a sufficient thickness of shims under the motor feet to allow for adjustment during alignment
6. Tighten foundation bolts, but only finger tight. Maintain the level of the bedplate.

---

**NOTICE:**

Final tightening is done after pump is grouted and grout has set at least 48 hours.

7. Build wood dam around foundation as shown in Fig, 3, and thoroughly wet top surface of foundation. Pour grout in hole provided in top of bedplate. Use of non-shrink grout is recommended. Grout should be thin enough to flow out under the bedplate but not so wet that sand and cement will separate. Grout should be puddled continuously as it is poured to expel the air and completely fill the space under the bedplate to the level of the grout hole. Strike along top of dam with trowel to give a neat finished appearance. Allow grout to harden at least 48 hours.
8. Tighten foundation bolts.
9. Tighten pump hold-down bolts.

## 2.6 Alignment procedures

### General

Alignment of the pump and driver is of extreme importance for trouble-free mechanical operation. The following are suggested steps to establish the initial alignment of the unit.

---

**NOTICE:**

This is an initial alignment. The final alignment is done after the unit has been run under actual operating conditions. The final alignment procedure is outlined in [4.5 Alignment - final on page 32](#) and must be followed. Make sure motor starting switch is locked out to prevent accidental rotation.

---

Any coupling manufacturer's instruction sheets, sent with the pump, should be studied and used when installing, aligning, or servicing coupling. Note that coupling hubs are not necessarily mounted flush with the shaft ends.

If instructions are not available, the following procedure may be used. The procedure is given for two basic coupling types:

1. Flexible Coupling - Normally furnished on all units except back pull-out. Normally not assembled (except spider-insert type which are pre-assembled).
2. Flexible Spacer Coupling - Furnished as standard on all back pull-out units. Contains a removable spacer piece located between coupling hubs.

**NOTICE:**

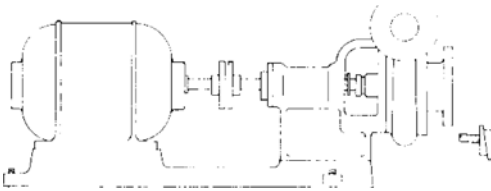
Alignment in one direction may alter alignment in another. Check through each alignment procedure after making any alignment alteration.

**Parallel alignment**

Unit is in parallel misalignment when the shaft axes are parallel but not concentric. Shift driver as required.

In order to obtain vertical parallel alignment under actual operating conditions, the driver shaft may have to be set higher or lower (using thin shim stock) than the pump shaft due to differences in expansion rates. Pump expansion rates vary with pump design. The following is a suggested cold setting for motor driven units:

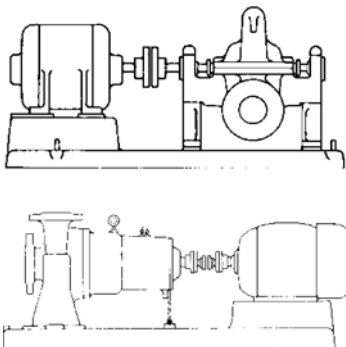
**Frame mounted units**



**Figure 6: Frame mounted units**

Pumpage Temperature Above Ambient Temperature	Set
Above Ambient Temperature	Motor Shaft
Ambient	.004" - .006" Low
100°F	.002" - .004" Low
200°F	.000" - .002" Low
300°F	.000" - .002" High

**Pedestal mounted units**

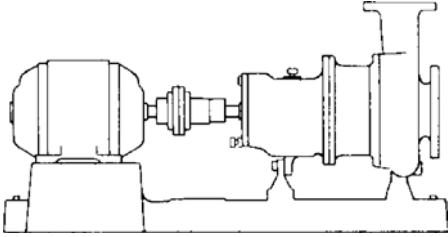


**Figure 7: Pedestal mounted units**

Set motor shaft .002" - .004" low regardless of pumpage temperature.

**Casing Mounted units**





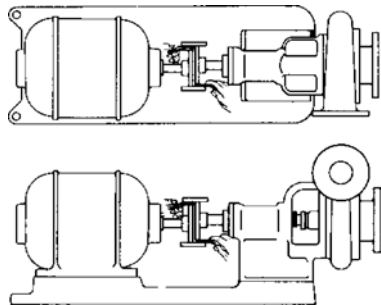
**Figure 8: Casing mounted units**

Pumpage temperature	Set
Above ambient	Motor
Temperature	Shaft
Ambient	.002" - .004" Low
100°F	.000" - .002" High
200°F	.004" - .006" High
300°F	.008" - .010" High
400°F	.012" - .014" High
500°F	.016" - .018" High

To check parallel alignment

1. Flexible couplings:

Place a straight edge across both coupling hubs at four points 90° apart. The unit will be in parallel alignment when the straight edge rests evenly on both halves. See Fig. 9.



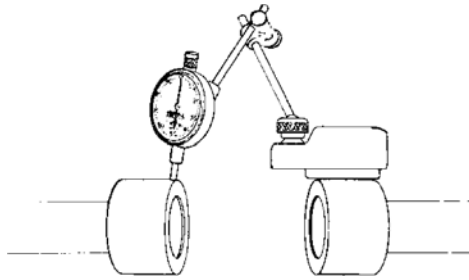
**Figure 9: Flexible couplings**

2. "Spider-Insert" Couplings

Place a straight edge across both coupling hubs at four points 90° apart. The unit will be in parallel alignment when the straight edge rests evenly on both halves. See Fig. 9.

3. Flexible Spacer Couplings

Place a dial indicator on one hub and rotate that hub 360° while taking readings on the outside diameter of the other hub. When indicator does not deflect more than .002" total, parallel alignment is achieved. See Fig. 10.



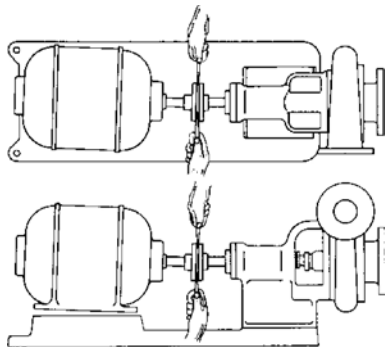
**Figure 10: Dial indicator**

**Angular alignment**

Unit is in angular misalignment when the shaft axes are concentric, but not parallel. Shim unit as required.

1. Flexible Couplings

The normal gap (distance between coupling halves) is approximately 1/2". However, the coupling manufacturer's instructions should be followed. Insert a feeler or taper gauge at 90° intervals on the circumference of the hubs. When the gap is identical within .002", the unit is in angular alignment. See Fig. 11.

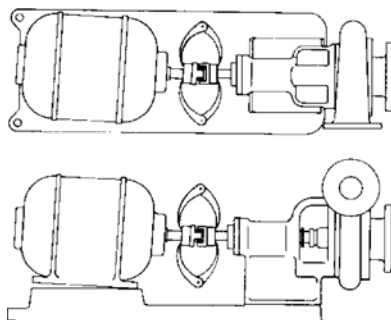


**Figure 11:**

2.

Spider-Insert Couplings

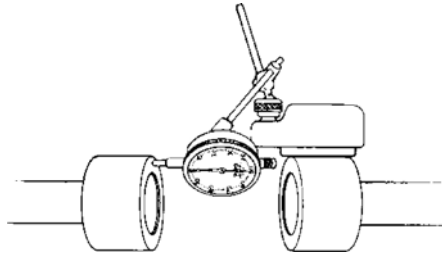
The normal gap (distance between hub and insert) is approximately 1/16". However, the coupling manufacturer's instructions should be followed. Check alignment by using calipers at 90° intervals on the circumference on the outer end of hubs. When caliper measurements are identical, the unit is in angular alignment. See Fig. 12.



**Figure 12:**

3. Flexible Spacer Couplings

Place a dial indicator on one shaft hub and rotate that hub 360°. Take readings from the face of the other hub. Alignment is achieved when indicator does not deflect more than .002". See Fig. 13.



**Figure 13: Dial indicator**

## 2.7 Piping - general

1. All piping must be supported independently of the pump. The piping should always "line-up" naturally with the pump flanges. Never draw the piping into place by use of force at the flanged suction and discharge connections of the pump, as this may impose dangerous strains on the unit and cause misalignment between pump and driver.
2. The piping, both suction and discharge, should be as short and direct as possible. Avoid all unnecessary elbows, bends, and fittings, as they increase the friction losses in the piping. The size of pipe and fittings should be carefully selected and of sufficient size to keep the friction losses as low as practical.
3. Piping must not be connected to the pump until the grout has thoroughly hardened and the foundation bolts, as well as driver and pump hold down bolts have been tightened.
4. When handling liquids at elevated temperatures, it is suggested that expansion loops or joints be properly installed in suction and/or discharge lines so that linear expansion of the piping will not draw the pump out of alignment.

If such expansion loops or joints are not used, the forces and moments, due to thermal expansion of the piping system, that can act upon the pump inlet and discharge flanges must be determined and must not exceed the limits permissible for the specific pump in question.

Such installations require extremely careful and precise attention to hot alignment procedures. See [4.5 Alignment - final on page 32](#).

5. On units handling corrosives, the piping can be arranged so that corrosives can be flushed from pump prior to opening unit for service. See Fig. 14. During operation, valves "1" and "3" would be dosed, "2" and "4" open. Prior to dismantling, close valves "2" and "4", open "1" and "3". Introducing water at valve "3" will allow water to flush pump and drain at valve "1".

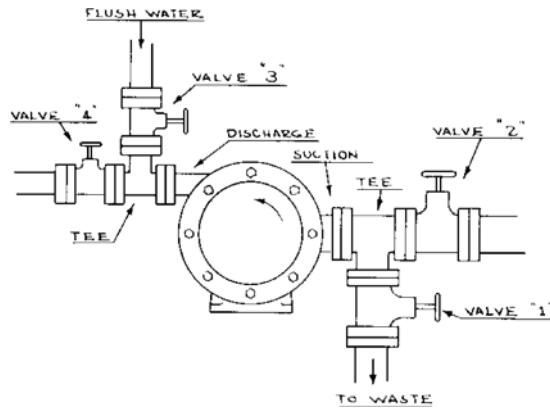


Figure 14:

## 2.8 Piping - suction

### General

Properly installed suction piping is of extreme importance for trouble-free centrifugal pump operation.

1. Use of elbows close to the pump suction flange should be avoided. Where used, elbows should be long radius.

On double suction pumps, if an elbow must be used at the pump suction flange, it must be in a vertical position only. If an elbow must be used in other than a vertical position, it is permissible only providing there is a minimum of two diameters of straight pipe between the elbow and pump suction flange.

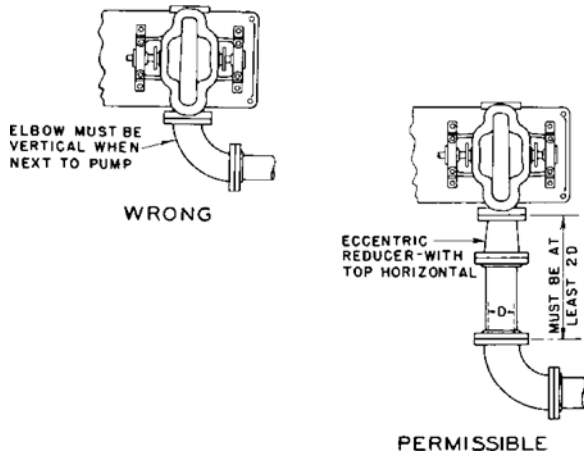
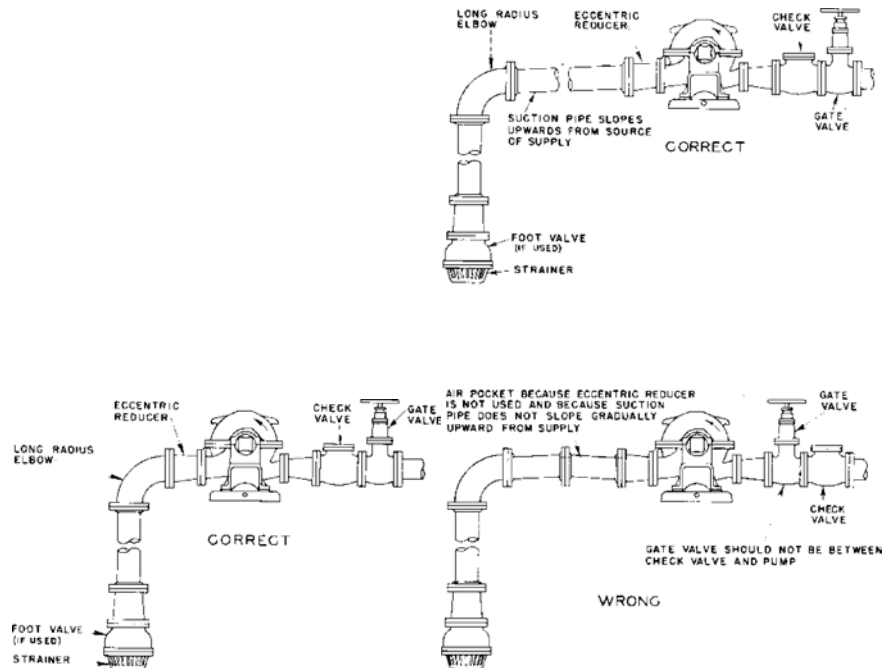


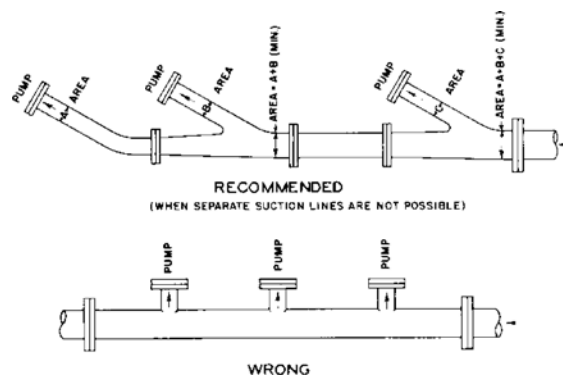
Figure 15:

2. The suction pipe should never be of smaller diameter than the pump suction. Use of suction pipe one or two sizes larger than the pump suction, with a reducer at the pump suction flange, is desirable.
3. Reducers, if used, should be eccentric and preferably at the pump suction flange, sloping side down.



**Figure 16:**

4. A centrifugal pump should never be throttled on the suction side.
5. Suction strainers, when used, should have a net "free area" of at least three times the suction pipe area.
6. Separate suction lines should be used when more than one pump is operating from the same source of supply. If it is not possible to have separate lines, piping arrangement shown in Fig. 17 is recommended.

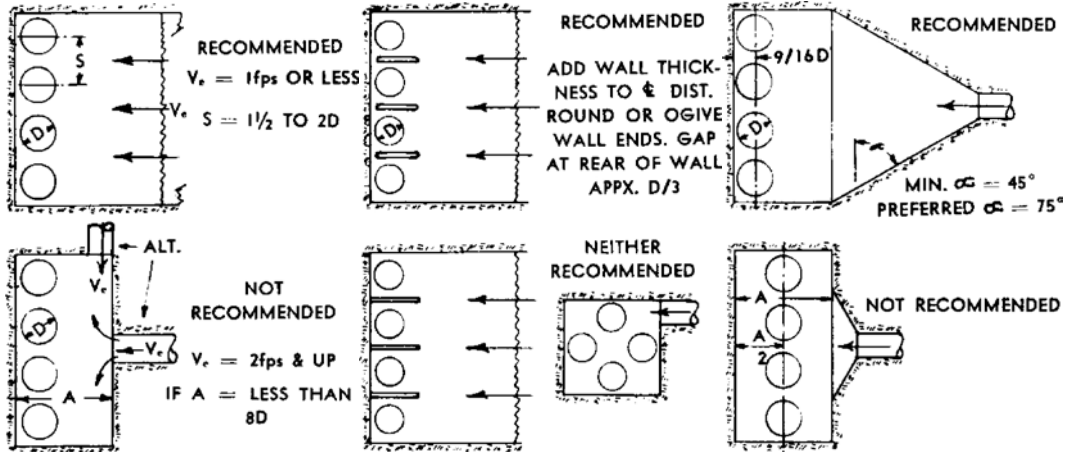


**Figure 17:**

### Suction piping design for large pumps

Large units taking their suction supply from sumps require special attention. A properly designed sump is a must. The larger the unit, the more important these considerations become. A 3000 GPM pump should be considered a large unit.

The following sketches will show the preferred pipe arrangement within the sump. Pipe should be located near the back wall of the sump as shown in Fig. 18 and should not be subjected to rapid changes in direction of the flow pattern.



**Figure 18:**

The velocity of the water approaching the pump suction pipe should be kept to a maximum of one foot per second to avoid air being drawn into the pump. Pump suction inlet velocities and submergence (the height of the water above the pump inlet) are two additional factors that must be considered. These factors vary so greatly with the size and capacities of the individual pumps and systems that past experience, or a good reference, should be relied upon in arriving at these values.

The suction pipe should be sized to obtain a flow velocity of 4 to 7 feet per second. Changes in flow direction should be avoided wherever possible, especially near the pump suction. A reducer at the pump suction flange to smoothly accelerate and stabilize flow into the pump is desirable.

Refer to the nearest Goulds representative for further information.

**Installations with pump above source of supply - suction lift**

1. Keep suction pipe free from air pockets - See Fig. 16.
2. Piping should slope upwards from source of supply.
3. No portion of piping should extend above the pump suction nozzle.
4. All joints must be air tight.

**Installations with pump below source of supply - suction head or flooded suction**

1. A gate valve should be installed in the suction line to permit closing of the line for pump inspection and maintenance.
2. Keep suction pipe free from air pockets.
3. Piping should be level or slope gradually downward from the source of supply.
4. No portion of the piping should extend below pump suction flange.
5. The size of entrance from supply should be no smaller than the suction pipe.
6. The suction pipe should be adequately submerged below the liquid surface at the source of supply.

**2.9 Piping - discharge**

1. Gate and check valves should be installed in the discharge line. The check valve should be located between the gate valve and pump to permit inspection of the check valve. The gate valve is required for priming, regulation of flow and for inspection and maintenance of the pump. The check valve is required to prevent reverse flow through the pump when the driver is turned off.

2. Increasesers, if used in discharge line, should be placed between the pump and check valves.
3. If quick-closing valves are installed in the system, cushioning devices should be used to protect the pump from surges and water hammer.

## 2.10 Connection of piping

Connect suction and discharge piping to the pump. Rotate pump shaft several times by hand to be sure there is no binding and that all parts are free. Recheck alignment.

---

### **NOTICE:**

On non-metallic pumps, use gaskets which are suitable for the flanges. PTFE envelope style is recommended.

---

## 2.11 Rotation

Serious damage may result if pump is run in wrong direction. Before coupling is connected, the motor should be wired and the direction of rotation checked. The direction of rotation is marked on the pump. Make sure driver rotates in the same direction.

## 2.12 Connection of coupling

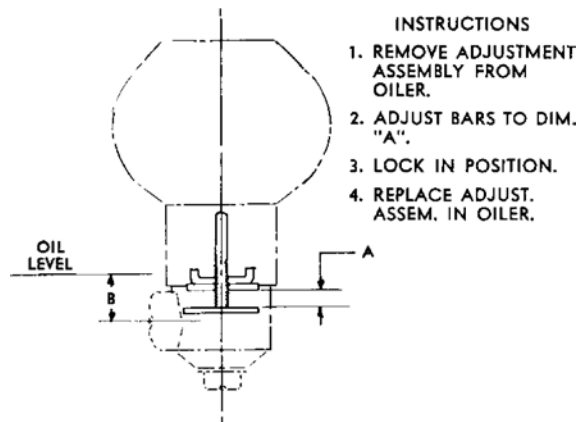
Connect coupling. Follow the manufacturers instructions. Spider-Insert type couplings are pre-assembled. If a coupling guard is furnished with the unit, make sure it is securely fastened.

# 3 Preparation for operation

## 3.1 Pump bearings

### Oil lubrication

1. Oil lubricated pumps are not lubricated at the factory. A high quality turbine type oil, with rust and oxidation inhibitors, should be used. Constant level oilers are supplied with most oil lubricated pumps. They are included in the box of fittings which accompanies the pump. The oiler needs to be set to maintain proper oil level. The adjustment should be made per the instructions below. See Figure 19. Correct dimensions for A and B are giving in [6.1 Lubrication on page 36](#). Check the assembly dimension print for proper location.



**Figure 19:**

Under normal operating conditions, an oil of 300

SSU viscosity at 100°F. ( approximately SAE-20) should be used. For extreme conditions refer to the factory or a lubrication expert for a recommendation.

Fill the bottle with the proper grade of oil and replace in the oiler housing. Oil reservoir in bearing housing is filled when an oil level remains in the bottle. Several fillings of bottle will be required. Never fill through the oil vent or through the oiler without use of the bottle.

### Grease lubrication

Grease lubricated pumps can be identified by the grease fittings located on the bearing housing. Sufficient lubricant is inserted at the factory for 2,000 hours of operation. Do not grease at too frequent intervals.

It is suggested that additional or replacement lubricant be added after 2,000 hours or at three-month intervals.

The lubricant should be renewed in the housings at least once annually. This should be done when the annual overhaul is made.

The grease should be of sodium lithium base, NGLI #2 consistency. Do not use graphite. Further greasing instructions are included in [6.1 Lubrication on page 36](#).

### Vertical pump bearings

The bearing above the pump support plate is a ball bearing and is grease lubricated. Follow the previous instructions for grease lubrication.



The pump steady bearings (below the pump support plate) are sleeve type and made of various materials depending upon the application of the pump. Refer to [6.1 Lubrication on page 36](#) for specific details.

### Close-coupled pumps

Close-coupled pumps contain no pump bearings. The only bearings in the unit are contained within the motor. Make sure that the motor bearings are properly

lubricated. Refer to the motor manufacturer for instructions.

## 3.2 Driver bearings and coupling

Check to be sure that driver bearings are properly lubricated. Contact the motor manufacturer for lubrication instructions. Refer to coupling instructions supplied separately for coupling lubrication.

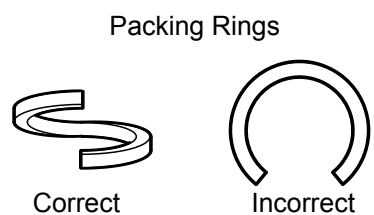
## 3.3 Stuffing boxes

### Packing

Before packing the stuffing box, make sure box is clean and contains no foreign material. If unit has a metal lantern ring, assembled with the pump, make sure ring is outside the stuffing box.

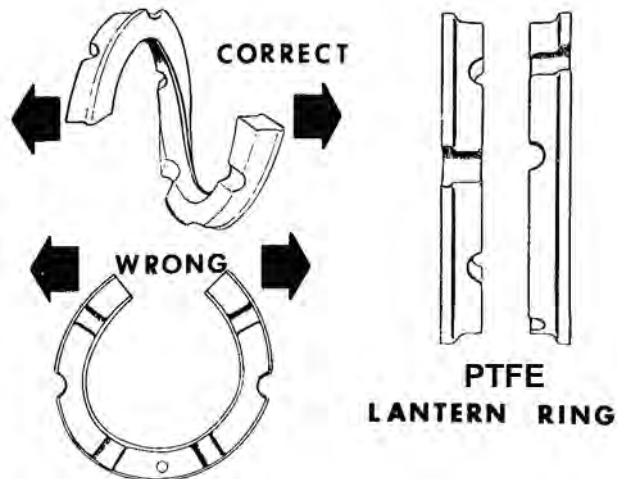
Stuffing box packing is furnished in the box of fittings which accompanies the pump. When packing the stuffing box, refer to [6.4 Sectional View and Parts List on page 41](#) for the arrangement of packing rings and lantern ring. Depending upon the particular pump and/or application, the lantern ring may be in the middle or bottom of the stuffing box, incorporated in another part or not used at all.

Some packing rings are die-formed and special care must be taken during installation. To install, twist the ring sideways just enough to get it around the shaft or sleeve. Do not attempt to pull rings straight out. See Fig. 20. Another form of packing ring is the bulk-type packing which is cut to the proper length. Each piece should be placed around the shaft or sleeve and the ends of the packing should just meet to form a smooth, perfect ring. If necessary, the ends should be trimmed to obtain this fit.



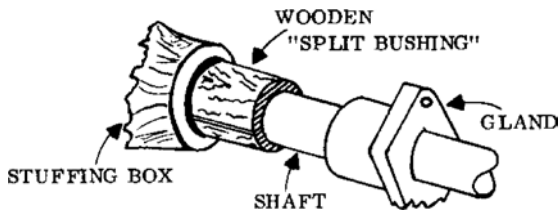
**Figure 20:**

There are two basic types of lantern rings - PTFE and metal. Two-piece PTFE lantern rings are supplied in most units. Install as shown in Fig. 21. Note: 2 pieces make one ring. Notches must face one another but need not be aligned.



**Figure 21:**

To pack the stuffing box, install the packing and lantern ring in the proper sequence. Each ring should be installed separately. Firmly seat each ring. Use of a wooden split bushing is recommended. See Fig. 22. Use gland to jack the bushing and ring into the box. Stagger joints in each ring 90°. Make sure center of lantern ring lines up with flush tap in the stuffing box. Any extra rings are spares.



**Figure 22:**

Tighten the gland nuts evenly but not tight. Follow adjustment procedure outlined in [4.4 Initial inspection after starting on page 31](#).

### Removal of packing

To remove packing from the stuffing box, the following steps should be followed:

1. Remove gland assembly.
2. Remove packing with a packing hook.
3. Remove lantern ring by inserting a wire hook into the ring on the outer edge.
4. Clean the stuffing box.
5. On horizontally split case pumps, an alternate method of removing packing is to remove the upper half casing. Refer to [6.3 Disassembly of pump on page 37](#). Remove packing and lantern ring and inspect sleeves. If deeply grooved, sleeves should be replaced.

### Mechanical seals

When mechanical seals are furnished, the description and identification is indicated on the order write-ups which are a part of the order acknowledgement, dimension print, and the packing list. Separate seal manufacturers' installation drawings are attached to the pump. The seals are installed and adjusted at the factory. The manufacturer's drawings should be filed for future use in maintaining the seal and in adjusting the seal when the pump is disassembled. To properly prepare the seal for operation, various cooling and flushing flows may have to be connected. In some cases, these flows are recirculated from the pump casing; in others, liquid from an outside source may be used. Connect cooling and flushing flows to seal as directed in subsequent steps.

**CAUTION:**

Connection of sealing liquid or grease lubricator (packed box)

If the stuffing box pressure is above atmospheric pressure, and the pumpage is clean, normal gland leakage of 40 to 60 drops per minute is usually sufficient to lubricate and cool the packing and sealing liquid is not required.

Sealing liquid or grease lubricator is required when:

1. Abrasive particles in the pumpage could score the shaft or sleeve.
2. Stuffing box pressure may be below atmospheric pressure due to pump running with suction lift, or when suction source is under vacuum. Under these conditions, the packing will not be cooled and lubricated and air will be drawn into the pump.

**Sealing liquid**

Sealing liquid may be supplied by recirculation of pumpage through a line from the casing to the stuffing box. If the pumpage is abrasive, an outside source of clean compatible liquid must be used at a pressure of 30 to 50 PSI above suction pressure.

## 3.4 Connection of sealing liquid or grease lubricator (packed box)

If the stuffing box pressure is above atmospheric pressure, and the pumpage is clean, normal gland leakage of 40 to 60 drops per minute is usually sufficient to lubricate and cool the packing and sealing liquid is not required.

Sealing liquid or grease lubricator is required when:

1. Abrasive particles in the pumpage could score the shaft or sleeve.
2. Stuffing box pressure may be below atmospheric pressure due to pump running with suction lift, or when suction source is under vacuum. Under these conditions, the packing will not be cooled

**Sealing liquid**

Sealing liquid may be supplied by recirculation of pumpage through a line from the casing to the stuffing box. If pumpage is abrasive, an outside source of clean compatible liquid must be used at a pressure of 30 to 50 PSI above suction pressure.

**Grease lubricator**

The grease lubricator is supplied when the use of a recirculating pumpage or outside sealing liquid is not desired. The grease should be insoluble in the pumpage.

## 3.5 Connection of cooling water piping

**Quench gland**

Most pumps which contain stuffing box packing have quench glands. Quenching prevents heat transfer along the pump shaft to the bearings. Quenching is also most important for smothering vapors and fumes given off at the stuffing box. This is particularly true on applications such as hot water.

The quenching liquid (usually water) must be from an outside source. It should be piped, with flexible pipe, into the tapped opening on top of the stuffing box gland. A shut-off valve should be installed.

### **Bearings**

Bearing cooling is available on some units. When it is available, cooling water must be connected to the jacket when pumping hot liquids. See the temperature limits listed under *Construction Details* in [6.4 Sectional View and Parts List on page 41](#). Valves should be installed in the coolant supply lines to regulate the flow.

### **Stuffing boxes**

Some units are equipped with cooling jackets around the stuffing box as standard. It is optional on various other models. Coolant lines are connected in the same manner as the bearing cooling lines.

### **Casing pedestals**

On some models, water cooled pedestals are available. Connection of coolant lines is made in the same manner as above.

### **Mechanical seals**

Seal materials (carbon, ceramic, PTFE, etc.) are suitable for use at temperatures to 500°F. (212° to 250°F if seal has rubber parts). However, for satisfactory operation, there must be a liquid film between the seal faces to lubricate them. If the liquid flashes to vapor, the faces will run dry and be damaged. To prevent this, the liquid must be cool. In general, this requires that the liquid be cooled so that the vapor pressure is well below the stuffing box pressure. Doubtful cases should be referred to Goulds for a recommendation. Refer to seal manufacturer's drawing for location of taps. Some methods which may be used to cool the seal are:

1. Dead Ended Seal Chamber

No liquid is circulated through the stuffing box.

The isolated or dead ended liquid around the seal is cooled by circulating water in the stuffing box jacket, if any.

2. Cool Liquid Flushing - External Source

A clean, cool compatible liquid is injected from an outside source directly into the seal chamber. The flushing liquid must be at a pressure 20 to 40 PSI greater than the pressure in the stuffing box. One-half to two GPM should be injected. A control valve and rotometer placed in the inlet line permits accurate regulation. Cooling water can be circulated through the stuffing box water jacket (if any) in addition to the external flush.

3. Cool Liquid Flushing - Product Cooling

In this arrangement, pumped liquid is piped from the pump casing, cooled in an external heat exchanger, then injected into the seal chamber. A control valve together with a rotometer and/or a dial thermometer should be installed in a line from the exchanger to the seal chamber. One-half to two GPM should be circulated. Cooling water, one to three GPM, should be circulated through the stuffing box jacket, if any.

## **3.6 Connection of drain piping**

All units contain tapped openings around the stuffing box for draining leakage. On corrosion resistant units, a drain pan is supplied with a tapped opening. Check the assembly dimension print for size and location.

## 3.7 Connection of equalizing piping

Some multi-stage pumps have equalizing piping to equalize pressure on the stuffing boxes (see [6.4 Sectional View and Parts List on page 41](#)). This piping is in the box of fittings which accompanies the pump. The ends of the piping must be connected to the openings in each stuffing box.

## 3.8 Impeller adjustment

Some end suction pumps, in addition to vertical pumps, have means of adjusting impeller clearance within the casing. The clearance was set at the factory, but in transit, the clearance may have been lost. Proper clearance must be attained before a pump is operated or serious damage may occur. Check and reset impeller clearance by method described in Impeller clearance adjustment.

# 4 Starting pump

## 4.1 Checking for free turning

Rotate shaft by hand to be sure rotating element is free. If element rubs or binds:

1. Check alignment
2. Pipe loads should be removed
3. Check impeller clearance (if external adjustment is possible) as outlined in Impeller clearance adjustment.
4. If unit is equipped with leveling bolts on frame or casing foot, check to be sure that bolts are not overtightened.

## 4.2 Regulation of cooling and flushing liquids

The supply of liquid to any cooling jackets, quench glands, or mechanical seals should be regulated by valves in the supply line. Approximate flow rates are as follows:

- Quench Glands - ½ to 1 GPM
- Cooling Jackets - 1 to 3 GPM
- Mechanical Seals - ½ to 2 GPM

The cooling lines should be checked periodically to see that they have not become clogged.

## 4.3 Priming

The pump must always be fully primed and the suction pipe full of liquid before pump is started.

If pump is run dry, the rotating parts within the pump may seize to the stationary parts since they depend upon the liquid being pumped for lubrication.

Several different methods of priming can be used, depending upon the type of installation and service involved.

Vertical sump pumps, when submerged, need not be primed since the pump is filled with liquid.

---

### NOTICE:

On glass-lined pumps, the thermal shock limit of the glass varies with the conditions of operation. do not introduce liquid to pump if temperature difference between liquid and pump is over 100°F. gradually heat pump before introducing hot liquids.

---

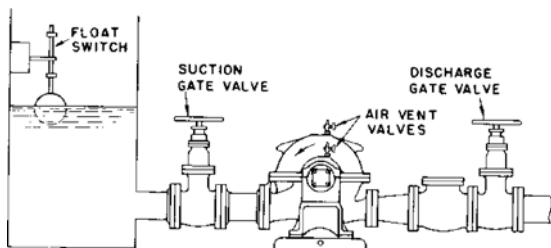


Figure 23:

When pump is installed as shown in Fig. 23, pump will prime itself. Open gate valve on suction and close discharge gate valve. Open air vent valves until all air is expelled and water flows through openings.

Close air vent valves, start pump and open discharge gate valve. Pump will continue to be primed for any future starting.

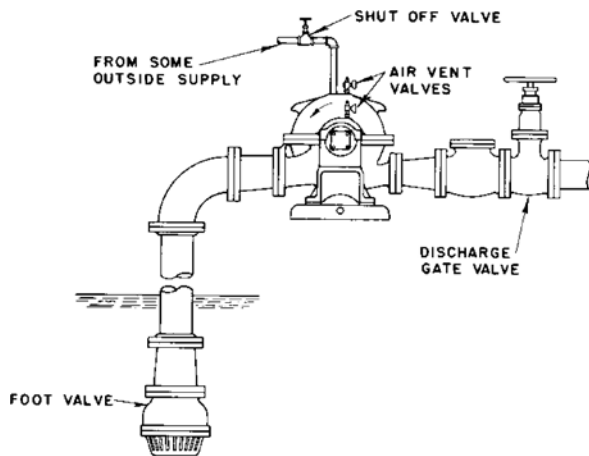
This method is the simplest and, particularly for automatic operation, the safest. A float switch in the suction reservoir can be arranged to stop pump, should there be failure of liquid supply.

### Priming with foot valve

With pump installed on suction lift, with foot valve at end of suction line, priming can be done any of the following three ways:

#### 1. Outside Supply

Close discharge gate valve, open air vent valves and open valve in priming supply line until all air is expelled and water issues from vent openings. Close air vent valves, close valve in priming supply line, and start pump; then open discharge gate valve.

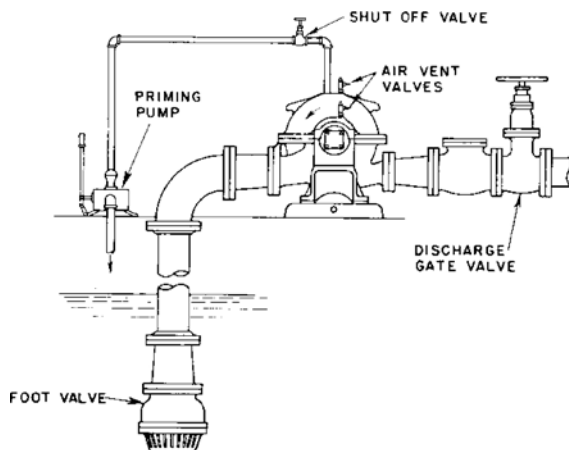


**Figure 24:**

#### 2. By Separate Hand, or Manually Controlled, Priming Pump

Close discharge gate valve (keep air vent valves closed) and open valve in line to priming pump. Exhaust air from pump and suction piping until water flows from priming pump. With priming pump running, close valve in priming line, start pump and open discharge gate valve.

An alternate method is to reverse connections on priming pump and extending priming pump suction to source of liquid supply. The pump may be primed by pumping liquid into casing until liquid comes out of the open air vent valves.



**Figure 25:**

In either of these methods (1) and (2) , the pump will remain primed, provided foot valve is tight. Any failure, however, of foot valve when pump is standing idle, will permit the pump to lose its prime. During long idle periods, the pump can also lose its prime through leakage from stuffing boxes.

The valve in bypass can be left open, in which event, during idle periods, loss through foot valve is constantly replenished from discharge line. This system is used for automatic operation where idle periods are of short duration and there is no danger of exhausting all liquid from discharge line, due to a leaky foot valve. The foot valve must be capable of withstanding static head pressure of the system.

3. Bypassing Around Discharge Check Valve

This method can be used only when there is liquid under some pressure in the discharge line. The original prime must be effected from some outside source. After subsequent idle periods, open air vent valves and open valve in bypass line around discharge check and gate valves until liquid flows from air vent openings. Close air vent valves and bypass valve, start pump and open discharge gate valve.

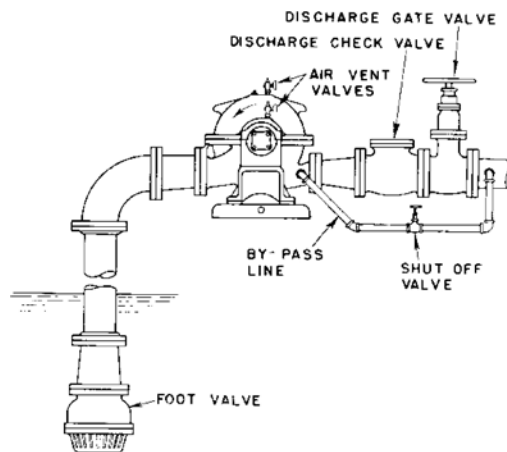


Figure 26:

**Priming by ejection**

On suction lift installation, an ejector, operated by steam, compressed air, or water under pressure, and connected to tapped opening in top of casing can be used to remove air from casing and suction line, thus priming the pump. See Fig. 27.

Close discharge gate valve, open valve "E" in steam, air or water pressure supply line. Open valve "S" in suction pipe of ejector connected to pump casing. Air will be evacuated and liquid will be drawn up into suction pipe and pump casing. When all air is evacuated, start pump, close valve "S" and valve "E", and open discharge gate valve.



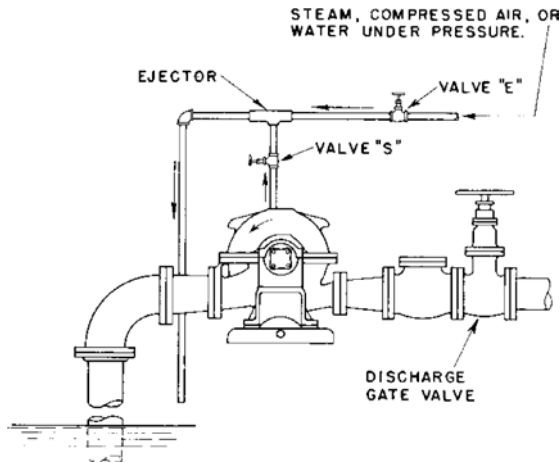


Figure 27:

### Priming by automatic primer pump

Where there is a fluctuating suction lift that occasionally might drop below the normal limits of the pump, or for installations where there is any quantity of air entrained in the pumpage, the system shown in Fig. 28 is very well adapted.

A vacuum tank and a vacuum gauge can be installed near the primer pump and the vacuum switch set to automatically start or stop the primer pump according to the vacuum required to keep the system primed.

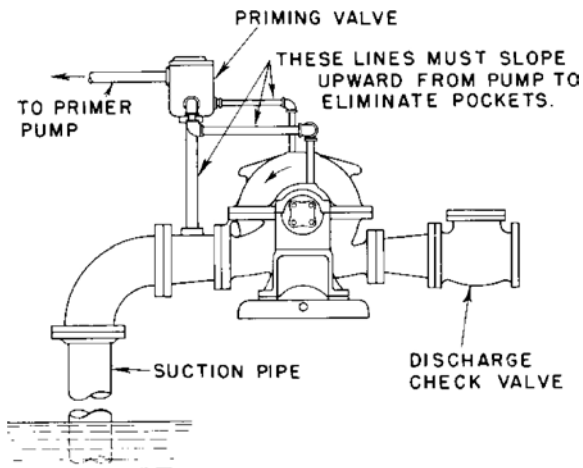


Figure 28:

## 4.4 Initial inspection after starting

### Packed box

With pump running at rated speed, the stuffing box gland can be adjusted. Draw gland nuts up evenly and only 1/6 of a turn at a time, allowing sufficient time between adjustments for the packing to adjust itself and the effect on the leakage to be observed. If any sign of heating is evident, shut down the pump and allow the box to cool. Several starts may be necessary before the box runs cool. Do not back off the gland nuts on a hot box as this will usually result in liquid leaking between the outer edge of the packing and the stuffing box bore. Remember that it takes newly installed packing some time to run in and that during this period, frequent attention and careful adjustments are necessary. Refer to [5.1 Stuffing box on page 34](#).

### **Mechanical seal**

The mechanical seal was adjusted at the factory. If the seal leaks slightly when pump is first started, a few

Some units do not require doweling since lock washers are furnished which hold the pump and driver feet securely in place.

On other units, the pump and driver feet should be doweled after installation is completed, and the unit is in correct final alignment. Taper dowel pins, included in the box of fittings, are furnished for these units.

---

#### **NOTICE:**

on all multi-stage units, dowel pins (if supplied) should be used on the coupling end of pump only. do not dowel feet on outboard end of pump.

---

On units to be doweled (except those noted above), drill through two diagonally opposite feet of the pump into the bedplate. Use a reamer with a  $\frac{1}{4}$ " per foot

taper. The dowels should extend well into the bedplate but project above the pump feet. Drivers should also be doweled but the driver manufacturer should be contacted for instructions.

## **4.5 Alignment - final**

Final adjustment can only be accomplished after the unit has been run under actual operating conditions for a sufficient length of time to bring the unit up to operating temperature.

After this warm-up period has elapsed, stop the unit and immediately disconnect the coupling and check the alignment. On

Back-Pull Out end suction units, the frame foot should be loosened to relieve any strain due to thermal

expansion. On units which have jacking bolts on the foot, loosen the hold-down bolts. On units which have a slotted hole on the foot near the bearing frame, loosen the foot-to-bearing frame bolt. Make sure motor switch is locked out to prevent accidental rotation. After a minute or two, re-tighten foot bolts.

Repeat each alignment procedure outlined in [2.6 Alignment procedures on page 13](#).

Reconnect coupling.

Check final alignment after approximately one week of operation.

## **4.6 Doweling**

Some units do not require doweling since lock washers are furnished which hold the pump and driver feet securely in place.

On other units, the pump and driver feet should be doweled after installation is completed, and the unit is correct final alignment. Taper dowel pins, included in the box of fittings, are furnished for these units.

---

#### **NOTICE:**

On all multi-stage units, dowel pins (if supplied) should be used on the coupling end of pump only. Do not dowel feet on outboard end of pump.

---

On units to be doweled (except those noted above), drill through two diagonally opposite feet of the pump into the bedplate. Use a reamer with a  $\frac{1}{4}$ " per foot taper. The dowels should extend well into the bedplate but project above the pump feet. Drivers should also be doweled but the driver manufacturer should be contacted for instructions.

# 5 Operation

## 5.1 Stuffing box

1. Stuffing boxes with packing rings - less quenching liquid or grease lubricator:

Periodically inspect stuffing box to see that there is sufficient leakage to lubricate the packing and maintain a cool box. Never draw up packing so that the stuffing box heats, as this will cause damage to both packing and sleeve. Draw up gland nuts slowly and evenly and only when pump is running.

After pump has been in operation for some time and the packing has been completely run in, at least 40 to 60 drops per minute of the liquid should be allowed to trickle from the stuffing box at all times for cooling and lubricating the packing and shaft sleeve.

2. Stuffing boxes with packing rings - with quenching liquid:

The same precautions as described above apply. However, the amount of leakage through the packing cannot be easily determined, due to the quenching liquid. In most cases, the valve on the quenching liquid supply line can be shut off for a short period and the amount of leakage determined as in step 1 above. In no instance should the gland be drawn up tight. Never throttle the clean liquid supply into the stuffing box as a substitute for proper adjustment of packing, a steady flow from the seal cage into the pump is required to prevent entrance of pumpage into the packing.

3. Stuffing boxes with packing rings - with grease lubricator:

Operation is the same as directed in step 1 above, with the addition that the handle on the lubricator should be given a turn or two about every 100 hours of operation.

4. Stuffing boxes with mechanical seal:

This type of box requires no attention other than to make sure that the circulating lines do not become clogged.

## 5.2 Operating at reduced capacities

Do not operate a centrifugal pump at greatly reduced capacities or with discharge gate valve closed, because the energy required to drive the pump is converted into heat. The temperature of the liquid in the pump may increase until the boiling point is reached. If this occurs, the rotating parts are exposed to vapor with no lubrication and they may score or even seize to the stationary parts.

---

### **NOTICE:**

If running clearances have enlarged due to wear, seizure may not take place and continued operation under these conditions may create an explosive

---

Hazard due to the confined vapor under high pressure and temperature.

To guard against possible damage, protective devices are available, such as:

1. Liquid temperature relay or thermostat which will shut off the unit if the liquid temperature in the pump exceeds a predetermined maximum. This device guards against possible damage due to running the pump against a closed valve.
2. Constant open by-pass orifice between the pump discharge and any check or regulating valve in the discharge line. The liquid through the orifice is returned to the suction source. The amount of liquid bypassed is a function of input horsepower and the allowable temperature rise. This device

also is insurance against damage due to running the pump against a closed discharge valve or very low flow conditions.

3. Bearing temperature relay which will shut the unit down if the bearing temperature exceeds a predetermined maximum.
4. Low suction pressure control which will shut off the unit should the suction pressure drop below a pre-established minimum. A centrifugal pump should never be throttled for capacity adjustment on the suction side.

## **5.3 Operating at reduced head**

On motor driven pumps, when discharge head or pressure is allowed to drop considerably below the rated point for any length of time, the motor should be watched for heating because the pump capacity increases with reduced head, as does horsepower consumption. If this condition is likely to persist, arrangements should be made either to manually or automatically throttle the discharge valve to build up head to a safe point.

## **5.4 Operating with surge conditions in line**

If a pump is installed with a quick closing valve in discharge line that closes when pump is running, dangerous pressure surges may be built up that can cause damage to the pump or line. In services of this kind, some cushioning arrangement must be provided to protect the pumping equipment.

## **5.5 Operating under freezing conditions**

When exposed to freezing conditions and pump is standing idle, liquid inside the pump should be drained by removing drain plugs in bottom of casing and opening air cocks at top. Liquid inside cooling jackets or glands should also be drained.

# 6 Maintenance

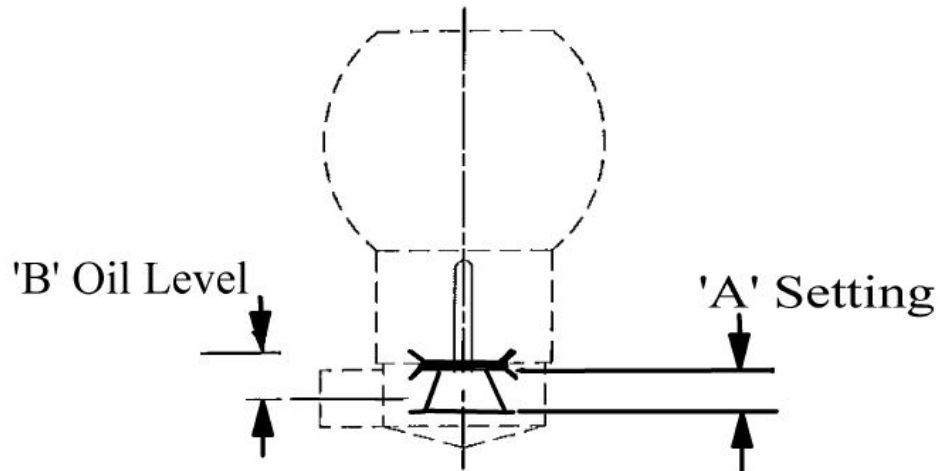
## 6.1 Lubrication

### Lubrication

1. Oil Lubrication – (Refer to [3.1 Pump bearings on page 22](#) for oil specifications). Oil lubricated ball bearings are optional on the Model 3107. The Bearings are not lubricated at the factory.
  1. Remove adjustment assembly from oiler.
  2. Adjust bars to Dim. A.
  3. Lock in position.
  4. Replace adjustment assembly in oiler.

Oil lubricated pumps are supplied with an oiler with maintains a constant oil level in the bearing frame. See Figure 30 for oiler location.

1. Before installing the oiler on the bearing frame, set the oiler adjustment:



Oiler Size	A	B
#1 (1-1/4 oz.)	9/32"	3/8"

**Figure 29:**

2. Install oiler.
  3. Fill oiler bottle with oil and replace in the oiler housing. Oil reservoir in frame is filled when oil remains visible in the bottle. Several fillings of the bottle will be required. Never fill through oil vent or the oiler housing without use of the bottle.
2. Grease lubrication – (Refer to [3.1 Pump bearings on page 22](#) for grease specifications). Grease lubricated ball bearings are standard on the Model 3107. These units can be identified by the grease fittings located on the bearing housing.

Grease lubricated bearings are lubricated at the factory. Do not grease at too frequent intervals.

To grease bearings insert grease through the Alemite fittings into bearing housing while rotating shaft until grease appears through grease relief fitting. Do not add additional lubricant after grease appears through relief fitting.

## 6.2 Impeller adjustment

Some end suction pumps, in addition to vertical pumps, have means of adjusting impeller clearance within the casing. The clearance was set at the factory, but in transit, the clearance may have been lost. Proper clearance must be attained before a pump is operated or serious damage may occur. Check and reset impeller clearance by method described in Impeller clearance adjustment.

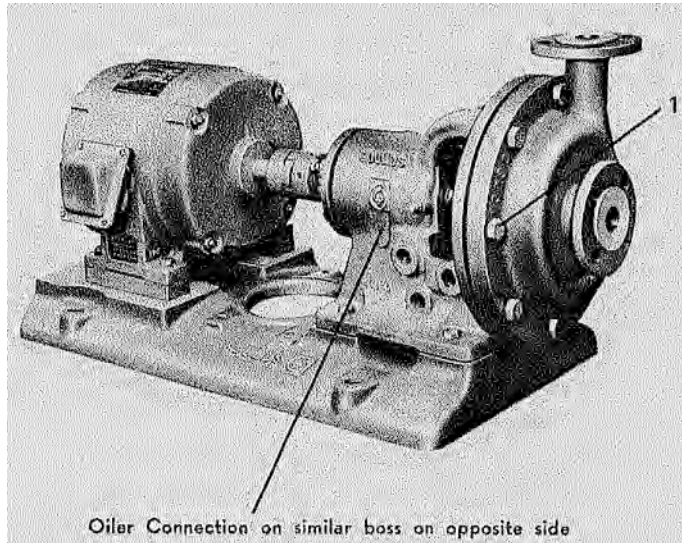
## 6.3 Disassembly of pump

To prepare pump for disassembly proceed as follows:

1. Lock out power supply to motor.
2. Shut off valves controlling flow to and from pump.
3. Remove all auxiliary tubing and piping.
4. Disconnect suction and discharge piping. If pumpage is hazardous or toxic care should be taken to flush liquid off pump parts.
5. Disconnect coupling.
6. Loosen bearing frame hold-down bolts and remove pump from bedplate.
7. Mark coupling position on shaft and remove pump half coupling hub.
8. If pump is oil lubricated remove constant level oiler and oil drain plug and drain oil. Pump can now be moved to the shop for disassembly.

The numbers located on the following figures refer to the procedure steps.

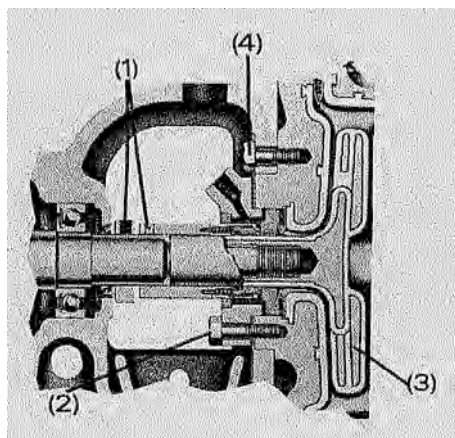
1. Loosen casing-to drain. Be careful if pumpage is corrosive or toxic. After draining remove bolts and casing and flush all traces of pumpage from the pump.



**Figure 30:**

2. All units contain a mechanical seal. Refer to the order acknowledgement and seal drawing (supplied with pump) to determine seal type. The following instructions are for three basic seal types available. single outside, PTFE bellows, and inside double seal determine the applicable type and carefully follow the procedures.

### **A. Single outside seal**



**Figure 31:**

(a-1) Loosen set screws in deflector and drive collar and move rotary portion of seal back on shaft.

(a-2) Remove gland bolts and slide gland toward bearing frame.

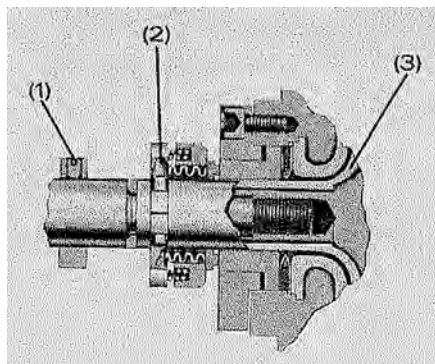
(a-3) Remove impeller. Threads are right hand. Hold impeller by hand and use a strap or spanner wrench to unscrew shaft.

(a-4) Remove bearing frame-to-stuffing box cover bolts and pull stuffing box cover from pump. Stationary seat and gaskets are located in cover. Do not damage seal face.

(a-5) Gland, seal rotary assembly, drive collar, and deflector cannot be removed until the shaft and bearing housing assembly is removed. Removal of these parts is described in Step 4.

(a-6) Refer to Step 3 for further instructions.

**B. PTFE bellows seal**



**Figure 32:**

(b-1) Loosen set screw in deflector.

(b-2) Loosen drive collar and carefully slide rotary assembly toward bearing frame.

(b-3) Remove impeller. Threads are right hand. Hold impeller by hand and use a strap or spanner wrench to unscrew shaft.

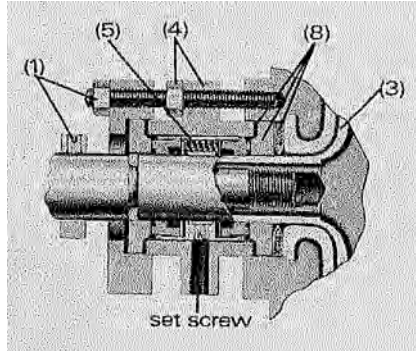
(b-4) Remove bearing frame-to-stuffing box cover bolts and pull stuffing box cover from pump. Stationary seat and gaskets are located in cover. Do not damage seal face.

(b-5) Slide rotary portion of seal and deflector off shaft.

(b-6) Refer to Step 3 for further instructions.

**C. Inside double seal**

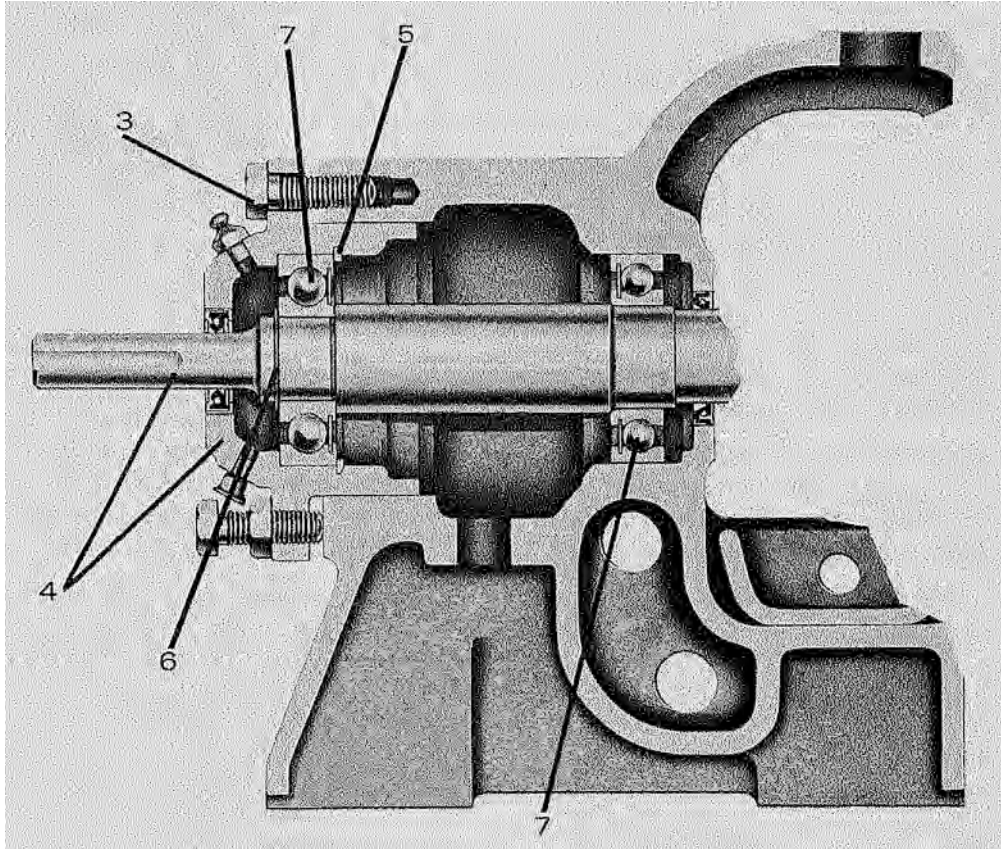




**Figure 33:**

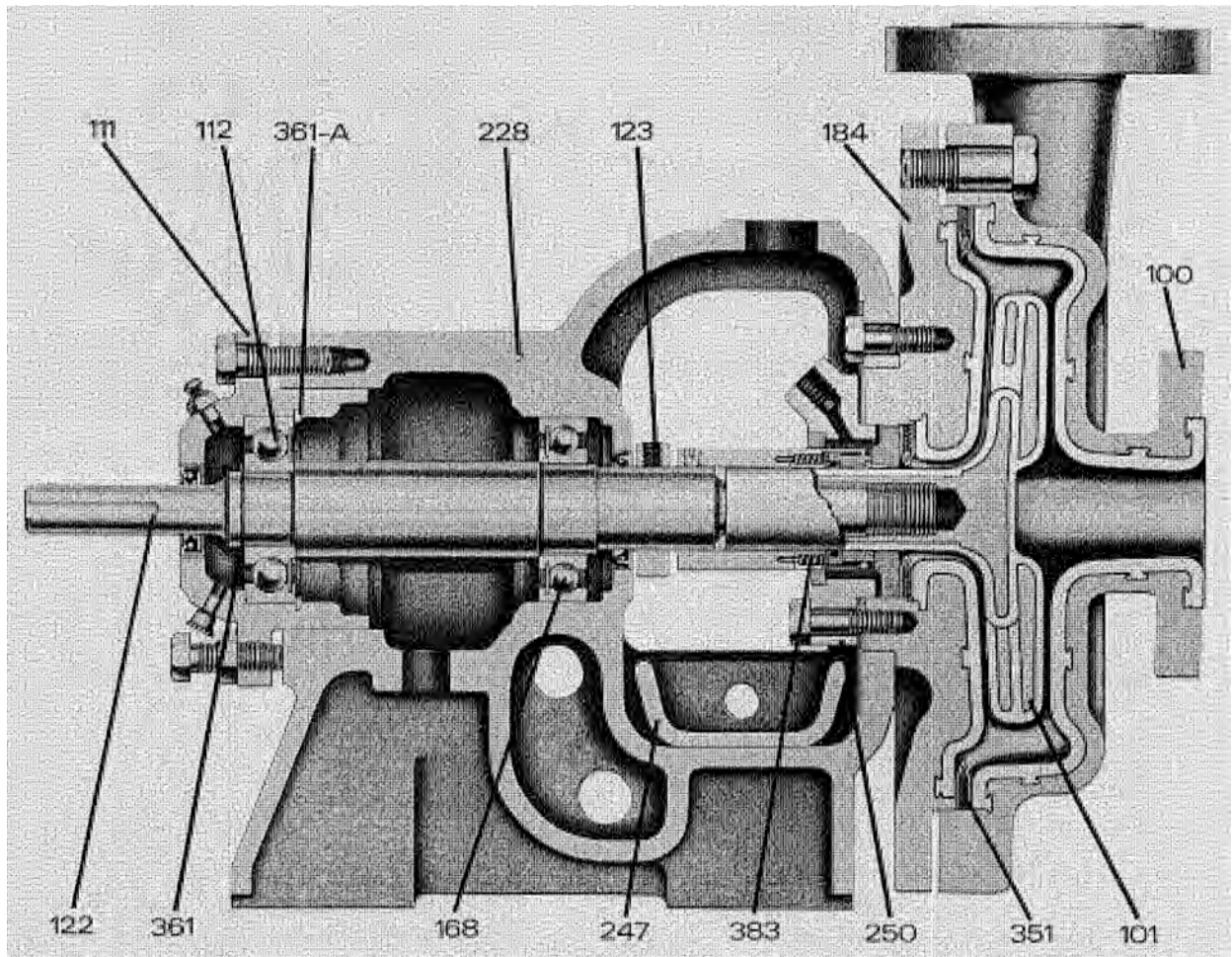
The rotary portion of the seal is fastened to the impeller hub by set screws. Loosen set screws by inserting a long Allen wrench into the tapped connection on the stuffing box. After loosening set screws, proceed as follows:

- (c-1) Loosen set screws in deflector and remove gland nuts. Slide gland and outboard stationary seat assembly toward bearing frame.
  - (c-2) Remove bearing frame-to-stuffing box cover bolts.
  - (c-3) Remove impeller. Threads are right hand. Hold impeller by hand and use a strap spanner wrench to unscrew shaft. The stuffing box cover, seal rotary, and impeller must be removed as a unit.
  - (c-4) Remove stuffing box nuts and stuffing box.
  - (c-5) Remove rotary portion of seal from impeller hub. Do not damage seal faces.
  - (c-6) Remove impeller from stuffing box cover.
  - (c-7) Remove gland and outboard stationary seat assembly and deflector from shaft.
  - (c-8) Remove inboard stationary seat and gaskets from stuffing box cover.
  - (c-9) Refer to Step 3 for further instructions.
3. Remove bearing housing bolts.
  4. Carefully slide shaft assembly out of bearing frame. On units with outside seals, make sure deflector does not bind on shaft or damage grease seal. The gland, rotary portion of seal drive collar and deflector can be removed after shaft has been partially removed. Do not damage lapped seal face.
  5. Remove bearing housing retaining ring. Use Waldes Truarc pliers (#5 or #25). Slide bearing housing off shaft. Make sure there are no burrs on shaft which could damage grease seal.
  6. Remove shaft retaining ring. Use Waldes Truarc pliers (#2, 4, 22 or 24).
  7. Remove ball bearings using a bearing puller as shown in [8.4 Bearing removal on page 51](#), Fig 33. Care must be taken to prevent damage to bearings. Never use a hammer to drive shaft through bearings. Protect bearings from contamination.



**Figure 34:**

## 6.4 Sectional View and Parts List



**Figure 35: Sectional view**

**Table 3: Parts list**

Item No.	No. reg. per pump	Part Name	Material
100	1	Casing	PTFE & ductile iron
101	1	Impeller	PTFE & ductile iron
111	1	Bearing Housing	Cast Iron
112	1	Ball Brg.-Cpl. End (Grease Lube)	Steel
122	1	Shaft	Steel
123	1	Deflector	AISI 316
168	1	Ball Bearing (Inboard)	Steel
184	1	Stuffing Box Cover	PTFE Lined - ductile iron
228	1	Frame	Cast Iron
247	1	Drip Basin	ACI-CF8M
250	1	Gland-Mechanical Seal	Gould-A-Loy 20
351	1	Gasket-Casing	PTFE Envelope

Item No.	No. reg. per pump	Part Name	Material
351A	1	Gasket-Discharge Flange (not illustrated)	PTFE Envelope
351B	1	Gasket-Suction Flange (not illustrated)	PTFE Envelope
361	1	Retaining Ring - Shaft	Steel
361A	1	Retaining Ring - Bearing Housing	Steel
383	1	Mechanical Seal	Non-metallic

**Table 4: Construction Details**

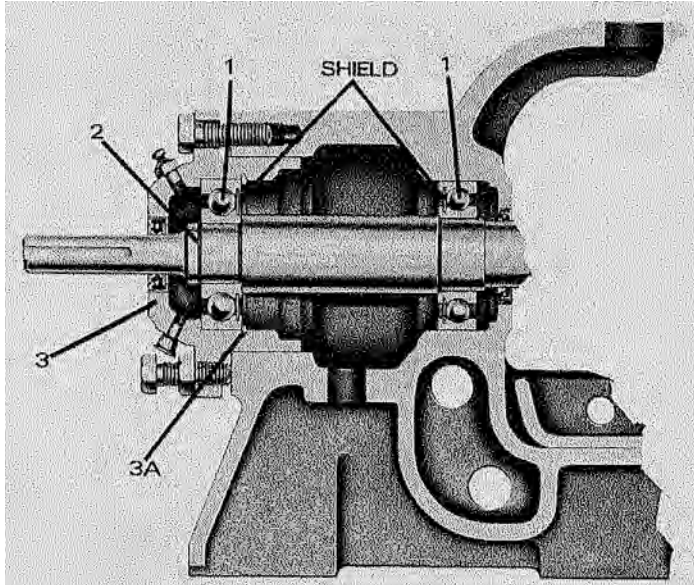
Pump Weight - Bare (lbs)		70
Shaft Diameter	in stuffing box	11/16"
	between bearings	1 1/4"
	at coupling	5/8"
Sleeve diameter		1 1/8"
Ball bearings	Coupling end	305 SF
	Inboard end	206 SF
Maximum total working pressure (-20 to 300°F)		150PSI
Maximum test pressure		225 PSI
Maximum liquid temperature - without cooling		180°F
Maximum liquid temperature - with cooling		300°F

## 6.5 Inspection and Overhaul

1. Shaft – Check for run-out to see that shaft has not been bent. Bearing seats and oil seal areas must be in perfect condition and free of scratches or grooves. Replace shaft if necessary.
2. Bearings – Replace if worn, loose or rough and noisy when rotated. If dirty, see [Section 8.3 Cleaning of bearings on page 50](#). New bearings should not be unwrapped until ready for use. Replacement bearings must be of the proper size and type as specified in [6.4 Sectional View and Parts List on page 41](#) (Construction Details).
3. Oil or grease seals – Replace if torn or otherwise damaged. The sizes used are: Inboard seal-Victor 62021 (W) or equal. Coupling end seal – Victor 62000 (W) or equal. If contamination of bearings or oil has been a problem on an oil lubricated pump, reverse the position of seals so lips face outward. In this position, a slight oil leakage may occur.
4. Retaining rings – Replace if bent or otherwise damaged. The sizes use are: Shaft retaining ring-5100 #98 Bearing housing retaining ring-5002 #244
5. PTFE coated parts – All PTFE coated parts should be thoroughly inspected for cracks or excessive wear prior to assembly.
6. Mechanical seal – Seal faces, gaskets and shaft sealing members must be in perfect condition. Replace worn or damaged parts.
7. General – All parts should be clean before assembly. This is especially important at retaining ring grooves, threads, gasket surfaces and bearing areas. Any burrs should be removed with crocus cloth.

## 6.6 Reassembly of pump

This procedure covers reassembly of pump after complete disassembly. Make sure all directions in [6.5 Inspection and Overhaul on page 42](#) have been followed.



**Figure 36:**

1. Lubricate bearings seats on shaft and slide bearings on shaft as far as possible by hand. Use a driving sleeve such as the one shown in [8.5 Ball bearing installation on page 51](#). Make sure sleeve contacts inner race only. Drive or press bearing on shaft until it is firmly seated against shoulder on shaft.

---

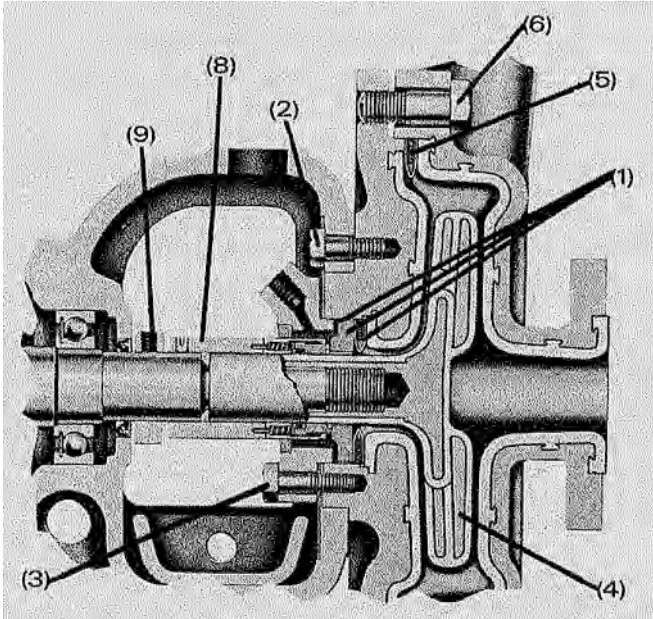
**NOTICE:**

Grease lubricated bearings are shielded on one side to retain grease. When correctly installed, shielded side of bearings will face one another. Do no mar shaft.

---

2. Place shaft retaining ring in groove on coupling end of shaft. Make sure ring is properly seated.
3. Slide bearing housing over coupling end bearing and place snap ring (3A) in groove. Ring is beveled on one side. Flat side must face bearing.
4. On oil lubricated units only, place O-ring in position on O.D. of bearing housing.
5. Slide shaft assembly into bearing frame. Be careful not to damage inboard oil or grease seal as shaft is pushed through. On units containing a single outside seal, place deflector, drive collar, rotary assembly and gland on shaft as it is pushed through bearing frame. See Fig. 37.
6. Push shaft through frame until bearing housing butts against the end of the bearing frame. Insert bearing housing-to-bearing frame bolts. Tighten finger tight, then back bolts off 1 turn.
7. All units contain a mechanical seal. Refer to the order acknowledgement and seal drawing (supplied with pump) to determine seal type. The following instructions are for the three basic seal types available: single outside, PTFE bellows, and inside double seal determine the applicable type and carefully follow the procedures.

**A. Single Outside Seal**



**Figure 37:**

(a-1) Place inner seal gasket, stationary seat, and outer seal gasket into stuffing box cover.

(a-2) Bolt stuffing box cover to frame.

(a-3) Bolt gland to stuffing box cover. Tighten bolts evenly.

(a-4) Screw impeller on shaft until impeller butts firmly against shaft shoulder. Care should be taken not to damage seal rotating assembly when installing impeller.

(a-5) Place casing gasket in casing.

(a-6) Bolt casing to stuffing box cover. Tighten bolts on alternate sides of casing so it does not cock. Tighten snugly but do not over-tighten. Gap should be even at all points between casing and cover. Bolt torque should be 18 to 20 ft. lbs.

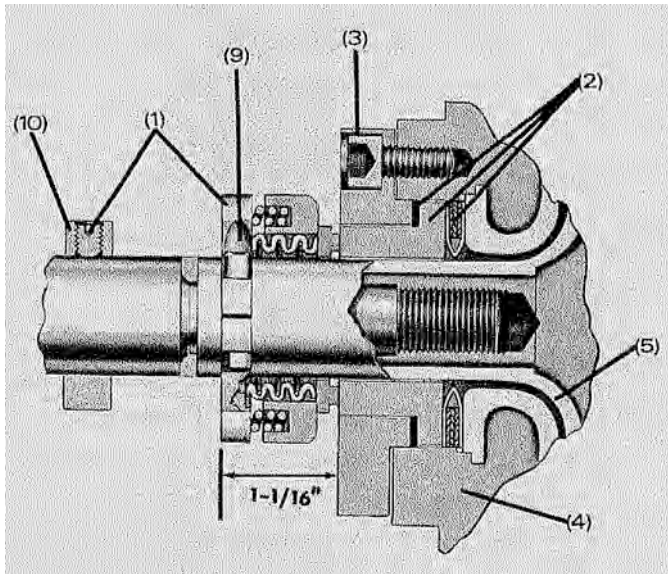
(a-7) Adjust impeller as outlined in Impeller clearance adjustment.

(a-8) Slide drive collar and rotating assembly until it contacts stationary seat. Compress the rotating assembly until the line of the thin metal disc which appears in the holes in the rotating assembly line up with the lines scribed on the rotating assembly. Tighten set screws.

(a-9) Tighten set screw in deflector.

(a-10) Refer to Sept 8 for further instructions.

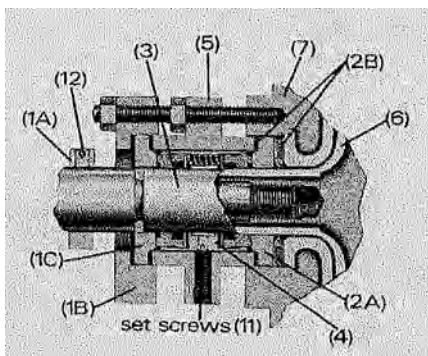
**B. PTFE Bellows Seal**



**Figure 38:**

- (b-1) Place deflector and rotary portion of seal on shaft.
- (b-2) Place inner seal gasket, stationary seat, and outer seal gasket in stuffing box cover.
- (b-3) Bolt gland to stuffing box cover. Be sure gaskets are in proper position and bolts are tightened evenly.
- (b-4) Bolt stuffing box cover to frame.
- (b-5) Screw impeller on shaft until impeller butts firmly against shaft shoulder. Care should be taken not to damage seal rotating assembly when installing impeller.
- (b-6) Place casing gasket in casing.
- (b-7) Bolt casing to stuffing box cover. Tighten bolts on alternate sides of casing so it does not cock. Tighten snugly but do not over-tighten. Gap should be even at all points between casing and cover. Bolt torque should be 18 to 20 ft. lbs.
- (b-8) Adjust impeller as outlined in Impeller clearance adjustment.
- (b-9) Slide clamping ring toward gland and compress to dimension shown in Figure 38. Tighten cap screw.
- (b-10) Tighten set screw in deflector.
- (b-11) Refer to Step 8 for further instructions.

### C. Inside double seal



**Figure 39:**

- (c-1) Slide deflector (1A), gland (1-B), outboard stationary seat gaskets (1-C) on shaft.
- (c-2) Place inboard stationary seat (2A) and gaskets (2B) in stuffing box cover.
- (c-3) Slide impeller hub through stuffing box cover.
- (c-4) Slide rotary portion of seal on impeller hub.
- (c-5) Slide stuffing box over rotary portion of seal and firmly tighten nuts.
- (c-6) Screw impeller on shaft until impeller butts firmly against shaft shoulder. Stuffing box cover must be held and carried into bearing frame while tightening impeller on shaft,
- (c-7) Bolt stuffing box cover to bearing frame.
- (c-8) Place casing gasket in casing and bolt casing to stuffing box cover. Tighten bolts on alternate sides of casing so it does not cock. Tighten snugly but do not over-tighten. Gap should be even at all points between casing and stuffing box cover. Bolt torque should be 18 to 20ft. lbs.
- (c-9) Slide gland assembly (gland, seat and gaskets) into position and tighten nuts evenly.
- (c-10) Adjust impeller as outlined in Impeller clearance adjustment.
- (c-11) After impeller adjustment, rotary portion of seal will be properly positioned. Using a long Allen wrench, tighten set screws in rotary.
- (c-12) Tighten set screw in deflector
- (c-13) Refer to Step 8 for further instructions.
  - 1. Replace pump half coupling hub.
  - 2. Replace pump on bedplate and tighten bearing frame hold-down bolts.
  - 3. Connect suction and discharge piping.
  - 4. Align pump as outlined in [2.6 Alignment procedures on page 13](#). Connect coupling.
  - 5. Lubricate bearings as outlined in Lubrication.
  - 6. Connect all auxiliary piping.
  - 7. Follow directions in [2 Installation on page 10](#) through [5 Operation on page 34](#) for starting and operating procedure.



---

# 7 Trouble check list

## 7.1 No liquid delivered

1. Pump not primed - casing and suction pipe not completely filled with liquid.
2. Speed too low\*.
3. Discharge head too high. Check system head (particularly friction loss).
4. Suction lift too high (suction pipe may be too small or long, causing excessive friction loss). Check with vacuum or compound gauge.
5. Impeller or suction pipe or opening completely plugged.
6. Wrong direction of rotation.
7. Air pocket in suction line.
8. Stuffing box packing worn - or liquid seal plugged - allowing leakage of air into pump casing.
9. Air leak in suction line.
10. Not enough suction head for hot or volatile liquids. Check carefully as this is a frequent cause of trouble on such service.

\* When directly connected to electric motors, check whether motor wiring is correct and receives full voltage. When directly connected to steam turbines, make sure that turbine receives full steam pressure.

## 7.2 Not enough liquid delivered

1. Pump not primed - casing and suction pipe not completely filled with liquid.
2. Speed too low.\*
3. Discharge head higher than anticipated. Check system head (particularly friction loss.)
4. Suction lift too high (suction pipe may be too small or long, causing excessive friction loss.) Check with vacuum or compound gauge.
5. Impeller or suction pipe or opening partially plugged.
6. Wrong direction of rotation.
7. Air pocket in suction line.
8. Stuffing box packing worn - or liquid seal plugged - allowing leakage of air into pump casing.
9. Air leak in suction line.
10. Not enough suction head for hot or volatile liquids. Check carefully as this is a frequent cause of trouble on such service.
11. Foot valve too small.
12. Foot valve or suction pipe not immersed deeply enough.
13. Mechanical defects:
  - Impeller clearance too great
  - Impeller damage

\* When directly connected to electric motors, check whether motor wiring is correct and receives full voltage. When directly connected to steam turbines, make sure that turbine receives full steam pressure.

## 7.3 Not enough pressure

1. Speed too low.\*

2. Air or gases in liquid.
3. Impeller diameter may be too small.
4. Mechanical defects:
  - Impeller clearance too great
  - Impeller damaged
5. Wrong direction of rotation.
6. Be sure pressure gauge is in correct place on discharge nozzle or discharge pipe.

\* When directly connected to electric motors, check whether motor wiring is correct and receives full voltage. When directly connected to steam turbines, make sure that turbine receives full steam pressure.

## 7.4 Pump works a while and then quits

1. Leaky suction line.
2. Stuffing box packing worn - or liquid seal plugged - allowing leakage of air into pump casing.
3. Air pocket in suction line.
4. Not enough suction head for hot or volatile liquids. Check carefully as this is a frequent cause of trouble on such service.
5. Air or gases in liquid.
6. Suction lift too high (suction pipe may be too small or long, causing excessive friction loss). Check with vacuum or compound gauge.
7. Impeller plugged.
8. Obstruction in suction or discharge line.
9. Casing gaskets damaged.

## 7.5 Pump takes too much power

1. Speed too high.
2. Head lower than rating, pumps too much liquid.
3. Liquid heavier than anticipated. Check viscosity and specific gravity.

\* When directly connected to electric motors, check whether motor wiring is correct and receives full voltage. When directly connected to steam turbines, make sure that turbine receives full steam pressure.

4. Mechanical defects:
  - Shaft bent
  - Rotating element binds
  - Stuffing box too tight
  - Impeller clearance too great
5. Wrong direction of rotation, or impeller installed backwards.

## 7.6 Pump leaks excessively at stuffing box

1. Packing is worn or not properly lubricated.
2. Packing is incorrectly inserted or not properly run in.
3. Packing is not correct for liquid handled.
4. Shaft sleeve scored.

## 7.7 Pump is noisy or vibrates

1. Hydraulic noise - cavitation, suction lift too high. Check with vacuum or compound gauge.
2. Mechanical defects:
  - Shaft bent
  - Rotating parts bind, are loose or broken
  - Bearings worn out
  - Coupling misaligned

## 7.8 High bearing temperature

Refer to [8.1 Bearing temperatures on page 50](#).

1. Pump and driver misalignment.
2. Pump capacity too low.
3. Improper lubrication.
4. Excessive vibration.
5. Bent shaft.
6. Rotating element binds.

# 8 Care and Maintenance of Bearings

## 8.1 Bearing temperatures

All bearings operate at some temperature above that of the surrounding atmosphere, unless cooled. Heat is generated within the bearing due to rolling friction, churning of oil and the "drag" of the race.

Do not use the human hand as a thermometer. A temperature which feels "hot" varies from 120°F - 130°F depending upon the individual. Above this temperature, the human hand is worthless in estimating temperature.

Bearing temperatures up to 180°F are normal. Determine the temperature accurately by placing a contact type thermometer against the bearing housing. It should be recorded in a convenient location for reference. The stability of the temperature, rather than the number of degrees, is the best indication of normal operation. A sudden increase in temperature is an indication of danger and a signal to investigate. The unit should be checked for abnormal hydraulic operation and unnecessary loads, such as coupling misalignment, etc.

## 8.2 Bearing inspection

### 1. Ball and Roller Bearings

Ball and roller bearings can be checked for visible wear by slowly turning the races and watching for pits or worn areas on the balls, rollers or raceways. The bearings can also be inspected by holding the inner race and spinning the outer race. If any rasping noises are emitted or the bearing "catches", it should be replaced. If any wear on the races is apparent, replacement is suggested.

### 2. Sleeve Bearings

Sleeve bearings should be inspected to determine if any deep scratches or gouges (other than oil grooves) are present. The babbitted surfaces should also be free of high or low spots. Unless these surfaces are completely smooth, they should be replaced if they cannot be "scraped in."

## 8.3 Cleaning of bearings

The life of a bearing can be drastically reduced if contaminated with even a small amount of dust or dirt. All bearing assembly operations should be done in as dust-free an atmosphere as possible. All tools, as well as the hands, should be kept clean.

If new bearings are to be installed, they should not be unwrapped until ready for installation and should not be cleaned or washed.

If old bearings are dirty, they should be replaced. Washing the bearings does not guarantee cleanliness and is risky at best. If new bearings are not readily available, and immediate reassembly is necessary, dirty bearings can be cleaned as follows:

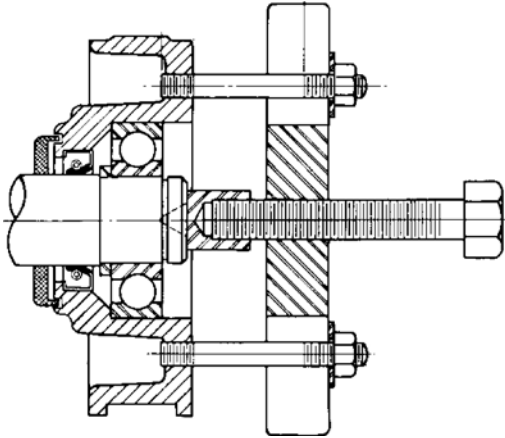
Pour one or two quarts of clean, water free kerosene into a clean pail. Dip the bearings into the kerosene and agitate slowly. Repeat until bearing is completely clean. Blow dry with clean filtered compressed air. With ball bearings, hold the two races together, but allow the inner race to rotate a few turns now and then to dislodge the kerosene from the retainer pockets. When the bearing has been blown dry, oil it immediately with a good grade of clean machine oil to prevent corrosion or rust.

If there is any question as to the condition of bearings, it is always best to replace them. This may prevent an unplanned shutdown.

## 8.4 Bearing removal

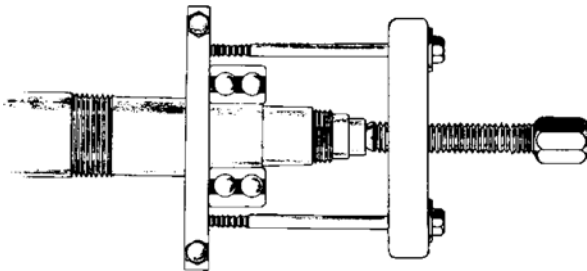
### 1. Ball Bearings

A puller such as the one shown in Fig. 40 should be used. The puller bar must be square with the end of the shaft at all times in order to keep even pressure on the outer circumference of the bearing. The puller screw should be tightened steadily to enable the bearing to slide smoothly off the shaft. Do not damage the end of the shaft.



**Figure 40:**

On some units, the bearing housings slide off the bearings and the puller such as the one shown in Fig. 41 should be used. This type of puller pulls directly against the bearing itself. The puller bar must be square with the end of the shaft at all times and the puller screw should be tightened steadily to enable the bearings to slide smoothly off the shaft. Do not damage the end of the shaft.



**Figure 41:**

### 2. Sleeve Bearings

After the bearing shells have been removed, a bearing puller, such as shown in Fig. 41 should be used to remove the ball bearing. The puller bar must be square with the end of the shaft at all times and the puller screw should be tightened steadily to enable the bearing to slide smoothly off the shaft. Do not damage the end of the shaft.

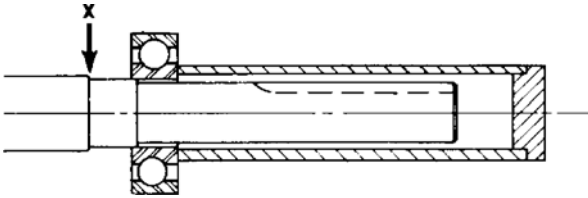
After the bearings have been removed, they should be wrapped in dean paper or cloth to prevent contamination. Other parts which surround the bearings, such as bearing housings, should be kept clean in the same manner.

## 8.5 Ball bearing installation

A film of clean machine oil should be applied to the bearing seat on the shaft. The bearing should be started on the shaft by tapping the inner race with a hammer or mallet. Do not use a lead mall. The

bearing must be kept square at all times. Once the bearing is located on the shaft, a driving sleeve, such as the one shown in Fig. 40 should be used. The sleeve should contact the inner race of the bearing only. The bearing should be pressed or driven until it contacts shoulder "x".

Duplex thrust bearings must be mounted in the proper position as described in [6.6 Reassembly of pump on page 42](#).



**Figure 42:**

# 9 Ordering of spare parts

## 9.1 Spare parts

To ensure against possible long and costly downtime periods, especially on critical services, it is advisable to have spare parts on hand.

The most desirable parts to have on hand are the following:

1. Horizontally Split Case Pumps
  1. Rotating element. This is a group of assembled parts, including bearings, bearing housings, shaft, impeller(s), wearing rings, stuffing box bushings, and all rotating parts except the coupling.
  2. Stuffing box packing (if any) - one set for each stuffing box.
  3. Stuffing box gland packing (if any) - one set for each gland.
  4. Mechanical Seals (if any) - one seal for each stuffing box.
2. Frame Mounted End Suction Pumps
  1. Support Head. This is a group of assembled parts which includes all parts except the casing, suction cover and coupling. The impeller is not mounted on the shaft.
  2. Stuffing box packing (if any) - one set.
  3. Stuffing box gland packing (if any) - one set.
  4. Mechanical seal (if any) - one.
3. Back Pullout End Suction Pumps
  1. Back Pull-Out assembly. This is a group of assembled parts which includes all parts except the casing and the coupling.
  2. Stuffing box packing (if any) - one set.
  3. Stuffing box gland packing (if any) - one set.
  4. Mechanical seal (if any) - one.

With these parts on hand, pump can be easily and quickly reconditioned by replacing the worn parts.

An alternate, though not as desirable as that stated above, is to have on hand parts that are most likely to wear and which can be used as needed.

Following is a list of these suggested parts:

1. Stuffing box packing (if any) - one set for each stuffing box.
2. Stuffing box gland packing (if any) - one set.
3. Mechanical seal (if any).
4. Shaft sleeve (if any).
5. Ball bearings - one of each.
6. Shaft nut (if any).
7. Bearing locknut and washer (if any).
8. Wearing rings (if any).
9. Shaft- one required.
10. Impeller key (if any).
11. Stuffing box bushings (if any).

If it is not convenient or desirable to carry the spare parts listed above, the following list is suggested as a minimum for servicing the pump under ordinary conditions of wear:

1. Stuffing box packing (if any) - one set for each stuffing box.
2. Stuffing box gland packing (if any) - one set.
3. Shaft sleeve (if any).
4. Ball bearings - one of each.
5. Shaft nut (if any).
6. Bearing locknut and washer ( if any).

## 9.2 Instructions for ordering spare parts

Repair orders will be handled with the minimum of delay if the following directions are followed:

1. Give Model No., size of the pump and serial number. These can all be obtained from the name-plate.
2. Write plainly the names, part numbers and materials of the parts required. These names and numbers should agree with those in [6.4 Sectional View and Parts List on page 41](#).
3. Give the number of parts required.
4. Give complete shipping instructions.



**Visit our website for the latest version of  
this document and more information:**  
[www.gouldspumps.com](http://www.gouldspumps.com)



ITT - Goulds Pumps Vertical Products Operation  
3951 Capitol Avenue  
City of Industry, CA 90601-1734  
USA

**Form IOM.3107.en-US.2021-09**