

 **GOULDS PUMPS**

Installation, Operation, and Maintenance Manual

Model NM 3196 i-FRAME



ITT

Table of Contents

1 Introduction and Safety	5
1.1 Introduction.....	5
1.1.1 Requesting other information	5
1.2 Safety	5
1.2.1 Safety terminology and symbols	6
1.2.2 Environmental safety.....	7
1.2.3 User safety	7
1.3 Product warranty	10
1.4 Ex Considerations and Intended Use.....	10
2 Transportation and Storage.....	16
2.1 Inspect the delivery	16
2.1.1 Inspect the package	16
2.1.2 Inspect the unit.....	16
2.2 Transportation guidelines	16
2.2.1 Pump handling	16
2.2.2 Lifting methods.....	16
2.3 Storage guidelines.....	19
2.3.1 Pump storage requirements	19
2.3.2 Frostproofing	20
3 Product Description	21
3.1 General description NM 3196.....	21
3.1.1 Part description NM 3196.....	22
3.2 General description i-ALERT® Equipment Health Monitor	23
3.3 Nameplate information	24
4 Installation.....	28
4.1 Pre-installation.....	28
4.1.1 Pump location guidelines	28
4.1.2 Foundation requirements	29
4.2 Baseplate-mounting procedures	30
4.2.1 Prepare the baseplate for mounting.....	30
4.2.2 Install the baseplate using shims or wedges.....	30
4.2.3 Install the baseplate using jackscrews	31
4.2.4 Install the baseplate using spring mounting	34
4.2.5 Install the baseplate using stilt mounting	35
4.2.6 Baseplate-leveling worksheet	37
4.3 Install the pump, driver, and coupling.....	38
4.4 Pump-to-driver alignment.....	38
4.4.1 Alignment checks	38
4.4.2 Permitted indicator values for alignment checks.....	39
4.4.3 Alignment measurement guidelines	39
4.4.4 Attach the dial indicators for alignment	40
4.4.5 Pump-to-driver alignment instructions.....	40
4.4.6 C-face adapter	43
4.5 Grout the baseplate.....	44
4.6 Piping checklists.....	45

4.6.1	General piping checklist	45
4.6.2	Suction-piping checklist.....	48
4.6.3	Discharge piping checklist.....	50
5	Commissioning, Startup, Operation, and Shutdown	52
5.1	Preparation for startup.....	52
5.2	Remove the coupling guard	53
5.3	Check the rotation	55
5.4	Impeller-clearance check	55
5.4.1	Impeller clearances (NM 3196).....	56
5.5	Impeller-clearance setting	56
5.5.1	Set the impeller clearance - dial indicator method (all except CV 3196, CV 3198, and LF 3196 size 1x1.5-4)	57
5.5.2	Set the impeller clearance - feeler gauge method (all except CV 3196, CV3198 and LF 3196 size 1x1.5-4).....	58
5.6	Couple the pump and driver	59
5.6.1	Install the coupling guard	60
5.6.2	Bearing lubrication	65
5.7	Shaft-sealing options.....	66
5.7.1	Mechanical seal options.....	67
5.7.2	Connection of sealing liquid for mechanical seals	67
5.8	Install the shaft guard - if provided	67
5.9	Pump priming	68
5.9.1	Prime the pump with the suction supply above the pump	68
5.9.2	Prime the pump with the suction supply below the pump	68
5.9.3	Other methods of priming the pump.....	69
5.10	Start the pump.....	69
5.11	i-ALERT® Equipment Health Monitor	70
5.12	Pump operation precautions	70
5.13	Shut down the pump	72
5.14	Deactivate the i-ALERT® Equipment Health Monitor.....	72
5.15	Reset the i-ALERT® Health Monitor	72
5.16	Make the final alignment of the pump and driver	72
6	Maintenance.....	74
6.1	Maintenance schedule	74
6.2	Bearing maintenance	75
6.2.1	Lubricating-oil requirements.....	76
6.2.2	Regrease the grease-lubricated bearings.....	76
6.2.3	Lubricate the bearings after a shutdown period	78
6.3	Shaft seal maintenance.....	78
6.3.1	Mechanical-seal maintenance.....	78
6.4	Disassembly.....	79
6.4.1	Disassembly precautions	79
6.4.2	Tools required.....	79
6.4.3	Drain the pump.....	80
6.4.4	Remove the coupling	80
6.4.5	Remove the back pull-out assembly	80
6.4.6	Remove the coupling hub	83
6.4.7	Impeller removal.....	84
6.4.8	Shaft guard removal (if provided).....	85

6.4.9 Seal-chamber cover removal	86
6.4.10 Remove the seal-chamber cover and backplate (NM 3196, 3198, CV 3198).....	86
6.4.11 Remove the frame adapter (MTi)	88
6.4.12 Remove the inboard labyrinth oil seal	88
6.4.13 Power-end disassembly	88
6.4.14 Disassemble the bearing frame	92
6.4.15 Guidelines for i-ALERT® Equipment Health Monitor disposal	93
6.4.16 Disassemble the C-face adapter	93
6.5 Pre-assembly inspections	93
6.5.1 Replacement guidelines.....	94
6.5.2 Shaft and sleeve replacement guidelines	96
6.5.3 Bearing-frame inspection	97
6.5.4 C-face adapter inspection	97
6.5.5 Seal chamber and stuffing box cover inspection.....	98
6.5.6 Bearings inspection.....	99
6.5.7 Bearing-housing inspection.....	99
6.5.8 Bearing fits and tolerances.....	100
6.6 Reassembly.....	101
6.6.1 Assemble the rotating element and the bearing frame (STi and MTi).....	101
6.6.2 Assemble the rotating element and the bearing frame (STi and MTi with duplex bearings)	104
6.6.3 Assemble the frame	107
6.6.4 INPRO labyrinth oil seal description.....	111
6.6.5 Assemble the INPRO labyrinth oil seal	111
6.6.6 Assemble the C-face adapter.....	112
6.6.7 Shaft sealing	112
6.6.8 Shaft guard installation (if provided).....	119
6.6.9 Install the impeller	120
6.6.10 Post-assembly checks	122
6.6.11 Install the back pull-out assembly (except HT 3196).....	122
6.6.12 Assembly references.....	125
6.6.13 Spare parts.....	126
6.7 Interchangeability drawings.....	127
6.7.1 NM 3196 interchangeability.....	127
6.8 Lubrication conversion	127
6.8.1 Frame lubrication conversion	127
6.8.2 Convert from greased-for-life or regreaseable to oil-lubricated bearings.....	128
6.8.3 Conversion from flood-oil to pure-oil mist.....	129
6.8.4 Convert from flood oil to regreaseable	130
7 Troubleshooting	131
7.1 Operation troubleshooting	131
7.2 Alignment troubleshooting.....	132
7.3 Assembly troubleshooting	132
8 Parts List and Cross-Sectionals	134
8.1 Parts list.....	134
9 Other Relevant Documentation or Manuals.....	140
9.1 For additional documentation	140
10 Local ITT Contacts	141

10.1 Regional offices 141

1 Introduction and Safety

1.1 Introduction

Purpose of this manual

The purpose of this manual is to provide necessary information for:

- Installation
- Operation
- Maintenance



CAUTION:

Failure to observe the instructions contained in this manual could result in personal injury and/or property damage, and may void the warranty. Read this manual carefully before installing and using the product.

NOTICE:

Save this manual for future reference and keep it readily available.

1.1.1 Requesting other information

Special versions can be supplied with supplementary instruction leaflets. See the sales contract for any modifications or special version characteristics. For instructions, situations, or events that are not considered in this manual or in the sales documents, please contact the nearest ITT representative.

Always specify the exact product type and serial number when requesting technical information or spare parts.

Specifications such as weights, dimensions or centers of gravity of the pump, pump unit or subassemblies are described in the supplier's applicable documentation.

1.2 Safety



WARNING:

- Risk of serious personal injury. Applying heat to impellers, propellers, or their retaining devices can cause trapped liquid to rapidly expand and result in a violent explosion. This manual clearly identifies accepted methods for disassembling units. These methods must be adhered to. Never apply heat to aid in their removal unless explicitly stated in this manual.
- The operator must be aware of the pumpage and take appropriate safety precautions to prevent physical injury.
- Risk of serious injury or death. If any pressure-containing device is over-pressurized, it can explode, rupture, or discharge its contents. It is critical to take all necessary measures to avoid over-pressurization.
- Risk of death, serious personal injury, and property damage. Installing, operating, or maintaining the unit using any method not prescribed in this manual is prohibited. Prohibited methods include any modification to the equipment or use of parts not provided by ITT. If there is any uncertainty regarding the appropriate use of the equipment, please contact an ITT representative before proceeding.

- If the pump or motor is damaged or leaking, electric shock, fire, explosion, liberation of toxic fumes, physical harm, or environmental damage may result. Do not operate the unit until the problem has been corrected or repaired.
- Risk of serious personal injury or property damage. Dry running may cause rotating parts within the pump to seize to non-moving parts. Do not run dry.
- Risk of death, serious personal injury, and property damage. Heat and pressure buildup can cause explosion, rupture, and discharge of pumpage. Never operate the pump with suction and/or discharge valves closed.
- Running a pump without safety devices exposes operators to risk of serious personal injury or death. Never operate a unit unless appropriate safety devices (guards, etc.) are properly installed. See specific information about safety devices in other sections of this manual.



CAUTION:

- Risk of injury and/or property damage. Operating a pump in an inappropriate application can cause over pressurization, overheating, and/or unstable operation. Do not change the service application without the approval of an authorized ITT representative.

1.2.1 Safety terminology and symbols

About safety messages

It is extremely important that you read, understand, and follow the safety messages and regulations carefully before handling the product. They are published to help prevent these hazards:

- Personal accidents and health problems
- Damage to the product
- Product malfunction

Hazard levels

Hazard level	Indication
<p>DANGER:</p>	A hazardous situation which, if not avoided, will result in death or serious injury
<p>WARNING:</p>	A hazardous situation which, if not avoided, could result in death or serious injury
<p>CAUTION:</p>	A hazardous situation which, if not avoided, could result in minor or moderate injury
<p>NOTICE:</p>	<ul style="list-style-type: none"> • A potential situation which, if not avoided, could result in undesirable conditions • A practice not related to personal injury

Hazard categories

Hazard categories can either fall under hazard levels or let specific symbols replace the ordinary hazard level symbols.

Electrical hazards are indicated by the following specific symbol:



ELECTRICAL HAZARD:

These are examples of other categories that can occur. They fall under the ordinary hazard levels and may use complementing symbols:

- Crush hazard
- Cutting hazard
- Arc flash hazard

1.2.1.1 The Ex symbol

The Ex symbol indicates safety regulations for Ex-approved products when used in atmospheres that are potentially explosive or flammable.



1.2.2 Environmental safety

The work area

Always keep the station clean to avoid and/or discover emissions.

Waste and emissions regulations

Observe these safety regulations regarding waste and emissions:

- Appropriately dispose of all waste.
- Handle and dispose of the processed liquid in compliance with applicable environmental regulations.
- Clean up all spills in accordance with safety and environmental procedures.
- Report all environmental emissions to the appropriate authorities.



WARNING:

If the product has been contaminated in any way, such as from toxic chemicals or nuclear radiation, do NOT send the product to ITT until it has been properly decontaminated and advise ITT of these conditions before returning.

Electrical installation

For electrical installation recycling requirements, consult your local electric utility.

1.2.2.1 Recycling guidelines

Always follow local laws and regulations regarding recycling.

1.2.3 User safety

General safety rules

These safety rules apply:

- Always keep the work area clean.
- Pay attention to the risks presented by gas and vapors in the work area.
- Avoid all electrical dangers. Pay attention to the risks of electric shock or arc flash hazards.
- Always bear in mind the risk of drowning, electrical accidents, and burn injuries.

Safety equipment

Use safety equipment according to the company regulations. Use this safety equipment within the work area:

- Hardhat
- Safety goggles, preferably with side shields
- Protective shoes
- Protective gloves
- Gas mask
- Hearing protection
- First-aid kit
- Safety devices

Electrical connections

Electrical connections must be made by certified electricians in compliance with all international, national, state, and local regulations. For more information about requirements, see sections dealing specifically with electrical connections.

Noise



WARNING:

Sound pressure levels may exceed 80 dbA in operating process plants. Clear visual warnings or other indicators should be available to those entering an area with unsafe noise levels. Personnel should wear appropriate hearing protection when working on or around any equipment, including pumps. Consider limiting personnel's exposure time to noise or, where possible, enclosing equipment to reduce noise. Local law may provide specific guidance regarding exposure of personnel to noise and when noise exposure reduction is required.

Temperature



WARNING:

Equipment and piping surfaces may exceed 130°F (54°C) in operating process plants. Clear visual warnings or other indicators should alert personnel to surfaces that may reach a potentially unsafe temperature. Do not touch hot surfaces. Allow pumps operating at a high temperature to cool sufficiently before performing maintenance. If touching a hot surface cannot be avoided, personnel should wear appropriate gloves, clothing, and other protective gear as necessary. Local law may provide specific guidance regarding exposure of personnel to unsafe temperatures.

1.2.3.1 Precautions before work

Observe these safety precautions before you work with the product or are in connection with the product:

- Provide a suitable barrier around the work area, for example, a guard rail.
- Make sure that all safety guards are in place and secure.
- Make sure that you have a clear path of retreat.

- Make sure that the product cannot roll or fall over and injure people or damage property.
- Make sure that the lifting equipment is in good condition.
- Use a lifting harness, a safety line, and a breathing device as required.
- Allow all system and pump components to cool before you handle them.
- Make sure that the product has been thoroughly cleaned.
- Disconnect and lock out power before you service the pump.
- Check the explosion risk before you weld or use electric hand tools.

1.2.3.2 Precautions during work

Observe these safety precautions when you work with the product or are in connection with the product:



CAUTION:

Failure to observe the instructions contained in this manual could result in personal injury and/or property damage, and may void the warranty. Read this manual carefully before installing and using the product.

- Never work alone.
- Always wear protective clothing and hand protection.
- Stay clear of suspended loads.
- Always lift the product by its lifting device.
- Beware of the risk of a sudden start if the product is used with an automatic level control.
- Beware of the starting jerk, which can be powerful.
- Rinse the components in water after you disassemble the pump.
- Do not exceed the maximum working pressure of the pump.
- Do not open any vent or drain valve or remove any plugs while the system is pressurized. Make sure that the pump is isolated from the system and that pressure is relieved before you disassemble the pump, remove plugs, or disconnect piping.
- Never operate a pump without a properly installed coupling guard.

1.2.3.3 Hazardous liquids

The product is designed for use in liquids that can be hazardous to your health. Observe these rules when you work with the product:

- Make sure that all personnel who work with biologically hazardous liquids are vaccinated against diseases to which they may be exposed.
- Observe strict personal cleanliness.
- A small amount of liquid will be present in certain areas like the seal chamber.

1.2.3.4 Wash the skin and eyes

1. Follow these procedures for chemicals or hazardous fluids that have come into contact with your eyes or your skin:

Condition	Action
Chemicals or hazardous fluids in eyes	<ol style="list-style-type: none"> 1. Hold your eyelids apart forcibly with your fingers. 2. Rinse the eyes with eyewash or running water for at least 15 minutes. 3. Seek medical attention.

Condition	Action
Chemicals or hazardous fluids on skin	<ol style="list-style-type: none"> 1. Remove contaminated clothing. 2. Wash the skin with soap and water for at least 1 minute. 3. Seek medical attention, if necessary.

1.3 Product warranty

Coverage

ITT undertakes to remedy faults in products from ITT under these conditions:

- The faults are due to defects in design, materials, or workmanship.
- The faults are reported to an ITT representative within the warranty period.
- The product is used only under the conditions described in this manual.
- The monitoring equipment incorporated in the product is correctly connected and in use.
- All service and repair work is done by ITT-authorized personnel.
- Genuine ITT parts are used.
- Only Ex-approved spare parts and accessories authorized by ITT are used in Ex-approved products.

Limitations

The warranty does not cover faults caused by these situations:

- Deficient maintenance
- Improper installation
- Modifications or changes to the product and installation made without consulting ITT
- Incorrectly executed repair work
- Normal wear and tear

ITT assumes no liability for these situations:

- Bodily injuries
- Material damages
- Economic losses

Warranty claim

ITT products are high-quality products with expected reliable operation and long life. However, should the need arise for a warranty claim, then contact your ITT representative.

1.4 Ex Considerations and Intended Use

Special care must be taken in potentially explosive environments to ensure that the equipment is properly maintained. This includes but is not limited to:



Follow these special handling instructions if you have an Ex-approved unit.

Personnel requirements

These are the personnel requirements for Ex-approved products in potentially explosive atmospheres:

- All work on the product must be carried out by certified electricians and ITT-authorized mechanics. Special rules apply to installations in explosive atmospheres.
- All users must know about the risks of electric current and the chemical and physical characteristics of the gas, the vapor, or both present in hazardous areas.
- Any maintenance for Ex-approved products must conform to international and national standards (for example, EN 60079-17).

ITT disclaims all responsibility for work done by untrained and unauthorized personnel.

Product and product handling requirements

These are the product and product handling requirements for Ex-approved products in potentially explosive atmospheres:

- Only use the product in accordance with the approved motor data.
- The Ex-approved product must never run dry during normal operation. Dry running during service and inspection is only permitted outside the classified area.
- Before you start work on the product, make sure that the product and the control panel are isolated from the power supply and the control circuit, so they cannot be energized.
- Do not open the product while it is energized or in an explosive gas atmosphere.
- Make sure that thermal contacts are connected to a protection circuit according to the approval classification of the product, and that they are in use.
- Intrinsically safe circuits are normally required for the automatic level-control system by the level regulator if mounted in zone 0.
- The yield stress of fasteners must be in accordance with the approval drawing and the product specification.
- Do not modify the equipment without approval from an authorized ITT representative.
- Only use parts that are provided by an authorized ITT representative.

Description of Ex-Directives

The Ex-directives are a specification enforced in Europe and the United Kingdom for electrical and non-electrical equipment installed in those locations. Ex-directives deal with the control of potentially explosive atmospheres and the standards of equipment and protective systems used within these atmospheres. The relevance of the Ex-requirements is not limited to Europe or the UK. You can apply these guidelines to equipment installed in any potentially explosive atmosphere.

Guidelines for compliance

Compliance is fulfilled only when you operate the unit within its intended use. Do not change the conditions of the service without the approval of an ITT representative. When you install or maintain explosion proof products, always comply with the directive and applicable standards (for example, IEC/EN 60079-14).

1. Monitoring the pump frame liquid end temperature.
2. Maintaining proper bearing lubrication.
3. Ensuring that the pump is operated in the intended hydraulic range.

The Ex conformance is only applicable when the pump unit is operated within its intended use. Operating, installing or maintaining the pump unit in any way that is not covered in the Instruction, Operation, and Maintenance manual (IOM) can cause serious personal injury or damage to the equipment. This

includes any modification to the equipment or use of parts not provided by ITT Goulds Pumps. If there is any question regarding the intended use of the equipment, please contact an ITT Goulds representative before proceeding.

Current IOMs are available at <https://www.gouldspumps.com/en-US/Tools-and-Resources/Literature/IOMs/> or from your local ITT Goulds Pumps Sales representative.

All pumping unit (pump, seal, coupling, motor and pump accessories) certified for use in an Ex classified environment, are identified by an Ex tag secured to the pump or the baseplate on which it is mounted. A typical tag would look like this:

If applicable, your pump may have either a CE Ex (ATEX) tag or UKCA Ex tag affixed to the pump. See the Safety section for a description of the symbols and codes. Typical nameplate only shown below, the actual area classification may be different.

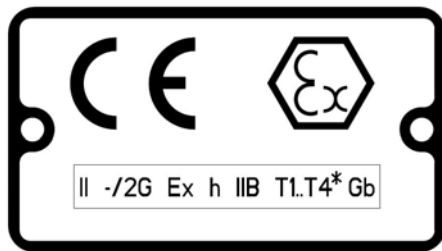

Figure 1: Typical Ex nameplate



Figure 2: Typical UKCA Ex nameplate

Table 1: Temperature class definitions

Code	Maximum permissible surface temperature in °C °F	Maximum permissible liquid temperature in °C °F
T1	440 824	372 700
T2	290 554	267 513
T3	195 383	172 342
T4	130 266	107 225
T5	Option not available	Option not available
T6	Option not available	Option not available

* Maximum liquid temperature may be limited by the pump model and order specific options. [Table 1: Temperature class definitions on page 12](#) is for the purpose of determining T'x' code for Ex applications with liquid temperatures exceeding 107°C | 225°F.

The code classification marked on the equipment must be in accordance with the specified area where the equipment will be installed. If it is not, do not operate the equipment and contact your ITT Goulds Pumps sales representative before proceeding.

ISO 80079-37:2016 Section 5.7

Recommended bearing replacement interval (based on L10 life) = 17,520 hours of operation.

Equipment for monitoring

For additional safety, use condition-monitoring devices. Condition-monitoring devices include but are not limited to these devices:

- Pressure gauges
- Flow meters
- Level indicators

- Motor load readings
- Temperature detectors
- Bearing monitors
- Leak detectors
- PumpSmart control system

**WARNING:**

- When pumping unit is installed in a potentially explosive atmosphere, the instructions after the Ex symbol must be followed. Personal injury and/or equipment damage may occur if these instructions are not followed. If there is any question regarding these requirements or if the equipment is to be modified, please contact a Goulds representative before proceeding.
- If equipment is to be installed in a potentially explosive atmosphere and these procedures are not followed, personal injury or equipment damage from an explosion may result.
- Particular care must be taken when the electrical power source to the equipment is energized.
- Improper impeller adjustment could cause contact between the rotating and stationary parts, resulting in a spark and heat generation.
- Lock out driver power to prevent electric shock, accidental start-up and physical injury.
- NEVER start pump without proper prime (all models), or proper liquid level in self-priming pumps (Model 3796 and SP3298).
- Equipment that will operate in a potentially explosive environment must be installed in accordance with the following instructions.
- All equipment being installed must be properly grounded to prevent unexpected static electric discharge. This includes ensuring that the PFA lined pumps (Model 3198), ETFE lined pumps (Model 3298, SP3298, V3298), and the non-metallic liquid end pumps (Model NM3196) are pumping fluids that are conductive. If not, a static electric discharge may occur when the pump is drained and disassembled for maintenance purposes.
- All equipment being installed must be properly grounded to prevent unexpected static electric discharge.
- When pumping fluids with conductivity less than 1000 ps/m follow IEC TS 60079 32-1 guidelines.
- Alignment procedures must be followed to prevent unintended contact of rotating parts. Follow coupling manufacturer's installation and operation procedures.
- When installing in a potentially explosive environment, ensure that the motor and accessories are properly certified.
- The impeller clearance setting procedure must be followed. Improperly setting the clearance or not following any of the proper procedures can result in sparks, unexpected heat generation and equipment damage.
- The impeller and wear ring clearance setting procedures must be followed. Improperly setting the clearance or not following any of the proper procedures can result in sparks, unexpected heat generation and equipment damage.
- Service temperature in an Ex classified environment is limited to the area classification specified on the Ex tag affixed to the pump (reference Table 1 in the Safety section for Ex classifications).
- The coupling used in an Ex classified environment must be properly certified.
- The coupling guard used in an Ex classified environment must be constructed from a spark-resistant material.

- Bearings must be lubricated properly in order to prevent excess heat generation, sparks and premature failure.
- The mechanical seal used in an Ex classified environment must be properly certified.
- The mechanical seal must have an appropriate seal flush system. Failure to do so will result in excess heat generation and seal failure.
- Packed stuffing boxes are not allowed in an Ex classified environment.
- Dynamic seals are not allowed in an Ex classified environment.
- Pumps that are not self-priming must be fully primed at all times during operation. The only model lines that are self-priming is the 3796 and SP3298.
- Pumps must be fully primed at all times during operation.
- The preventive maintenance section must be adhered to in order to keep the applicable Ex classification of the equipment. Failure to follow these procedures will void the Ex classification for the equipment. Bearing replacement intervals are given in the specific pump model IOM.
- Inspection intervals should be shortened appropriately if the pumpage is abrasive and/or corrosive, or if the environment is classified as potentially explosive.
- Throughout this section on bearing lubrication, different pumpage temperatures are listed. If the equipment is Ex certified and the listed temperature exceeds the applicable value shown in Table 1 under SAFETY, then that temperature is not valid. Should this situation occur, please consult with your ITT/Goolds representative.
- Cooling systems, such as those for bearing lubrication, mechanical seal systems, etc., where provided, must be operating properly to prevent excess heat generation, sparks and premature failure.
- Rotate shaft by hand to ensure it rotates smoothly and there is no rubbing which could lead to excess heat generation, sparks and premature failure.
- Flange loads from the piping system, including those from thermal expansion of the piping, must not exceed the limits of the pump. Casing deformation can result in contact with rotating parts which can result in excess heat generation, sparks and premature failure.
- Ensure that pump and systems are free of foreign objects before operating and that objects cannot enter the pump during operation. Foreign objects in the pumpage or piping system can cause blockage of flow which can result in excess heat generation, sparks and premature failure.
- Do not insulate or allow the bearing housings to accumulate a dust layer as this can result in excess heat generation, sparks and premature failure.
- Check for magnetism on the pump shaft and demagnetize the shaft if there is any detectable magnetism. Magnetism will attract ferritic objects to the impeller, seals and bearings which can result in excess heat generation, sparks and premature failure.
- Leakage of process liquid may result in creation of an explosive atmosphere. Ensure the materials of the pump casing, impeller, shaft, sleeves, gaskets and seals are compatible with the process liquid.
- Leakage of process liquid may result in creation of an explosive atmosphere. Follow all pump and seal assembly procedures.
- A buildup of gases within the pump, sealing system and or process piping system may result in an explosive environment within the pump or process piping system. Ensure process piping system, pump and sealing system are properly vented prior to operation.
- Sealing systems that are not self purging or self venting, such as plan 23, require manual venting prior to operation. Failure to do so will result in excess heat generation and seal failure.
- Do not apply additional paint or coatings to the pump when in an Ex environment. Static electric discharge can be initiated when contacting or rubbing surfaces with excessive coating thickness.

- Potential electrostatic charging hazard. Do not rub, clean, or blast equipment with dry cloth or dry media.
 - Stray electrical currents may ignite explosive atmospheres. Ensure drives are certified for variable frequency drive operation by the manufacturer.
 - User shall observe necessity of using a safety device, such as a flame arrestor, to prevent flame entering or leaving the pump sump, tank, or barrel when applicable.
 - For variable speed motor applications, the electric motor must be specified with shaft grounding and used with a conductive type coupling suitable for the area classification.
 - In plants or pumps with cathodic corrosion protection, a small current constantly flows through the construction. This is not permissible on the complete pump or partially-assembled machinery without further precautions being taken. ITT should be consulted in this context.
 - Move equipment to a safe/non Ex environment for repairs/adjustments or use spark resistant tools and work methods.
-

2 Transportation and Storage

2.1 Inspect the delivery

2.1.1 Inspect the package

1. Inspect the package for damaged or missing items upon delivery.
2. Note any damaged or missing items on the receipt and freight bill.
3. File a claim with the shipping company if anything is out of order.
If the product has been picked up at a distributor, make a claim directly to the distributor.

2.1.2 Inspect the unit

1. Remove packing materials from the product.
Dispose of all packing materials in accordance with local regulations.
2. Inspect the product to determine if any parts have been damaged or are missing.
3. If applicable, unfasten the product by removing any screws, bolts, or straps.
For your personal safety, be careful when you handle nails and straps.
4. Contact your sales representative if anything is out of order.

2.2 Transportation guidelines

2.2.1 Pump handling



WARNING:

Dropping, rolling or tipping units, or applying other shock loads, can cause property damage and/or personal injury. Ensure that the unit is properly supported and secure during lifting and handling.



CAUTION:

Risk of injury or equipment damage from use of inadequate lifting devices. Ensure lifting devices (such as chains, straps, forklifts, cranes, etc.) are rated to sufficient capacity.

2.2.2 Lifting methods



WARNING:

- Risk of serious personal injury or equipment damage. Proper lifting practices are critical to safe transport of heavy equipment. Ensure that practices used are in compliance with all applicable regulations and standards.
 - Safe lifting points are specifically identified in this manual. It is critical to lift the equipment only at these points. Integral lifting eyes or eye bolts on pump and motor components are intended for use in lifting the individual components only.
 - Lifting and handling heavy equipment poses a crush hazard. Use caution during lifting and handling and wear appropriate Personal Protective Equipment (PPE, such as steel-toed shoes, gloves, etc.) at all times. Seek assistance if necessary.
-

Table 2: Methods

Pump type	Lifting method
Bare pump without lifting handles	Use a suitable sling attached properly to solid points like the casing, the flanges, or the frames.
A bare pump with lifting handles	Lift the pump by the handles.
A base-mounted pump	Use slings under the pump casing and the drive unit, or under the base rails.

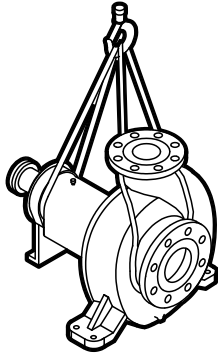
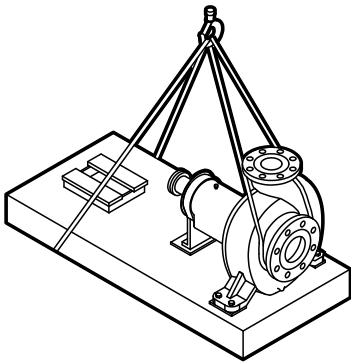
Examples**Figure 3: Example of a proper lifting method****Figure 4: Example of a proper lifting method****NOTICE:**

Do not use this method to lift a Polyshield ANSI Combo with the pump and motor mounted. These items are not designed to handle the heavy weight of the Polyshield system. Doing so may result in equipment damage.

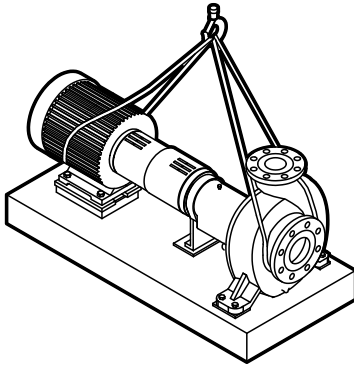

Figure 5: Example of a proper lifting method

NOTICE:

Do not use this method to lift a Polyshield ANSI Combo with the pump and motor mounted. These items are not designed to handle the heavy weight of the Polyshield system. Doing so may result in equipment damage.

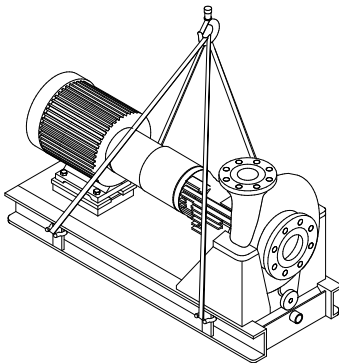

Figure 6: Example of a proper lifting method

NOTICE:

When lifting a unit for which a strap cannot be secured at the suction flange, secure the strap through the frame/frame adapter. Securing at the frame adapter will prevent slipping of the strap and possible equipment damage.

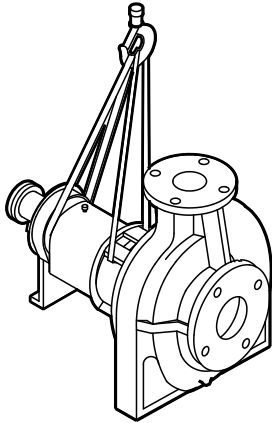

Figure 7: Example of a proper lifting method with a strap secured around the frame adapter

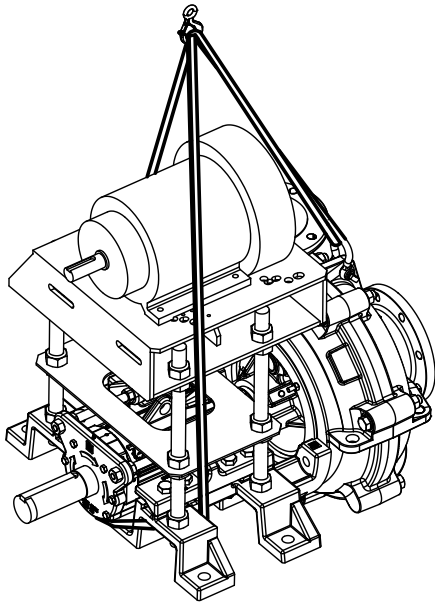

Figure 8: Example of offset overhead motor mount pump proper lifting method

2.3 Storage guidelines

2.3.1 Pump storage requirements

Storage requirements depend on the amount of time that you store the unit. The normal packaging is designed only to protect the unit during shipping.

Length of time in storage	Storage requirements
Upon receipt/short-term (less than six months)	<ul style="list-style-type: none"> • Store in a covered and dry location. • Store the unit free from dirt and vibrations.
Long-term (more than six months)	<ul style="list-style-type: none"> • Store in a covered and dry location. • Store the unit free from heat, dirt, and vibrations. • Rotate the shaft by hand several times at least every three months.

Treat bearing and machined surfaces so that they are well preserved. Refer to drive unit and coupling manufacturers for their long-term storage procedures.

2.3.2 Frostproofing

Table 3: Situations when the pump is or is not frostproof

Situation	Condition
Operating	The pump is frostproof.
Immersed in a liquid	The pump is frostproof.
Lifted out of a liquid into a temperature below freezing	The impeller might freeze.

3 Product Description

3.1 General description NM 3196

The NM 3196 is a horizontal overhung, open impeller, centrifugal pump. This pump is ANSI B73.1 compliant. It is made of a fiber-reinforced vinylester to handle severe corrosives.

The model is based on 2 power ends and 13 hydraulic sizes.



Figure 9: NM 3196 pump



Figure 10: NM 3196 pump

This table shows the number of hydraulic sizes available for each drive-unit size group.

Pump size group	Number of hydraulic sizes
STX	5
STi	
MTX	8
MTi	



WARNING:

Use of equipment unsuitable for the environment can pose risks of ignition and/or explosion. Ensure the pump driver and all other auxiliary components meet the required area classification at the site. If they are not compatible, do not operate the equipment and contact an ITT representative before proceeding.

3.1.1 Part description NM 3196

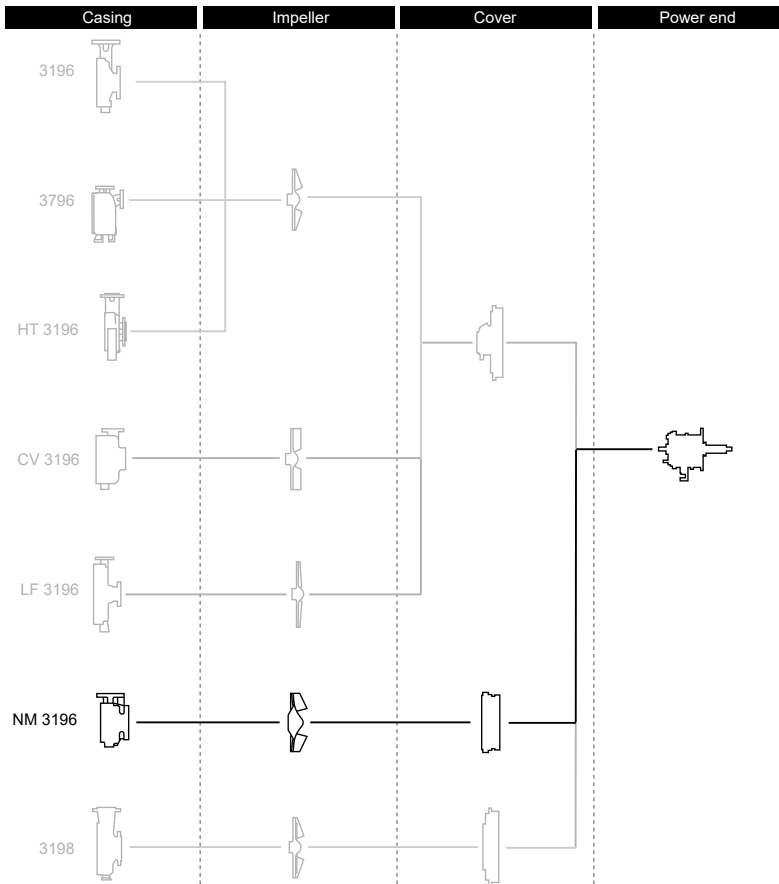

Figure 11: NM 3196 part description

Table 4: Casing

This table describes the pump casing parts.

Part	Description
Discharge	Top-centerline
Casing ventilation	Self venting
Sealing	Viton O-ring
Mounting method	Integral foot support for maximum resistance to misalignment and distortion due to piping loads.
Standard flange	ANSI class 150 flat-face flange
Construction material	Fiber-reinforced vinylester, ribbed for strength

Impeller

The impeller is

- fully open
- screwed onto the shaft
- made of fiber-reinforced vinylester cast on an insert made of Hastelloy C. The insert provides threads and the support and rigidity needed to mount the impeller.

The threads are sealed from the pumped liquid by a PTFE O-ring.

Cover

The NM 3196 is supplied with a/an

Standard cover

- a fiber-reinforced vinylester cover to fit a clamped outside single seal.

Optional Cover

- the backplate is also available with an internal bypass flush.
- a bolt-on seal chamber is available for conventional back-to-back double seals.

Table 5: Power end

This table describes the main parts of the power end.

Part	Description
Frame adapter	The ductile iron frame adapter has <ul style="list-style-type: none"> • a machined rabbet fit to the seal chamber/ stuffing box cover • a precision dowel pin fit to the bearing frame.
Power end	<ul style="list-style-type: none"> • Flood-oil lubrication is standard. • Oil-mist, regreasable and greased-for-life options are available. • The oil level is checked through a sight glass. • The power end is sealed with labyrinth seals. • The power end is made in the following sizes: <ul style="list-style-type: none"> • STi • MTi
Shaft	The shaft is available with or without a sleeve.
Bearings	<p>The inboard bearing</p> <ul style="list-style-type: none"> • carries only radial loads. • is free to float axially in the frame. • is a single-row deep-groove ball bearing <p>The outboard bearing</p> <ul style="list-style-type: none"> • is shouldered and locked to the shaft and housing to enable it to carry radial and thrust loads. • is a double-row angular-contact bearing.

3.2 General description i-ALERT® Equipment Health Monitor

Description

The i-ALERT® Equipment Health Monitor is a compact, battery-operated monitoring device that continuously measures the vibration and temperature of the pump power end. The i-ALERT® sensor uses blinking LED and wireless notification to alert the pump operator when the pump exceeds vibration and temperature limits. This allows the pump operator to make changes to the process or the pump before a

catastrophic failure occurs. The i-ALERT® monitor allows customers to identify potential problems before they become costly failures. It tracks vibration, temperature, change in electromagnetic field and run-time hours and wirelessly syncs the data with the i-ALERT Gateway or with a smart phone or tablet using i-ALERT® mobile app.

More information available on <https://www.i-alert.com/products/>

Current IOMs are available at <http://www.gouldspumps.com/en-us/tools-and-resources/literature/> - and - [resources/literature/](https://www.i-alert.com/) IOMs, <https://www.i-alert.com/> or your local ITT Goulds Pumps Sales Rep.

Alarm mode

The condition monitor enters alarm mode when either vibration or temperature limits are exceeded over two consecutive readings within a user defined period. Alarm mode is indicated with red flashing LED.

Table 6: Temperature and vibration limits

Variable	Limit
Temperature	100°C 195°F Surface Temperature
Vibration	100% increase over the baseline level

Battery life

The i-ALERT® Condition Monitor battery is replaceable.

The battery life is not covered as part of the standard pump warranty.

This table shows the average condition monitor battery life under normal and alarm-mode operating conditions.

Condition monitor operational state	Battery life
Normal operating and environmental conditions	Three to five years
Alarm mode	One year

3.3 Nameplate information

Important information for ordering

Every pump has nameplates that provide information about the pump. The nameplates are located on the casing and the bearing frame.

When you order spare parts, identify this pump information:

- Model
- Size
- Serial number
- Item numbers of the required parts

Item numbers can be found in the spare parts list.

Refer to the nameplate on the pump casing for most of the information. See Parts List for item numbers.

Nameplate types

Nameplate	Description
Pump casing	Provides information about the hydraulic characteristics of the pump.
Pump	The formula for the pump size is: Discharge x Suction - Nominal Maximum Impeller Diameter in inches. (Example: 2x3-8)

Nameplate	Description
Bearing frame	Provides information about the lubrication system used.
Ex	If applicable, your pump unit might have an Ex nameplate affixed to the pump, the baseplate, or the discharge head. The nameplate provides information about the Ex specifications of this pump.

Nameplate on the pump casing using English units

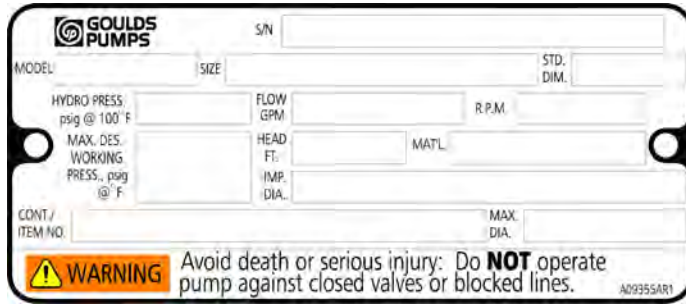

Figure 12: Nameplate on the pump casing using English units

Table 7: Explanation of nameplate on the pump casing

Nameplate field	Explanation
IMPLR. DIA.	Impeller diameter, in inches
MAX. DIA.	Maximum impeller diameter, in inches
GPM	Rated pump flow, in gallons per minute
FT HD	Rated pump head, in feet
RPM	Rated pump speed, revolutions per minute
MOD.	Pump model
SIZE	Size of the pump
STD. NO.	ANSI standard designation
MAT L. CONST.	Material of which the pump is constructed
SER. NO.	Serial number of the pump
MAX DSGN PSI @ 100°F	Maximum pressure at 100°F according to the pump design

Nameplate on the pump casing using metric units

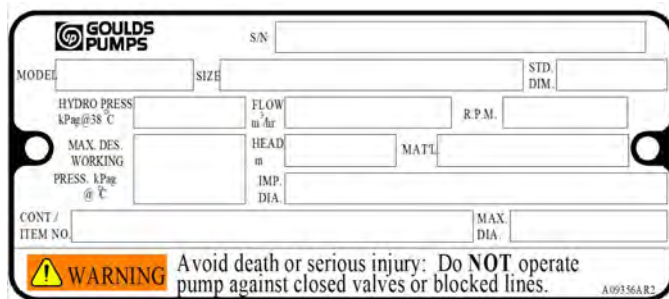

Figure 13: Metric units - nameplate on pump casing

Table 8: Explanation of the nameplate on the pump casing

Nameplate field	Explanation
IMPLR. DIA.	Impeller diameter

3.3 Nameplate information

Nameplate field	Explanation
MAX. DIA.	Maximum impeller diameter
M ³ /HR	Rated pump flow, in cubic meters per hour
M HD	Rated pump head, in meters
RPM	Rated pump speed, in revolutions per minute
MOD.	Pump model
SIZE	Size of the pump
STD. NO.	ANSI standard designation
MAT L. CONST	Material of which the pump is constructed
SER. NO.	Serial number of the pump
MAX. DSGN kPag @ 20°C	Kilopascal at 20°C

Nameplate on the bearing frame

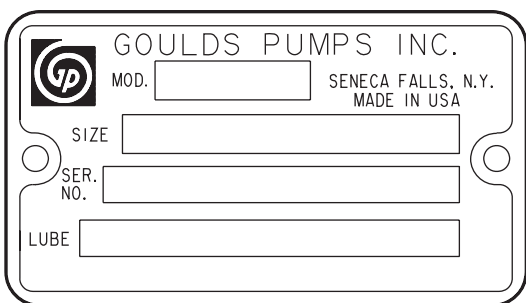

Figure 14: Nameplate on the bearing frame

Table 9: Explanation of the nameplate on the bearing frame

Nameplate field	Explanation
BRG. O. B.	Outboard bearing designation
BRG. I. B.	Inboard bearing designation
S/N	Serial number of the pump
LUBE	Lubricant, oil or grease

Ex nameplate

All pumping unit (pump, seal, coupling, motor and pump accessories) certified for use in an Ex classified environment, are identified by an Ex tag secured to the pump or baseplate on which it is mounted. A typical tag would look like this:



Figure 15: Typical Ex nameplate



Figure 16: Typical UKCA Ex nameplate

ISO 80079-37:2016 Section 5.7

Recommended bearing replacement interval (based on L10 life) = 17,520 hours of operation.

The code classification marked on the equipment should be in accordance with the specified area where the equipment will be installed. If it is not, please contact your ITT/Goulds representative before proceeding.



WARNING:

Use of equipment unsuitable for the environment can pose risks of ignition and/or explosion. Ensure the pump driver and all other auxiliary components meet the required area classification at the site. If they are not compatible, do not operate the equipment and contact an ITT representative before proceeding.

4 Installation

4.1 Pre-installation

Precautions



WARNING:

- When installing in a potentially explosive environment, ensure that the motor is properly certified.
- All equipment being installed must be properly grounded to prevent unexpected discharge. Discharge can cause equipment damage, electric shock, and result in serious injury. Test the ground lead to verify it is connected correctly.

NOTICE:

- Electrical connections must be made by certified electricians in compliance with all international, national, state and local regulations.
- Supervision by an authorized ITT representative is recommended to ensure proper installation. Improper installation may result in equipment damage or decreased performance.

4.1.1 Pump location guidelines

Guideline	Explanation/comment
Keep the pump as close to the liquid source as practically possible.	This minimizes the friction loss and keeps the suction piping as short as possible.
Make sure that the space around the pump is sufficient.	This facilitates ventilation, inspection, maintenance, and service.
If you require lifting equipment such as a hoist or tackle, make sure that there is enough space above the pump.	This makes it easier to properly use the lifting equipment and safely remove and relocate the components to a safe location.
Protect the unit from weather and water damage due to rain, flooding, and freezing temperatures.	This is applicable if nothing else is specified.
Do not install and operate the equipment in closed systems unless the system is constructed with properly-sized safety devices and control devices.	Acceptable devices: <ul style="list-style-type: none"> • Pressure relief valves • Compression tanks • Pressure controls • Temperature controls • Flow controls If the system does not include these devices, consult the engineer or architect in charge before you operate the pump.
Take into consideration the occurrence of unwanted noise and vibration.	The best pump location for noise and vibration absorption is on a concrete floor with subsoil underneath.
If the pump location is overhead, undertake special precautions to reduce possible noise transmission.	Consider a consultation with a noise specialist.

4.1.2 Foundation requirements

Precautions



WARNING:

Risk of serious injury or death in Ex-classified environments. If the pump is a Model NM3171, NM3196, 3198, CV3198, 3298, V3298, SP3298, 4150, 4550, or 3107, ignition due to static electric discharge is possible from plastic parts that are not properly grounded. If the pumped fluid is non-conductive, drain and flush the pump with a conductive fluid under conditions that will not allow for a spark to be released to the atmosphere.

Requirements

- The location and size of the foundation bolt holes must match those shown on the assembly drawing provided with the pump data package.
- The foundation must weigh between two and three times the weight of the pump.
- Provide a flat, substantial concrete foundation in order to prevent strain and distortion when you tighten the foundation bolts.
- Sleeve-type and J-type foundation bolts are most commonly used. Both designs allow movement for the final bolt adjustment.

Sleeve-type bolts

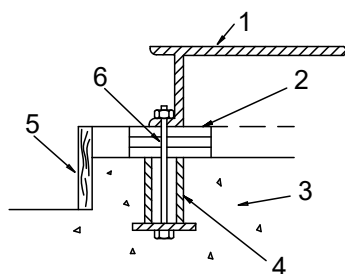

Item	Description
1.	Baseplate
2.	Shims
3.	Foundation
4.	Sleeve
5.	Dam
6.	Bolt

Figure 17: Sleeve type bolts

J-type bolts

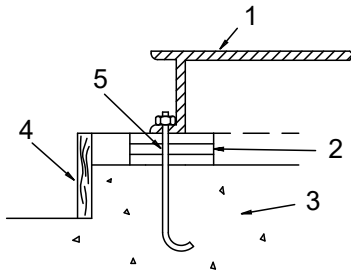

Item	Description
1.	Baseplate
2.	Shims or wedges
3.	Foundation
4.	Dam
5.	Bolt

Figure 18: J-type bolts

4.2 Baseplate-mounting procedures

4.2.1 Prepare the baseplate for mounting

1. Remove all the attached equipment from the baseplate.
2. Clean the underside of the baseplate completely.
3. If applicable, coat the underside of the baseplate with an epoxy primer.
Use an epoxy primer only if using an epoxy-based grout.
4. Remove the rust-proofing coat from the machined mounting pads using an appropriate solvent.
5. Remove water and debris from the foundation-bolt holes.

4.2.2 Install the baseplate using shims or wedges

Required tools:

- Two sets of shims or wedges for each foundation bolt
- Two machinist's levels
- Baseplate-leveling worksheet

This procedure is applicable to cast iron and fabricated steel baseplates.

1. If you use sleeve-type bolts, fill the bolt sleeves with packing material or rags to prevent grout from entering the bolt holes.
2. Put the sets of wedges or shims on each side of each foundation bolt.
The sets of wedges should have a height of between 19 mm | 0.75 in. and 38 mm | 1.50 in.

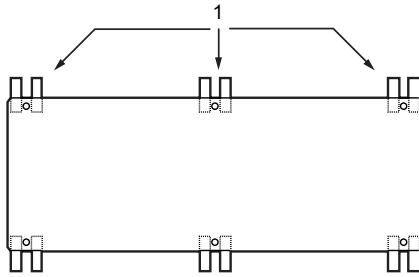

1. Shims or wedges

Figure 19: Top view

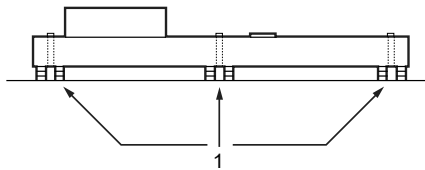

1. Shims or wedges

Figure 20: Side view

3. Lower the baseplate carefully onto the foundation bolts.
4. Put the machinist's levels across the mounting pads of the driver and the mounting pads of the pump.

NOTICE:

Remove all dirt from the mounting pads in order to ensure that the correct leveling is achieved. Failure to do so can result in equipment damage or decreased performance.

5. Level the baseplate both lengthwise and across by adding or removing shims or moving the wedges.

These are the leveling tolerances:

- A maximum difference of 3.2 mm | 0.125 in. lengthwise
- A maximum difference of 1.5 mm | 0.059 in. across

You can use the baseplate-leveling worksheet when you take the readings.

6. Hand-tighten the nuts for the foundation.

4.2.3 Install the baseplate using jackscrews

Tools required:

- Anti-seize compound
- Jackscrews
- Bar stock
- Two machinist's levels
- Baseplate-leveling worksheet

This procedure is applicable to the feature-fabricated steel baseplate and the advantage base baseplate.

1. Apply an anti-seize compound on the jackscrews.
The compound makes it easier to remove the screws after you grout.
2. Lower the baseplate carefully onto the foundation bolts and perform these steps:

- a) Cut the plates from the bar stock and chamfer the edges of the plates in order to reduce stress concentrations.
- b) Put the plates between the jackscrews and the foundation surface.
- c) Use the four jackscrews in the corners in order to raise the baseplate above the foundation. Make sure that the distance between the baseplate and the foundation surface is between 19 mm | 0.75 in. and 38 mm | 1.50 in.
- d) Make sure that the center jackscrews do not touch the foundation surface yet.

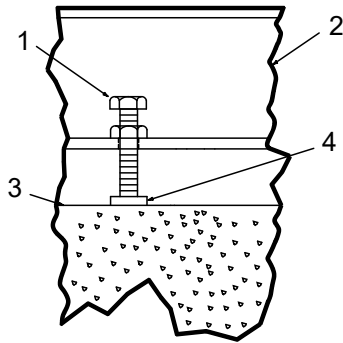

Item	Description
1.	Jackscrew
2.	Baseplate
3.	Foundation
4.	Plate

Figure 21: Jackscrews

3. Level the driver mounting pads:

NOTICE:

Remove all dirt from the mounting pads in order to ensure that the correct leveling is achieved. Failure to do so can result in equipment damage or decreased performance.

- a) Put one machinist's level lengthwise on one of the two pads.
- b) Put the other machinist's level across the ends of the two pads.
- c) Level the pads by adjusting the four jackscrews in the corners. Make sure that the machinist's level readings are as close to zero as possible, both lengthwise and across.

Use the baseplate-leveling worksheet when you take the readings.

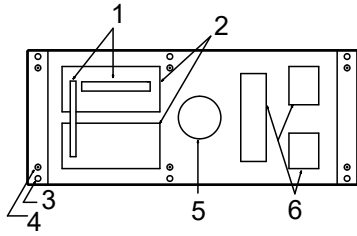

Item	Description
1.	Machinist's levels
2.	Driver's mounting pads
3.	Foundation bolts
4.	Jackscrews
5.	Grout hole
6.	Pump's mounting pads

Figure 22: Level driver mounting pads

4. Turn the center jackscrews down so that they rest on their plates on the foundation surface.
5. Level the pump mounting pads:

NOTICE:

Remove all dirt from the mounting pads in order to ensure that the correct leveling is achieved. Failure to do so can result in equipment damage or decreased performance.

- a) Put one machinist's level lengthwise on one of the two pads.
 - b) Put the other level across the center of the two pads.
 - c) Level the pads by adjusting the four jackscrews in the corners.
- Make sure that the machinist's level readings are as close to zero as possible, both lengthwise and across.

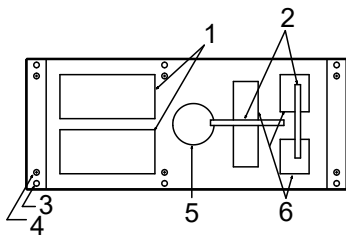

Item	Description
1.	Driver's mounting pads
2.	Machinist's levels
3.	Foundation bolts
4.	Jackscrews
5.	Grout hole
6.	Pump's mounting pads

Figure 23: Level pump mounting pads

6. Hand-tighten the nuts for the foundation bolts.

7. Check that the driver's mounting pads are level and adjust the jackscrews and the foundation bolts if necessary.

The correct level measurement is a maximum of 0.167 mm/m | 0.002 in./ft .

4.2.4 Install the baseplate using spring mounting

NOTICE:

The spring-mounted baseplate is designed only to support piping loads from thermal expansion. Ensure that the suction and discharge piping are supported individually. Failure to do so may result in equipment damage.

The foundation pads are not provided with the baseplate. Make sure that the foundation pads are 316 stainless-steel plates, which have a 16-20 micro-inch surface finish.

Before you start this procedure, make sure that the foundation pads are correctly installed on the foundation/floor (see the manufacturer's instructions).

1. Put the baseplate on a support above the foundation/floor.
Make sure that there is enough space between the baseplate and the foundation/floor in order to install the spring assemblies.
2. Install the lower part of the spring assembly:
 - a) Screw the lower jam nut onto the spring stud.
 - b) Screw the lower adjusting nut onto the spring-stud, on top of the jam nut.
 - c) Set the lower adjusting nut to the correct height.
The correct height depends on the required distance between the foundation/floor and the baseplate.
 - d) Put a washer, a follower, a spring, and one more follower onto the lower adjusting nut.
3. Install the spring assembly on the baseplate:
 - a) Insert the spring assembly into the baseplate's anchorage hole from below.
 - b) Put a follower, a spring, another follower, and a washer onto the spring stud.
 - c) Fasten the spring assembly with the upper adjusting nut by hand.
4. Thread the upper jam nut onto the spring stud by hand.
5. Repeat steps 2 through 4 for all the spring assemblies.
6. Lower the baseplate so that the spring assemblies fit into the foundation pads.
7. Level the baseplate and make the final height adjustments:
 - a) Loosen the upper jam nuts and adjusting nuts.
 - b) Adjust the height and level the baseplate by moving the lower adjusting nuts.
 - c) When the baseplate is level, tighten the top adjusting nuts so that the top springs are not loose in their followers.
8. Fasten the lower and upper jam nuts on each spring assembly.

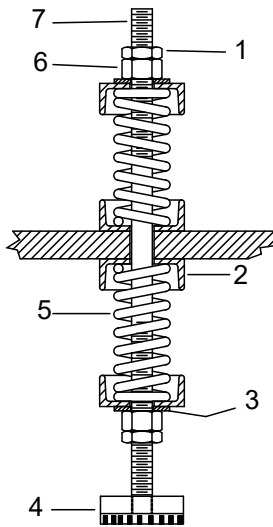

1. Upper jam nut
2. Follower
3. Washer
4. Foundation pads
5. Spring
6. Upper adjusting nut
7. Spring stud

Figure 24: Example of an installed spring assembly

4.2.5 Install the baseplate using stilt mounting

NOTICE:

The stilt-mounted baseplate is not designed to support static piping loads. Ensure that the suction and discharge piping are supported individually. Failure to do so may result in equipment damage.

1. Put the baseplate on a support above the foundation/floor.
Make sure that there is enough space between the baseplate and the foundation/floor to install the stilts.
2. Install the lower part of the stilt assembly:
 - a) Screw the lower jam nut and adjusting nut onto the stilt.
 - b) Set the lower adjusting nut to the correct height.
The correct height depends on the required distance between the foundation/floor and the baseplate.
 - c) Put a washer onto the lower adjusting- nut.
3. Install the stilt assembly on the baseplate:
 - a) Insert the stilt assembly into the baseplate's anchorage hole from below.
 - b) Put a washer onto the stilt.
 - c) Fasten the stilt assembly with the upper adjusting nut by hand.
4. Screw the upper jam nut onto the stilt by hand.
5. Repeat steps 2 through 4 for all the stilt assemblies.

6. Lower the baseplate so that the stilts fit into the foundation cups.
7. Level the baseplate and make the final height adjustments:
 - a) Loosen the upper jam nuts and adjusting nuts.
 - b) Adjust the height and level the baseplate by moving the lower adjusting nuts.
 - c) When the baseplate is level, tighten the top adjusting nuts.
8. Fasten the lower and upper jam nuts on each stilt.

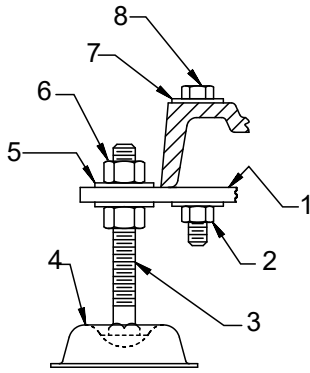

1. Mounting plate
2. Mounting nut
3. Stilt bolt
4. Foundation cups
5. Washer
6. Upper adjustment nut
7. Mounting washer
8. Mounting bolt

Figure 25: Example of an installed stilt assembly

4.2.6 Baseplate-leveling worksheet

Level measurements

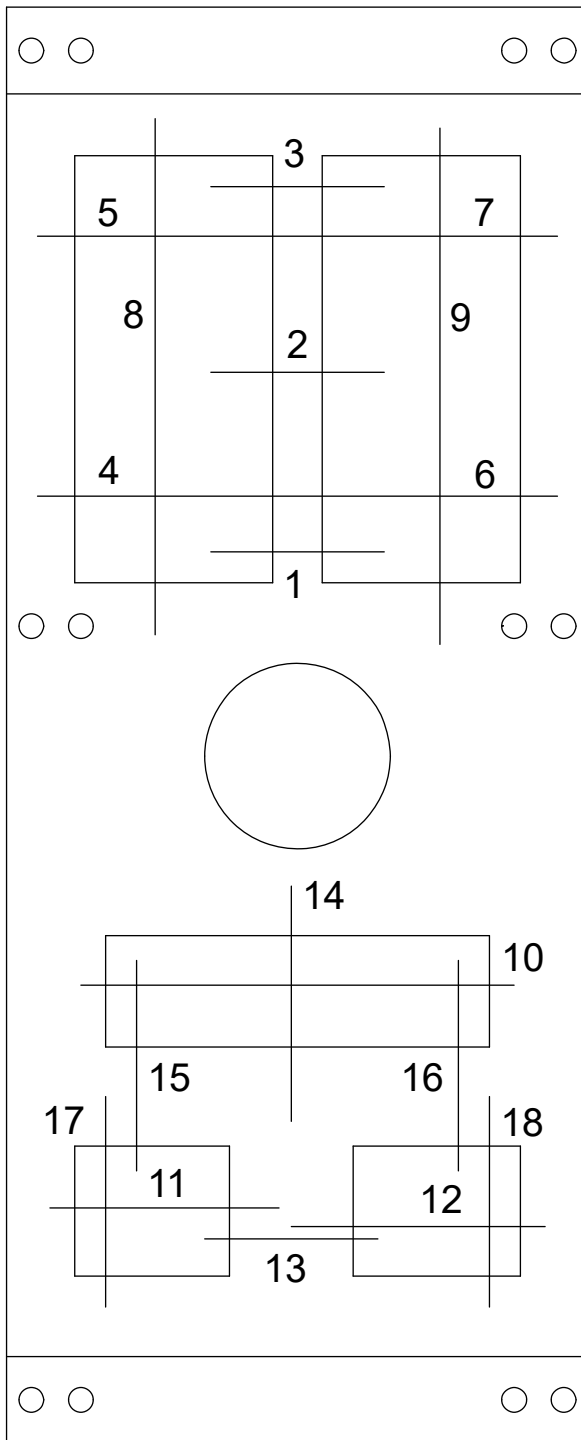

- 1) _____
- 2) _____
- 3) _____
- 4) _____
- 5) _____
- 6) _____
- 7) _____
- 8) _____
- 9) _____
- 10) _____
- 11) _____
- 12) _____
- 13) _____
- 14) _____
- 15) _____
- 16) _____
- 17) _____
- 18) _____

4.3 Install the pump, driver, and coupling

1. Mount and fasten the pump on the baseplate. Use applicable bolts.
2. Mount the driver on the baseplate. Use applicable bolts and hand tighten.
3. Install the coupling.
See the installation instructions from the coupling manufacturer.

4.4 Pump-to-driver alignment

Precautions



WARNING:

- Misalignment can cause decreased performance, equipment damage, and even catastrophic failure of frame-mounted units leading to serious injury. Proper alignment is the responsibility of the installer and the user of the unit. Check the alignment of all drive components prior to operating the unit.
 - Follow the coupling installation and operation procedures from the coupling manufacturer.
- Failure to disconnect and lock out driver power may result in serious physical injury or death. Always disconnect and lock out power to the driver before performing any installation or maintenance tasks.
 - Electrical connections must be made by certified electricians in compliance with all international, national, state, and local rules.
 - Refer to driver/coupling/gear manufacturer's installation and operation manuals (IOM) for specific instructions and recommendations.

4.4.1 Alignment checks

When to perform alignment checks

You must perform alignment checks under these circumstances:

- The process temperature changes.
- The piping changes.
- The pump has been serviced.

Types of alignment checks

Type of check	When it is used
Initial alignment (cold alignment) check	Prior to operation when the pump and the driver are at ambient temperature.
Final alignment (hot alignment) check	After operation when the pump and the driver are at operating temperature.

Initial alignment (cold alignment) checks

When	Why
Before you grout the baseplate	This ensures that alignment can be accomplished.
After you grout the baseplate	This ensures that no changes have occurred during the grouting process.
After you connect the piping	This ensures that pipe strains have not altered the alignment. If changes have occurred, you must alter the piping to remove pipe strains on the pump flanges.

Final alignment (hot alignment) checks

When	Why
After the first run	This ensures correct alignment when both the pump and the driver are at operating temperature.
Periodically	This follows the plant operating procedures.

4.4.2 Permitted indicator values for alignment checks

NOTICE:

The specified permitted reading values are valid only at operating temperature. For cold settings, other values are permitted. The correct tolerances must be used. Failure to do so can result in misalignment. Contact ITT for further information.

When dial indicators are used to check the final alignment, the pump and drive unit are correctly aligned when these conditions are true:

- The Total Indicated Reading (T.I.R.) is at 0.05 mm | 0.002 in. or less at operating temperature.
- The tolerance of the indicator is 0.0127 mm per mm | 0.0005 in. per in. of indicator separation for the reverse dial indicator or laser method when the pump and driver are at operating temperature.

4.4.2.1 Cold settings for parallel vertical alignment

Introduction

This section shows the recommended preliminary (cold) settings for electric motor-driven pumps based on different temperatures of pumped fluid. Consult driver manufacturers for recommended cold settings for other types of drivers such as steam turbines and engines.

Recommended settings for model NM 3196

Pump temperature	Recommended setting
10°C 50°F	0.05 mm 0.002 in., low
65°C 150°F	0.03 mm 0.001 in., high
120°C 250°F	0.12 mm 0.005 in., high
175°C 350°F	Not applicable
232°C 450°F	Not applicable
288°C 550°F	Not applicable
343°C 650°F	Not applicable
371°C 700°F	Not applicable

4.4.3 Alignment measurement guidelines

Guideline	Explanation
Rotate the pump coupling half and the driver coupling half together so that the indicator rods have contact with the same points on the driver coupling half.	This prevents incorrect measurement.
Move or shim only the driver in order to make adjustments.	This prevents strain on the piping installations.
Make sure that the hold-down bolts for the driver are tight when you take indicator measurements.	This keeps the driver stationary since movement causes incorrect measurement.
Make sure that the hold-down bolts for the driver are loose before you make alignment corrections.	This makes it possible to move the driver when you make alignment corrections.

Guideline	Explanation
Check the alignment again after any mechanical adjustments.	This corrects any misalignments that an adjustment may have caused.

4.4.4 Attach the dial indicators for alignment

You must have two dial indicators in order to complete this procedure.

1. Attach two dial indicators on the pump coupling half (X):
 - a) Attach one indicator (P) so that the indicator rod comes into contact with the perimeter of the driver coupling half (Y).
This indicator is used to measure parallel misalignment.
 - b) Attach the other indicator (A) so that the indicator rod comes into contact with the inner end of the driver coupling half.
This indicator is used to measure angular misalignment.

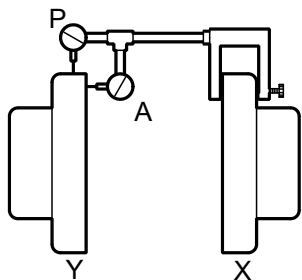

Figure 26: Dial indicator attachment

2. Rotate the pump coupling half (X) in order to check that the indicators are in contact with the driver coupling half (Y) but do not bottom out.
3. Adjust the indicators if necessary.

4.4.5 Pump-to-driver alignment instructions

4.4.5.1 Perform angular alignment for a vertical correction

1. Set the angular alignment indicator to zero at the top-center position (12 o'clock) of the driver coupling half (Y).
2. Rotate the indicator to the bottom-center position (6 o'clock).
3. Record the indicator reading.

When the reading value is...	Then...
Negative	The coupling halves are farther apart at the bottom than at the top. Perform one of these steps: <ul style="list-style-type: none"> • Add shims in order to raise the feet of the driver at the shaft end. • Remove shims in order to lower the feet of the driver at the other end.
Positive	The coupling halves are closer at the bottom than at the top. Perform one of these steps: <ul style="list-style-type: none"> • Remove shims in order to lower the feet of the driver at the shaft end. • Add shims in order to raise the feet of the driver at the other end.

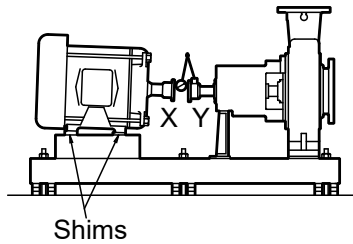

Figure 27: Side view of an incorrect vertical alignment

4. Repeat the previous steps until the permitted reading value is achieved.

4.4.5.2 Perform angular alignment for a horizontal correction

1. Set the angular alignment indicator (A) to zero on left side of the driver coupling half (Y), 90° from the top-center position (9 o'clock).
2. Rotate the indicator through the top-center position to the right side, 180° from the start position (3 o'clock).
3. Record the indicator reading.

When the reading value is...	Then...
Negative	The coupling halves are farther apart on the right side than the left. Perform one of these steps: <ul style="list-style-type: none"> • Slide the shaft end of the driver to the left. • Slide the opposite end to the right.
Positive	The coupling halves are closer together on the right side than the left. Perform one of these steps: <ul style="list-style-type: none"> • Slide the shaft end of the driver to the right. • Slide the opposite end to the left.

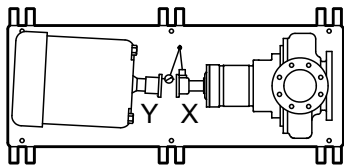

Figure 28: Top view of an incorrect horizontal alignment

4. Repeat the previous steps until the permitted reading value is achieved.

Maximum permitted value for angular alignment:

4.4.5.3 Perform parallel alignment for a vertical correction

Refer to the alignment table in "Permitted indicator values for alignment checks" (see Table of Contents for location of table) for the proper cold alignment value based on the motor temperature rise and the pump operating temperature.

Before you start this procedure, make sure that the dial indicators are correctly set up.

A unit is in parallel alignment when the parallel indicator (P) does not vary by more than 0.05 mm | 0.002 in. as measured at four points 90° apart at the operating temperature.

1. Set the parallel alignment indicator (P) to zero at the top-center position (12 o'clock) of the driver coupling half (Y).

2. Rotate the indicator to the bottom-center position (6 o'clock).
3. Record the indicator reading.

When the reading value is...	Then...
Negative	The pump coupling half (X) is lower than the driver coupling half (Y). Remove shims of a thickness equal to half of the indicator reading value under each driver foot.
Positive	The pump coupling half (X) is higher than the driver coupling half (Y). Add shims of a thickness equal to half of the indicator reading value to each driver foot.

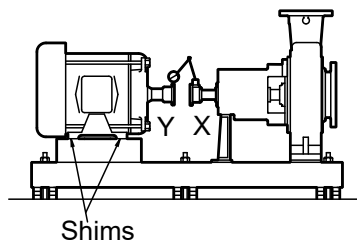

Figure 29: Side view of an incorrect vertical alignment

4. Repeat the previous steps until the permitted reading value is achieved.

NOTICE:

The specified permitted reading values are valid only at operating temperature. For cold settings, other values are permitted. The correct tolerances must be used. Failure to do so can result in misalignment. Contact ITT for further information.

4.4.5.4 Perform parallel alignment for a horizontal correction

Refer to the alignment table in "Permitted indicator values for alignment checks" (see Table of Contents for location of table) for the proper cold alignment value based on the motor temperature rise and the pump operating temperature.

A unit is in parallel alignment when the parallel indicator (P) does not vary by more than 0.05 mm | 0.002 in. as measured at four points 90° apart at the operating temperature.

1. Set the parallel alignment indicator (P) to zero on the left side of the driver coupling half (Y), 90° from the top-center position (9 o'clock).
2. Rotate the indicator through the top-center position to the right side, 180° from the start position (3 o'clock).
3. Record the indicator reading.

When the reading value is...	Then...
Negative	The driver coupling half (Y) is to the left of the pump coupling half (X).
Positive	The driver coupling half (Y) is to the right of the pump coupling half (X).

4. Slide the driver carefully in the appropriate direction.

NOTICE:

Make sure to slide the driver evenly. Failure to do so can negatively affect horizontal angular correction.

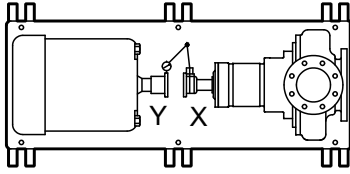

Figure 30: Top view of an incorrect horizontal alignment

5. Repeat the previous steps until the permitted reading value is achieved.

NOTICE:

The specified permitted reading values are valid only at operating temperature. For cold settings, other values are permitted. The correct tolerances must be used. Failure to do so can result in misalignment. Contact ITT for further information.

4.4.5.5 Perform complete alignment for a vertical correction

A unit is in complete alignment when both the angular indicator (A) and the parallel indicator (P) do not vary by more than 0.05 mm | 0.002 in. as measured at four points 90° apart.

1. Set the angular and parallel dial indicators to zero at the top-center position (12 o'clock) of the driver coupling half (Y).
2. Rotate the indicators to the bottom-center position (6 o'clock).
3. Record the indicator readings.
4. Make corrections according to the separate instructions for angular and parallel alignment until you obtain the permitted reading values.

4.4.5.6 Perform complete alignment for a horizontal correction

A unit is in complete alignment when both the angular indicator (A) and the parallel indicator (P) do not vary by more than 0.05 mm | 0.002 in. as measured at four points 90° apart.

1. Set the angular and parallel dial indicators to zero at the left side of the driver coupling half (Y), 90° from the top-center position (9 o'clock).
2. Rotate the indicators through the top-center position to the right side, 180° from the start position (3 o'clock).
3. Record the indicator readings.
4. Make corrections according to the separate instructions for angular and parallel alignment until you obtain the permitted reading values.

4.4.6 C-face adapter

Intended use

The C-face adapter is a device that attaches the pump to the drive unit to minimize the axial and radial play between the two coupling halves.

Illustration

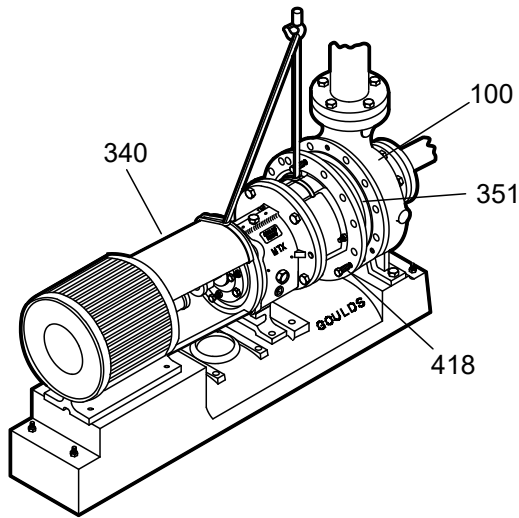

Figure 31: Example of the C-face adapter (340)

Alignment requirements

When you use a C-face adapter, you do not have to align the shaft. The rabbeted fittings of the drive unit to the adapter and the adapter to the bearing frame automatically align the shaft to within the specified limits.

Specified limits

A C-face adapter can attain a nominal alignment of 0.18mm | 0.007 in. Total Indicated Runout (T.I.R.). However, because of the stack-up of the machining tolerances of the various parts, the alignment can be as high as 0.38mm | 0.015 inches TIR.

If high reliability (with shaft alignments of less than 0.05mm | 0.002 in.) is required for the pump, use a foot-mounted drive unit on a precision-machined baseplate and perform a conventional alignment.

4.5 Grout the baseplate

Required equipment:

- Cleaners: Do not use an oil-based cleaner because the grout will not bond to it. See the instructions provided by the grout manufacturer.
 - Grout: Non-shrink grout is recommended.
1. Clean all the areas of the baseplate that will come into contact with the grout.
 2. Build a dam around the foundation.
 3. Thoroughly wet the foundation that will come into contact with the grout.
 4. Pour grout through the grout hole into the baseplate up to the level of the dam.
When you pour the grout, remove air bubbles from it by using one of these methods:
 - Puddle with a vibrator.
 - Pump the grout into place.
 5. Allow the grout to set.

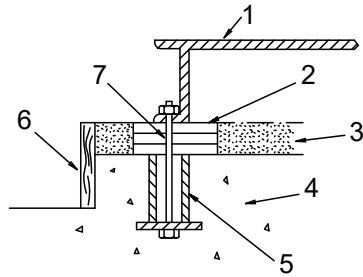

Item	Description
1.	Baseplate
2.	Shims or wedges
3.	Grout
4.	Foundation
5.	Sleeve
6.	Dam
7.	Bolt

Figure 32: Pour grout into baseplate

- Fill the remainder of the baseplate with grout, and allow the grout to set for at least 48 hours.

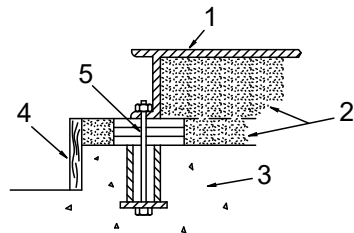

Item	Description
1.	Baseplate
2.	Grout
3.	Foundation
4.	Dam
5.	Bolt

Figure 33: Fill remainder of baseplate with grout

- Tighten the foundation bolts.

4.6 Piping checklists

4.6.1 General piping checklist

Precautions



WARNING:

- Risk of premature failure. Casing deformation can result in misalignment and contact with rotating parts, causing excess heat generation and sparks. Flange loads from the piping

system, including those from the thermal expansion of the piping, must not exceed the limits of the pump.

- Risk of serious personal injury or property damage. Fasteners such as bolts and nuts are critical to the safe and reliable operation of the product. Ensure appropriate use of fasteners during installation or reassembly of the unit.
 - Use fasteners of the proper size and material only.
 - Replace all corroded fasteners.
 - Ensure that all fasteners are properly tightened and that there are no missing fasteners.

NOTICE:

Vary the capacity with the regulating valve in the discharge line. Never throttle the flow from the suction side. This action can result in decreased performance, unexpected heat generation, and equipment damage.

Piping guidelines

Guidelines for piping are given in the Hydraulic Institute Standards available from the Hydraulic Institute at 9 Sylvan Way, Parsippany, NJ 07054-3802. You must review this document before you install the pump.

Checklist

Check	Explanation/comment	Checked
Check that all piping is supported independently of, and lined up naturally with, the pump flange.	<ul style="list-style-type: none"> • Strain on the pump • Misalignment between the pump and the drive unit • Wear on the pump bearings and the coupling 	
Keep the piping as short as possible.	This helps to minimize friction losses.	
Keep the piping as straight as possible. Avoid unnecessary bends. Use 45° or long radius 90° fittings where necessary.	This helps to minimize friction losses.	
Check that only necessary fittings are used.	This helps to minimize friction losses.	
Make sure that the inside diameters match properly when you use flange joints.	—	
Do not connect the piping to the pump until: <ul style="list-style-type: none"> • The grout for the baseplate or sub-base becomes hard. • The grout for the pit cover becomes hard. • The hold-down bolts for the pump and the driver are tightened. 	—	
Make sure that all the piping joints and fittings are airtight.		
If the pump handles corrosive fluids, make sure that the piping allows you to flush out the liquid before you remove the pump.		

Check	Explanation/comment	Checked
If the pump handles liquids at elevated temperatures, make sure that the expansion loops and joints are properly installed.	This helps to prevent misalignment due to linear expansion of the piping.	
Make sure that all piping components, valves and fittings, and pump branches are clean prior to assembly.	—	
Make sure that the isolation and check valves are installed in the discharge line.	Locate the check valve between the isolation valve and the pump. This will permit inspection of the check valve. The isolation valve is required for regulation of flow, and for inspection and maintenance of the pump. The check valve prevents pump or seal damage due to reverse flow through the pump when the driver is turned off.	
Use cushioning devices.	This protects the pump from surges and water hammer if quick-closing valves are installed in the system.	
In no case should loads on the pump flanges exceed the limits stated in API Standard 610, 11th Edition (ISO 13709).	Bottom of casing should be supported by a solid foundation or casing feet should be used.	

Example: Installation for expansion

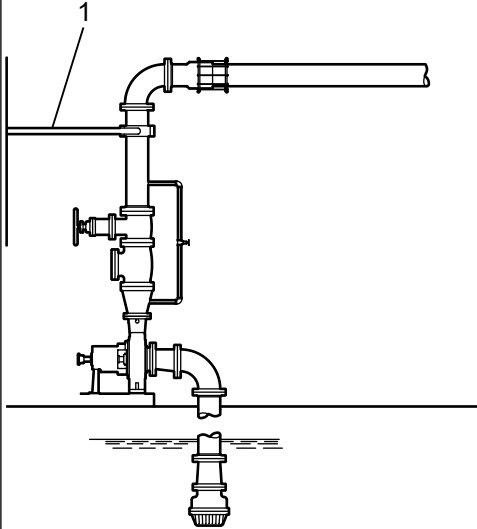
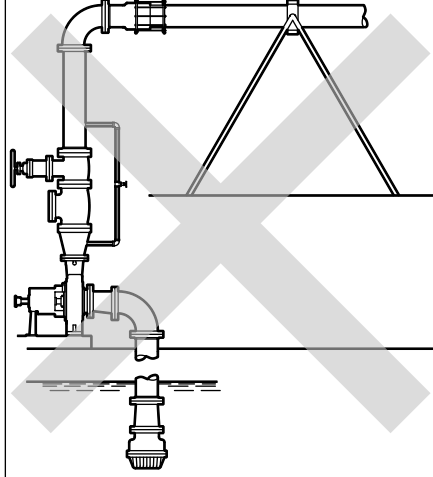
Correct	Incorrect
<p>This illustration shows a correct installation for expansion:</p>  <p>1. Expansion loop/joint</p>	<p>This illustration shows an incorrect installation for expansion:</p> 

4.6.1.1 Fastening



WARNING:

Risk of serious personal injury or property damage. Fasteners such as bolts and nuts are critical to the safe and reliable operation of the product. Ensure appropriate use of fasteners during installation or reassembly of the unit.

- Use fasteners of the proper size and material only.
- Replace all corroded fasteners.

- Ensure that all fasteners are properly tightened and that there are no missing fasteners.

4.6.2 Suction-piping checklist

Performance curve reference

Net positive suction head available (NPSH_A) must always exceed NPSH required (NPSH_R) as shown on the published performance curve of the pump.

Suction-piping checks

Check	Explanation/comment	Checked
Check that the distance between the inlet flange of the pump and the closest elbow is at least five pipe diameters.	This minimizes the risk of cavitation in the suction inlet of the pump due to turbulence. See the Example sections for illustrations.	
Check that elbows in general do not have sharp bends.	See the Example sections for illustrations. —	
Check that the suction piping is one or two sizes larger than the suction inlet of the pump. Install an eccentric reducer between the pump inlet and the suction piping.	The suction piping must never have a smaller diameter than the suction inlet of the pump. See the Example sections for illustrations.	
Check that the eccentric reducer at the suction flange of the pump has the following properties: <ul style="list-style-type: none"> • Sloping side down • Horizontal side at the top 	See the example illustrations.	
Suggested suction strainers are used. Check that they are at least three times the area of the suction piping. Monitor the pressure drop across the suction strainer. An increased pressure drop across the strainer of 34.5 kPa 5 psi indicates that the strainer should be removed and cleaned. After a period of time (24 hours minimum) system flushing should be complete and the suction strainer can be removed.	Suction strainers help to prevent debris from entering the pump. Mesh holes with a minimum diameter of 1.6 mm 1/16 in. are recommended. Liquids with specific gravity less than 0.60 a pressure drop across the suction strainer may be due to ice buildup. Ice buildup can cause turbulence, low pressure areas and pumpage vaporization.	
If more than one pump operates from the same liquid source, check that separate suction-piping lines are used for each pump.	This recommendation helps you to achieve a higher pump performance and prevent vapor locking especially with specific gravity of liquid less than 0.60.	
If necessary, make sure that the suction piping includes a drain valve and that it is correctly installed.	—	
Assure adequate insulation is applied for liquids with specific gravity less than 0.60.	To assure sufficient NPSH _A .	

Liquid source below the pump

Check	Explanation/comment	Checked
Make sure that the suction piping is free from air pockets.	This helps to prevent the occurrence of air and cavitation in the pump inlet.	
Check that the suction piping slopes upwards from the liquid source to the pump inlet.	—	
If the pump is not self-priming, check that a device for priming the pump is installed.	Use a foot valve with a diameter that is at least equivalent to the diameter of the suction piping.	

Liquid source above the pump

Check	Explanation/comment	Checked
Check that an isolation valve is installed in the suction piping at a distance of at least two times the pipe diameter from the suction inlet.	This permits you to close the line during pump inspection and maintenance. Do not use the isolation valve to throttle the pump. Throttling can cause these problems: <ul style="list-style-type: none"> • Loss of priming • Excessive temperatures • Damage to the pump • Voiding the warranty 	
Make sure that the suction piping is free from air pockets.	This helps to prevent the occurrence of air and cavitation in the pump inlet.	
Check that the piping is level or slopes downward from the liquid source.	—	
Make sure that no part of the suction piping extends below the suction flange of the pump.	—	
Make sure that the suction piping is adequately submerged below the surface of the liquid source.	This prevents air from entering the pump through a suction vortex.	

Example: Elbow close to the pump suction inlet

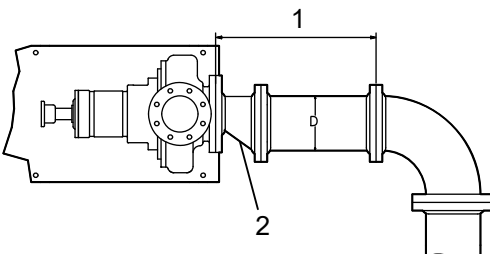
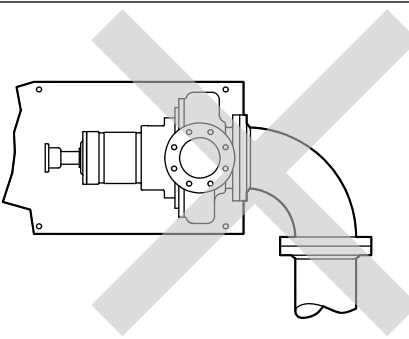
Correct	Incorrect
<p>The correct distance between the inlet flange of the pump and the closest elbow must be at least five pipe diameters.</p>  <ol style="list-style-type: none"> 1. Enough distance to prevent cavitation 2. Eccentric reducer with a level top 	

Example: Suction piping equipment

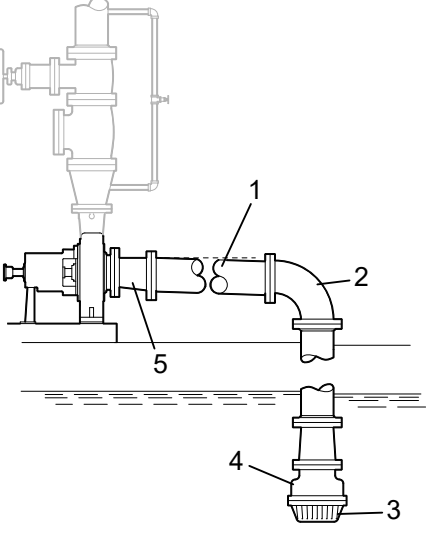
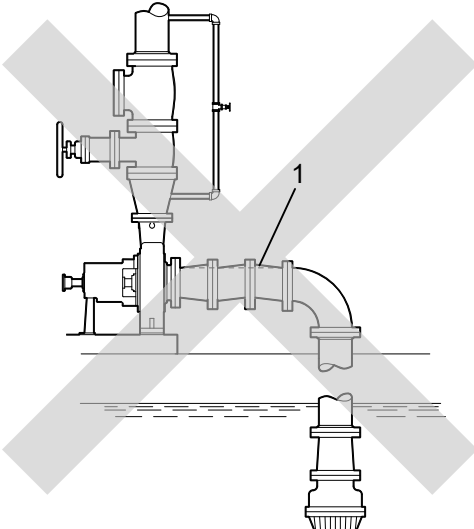
Correct	Incorrect
 <ol style="list-style-type: none"> 1. Suction pipe sloping upwards from liquid source 2. Long-radius elbow 3. Strainer 4. Foot valve 5. Eccentric reducer with a level top 	 <ol style="list-style-type: none"> 1. Air pocket, because the eccentric reducer is not used and because the suction piping does not slope gradually upward from the liquid source

4.6.3 Discharge piping checklist

Checklist

Check	Explanation/comment	Checked
<p>Check that an isolation valve is installed in the discharge line. For specific gravity less than 0.60, minimize distance from pump discharge.</p>	<p>The isolation valve is required for:</p> <ul style="list-style-type: none"> • Priming • Regulation of flow • Inspection and maintenance of the pump • Reduce risk of pumpage vaporization and vapor locking at low flow rates for low specific gravity liquids. <p>See Example: Discharge piping equipment for illustrations.</p>	
<p>Check that a check valve is installed in the discharge line, between the isolation valve and the pump discharge outlet.</p>	<p>The location between the isolation valve and the pump allows inspection of the check valve.</p> <p>The check valve prevents damage to the pump and seal due to the back flow through the pump, when the drive unit is shut off. It is also used to restrain the liquid flow.</p> <p>See Example: Discharge piping equipment for illustrations.</p>	
<p>If increasers are used, check that they are installed between the pump and the check valve.</p>	<p>See Example: Discharge piping equipment for illustrations.</p>	

Check	Explanation/comment	Checked
If quick-closing valves are installed in the system, check that cushioning devices are used.	This protects the pump from surges and water hammer.	

Example: Discharge piping equipment

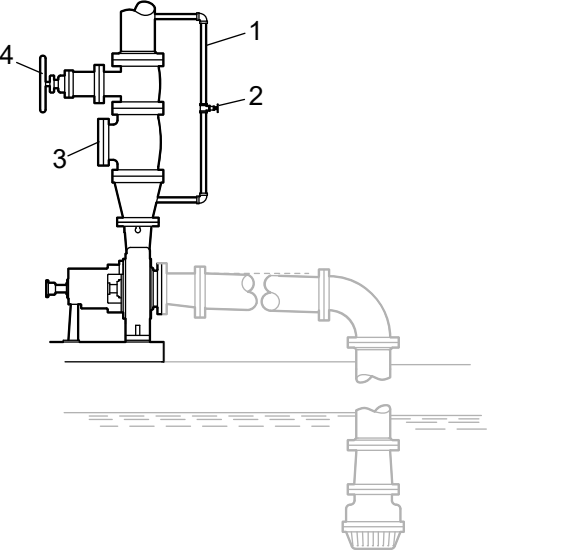
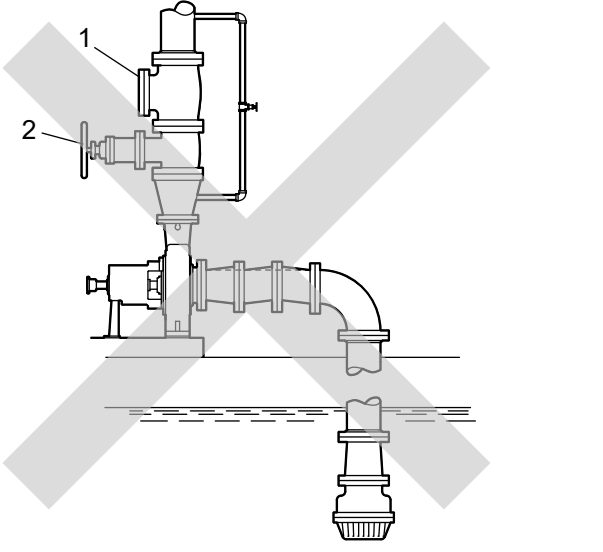
Correct	Incorrect
 <ol style="list-style-type: none"> 1. Bypass line 2. Shut-off valve 3. Check valve 4. Discharge isolation valve 	 <ol style="list-style-type: none"> 1. Check valve (incorrect position) 2. The isolation valve should not be positioned between the check valve and the pump.

5 Commissioning, Startup, Operation, and Shutdown

5.1 Preparation for startup



WARNING:

- Risk of serious physical injury or death. Exceeding any of the pump operating limits (e.g. - pressure, temperature, power, etc.) could result in equipment failure, such as explosion, seizure, or breach of containment. Assure that the system operating conditions are within the capabilities of the pump.
 - Risk of death or serious injury. Leaking fluid can cause fire and/or burns. Ensure all openings are sealed prior to filling the pump.
 - Breach of containment can cause fire, burns, and other serious injury. Failure to follow these precautions before starting the unit may lead to dangerous operating conditions, equipment failure, and breach of containment.
 - Risk of explosion and serious physical injury. Do not operate pump with blocked system piping or with suction or discharge valves closed. This can result in rapid heating and vaporization of pumpage.
 - Risk of breach of containment and equipment damage. Ensure the pump operates only between minimum and maximum rated flows. Operation outside of these limits can cause high vibration, mechanical seal and/or shaft failure, and/or loss of prime.
-



WARNING:

- Risk of death, serious personal injury, and property damage. Heat and pressure buildup can cause explosion, rupture, and discharge of pumpage. Never operate the pump with suction and/or discharge valves closed.
 - Running a pump without safety devices exposes operators to risk of serious personal injury or death. Never operate a unit unless appropriate safety devices (guards, etc.) are properly installed.
 - Failure to disconnect and lock out driver power may result in serious physical injury or death. Always disconnect and lock out power to the driver before performing any installation or maintenance tasks.
 - Electrical connections must be made by certified electricians in compliance with all international, national, state, and local rules.
 - Refer to driver/coupling/gear manufacturer's installation and operation manuals (IOM) for specific instructions and recommendations.
 - Starting the pump in reverse rotation can result in the contact of metal parts, heat generation, and breach of containment. Ensure correct driver settings prior to starting any pump.
-

Precautions



WARNING:

The mechanical seal used in an Ex-classified environment must be properly certified.

**CAUTION:**

When a cartridge mechanical seal is used, ensure that the set screws in the seal locking ring are tightened and that the centering clips have been removed prior to startup. This prevents seal or shaft sleeve damage by ensuring that the seal is properly installed and centered on the sleeve.

NOTICE:

- Verify the driver settings before you start any pump. Refer to the applicable drive equipment IOMs and operating procedures.
- Excessive warm-up rates can cause equipment damage. Ensure the warm-up rate does not exceed 1.4°C | 2.5°F per minute.

NOTICE:

You must follow these precautions before you start the pump:

- Flush and clean the system thoroughly to remove dirt or debris in the pipe system in order to prevent premature failure at initial startup.
- Bring variable-speed drivers to the rated speed as quickly as possible.
- Run a new or rebuilt pump at a speed that provides enough flow to flush and cool the close-running surfaces of the stuffing-box bushing.
- If temperatures of the pumped fluid will exceed 93°C | 200°F, then warm up the pump prior to operation. Circulate a small amount of fluid through the pump until the casing temperature is within 38°C | 100°F of the fluid temperature. Accomplish this by flowing fluid from pump inlet to discharge drain (optionally, the casing vent can be included in warm-up circuit but not required). Soak for (2) hours at process fluid temperature.

At initial startup, do not adjust the variable-speed drivers or check for speed governor or over-speed trip settings while the variable-speed driver is coupled to the pump. If the settings have not been verified, then uncouple the unit and refer to instructions supplied by the driver manufacturer.

5.2 Remove the coupling guard

1. Remove the nut, bolt, and washers from the slotted hole in the center of the coupling guard.
2. Slide the driver half of the coupling guard toward the pump.

5.2 Remove the coupling guard

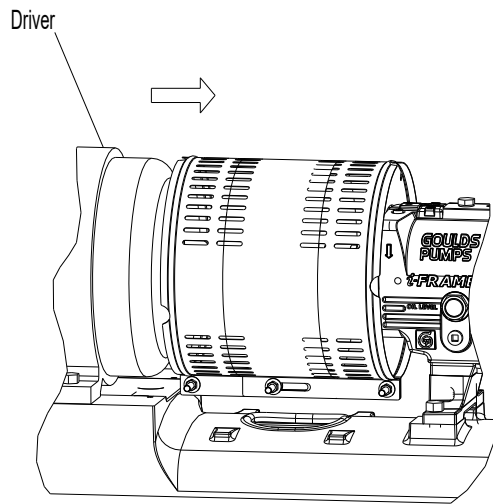

3. Remove the nut, bolt, and washers from the driver half of the coupling guard.
4. Remove the driver half of the coupling guard:
 - a) Slightly spread the bottom apart.
 - b) Lift upwards.

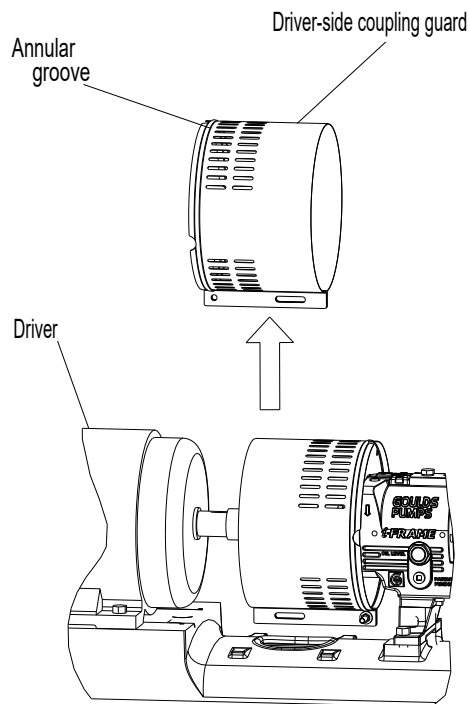

5. Remove the remaining nut, bolt, and washers from the pump half of the coupling guard. It is not necessary to remove the end plate from the pump side of the bearing housing. You can access the bearing-housing tap bolts without removing this end plate if maintenance of internal pump parts is necessary.
6. Remove the pump half of the coupling guard:
 - a) Slightly spread the bottom apart.
 - b) Lift upwards.

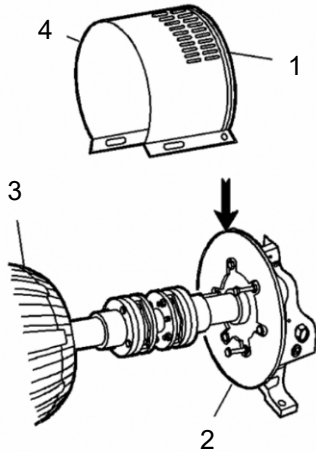

Item	Description
1.	Annular groove
2.	Pump-side end plate
3.	Driver
4.	Pump half of the coupling guard

5.3 Check the rotation



WARNING:

- Starting the pump in reverse rotation can result in the contact of metal parts, heat generation, and breach of containment. Ensure correct driver settings prior to starting any pump.
- Failure to disconnect and lock out driver power may result in serious physical injury or death. Always disconnect and lock out power to the driver before performing any installation or maintenance tasks.
 - Electrical connections must be made by certified electricians in compliance with all international, national, state, and local rules.
 - Refer to driver/coupling/gear manufacturer's installation and operation manuals (IOM) for specific instructions and recommendations.

- Lock out power to the driver.
- Make sure that the coupling hubs are fastened securely to the shafts.
- Make sure that the coupling spacer is removed.
The pump ships with the coupling spacer removed.
- Unlock power to the driver.
- Make sure that everyone is clear, and then jog the driver long enough to determine that the direction of rotation corresponds to the arrow on the bearing housing or close-coupled frame.
- Lock out power to the driver.

5.4 Impeller-clearance check

The impeller-clearance check ensures the following:

- The pump turns freely.
- The pump operates at optimal efficiency for long equipment life and low energy consumption.

5.4.1 Impeller clearances (NM 3196)

NOTICE:

Set the cold (ambient) impeller clearance according to and . Failure to do so may result in heat generation and equipment damage. Higher clearances are used above 93°C | 200°F to prevent the impeller from contacting the casing due to thermal expansion.

Table 10: NM 3196 impeller clearances

The NM 3196 requires the impeller clearances in the following table.

Service temperature	STX	MTX/LTX
	STi	MTi/LTi
	mm in.	mm in.
-29 to 93°C -20 to 200°F	0.13 0.005	0.20 0.008

5.5 Impeller-clearance setting

Importance of a proper impeller clearance

A proper impeller clearance ensures that the pump runs at high performance.



WARNING:

The impeller clearance setting procedure must be followed. Improperly setting the clearance or not following any of the proper procedures can result in sparks, unexpected heat generation, and equipment damage.



WARNING:

- Risk of mechanical seal damage leading to breach of containment. If a cartridge mechanical seal is used, ensure that the set screws in the seal locking ring are loosened and that the centering clips have been installed prior to clearance adjustment.

Impeller clearance methods

You can set the impeller clearance with either of these methods:

- Dial indicator method
- Feeler gauge method

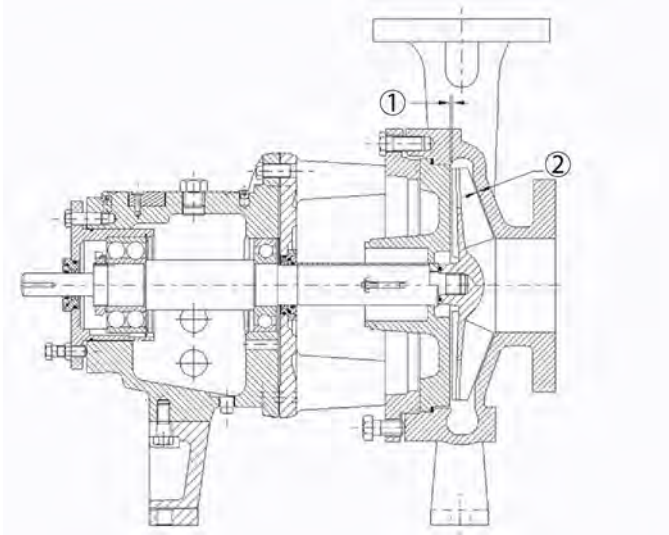

1. Back clearance
2. Front clearance

Figure 34: Impeller clearance measurement

5.5.1 Set the impeller clearance - dial indicator method (all except CV 3196, CV 3198, and LF 3196 size 1x1.5-4)



WARNING:

Failure to disconnect and lock out driver power may result in serious physical injury or death. Always disconnect and lock out power to the driver before performing any installation or maintenance tasks.

- Electrical connections must be made by certified electricians in compliance with all international, national, state, and local rules.
- Refer to driver/coupling/gear manufacturer's installation and operation manuals (IOM) for specific instructions and recommendations.

1. Remove the coupling guard.
2. Set the indicator so that the button contacts either the shaft end or the face of the coupling.

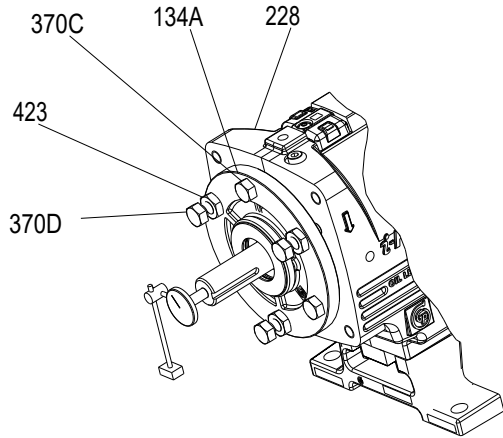

Figure 35: Dial indicator setting

3. Loosen the jam nuts (423) on the jack bolts (370D) , and then back the bolts out about two turns.
4. Tighten the locking bolts evenly (370C), bringing the bearing housing (134A) towards the frame (228) until the impeller contacts the casing.
5. Turn the shaft to ensure that there is contact between the impeller and the casing.
6. Set the indicator to zero and loosen the locking bolt (370C) about one turn.
7. Thread in the jack bolts (370D) until the jack bolts evenly contact the bearing frame.
8. Tighten the jack bolts evenly about one flat at a time, moving the bearing housing (134A) away from the bearing frame until the indicator shows the correct clearance.
Refer to the impeller clearance table to determine the correct clearance.
9. Tighten the bolts evenly in this order:
 - a) Tighten the locking bolts (370C).
 - b) Tighten the jack bolts (370D).Make sure to keep the indicator reading at the proper setting.
10. Make sure the shaft turns freely.

5.5.2 Set the impeller clearance - feeler gauge method (all except CV 3196, CV3198 and LF 3196 size 1x1.5-4)



WARNING:

Failure to disconnect and lock out driver power may result in serious physical injury or death. Always disconnect and lock out power to the driver before performing any installation or maintenance tasks.

- Electrical connections must be made by certified electricians in compliance with all international, national, state, and local rules.
 - Refer to driver/coupling/gear manufacturer's installation and operation manuals (IOM) for specific instructions and recommendations.
-

1. Lock out the driver power and remove the coupling guard.
2. Loosen the jam nuts (423B) on the jack bolts (371A), and then back the bolts out about two turns.

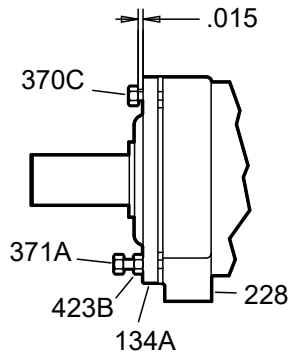

Figure 36: Impeller clearance setting

3. Evenly tighten the locking bolts (370C), bringing the bearing housing (134A) towards the frame (228) until the impeller contacts the casing.
4. Turn the shaft to ensure that there is contact between the impeller and the casing.
5. Use a feeler gauge to set the gap between the three locking bolts (370C) and the bearing housing (134A) to the correct impeller clearance.
Refer to the impeller clearance table to determine the correct clearance.
6. Use the three jack bolts (370D) to evenly loosen the bearing housing (134A) until it contacts the locking bolts (370C).
7. Evenly tighten the jam nuts (423B).
8. Set the indicator to zero and turn back the locking bolt (370C) one turn.
9. Thread the adjuster bolts (371A) in until they evenly contact the bearing frame.
10. Tighten the adjuster bolts evenly (about one flat at a time) and back the bearing housing (134A) away from the bearing frame until the indicator shows the proper clearance per the Cold temperature axial clearance (open and closed impeller) table.
11. Evenly tighten the locking bolts (370C) and then the adjuster bolts (371A) while keeping the indicator reading at the proper setting.
12. Make sure the shaft turns freely.

5.6 Couple the pump and driver



WARNING:

Failure to disconnect and lock out driver power may result in serious physical injury or death. Always disconnect and lock out power to the driver before performing any installation or maintenance tasks.

- Electrical connections must be made by certified electricians in compliance with all international, national, state, and local rules.
- Refer to driver/coupling/gear manufacturer's installation and operation manuals (IOM) for specific instructions and recommendations.



Couplings must have proper certification to be used in an Ex classified environment. Use the instructions from the coupling manufacturer in order to lubricate and install the coupling. Refer to driver/coupling/gear manufacturers IOM for specific instructions and recommendations.

5.6.1 Install the coupling guard



WARNING:

- Running a pump without safety devices exposes operators to risk of serious personal injury or death. Never operate a unit unless appropriate safety devices (guards, etc.) are properly installed.
 - Failure to disconnect and lock out driver power may result in serious physical injury or death. Always disconnect and lock out power to the driver before performing any installation or maintenance tasks.
 - Electrical connections must be made by certified electricians in compliance with all international, national, state, and local rules.
 - Refer to driver/coupling/gear manufacturer's installation and operation manuals (IOM) for specific instructions and recommendations.
-



WARNING:

The coupling guard used in an Ex classified environment must be properly certified and constructed from a spark resistant material.

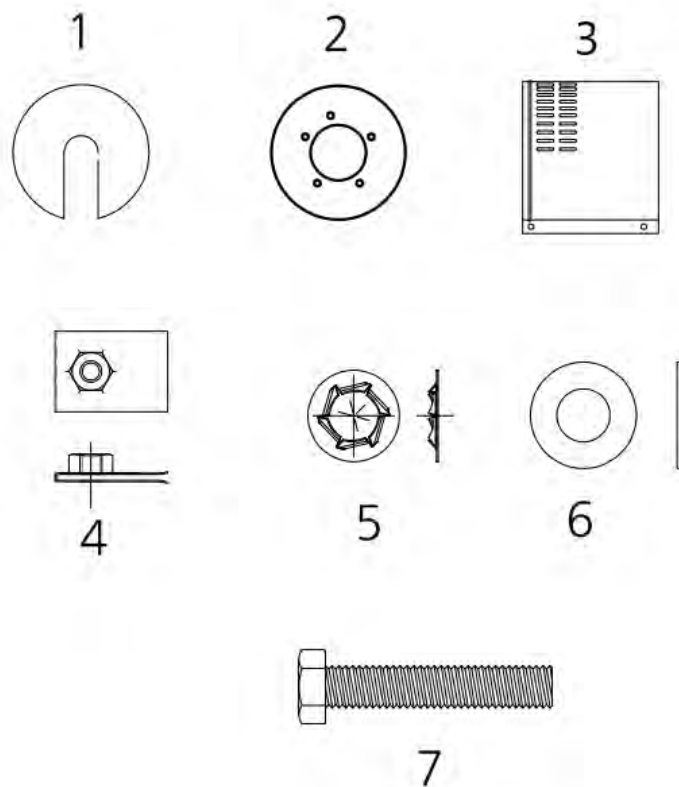

Part No.	Description	Part No.	Description
1	Cover driver	5	Retainer (Qty 3)
2	Cover pump	6	Washer (Qty 4)
3	Guard (Qty 2)	7	Hex head bolt (Qty 3)
4	U-nut (Qty 3)		

Figure 37: Required parts

- De-energize the motor, place the motor in a locked-out position, and place a caution tag at the starter that indicates the disconnect.
- Put the pump-side end plate in place.
If the pump-side end plate is already in place, make any necessary coupling adjustments and then proceed to the next step.

If the pump size is...	Then...
STi, MTi	Align the pump-side end plate to the bearing frame. You do not need to adjust the impeller.

- Slightly spread the opening of the coupling guard half and place it over the pump end plate.
 - The annular groove in the guard is located around the end plate.
 - Position the opening (flange) so that it does not interfere with the piping but still allows for access when you install the bolts.

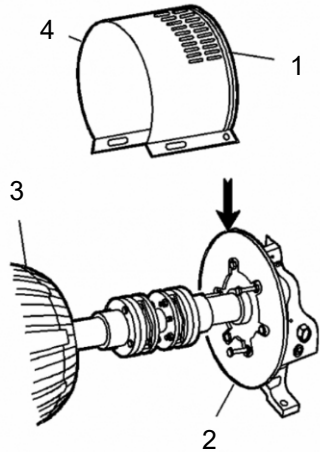

Item	Description
1.	Annular groove
2.	Pump-side end plate
3.	Driver
4.	Pump half of the coupling guard

Figure 38: Align pump end guard half with annular groove

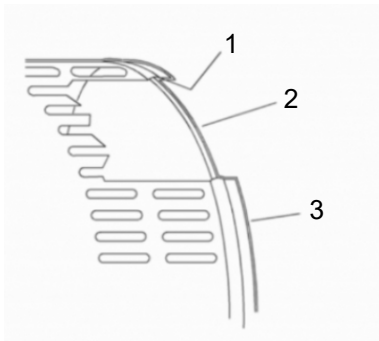

Item	Description
1.	Annular groove
2.	End plate (pump end)
2.	Guard half

Figure 39: Annular groove in coupling guard

4. Place one washer over the bolt and insert the bolt through the round hole at the front end of the guard half.

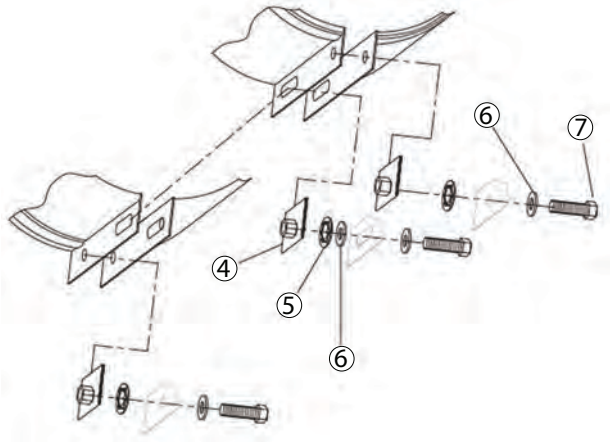

Figure 40: Captured hardware component assembly

5. Install the bolt retainer over the exposed end of the bolt, and the U-Nut into the slot in the coupling guard if it was not done from the factory.
6. Thread bolt into the U-Nut and tighten firmly.
7. Slightly spread the opening of the remaining coupling guard half and place it over the installed coupling guard half so that the annular groove in the remaining coupling guard half faces the motor.

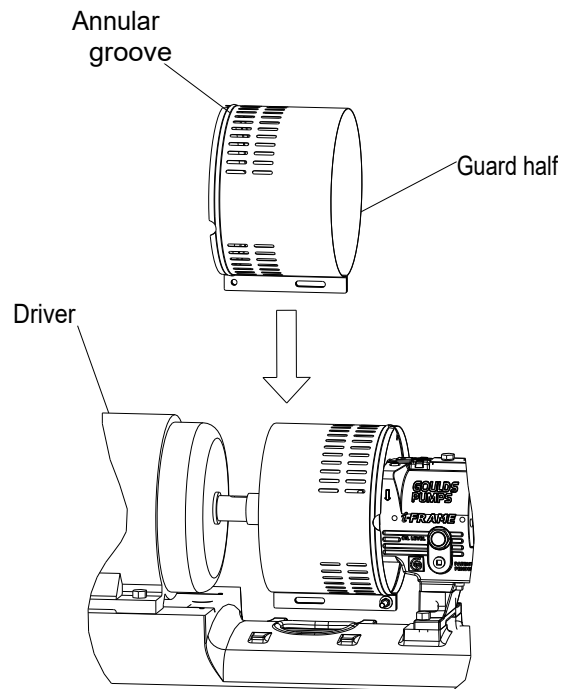

Figure 41: Placement of driver half of coupling guard

8. Place the end plate over the driver shaft and locate the end plate in the annular groove at the rear of the coupling guard half.

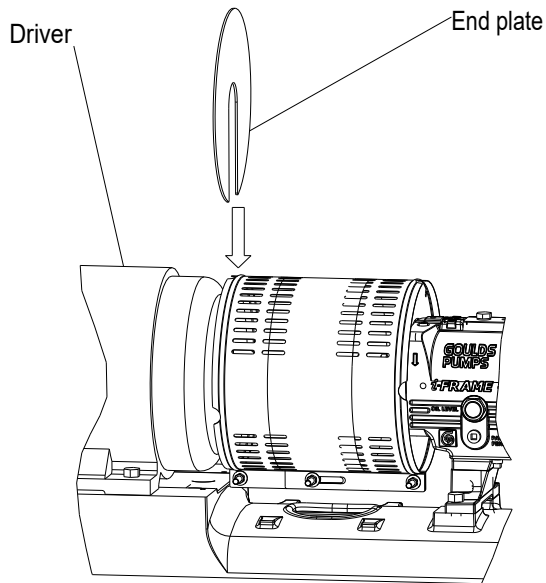

Figure 42: Placement of driver half of coupling guard

9. Hand-tighten only. Repeat Steps 4 through 6 for the rear end of the coupling guard half. The hole is located on the driver-side of the coupling guard half.
10. Slide the driver-half of the coupling guard towards the motor so that the coupling guard completely covers the shafts and coupling.

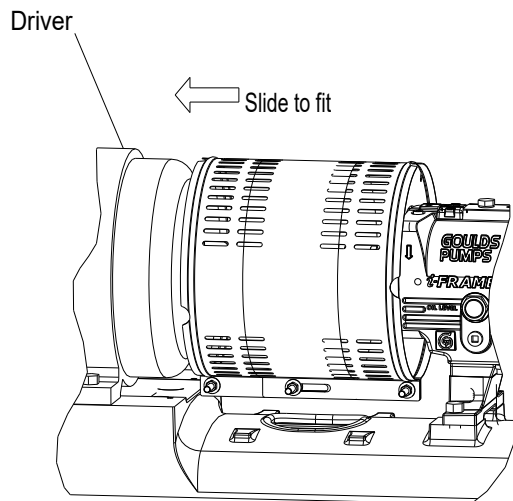

Figure 43: Slide driver-half of coupling guard towards motor

11. Repeat Steps 4 through 6 for the center slots in the coupling guard.
12. Tighten all nuts on the guard assembly.

5.6.2 Bearing lubrication



WARNING:

Risk of explosive hazard and premature failure from sparks and heat generation. Ensure bearings are properly lubricated prior to startup.

NOTICE:

Grease can settle in equipment left idle leaving bearings improperly lubricated. Check the greasing on a pump that has been out of service for a long period of time and re-grease if necessary.

Pumps are shipped without oil. You must lubricate oil-lubricated bearings at the job site.

Grease-lubricated bearings are lubricated at the factory.

The bearing manufacturer fills greased-for-life bearings with grease and seals them at the factory. You do not need to lubricate or seal these bearings.

5.6.2.1 Oil volumes

Oil volume requirements

This table shows the required amount of oil for oil-lubricated bearings.

Frame	ml	Qts.	Oz.
STi	400	0.5	16
MTi	1400	1.5	47

5.6.2.2 Lubricating-oil requirements

Oil requirements based on temperature

For the majority of operating conditions, bearing temperatures run between 49°C | 120°F and 82°C | 180°F, and you can use an oil of ISO viscosity grade 68 at 38°C | 100°F. If temperatures exceed 82°C | 180°F, refer to the table for temperature requirements.

Temperature	Oil requirement
Bearing temperatures exceed 82°C 180°F	Use ISO viscosity grade 100 with bearing-frame cooling or finned-tube oil cooler. The finned-tube oil cooler is standard with the HT 3196 model and optional for all other models.
Pumped-fluid temperatures exceed 177°C 350°F	Use synthetic lubrication.

5.6.2.3 Acceptable oil for lubricating bearings

Acceptable lubricants

Table 11: Acceptable lubricants

Brand	Lubricant type
Chevron	GST Oil 68
Exxon	Teresstic EP 68
Mobil	DTE Heavy Medium
Phillips 66	Turbine Oil VG68

Brand	Lubricant type
Shell	Turbo T 68
Sunoco	Sunvis 968
Royal Purple	SYNFILM ISO VG 68 Synthetic Oil

5.6.2.4 Lubricate the bearings with oil



WARNING:

Risk of explosive hazard and premature failure from sparks and heat generation. Ensure bearings are properly lubricated prior to startup.

Use a high-quality turbine oil with rust and oxidation inhibitors.

1. Remove the fill plug.
2. Fill the bearing frame with oil through the filler connection, which is located on top of the bearing frame.

Fill the bearing frame with oil until the oil level reaches the middle of the sight glass (319). The correct volume of oil required for each size of bearing frame can be found in the 'Oil Volume Requirements' section in the 'Bearing Maintenance' / 'Maintenance' portion of the IOM.

Oil lubricated bearings

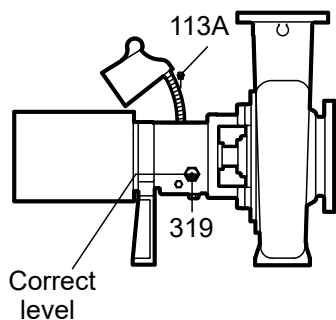

Figure 44: Oil filler connection

3. Replace the fill plug.

5.6.2.5 Lubricate the bearings with pure oil mist

Oil mist is an optional feature for this pump.

- To lubricate bearings with pure oil mist, follow the instructions provided by the manufacturer of the oil-mist generator.

The inlet connections are on the top of the bearing frame.

5.6.2.6 Greased-for-life bearing lubrication

The bearing manufacturer fills greased-for-life bearings with grease and seals them at the factory. You do not need to lubricate or seal these bearings. Refer to the Maintenance chapter for re-greasing and maintenance procedures for these bearings.

5.7 Shaft-sealing options

In most cases, the manufacturer seals the shaft before shipping the pump. If your pump does not have a sealed shaft, see the Shaft-seal maintenance section in the Maintenance chapter.

This model uses these types of shaft seals:

- Cartridge mechanical seal
- Conventional inside-component mechanical seal
- Conventional outside-component mechanical seal

5.7.1 Mechanical seal options

Pumps are usually shipped with mechanical seals installed. If they are not, then refer to the mechanical seal manufacturer's installation instructions.

These are the mechanical seal options for this pump:

- Cartridge mechanical seal
- Conventional inside component mechanical seal
- Conventional outside component mechanical seal

5.7.2 Connection of sealing liquid for mechanical seals

Seal lubrication is required

Seal faces must have liquid film between them for proper lubrication. Locate the taps using the illustrations shipped with the seal.

Seal flushing methods

Table 12: You can use these methods in order to flush or cool the seal:

Method	Description
Product flush	Run the piping so that the pump pushes the pumped fluid from the casing and injects it into the seal gland. If necessary, an external heat exchanger cools the pumped fluid before it enters the seal gland.
External flush	Run the piping so that the pump injects a clean, cool, compatible liquid directly into the seal gland. The pressure of the flushing liquid must be 0.35 to 1.01 kg/cm ² 5 to 15 psi greater than the seal chamber pressure. The injection rate must be 2 to 8 lpm 0.5 to 2 gpm.
Other	You can use other methods that employ multiple gland or seal chamber connections. Refer to the mechanical seal reference drawing and piping diagrams.

5.8 Install the shaft guard - if provided



WARNING:

- Running a pump without safety devices exposes operators to risk of serious personal injury or death. Never operate a unit unless appropriate safety devices (guards, etc.) are properly installed.
- Failure to disconnect and lock out driver power may result in serious physical injury or death. Always disconnect and lock out power to the driver before performing any installation or maintenance tasks.
 - Electrical connections must be made by certified electricians in compliance with all international, national, state, and local rules.
 - Refer to driver/coupling/gear manufacturer's installation and operation manuals (IOM) for specific instructions and recommendations.

Exposed rotating shaft between pump seal and bearing frame. Avoid contact and/or install proper guarding. If guarding is not provided with the pump, contact Goulds for price and availability of proper guarding.

5.9 Pump priming

5.9.1 Prime the pump with the suction supply above the pump

1. Slowly open the suction isolation valve.
2. Open the air vents on the suction and discharge piping until the pumped fluid flows out.
3. Close the air vents.

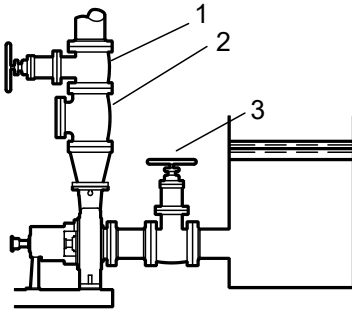

Item	Description
1.	Discharge isolation valve
2.	Check valve
3.	Suction isolation valve

Figure 45: Suction supply above pump

5.9.2 Prime the pump with the suction supply below the pump

Use a foot valve and an outside source of liquid in order to prime the pump. The liquid can come from one of these sources:

- A priming pump
 - A pressurized discharge line
 - Another outside supply
1. Close the discharge isolation valve.
 2. Open the air vent valves in the casing.
 3. Open the valve in the outside supply line until only liquid escapes from the vent valves.
 4. Close the vent valves.
 5. Close the outside supply line.

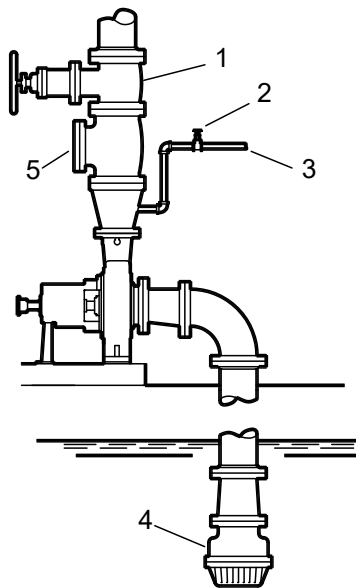

Item	Description
1.	Discharge isolation valve
2.	Shutoff valve
3.	From outside supply
4.	Foot valve
5.	Check valve

Figure 46: Pump priming with suction supply below pump with foot valve and an outside supply

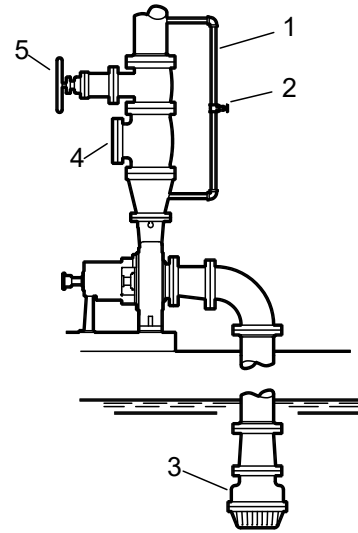

Item	Description
1.	By-pass line
2.	Shutoff valve
3.	Foot valve
4.	Check valve
5.	Discharge isolation valve

Figure 47: Pump priming with suction supply below pump with foot valve using bypass around check valve

5.9.3 Other methods of priming the pump

You can also use these methods in order to prime the pump:

- Prime by ejector
- Prime by automatic priming pump

5.10 Start the pump



WARNING:

- Risk of equipment damage, seal failure and breach of containment. Ensure all flush and cooling systems are operating correctly prior to starting pump.
-

NOTICE:

- Risk of equipment damage due to dry operation. Immediately observe the pressure gauges. If discharge pressure is not quickly attained, stop the driver immediately, reprime, and attempt to restart the pump.

- To avoid risk of equipment damage, observe the pump for vibration levels, bearing temperature, and excessive noise. If normal levels are exceeded, shut down the pump and resolve the issue.
-
-

NOTICE:

Risk of equipment damage on pure or purge-oil mist-lubricated units. Remove the viewing port plugs to verify that oil mist is flowing properly. Reinstall the plugs after confirming.

Before you start the pump, you must perform these tasks:

- Open the suction valve.
 - Open any recirculation or cooling lines.
1. Fully close or partially open the discharge valve, depending on system conditions.
 2. Start the driver.
 3. Slowly open the discharge valve until the pump reaches the desired flow.
 4. Immediately check the pressure gauge to ensure that the pump quickly reaches the correct discharge pressure.
 5. If the pump fails to reach the correct pressure, perform these steps:
 - a) Stop the driver.
 - b) Prime the pump again.
 - c) Restart the driver.
 6. Monitor the pump while it is operating:
 - a) Check the pump for bearing temperature, excessive vibration, and noise.
 - b) If the pump exceeds normal levels, then shut down the pump immediately and correct the problem.

A pump can exceed normal levels for several reasons. See Troubleshooting for information about possible solutions to this problem.
 7. Repeat steps 5 and 6 until the pump runs properly.

5.11 i-ALERT® Equipment Health Monitor



WARNING:

Explosive hazard and risk of personal injury. Heating to high temperatures could cause combustion of the condition monitor. Never heat the condition monitor to temperatures in excess of 149°C | 300°F or dispose of in a fire.

For all information refer to the i-ALERT® Equipment Health Monitor Installation, Operation and Maintenance manual. <https://www.i-alert.com/support/>

5.12 Pump operation precautions

General considerations



WARNING:

- Risk of serious personal injury or property damage. Dry running may cause rotating parts within the pump to seize to non-moving parts. Do not run dry.

- Risk of explosion and serious physical injury. Do not operate pump with blocked system piping or with suction or discharge valves closed. This can result in rapid heating and vaporization of pumpage.

NOTICE:

- Vary the capacity with the regulating valve in the discharge line. Never throttle the flow from the suction side. This action can result in decreased performance, unexpected heat generation, and equipment damage.
 - Risk of equipment damage from unexpected heat generation. Do not overload the driver. Ensure that the pump operating conditions are suitable for the driver. The driver can overload in these circumstances:
 - The specific gravity or viscosity of the fluid is greater than expected
 - The pumped fluid exceeds the rated flow rate.
-

Operation at reduced capacity

WARNING:

- Risk of breach of containment and equipment damage. Excessive vibration levels can cause damage to bearings, stuffing box, seal chamber, and/or mechanical seal. Observe pump for vibration levels, bearing temperature, and excessive noise. If normal levels are exceeded, shut down and resolve.
 - Risk of explosion and serious physical injury. Do not operate pump with blocked system piping or with suction or discharge valves closed. This can result in rapid heating and vaporization of pumpage.
 - Risk of equipment damage and serious physical injury. Heat build-up can cause rotating parts to score or seize. Observe pump for excessive heat build-up. If normal levels are exceeded, shut down and resolve.
-

NOTICE:

- Cavitation can cause damage to the internal surfaces of the pump. Ensure net positive suction head available (NPSH_A) always exceeds NPSH required (NPSH₃) as shown on the published performance curve of the pump.
 -
-

Operation under freezing conditions

NOTICE:

Do not expose an idle pump to freezing conditions. Drain all liquid that will freeze that is inside the pump and any auxiliary equipment. Failure to do so can cause liquid to freeze and damage the pump. Note that different liquids freeze at different temperatures. Some pump designs do not drain completely and may require flushing with a liquid that doesn't freeze.

5.13 Shut down the pump



WARNING:

Precautions must be taken to prevent physical injury. The pump may handle hazardous and/or toxic fluids. Proper personal protective equipment should be worn. Pumpage must be handled and disposed of in conformance with applicable environmental regulations.

1. Slowly close the discharge valve.
2. Shut down and lock out the driver to prevent accidental rotation.

5.14 Deactivate the i-ALERT® Equipment Health Monitor

NOTICE:

Always deactivate the health monitor when the pump is going to be shut down for an extended period of time. Failure to do so will result in reduced battery life.

Disengage the snap fit of the i-ALERT® using a flat head tool as shown below:



Figure 48: Disengage the battery from the sensor when shutting the pump for an extended period of time

5.15 Reset the i-ALERT® Health Monitor

To deactivate or reset the i-ALERT® monitor, please refer to the i-ALERT® IOM, <http://i-alert.com/>

Always reset the health monitor when the pump is started after maintenance, system change, or being shut down for an extended period of time. Failure to do so may result in false baseline levels that could cause the health monitor to alert in error.

5.16 Make the final alignment of the pump and driver



WARNING:

- Failure to disconnect and lock out driver power may result in serious physical injury or death. Always disconnect and lock out power to the driver before performing any installation or maintenance tasks.
 - Electrical connections must be made by certified electricians in compliance with all international, national, state, and local rules.

- Refer to driver/coupling/gear manufacturer's installation and operation manuals (IOM) for specific instructions and recommendations.
 - Misalignment can cause decreased performance, equipment damage, and even catastrophic failure of frame-mounted units leading to serious injury. Proper alignment is the responsibility of the installer and the user of the unit. Check the alignment of all drive components prior to operating the unit.
 - Follow the coupling installation and operation procedures from the coupling manufacturer.
-

You must check the final alignment after the pump and driver are at operating temperature. For initial alignment instructions, see the Installation chapter.

1. Run the unit under actual operating conditions for enough time to bring the pump, driver, and associated system to operating temperature.
2. Shut down the pump and the driver.
3. Remove the coupling guard.
See Remove the coupling guard in the Maintenance chapter.
4. Check the alignment while the unit is still hot.
5. Reinstall the coupling guard.
6. Restart the pump and driver.

6 Maintenance

6.1 Maintenance schedule

Maintenance inspections

A maintenance schedule includes these types of inspections:

- Routine maintenance
- Routine inspections
- Three-month inspections
- Annual inspections

Shorten the inspection intervals appropriately if the pumped fluid is abrasive or corrosive or if the environment is classified as potentially explosive.

Routine maintenance

Perform these tasks whenever you perform routine maintenance:



WARNING:

Move equipment to a safe/non Ex environment for repairs/adjustments or use spark resistant tools and work methods.

- Lubricate the bearings.
- Inspect the seal.

Routine inspections

Perform these tasks whenever you check the pump during routine inspections:



WARNING:

Move equipment to a safe/non Ex environment for repairs/adjustments or use spark resistant tools and work methods.

- Check the level and condition of the oil through the sight glass on the bearing frame.
 - Check for unusual noise vibration, and bearing temperatures.
 - Check the pump and piping for leaks.
 - Analyze the vibration.*
 - Inspect the discharge pressure.
 - Inspect the temperature.*
 - Check the seal chamber and stuffing box for leaks.
 - Ensure that there are no leaks from the mechanical seal.
 - Adjust or replace the packing in the stuffing box if you notice excessive leaking.
-

NOTICE:

*If equipped, temperature and vibration levels can be retrieved by using your i-ALERT® monitoring sensor and app.

Three-month inspections

Perform these tasks every three months:

- Check that the foundation and the hold-down bolts are tight.
- Check the packing if the pump has been left idle, and replace as required.
- Change the oil every three months (2000 operating hours) at minimum.
- Check the shaft alignment, and realign as required.

Annual inspections

Perform these inspections one time each year:

- Check the pump capacity.
- Check the pump pressure.
- Check the pump power.

If the pump performance does not satisfy your process requirements, and the process requirements have not changed, then perform these steps:

1. Disassemble the pump.
2. Inspect it.
3. Replace worn parts.

6.2 Bearing maintenance



These bearing lubrication sections list different temperatures of the pumped fluid. If the pump is Ex-certified and the temperature of the pumped fluid exceeds the permitted temperature values, then consult your ITT representative.



For Ex applications bearing replacement (all) is recommended after 17,500 hours of operation.

Bearing lubrication schedule

Type of bearing	First lubrication	Lubrication intervals
Oil-lubricated bearings	Add oil before you install and start the pump. Change the oil after 200 hours for new bearings.	After the first 200 hours, change the oil every 2000 operating hours or every three months.
Grease-lubricated bearings	Grease-lubricated bearings are initially lubricated at the factory.	Regrease bearings every 2000 operating hours or every three months.

6.2.1 Lubricating-oil requirements

Oil requirements based on temperature

For the majority of operating conditions, bearing temperatures run between 49°C | 120°F and 82°C | 180°F, and you can use an oil of ISO viscosity grade 68 at 38°C | 100°F. If temperatures exceed 82°C | 180°F, refer to the table for temperature requirements.

Temperature	Oil requirement
Bearing temperatures exceed 82°C 180°F	Use ISO viscosity grade 100 with bearing-frame cooling or finned-tube oil cooler. The finned-tube oil cooler is standard with the HT 3196 model and optional for all other models.
Pumped-fluid temperatures exceed 177°C 350°F	Use synthetic lubrication.

6.2.1.1 Oil volumes

Oil volume requirements

This table shows the required amount of oil for oil-lubricated bearings.

Frame	ml	Qts.	Oz.
STi	400	0.5	16
MTi	1400	1.5	47

6.2.1.2 Acceptable oil for lubricating bearings

Acceptable lubricants

Table 13: Acceptable lubricants

Brand	Lubricant type
Chevron	GST Oil 68
Exxon	Teresstic EP 68
Mobil	DTE Heavy Medium
Phillips 66	Turbine Oil VG68
Shell	Turbo T 68
Sunoco	Sunvis 968
Royal Purple	SYNFILM ISO VG 68 Synthetic Oil

6.2.2 Regrease the grease-lubricated bearings

NOTICE:

Risk of equipment damage. Ensure that the grease container, the greasing device, and the fittings are clean. Failure to do so can result in impurities entering the bearing housing while regreasing the bearings.

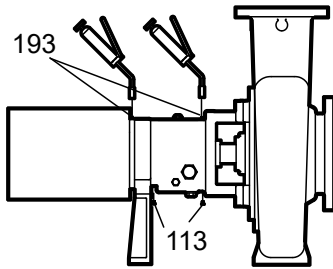

Figure 49: Bearing lubrication

1. Wipe dirt from the grease fittings.
2. Remove the two grease-relief plugs from the bottom of the frame.
3. Fill both of the grease cavities through the fittings with a recommended grease until the fresh grease comes out of the relief holes.
4. Make sure that the frame seals are seated in the bearing housing. If they are not, press them in place with the drains located at the bottom.
5. Reinstall the grease-relief plugs.
6. Wipe off any excess grease.
7. Recheck the alignment.

The bearing temperature usually rises after you regrease due to an excess supply of grease. Temperatures return to normal in about two to four operating hours as the pump runs and purges the excess grease from the bearings.

6.2.2.1 Lubricating-grease requirements

Precautions

NOTICE:

- Avoid equipment damage or decreased performance. Never mix greases of different consistencies (NLGI 1 or 3 with NLGI 2) or with different thickeners. For example, never mix a lithium-based grease with a polyurea based grease. If it is necessary to change the grease type or consistency, remove the rotor and old grease from the housing before regreasing.

Bearing temperature

Bearing temperatures are generally about 18°C | 20°F greater than bearing-housing outer surface temperatures.

This table shows the type of grease required for the operating temperature of the pump.

Bearing temperature	Type of grease
-15°C to 110°C 5°F to 230°F	Use a lithium-based mineral-oil grease with a consistency of NLGI 2.
Exceed 177°C 350°F	Use a high-temperature grease. Mineral-oil greases should have oxidation stabilizers and a consistency of NGLI 3.

Grease recommendations based on temperature

Most pumps use Sunoco 2EP grease. High temperature units that can pump fluids with a temperature greater than 177°C | 350°F use Mobil SCH32.

This table shows which brand of grease to use when lubricating the pump.

Brand	When temperature of pumped fluid is less than 177°C 350°F NLGI consistency 2	When temperature of pumped fluid is greater than 177°C 350°F NLGI consistency 3
Mobil	Mobilux EP2	SCH32
Exxon	Unirex N2	Unirex N3
Sunoco	Multipurpose 2EP	N/A
SKF	LGMT 2	LGMT 3

6.2.3 Lubricate the bearings after a shutdown period

1. Flush out the bearings and bearing frame with a light oil to remove contaminants. During flushing, make sure to rotate the shaft slowly by hand.
2. Flush the bearing housing with the proper lubricating oil to ensure oil quality after cleaning.
3. Refer to *Reassembly* section for proper bearing greasing procedure.

6.3 Shaft seal maintenance

6.3.1 Mechanical-seal maintenance



WARNING:

- The mechanical seal used in an Ex-classified environment must be properly certified.
-



CAUTION:

Running a mechanical seal dry, even for a few seconds, can cause seal failure and physical injury. Never operate the pump without liquid supplied to the mechanical seal.

Cartridge-type mechanical seals

Cartridge-type mechanical seals are commonly used. Cartridge seals are preset by the seal manufacturer and require no field settings. Cartridge seals installed by the user require disengagement of the holding clips prior to operation, allowing the seal to slide into place. If the seal has been installed in the pump by ITT, these clips have already been disengaged.

Other mechanical seal types

For other types of mechanical seals, refer to the instructions provided by the seal manufacturer for installation and setting.

Reference drawing

The manufacturer supplies a reference drawing with the data package. Keep this drawing for future use when you perform maintenance and seal adjustments. The seal drawing specifies the required flush fluid and attachment points.

Before you start the pump

Check the seal and all flush piping.

Mechanical seal life

The life of a mechanical seal depends on the cleanliness of the pumped fluid. Due to the diversity of operating conditions, it is not possible to give definite indications as to the life of a mechanical seal.

6.4 Disassembly

6.4.1 Disassembly precautions

**WARNING:**

- Failure to disconnect and lock out driver power may result in serious physical injury or death. Always disconnect and lock out power to the driver before performing any installation or maintenance tasks.
 - Electrical connections must be made by certified electricians in compliance with all international, national, state, and local rules.
 - Refer to driver/coupling/gear manufacturer's installation and operation manuals (IOM) for specific instructions and recommendations.
- Risk of serious personal injury. Applying heat to impellers, propellers, or their retaining devices can cause trapped liquid to rapidly expand and result in a violent explosion. This manual clearly identifies accepted methods for disassembling units. These methods must be adhered to. Never apply heat to aid in their removal unless explicitly stated in this manual.
- Handling heavy equipment poses a crush hazard. Use caution during handling and wear appropriate Personal Protective Equipment (PPE, such as steel-toed shoes, gloves, etc.) at all times.
- Precautions must be taken to prevent physical injury. The pump may handle hazardous and/or toxic fluids. Proper personal protective equipment should be worn. Pumpage must be handled and disposed of in conformance with applicable environmental regulations.
- Risk of serious physical injury or death from rapid depressurization. Ensure pump is isolated from system and pressure is relieved before disassembling pump, removing plugs, opening vent or drain valves, or disconnecting piping.
- Risk of serious personal injury from exposure to hazardous or toxic liquids. A small amount of liquid will be present in certain areas like the seal chamber upon disassembly.

**CAUTION:**

- Avoid injury. Worn pump components can have sharp edges. Wear appropriate gloves while handling these parts.

6.4.2 Tools required

In order to disassemble the pump, you need these tools:

- Bearing puller
- Brass drift punch
- Cleaning agents and solvents

- Dial indicators
- Feeler gauges
- Hex wrenches
- Hydraulic press
- Induction heater
- Leveling blocks and shims
- Lifting sling
- Micrometer
- Rubber mallet
- Screwdriver
- Snap-ring pliers
- Torque wrench with sockets
- Wrenches
- Lifting eyebolt (dependent on pump / motor size)

6.4.3 Drain the pump



WARNING:

Risk of serious injury or death in Ex-classified environments. If the pump is a Model NM3171, NM3196, 3198, CV3198, 3298, V3298, SP3298, 4150, 4550, or 3107, ignition due to static electric discharge is possible from plastic parts that are not properly grounded. If the pumped fluid is non-conductive, drain and flush the pump with a conductive fluid under conditions that will not allow for a spark to be released to the atmosphere.



CAUTION:

- Risk of physical injury. Allow all system and pump components to cool before handling.
 - If the pumped fluid is non-conductive, drain and flush the pump with a conductive fluid under conditions that will not allow for a spark to be released to the atmosphere.
-

1. Leave the suction pipe drain valve open to drain the pump casing as much as possible.
2. Leave the drain valve open and remove the drain plug located on the bottom of the pump housing. Do not reinstall the plug or close the drain valve until the reassembly is complete.
3. Remove the coupling guard.

6.4.4 Remove the coupling

1. Disconnect the coupling.
2. Remove the C-face adapter.
3. Remove the coupling-guard pump end-plate.

6.4.5 Remove the back pull-out assembly



WARNING:

Lifting and handling heavy equipment poses a crush hazard. Use caution during lifting and handling and wear appropriate Personal Protective Equipment (PPE, such as steel-toed shoes, gloves, etc.) at all times. Seek assistance if necessary.

1. Is your bearing frame oil lubricated?

- If No: Proceed to step 2.
- If Yes:
 1. Remove the bearing-frame drain plug (408A) in order to drain oil from the bearing frame.
 2. Replace the plug after the oil is drained.
 3. Remove the oil reservoir, if equipped.

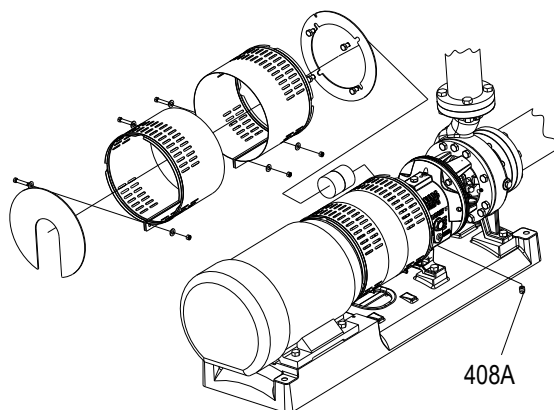

Figure 50: Back pull-out assembly removal (oil lubricated bearing frame)

Oil analysis should be part of a preventive maintenance program that determines the cause of a failure. Save the oil in a clean container for inspection.

2. The back pull out assembly consists of all parts except the casing (100). The casing (100) can remain on the foundation and in the piping, if it is not the casing itself, which must be repaired. Drain the casing, by removing the casing drain plug (if equipped).
3. Does your pump use a C-face adapter?
 - If Yes: Place one sling from the hoist through the frame adapter (108) or frame (228A) for the STi and a second sling from the hoist through the C-face adapter.
 - If No: Place a sling from the hoist through the frame adapter (108) or the frame (228A) for the STi.

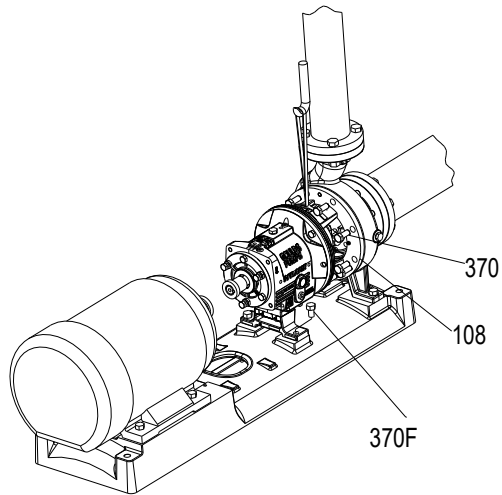

Figure 51: Back pull-out assembly removal (with C-face adapter)

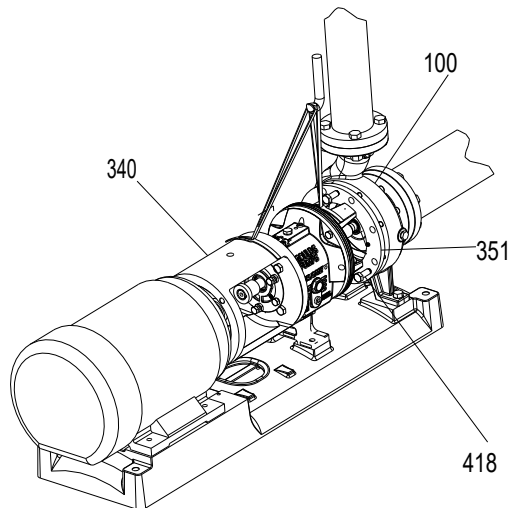

Figure 52: Back pull-out assembly removal (without C-face adapter)

4. Remove the hold-down bolts of the bearing frame foot.
5. Tighten the jackscrews evenly, using an alternating pattern, in order to remove the back pull-out assembly.
You can use penetrating oil if the adapter to the casing joint is corroded.
6. Remove the back pull-out assembly from the casing (100).

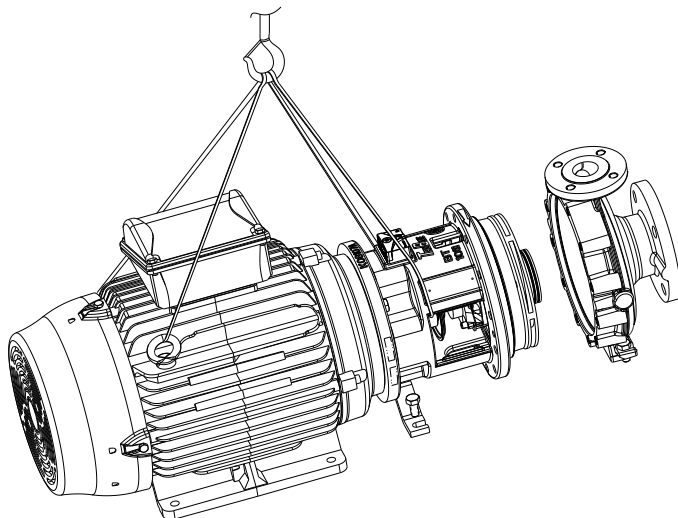

Figure 53: Back pullout

7. Mark and remove the shims from under the frame foot and save them for reassembly.
8. Remove and discard the casing gasket.
You will insert a new casing gasket during reassembly.
9. Remove the jackscrews.
10. Clean all gasket surfaces.
Clean surfaces prevent the casing gasket from partially adhering to the casing due to binders and adhesives in the gasket material.

6.4.6 Remove the coupling hub

1. Clamp the frame adapter securely to the workbench.
2. Remove the coupling hub.
Mark the shaft for relocation of the coupling hub during reassembly.

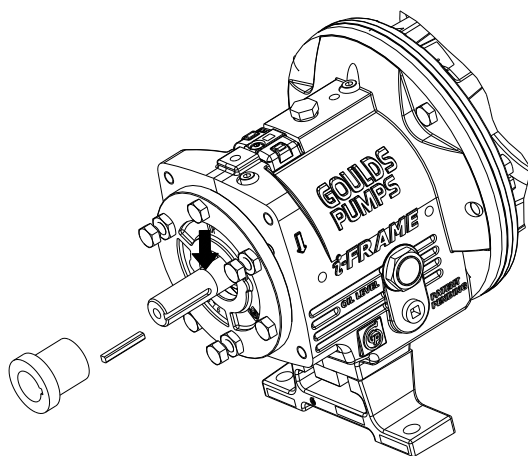

Figure 54: Coupling hub removal

6.4.7 Impeller removal

6.4.7.1 Remove the impeller (STi, MTi)



WARNING:

Risk of severe physical injury or death from explosion of trapped liquid. Never use heat to remove parts unless explicitly stated in this manual.



CAUTION:

Risk of physical injury from sharp edges. Wear heavy work gloves when handling impellers.

1. Slide the shaft wrench (A05107A or A01676A) over the shaft (122) and key.
2. Rotate the impeller (101) clockwise (viewed from the impeller end of the shaft) and raise the wrench off of the work surface.
3. To loosen the impeller, quickly turn it counter-clockwise (viewed from the impeller end of the shaft) while impacting the wrench handle on the workbench or a solid block.

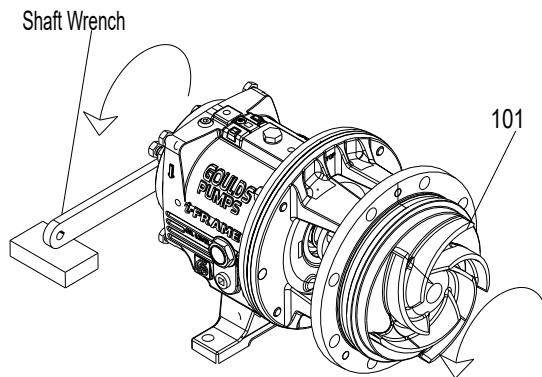

Figure 55: Loosen impeller

4. Repeat step 3 until the impeller becomes loose.
5. Remove and discard the impeller O-ring (412A). You will insert a new O-ring during reassembly.

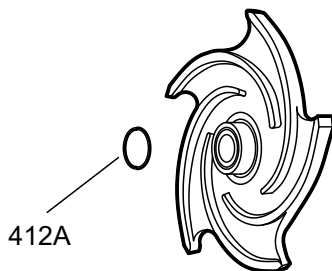

Figure 56: O-ring for models 3196, HT 3196, NM 3196, 3198, CV 3198 and 3796

If the impeller cannot be removed by the previous methods, cut the shaft between the gland and the frame, remove the impeller, stuffing-box cover, gland, sleeve, and shaft end as a unit. Do not apply heat.

6.4.8 Shaft guard removal (if provided)

6.4.8.1 Remove the shaft guard (STi)

1. Remove the bolt for each shaft guard half that mounts the halves to each side of the frame.
2. Retain each guard half with fasteners for reinstallation.

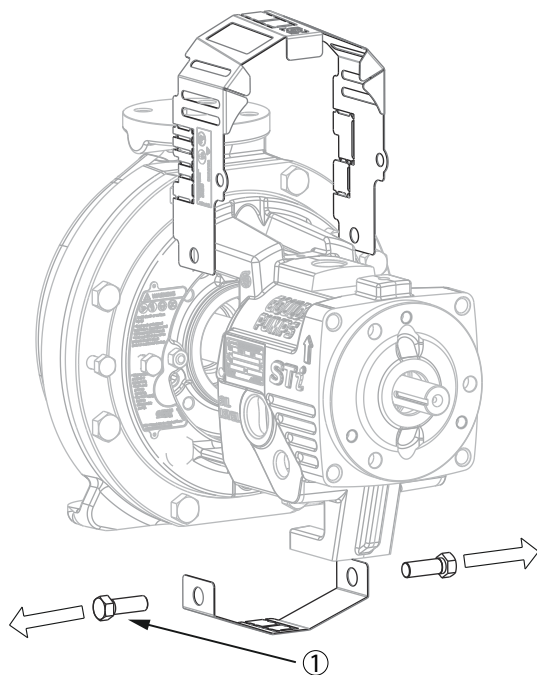
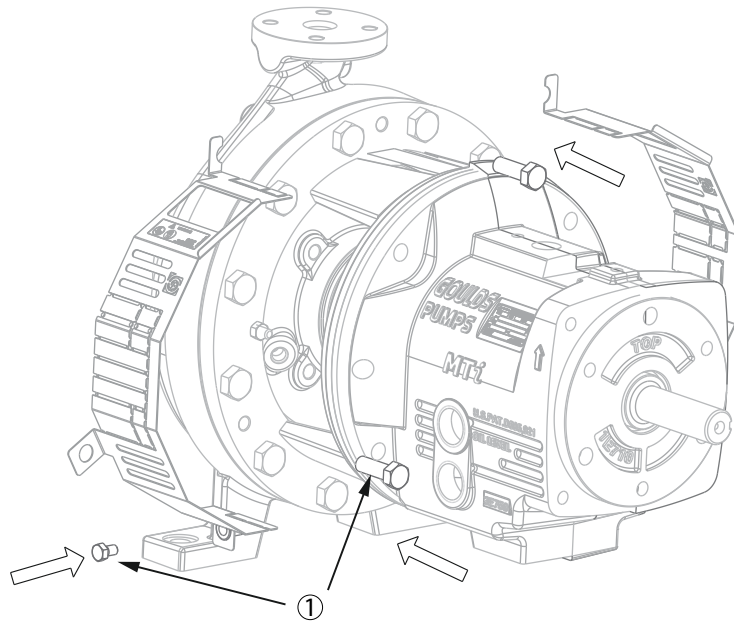

Figure 57: Shaft guard removal

6.4.8.2 Remove the shaft guard (MTi/LTi, XLTi/i17)

1. Remove the bolt for each shaft guard half that mounts the halves to the brackets on each side.
2. Do not remove the clip that retains the bolt on the guard half to maintain a captive fastener.
3. Retain each guard half with fasteners for reinstallation.



Item	Description
1.	Mounting bolt

Figure 58: Shaft guard removal

6.4.9 Seal-chamber cover removal

Seal-chamber removal procedures

Choose from one of these procedures to remove the seal-chamber cover.

Table 14: Procedures for seal-chamber cover removal by model

Model	Procedure
3196, CV 3196, HT 3196, LF 3196, 3796	Remove the seal-chamber cover.
NM 3196, 3198, CV 3198	Remove the seal-chamber cover and/or backplate.

6.4.10 Remove the seal-chamber cover and backplate (NM 3196, 3198, CV 3198)

1. Remove the gland nuts or seal-chamber stud nuts (355).
2. Remove the backplate stud nuts (370H).
3. Remove the backplate (184).

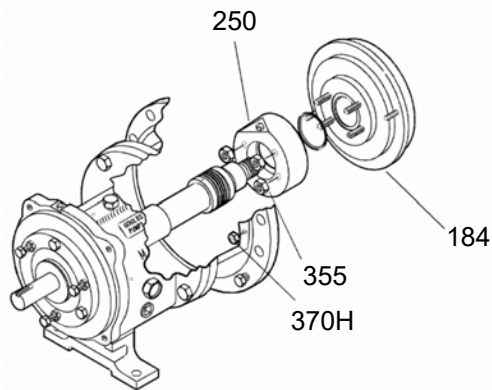

Figure 59: Bearing housing and bearing removal

4. Remove the shaft sleeve (126).
The mechanical seal is attached to the sleeve.
5. Loosen the set screws and slide the rotary portion off the sleeve.
6. On the 3198, remove the PTFE sleeve:
 - a) Remove the mechanical seal from the sleeve.
 - b) Slice the sleeve lengthwise with a sharp knife.
7. Remove the stationary seat and the gland or the seal chamber with the gland gaskets.

NOTICE:

Be careful with the mechanical seal. Carbon or ceramic components are brittle and easily broken.

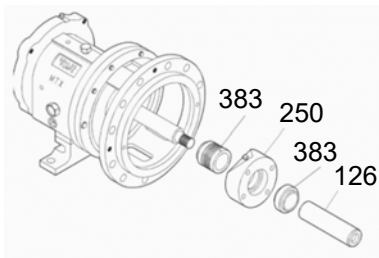

Figure 60: Remove the stationary seat and the gland

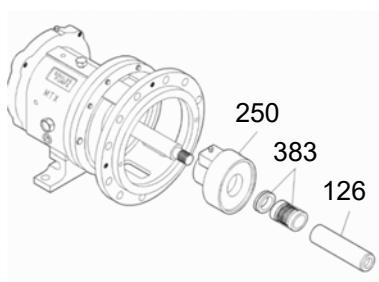

Figure 61: Stationary seat and seal chamber removal

6.4.11 Remove the frame adapter (MTi)

The 3198 frame adapter is not interchangeable with the adapter of any other model.

1. Remove the dowel pins (469B) and the bolts (370B).
2. Remove the frame adapter (108).
3. Remove and discard the gasket (360D).
You will install a new gasket during reassembly.

6.4.12 Remove the inboard labyrinth oil seal

Labyrinth oil-seal O-rings are part of the 3196 maintenance kits, and they are sold separately.

1. Determine the fit of your labyrinth oil seal.

Table 15: Labyrinth oil-seal fit

Model	Type of fit
STi	O-ring fit into the bearing-frame adapter (228A)
MTi	O-ring fit into the frame adapter

2. Remove the O-rings (497H and 497J) and the seal (333A).

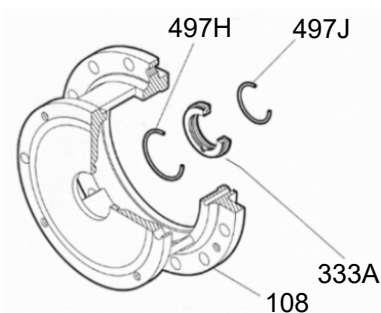

Figure 62: O-ring removal

6.4.13 Power-end disassembly

6.4.13.1 Disassemble the power end (STi, MTi)

1. Remove the clamp screws (370C) and back off the jam nuts (423).
2. Tighten the jack screws (370D) evenly to move the bearing housing (134) out of the bearing frame (228A).
3. Remove the shaft assembly from the bearing frame (228A).

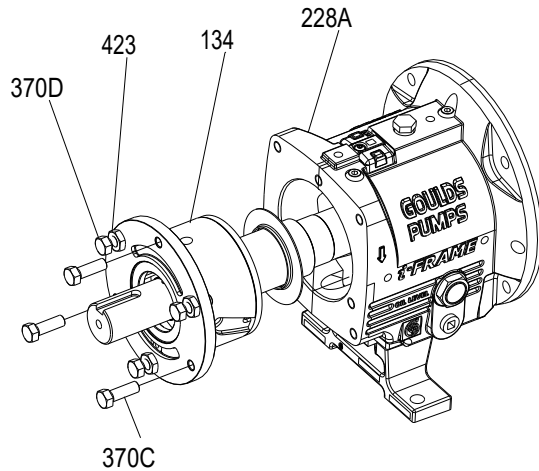

Figure 63: Shaft assembly removal

4. Remove the jack screws (370D) with nuts (423).
5. Remove the bearing housing O-ring (496) and the bearings.
6. Remove the outboard bearing retaining snap ring (361A).

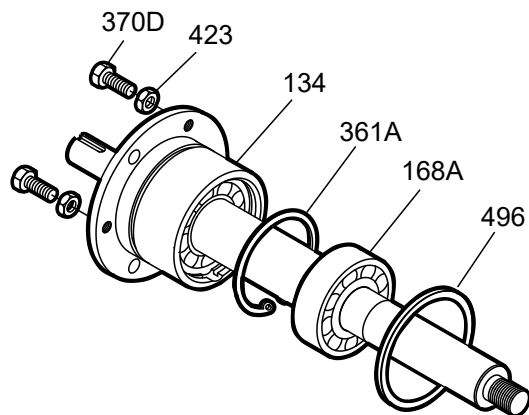

Figure 64: Outboard bearing retaining snap ring removal

7. Remove the bearing housing (134) and bearings (112A and 168A) from the shaft (122).

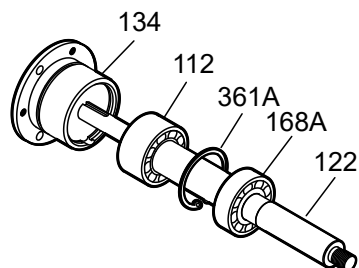

Figure 65: Bearing housing and bearings removal

8. Remove the bearing locknut (136) and bearing lock washer (382).
9. Remove the inboard bearing (168A).
10. Remove the outboard bearing (112A).

NOTICE:

Use force only on the inner race when pressing bearings from the shaft. Failure to do so may result in equipment damage.

NOTICE:

Do not reuse bearings if removed from shaft. Doing so may result in equipment damage. Replace the bearings before reassembly.

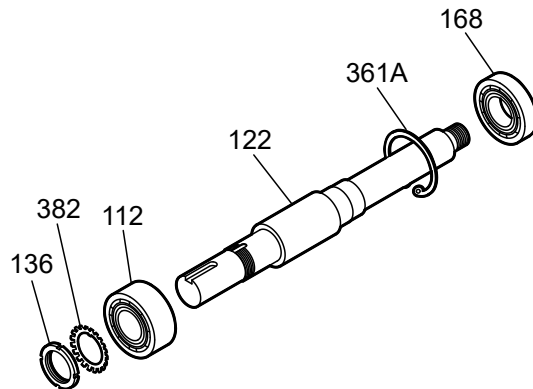

Figure 66: Outboard bearing removal

6.4.13.2 Disassemble the power end (STi and MTi with duplex bearings)

1. Remove the clamp screws (370C) and back off the jam nuts (423).
2. Tighten the jack screws (370D) evenly to move the bearing housing (134) out of the bearing frame (228A).
3. Remove the shaft assembly from the bearing frame (228A).

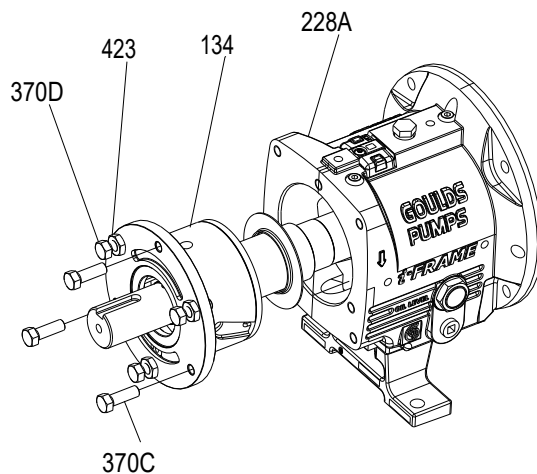

Figure 67: Shaft assembly removal

4. Remove the jack screws (370D) with the nuts (423).

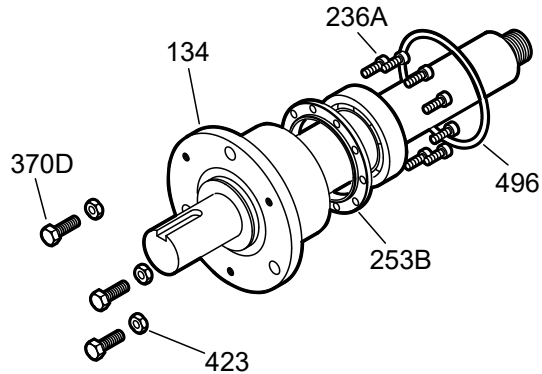

Figure 68: Jack screw removal

5. Remove the bearing housing O-ring (496).
6. Remove the clamp ring screws (236A) and separate the clamp ring (253B) from the bearing housing (134).

You must remove the bearings before you can remove the clamp ring from the shaft.

7. Remove the bearing housing (134) and the bearings (112A and 168A) from the shaft (122).

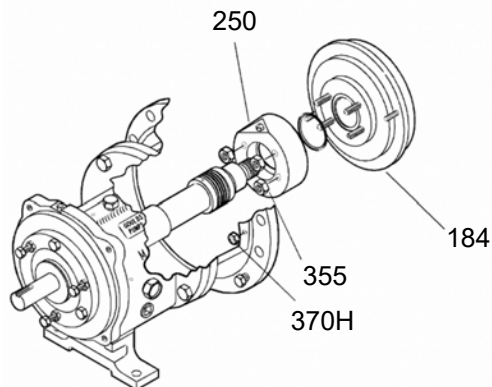

Figure 69: Bearing housing and bearing removal

8. Remove the inboard bearing (168A).

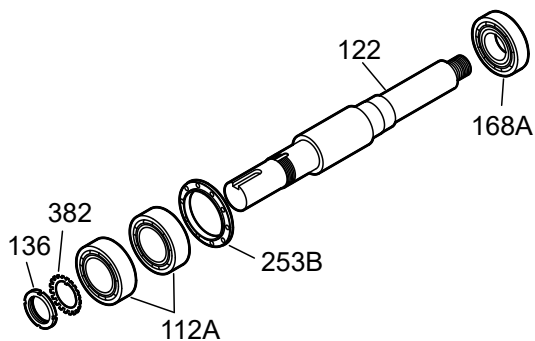

Figure 70: Inboard bearing removal

9. Remove the bearing locknut (136) and bearing lockwasher (382).
10. Remove the outboard bearings (112A).

NOTICE:

Use force only on the inner race when pressing bearings from the shaft. Failure to do so may result in equipment damage.

NOTICE:

Do not reuse bearings if removed from shaft. Doing so may result in equipment damage. Replace the bearings before reassembly.

11. Remove the outboard labyrinth oil seal (332A) from the bearing housing (134). Remove the O-rings (497F and 497G) if it is necessary. Labyrinth oil seal O-rings are part of the 3196 maintenance kits and they are sold separately.

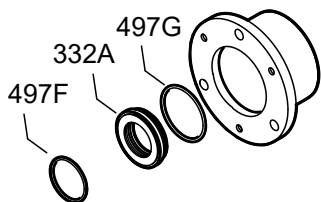

Figure 71: Outboard labyrinth oil seal removal

6.4.14 Disassemble the bearing frame

1. Remove these plugs from the bearing frame (228A).
 - oil-fill plug (113A)
 - oil-drain plug (408A)
 - sight-oiler plug (408J)
 - four oil mist/grease connection plugs (408H)
 - oil-cooler inlet and outlet plugs (408L and 408M) or oil cooler
2. For the MTi models, remove the bearing frame foot-to-frame bolts (370F) and the frame foot (241).

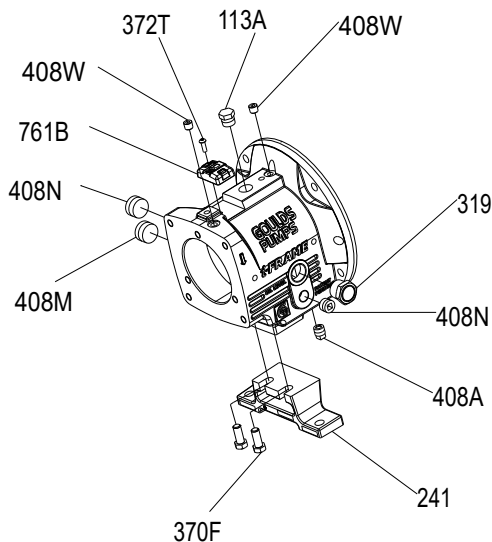

Figure 72: Plug removal

6.4.15 Guidelines for i-ALERT[®] Equipment Health Monitor disposal

Precautions



WARNING:

- Explosive hazard and risk of personal injury. Heating to high temperatures could cause combustion of the condition monitor. Never heat the condition monitor to temperatures in excess of 149°C | 300°F or dispose of in a fire.

Guidelines

The battery contained in the condition monitor does not contain enough lithium to qualify as reactive hazardous waste. Use these guidelines when disposing of the condition monitor.

- The condition monitor is safe for disposal in the normal municipal waste stream.
- Adhere to local laws when you dispose of the condition monitor.

6.4.16 Disassemble the C-face adapter



WARNING:

Risk of personal injury and equipment damage from dropping or tipping motor. The motor must be properly supported with a clean, uncorroded eye bolt or a strap under both ends.

1. Loosen the motor-mounting bolts and remove the motor.

Table 16: Required number of motor-mounting bolts

This table shows the number of motor-mounting bolts.

Pump frame	Motor frame	Number of bolts
STi	All	4
MTi	143-286	4
	324-365	8

2. Loosen the bolts attached to the bearing-frame flange and remove the C-face adapter from the bearing frame.

6.5 Pre-assembly inspections

Guidelines

Before you assemble the pump parts, make sure you follow these guidelines:

- Inspect the pump parts according to the information in these pre-assembly topics before you reassemble your pump. Replace any part that does not meet the required criteria.
- Make sure that the parts are clean. Clean the pump parts in solvent in order to remove oil, grease, and dirt.

NOTICE:

Protect machined surfaces while cleaning the parts. Failure to do so may result in equipment damage.

6.5.1 Replacement guidelines

Casing check and replacement



WARNING:

Risk of death or serious injury. Leaking fluid can cause fire and/or burns. Inspect and ensure gasket sealing surfaces are not damaged and repair or replace as necessary.

Inspect the casing for cracks and excessive wear or pitting. Thoroughly clean gasket surfaces and alignment fits in order to remove rust and debris.

Repair or replace the casing if you notice any of these conditions:

Casing areas to inspect

The arrows point to the areas to inspect for wear on the casing:

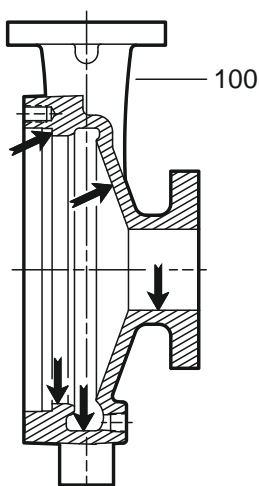

Figure 73: 3196, HT 3196, LF 3196, NM 3196, and 3198 casing

Impeller replacement

This table shows the criteria for replacing the impeller:

Impeller parts	When to replace
Impeller vanes	<ul style="list-style-type: none"> When grooved deeper than 1.6 mm 1/16 in., or When worn evenly more than 0.8 mm 1/32 in.
Pumpout vanes	When worn or bent more than 0.8 mm 1/32 in.
Vane edges	When you see cracks, pitting, or corrosion damage

Impeller areas to inspect

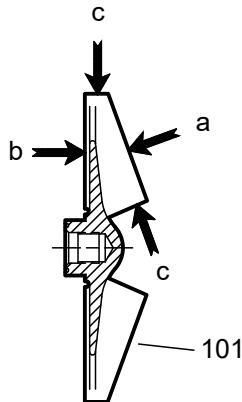

Figure 74: Areas to inspect for wear on the 3196 impeller.

Frame adapter check and replacement

- Replace the frame adapter if it has cracks or excessive corrosion damage.
- Make sure the gasket surface is clean.

Labyrinth seal replacement

Replace the labyrinth-seal O-ring if it has cuts and cracks.

Gaskets, O-rings, and seats replacement



WARNING:

Risk of death or serious injury. Leaking fluid can cause fire and/or burns. Replace all gaskets and O-rings at each overhaul or disassembly.

- Replace all gaskets and O-rings at each overhaul and disassembly.
- Inspect the seats. They must be smooth and free of physical defects. In order to repair worn seats, skin cut them in a lathe while you maintain dimensional relationships with other surfaces.
- Replace parts if the seats are defective.



WARNING:

Risk of serious personal injury or property damage. Fasteners such as bolts and nuts are critical to the safe and reliable operation of the product. Ensure appropriate use of fasteners during installation or reassembly of the unit.

- Use fasteners of the proper size and material only.
- Replace all corroded fasteners.
- Ensure that all fasteners are properly tightened and that there are no missing fasteners.

6.5.1.1 Fastening



WARNING:

Risk of serious personal injury or property damage. Fasteners such as bolts and nuts are critical to the safe and reliable operation of the product. Ensure appropriate use of fasteners during installation or reassembly of the unit.

- Use fasteners of the proper size and material only.
- Replace all corroded fasteners.
- Ensure that all fasteners are properly tightened and that there are no missing fasteners.

6.5.2 Shaft and sleeve replacement guidelines

Two types of sleeves

The 3198 and CV 3198 is offered with either a metallic sleeve that uses the standard 3196 shaft or a PTFE sleeve. The PTFE sleeve requires a special shaft and a different inboard labyrinth oil seal.

Shaft measurements check

Replace the shaft (122) if any measurements exceed acceptable values. See Bearing fits and tolerances.

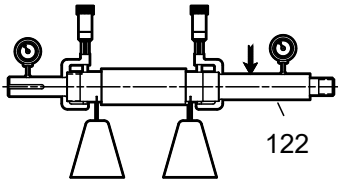

Figure 75: Shaft measurements check

Straightness check

Replace the shaft (122) if runout exceeds the values in this table:

Table 17: Shaft runout tolerances for sleeve fit and coupling fit

	Sleeve fit in millimeters inches	Coupling fit in millimeters inches
With sleeve	0.025 0.001	0.025 0.001
Without sleeve	0.051 0.002	0.025 0.001

Shaft and sleeve check

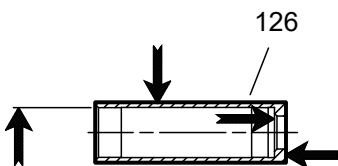

Figure 76: Shaft and sleeve check

- Check the shaft and sleeve (126) surface for grooves and pitting.

- Replace the shaft and sleeve if any grooves or pits are found.

6.5.3 Bearing-frame inspection

Checklist

Check the bearing frame for these conditions:

- Visually inspect the bearing frame and frame foot for cracks.
- Check the inside surfaces of the frame for rust, scale, or debris. Remove all loose and foreign material.
- Make sure that all lubrication passages are clear.
- If the frame has been exposed to pumped fluid, inspect the frame for corrosion or pitting.
- Inspect the inboard bearing bore. If bore dimensions are outside the measurements in [6.5.8 Bearing fits and tolerances on page 100](#), replace the bearing frame.

Surface inspection locations

This figure shows the areas to inspect for wear on the bearing frame inside and outside surface.

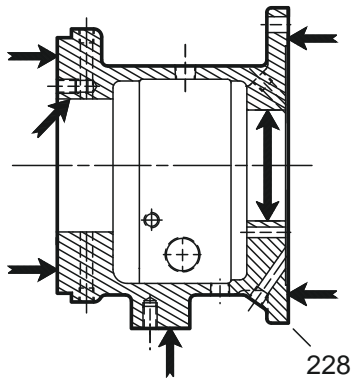

Figure 77: Bearing frame surface inspection locations

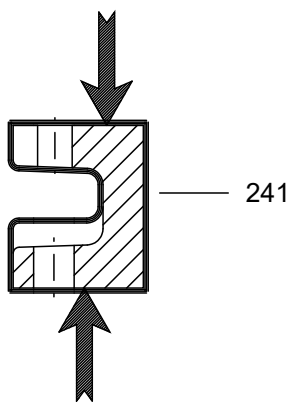

Figure 78: Frame foot surface inspection locations

6.5.4 C-face adapter inspection

Checklist

- Visually inspect the C-face adapter (340) for cracks.

- Check all surfaces for rust, scale, or debris and remove all loose and foreign material.
- Check for corrosion or pitting.

This figure shows the areas to inspect for cracks on the C-face adapter.

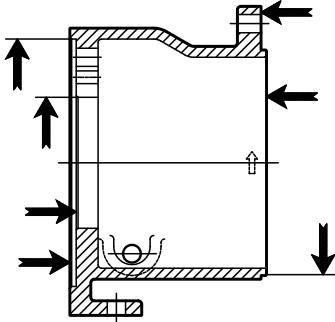

Figure 79: C-face adapter inspection locations

6.5.5 Seal chamber and stuffing box cover inspection

Checklist

Perform these checks when you inspect the seal chamber and stuffing box cover:

- Make sure that these surfaces are clean:
 - Seal chamber and stuffing box cover
 - Mounting
- Make sure there is no pitting or wear greater than 3.2 mm | 1/8 in. deep.
Replace the seal chamber and stuffing box cover if pitting or wear exceeds this measurement.
- Inspect the machined surfaces and mating faces noted in the figures.

These images point to the areas to inspect:

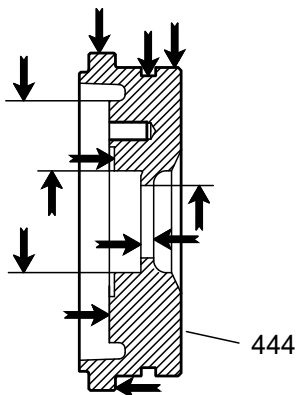

Figure 80: NM 3196 backplate

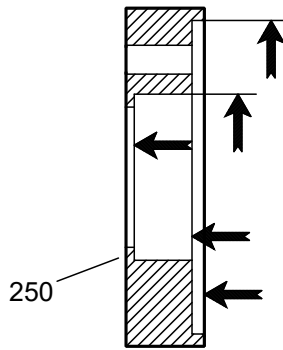

Figure 81: NM 3196 seal chamber

6.5.6 Bearings inspection

Condition of bearings

Do not reuse bearings. The condition of the bearings provides useful information on operating conditions in the bearing frame.

Checklist

Perform these checks when you inspect the bearings:

- Inspect the bearings for contamination and damage.
- Note any lubricant condition and residue.
- Inspect the ball bearings to see if they are loose, rough, or noisy when you rotate them.
- Investigate any bearing damage to determine the cause. If the cause is not normal wear, correct the issue before you return the pump to service.

6.5.7 Bearing-housing inspection

Checklist

- Inspect the bearing-housing (134) bore. If bore dimensions are outside the measurements in [6.5.8 Bearing fits and tolerances on page 100](#), replace the bearing housing.
- Visually inspect the bearing housing for cracks and pits.

Checklist for specific models

This table shows bearing-housing checks that are required for specific models of pump.

Frame	Bearing-housing check
STi and MTi	Ensure that the snap-ring groove is not cracked.

Inspection locations

The following images point to the areas to inspect on the bearing housing.

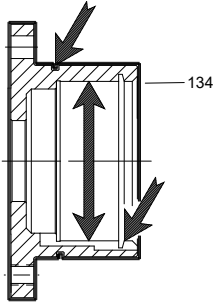

Figure 82: STi and MTi bearing housing

6.5.8 Bearing fits and tolerances

This table references the bearing fits and tolerances according to the ABEC I standard.

	STi millimeters inches	MTi millimeters inches	LTi millimeters inches	XLT-i, i-17 millimeters inches
Shaft OD Inboard	35.014 1.3785 35.004 1.3781	45.014 1.7722 45.004 1.7718	55.016 2.1660 55.004 2.1655	65.016 2.5597 65.004 2.5592
Clearance	0.025 0.0010 tight 0.003 0.0001 tight	0.025 0.0010 tight 0.003 0.0001 tight	0.030 0.0012 tight 0.003 0.0001 tight	0.030 0.0012 tight 0.003 0.0001 tight
Bearing ID Inboard	35.000 1.3780 34.989 1.3775	45.000 1.7717 44.988 1.7712	55.000 2.1654 54.986 2.1648	65.000 2.5591 64.986 2.5585
Frame ID Inboard	72.000 2.8346 72.017 2.8353	100.000 3.9370 100.023 3.9379	120.000 4.7244 120.023 4.7253	140.000 5.5118 140.025 5.5128
Clearance	0.030 0.0012 loose 0.000 0.0000 loose	0.038 0.0015 loose 0.000 0.0000 loose	0.038 0.0015 loose 0.000 0.0000 loose	0.043 0.0017 loose 0.000 0.0000 loose
Bearing OD Inboard	72.000 2.8346 71.986 2.8341	100.000 3.9370 99.985 3.9364	120.000 4.7244 119.985 4.7238	140.000 5.5118 139.982 5.5111
Shaft OD Outboard	30.013 1.1816 30.002 1.1812	45.014 1.7722 45.004 1.7718	50.013 1.9696 50.002 1.9686	65.016 2.5597 65.004 2.5592
Clearance	0.023 0.0009 tight 0.003 0.0001 tight	0.025 0.0010 tight 0.003 0.0001 tight	0.025 0.0010 tight 0.003 0.0001 tight	0.030 0.0012 tight 0.003 0.0001 tight
Bearing ID Outboard	30.000 1.811 29.990 1.1807	45.000 1.7717 44.988 1.7712	50.000 1.9685 49.987 1.9680	65.000 2.5591 64.986 2.5585
Housing ID Outboard	72.004 2.8348 72.017 2.8353	100.007 3.9373 100.023 3.9379	110.007 4.3310 110.023 4.3316	140.007 5.5121 140.025 5.5128
Clearance	0.030 0.0012 loose 0.005 0.0002 loose	0.038 0.0015 loose 0.008 0.0003 loose	0.038 0.0015 loose 0.008 0.0003 loose	0.043 0.0017 loose 0.008 0.0003 loose
Bearing OD Outboard	72.000 2.8346 71.986 2.8341	100.000 3.9370 99.985 3.9364	110.000 4.3307 109.985 4.3301	140.000 5.5118 139.982 5.5111

6.6 Reassembly

6.6.1 Assemble the rotating element and the bearing frame (STi and MTi)



CAUTION:

Risk of physical injury from hot bearings. Wear insulated gloves when using a bearing heater.

NOTICE:

Ensure that the pipe threads are clean. Apply thread sealant to the plugs and fittings. Failure to do so may result in oil leaks and equipment damage.

NOTICE:

There are several methods used to install bearings. The recommended method is to use an induction heater that heats as well as demagnetizes the bearings. Failure to use this method may result in equipment damage.

1. Prepare the bearing frame (228) as follows (see the illustration):
 - a) Install the oil-fill plug (113A).
 - b) Install the oil-drain plug (408A).
 - c) Install the sight glass (319).
 - d) Install the sight oiler plug (408J).
 - e) Install the plug for the oil-cooler inlet (408L).
 - f) Install the plug for the oil-cooler outlet (408M).
 - g) Install four oil-mist connection plugs (408H).

Or: Install two grease fittings (193) and two grease-relief plugs (113).

 - h) Attach the bearing-frame foot (241) and fasten the bolts (370F) by hand.

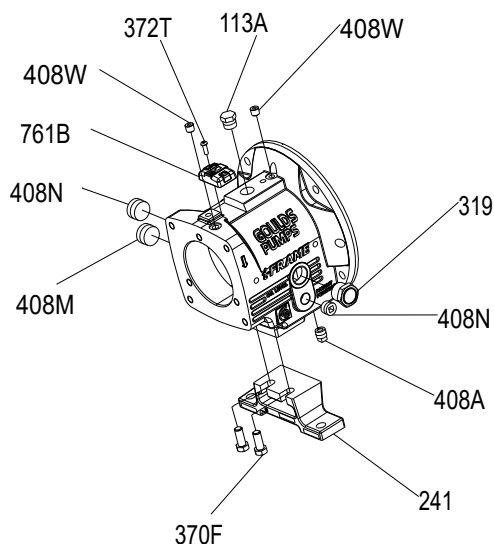

Figure 83: Oil mist connection plugs

2. Install the outboard bearing (112A) on the shaft (122).

The regreaseable bearing has a single shield. The outboard bearing is installed with the shield toward the impeller.

- a) Inspect the shaft (122) to ensure that it is clean, dimensionally correct, and is free of nicks and burrs.
- b) Lightly coat the bearing seating with a thin film of oil.
- c) Remove the bearing (112) from its packaging.
- d) Wipe the preservative from the bearing (112) bore and outer diameter.
- e) Use an induction heater with a demagnetizing cycle to heat the bearing (112) to an inner ring temperature of 110 °C | 230 °F.
- f) Position the bearing (112) on the shaft (122) against the shoulder and snug the locknut (136) against the bearing until it is cool.

The locknut prevents the bearing from moving away from the shaft shoulder as it cools.

- g) Remove the bearing locknut (136) after the bearing (112) cools.
3. Put the lockwasher (382) onto the shaft (122).
4. Thread the locknut (136) onto the shaft (122) and tighten it until it is snug.
5. Bend the tangs of the lockwasher into the slots of the locknut.
6. Put the bearing-retaining ring (361A) onto the shaft (122).
Make sure that the flat side of the ring is towards the bearing.
7. Coat the inner surfaces of the bearings with lubricant.
8. Put the inboard bearing (168) onto the shaft (122).

The regreaseable bearing has a single shield. Make sure that the bearing is installed with the shield away from the impeller.

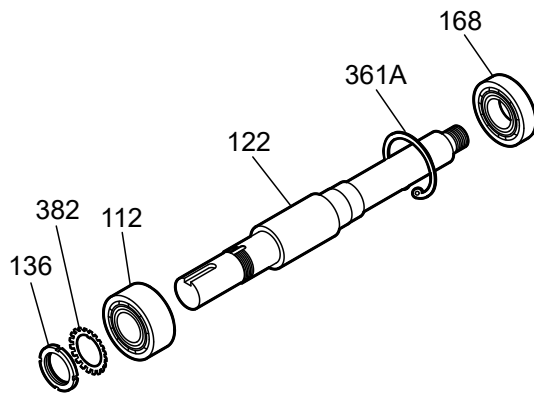

Figure 84: Inboard bearing reassembly

9. Prepare the shaft for assembly as follows (see the illustration):
 - a) Install a new O-ring (496).
 - b) Coat the outside of the outboard bearing (112A) with oil.
 - c) Coat the bore of the bearing housing (134) with oil.
 - d) Put the bearing housing (134) onto the shaft.

Do not use force.

- e) Insert the bearing-retaining ring (361A) into the bore groove of the bearing housing (134).

NOTICE:

Ensure that the space between the ends of the retaining ring are located in the oil return groove. Failure to do so will cause oil-flow obstruction and result in equipment damage.

Make sure that the shaft rotates freely.

- f) Install the outboard labyrinth oil-seal (332A) into the bearing housing (134).

Place the drain slots of the oil seal at the bottom position (6 o'clock).

Make sure that the edges of the keyway are free from burrs. To protect the O-ring, cover the keyway lengthwise with a piece of electrical tape before you install the oil seal.

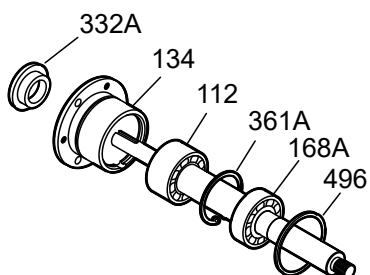

Figure 85: Outboard labyrinth oil-seal reassembly

10. Install the shaft assembly into the bearing frame as follows (see the illustration):
- Coat the outside of the bearing housing (134) with oil.
 - Coat all the internal surfaces of the bearing frame (228) with oil.
 - Install the shaft assembly into the bearing frame (228). (Place "Top" position at 12 o'clock).

Make sure that the shaft rotates freely.

- Install the clamp bolts (370C) in the bearing housing (134) and tighten by hand.
- Install the jack bolts (370D) with the locknuts (423) in the bearing housing (134) and tighten by hand.

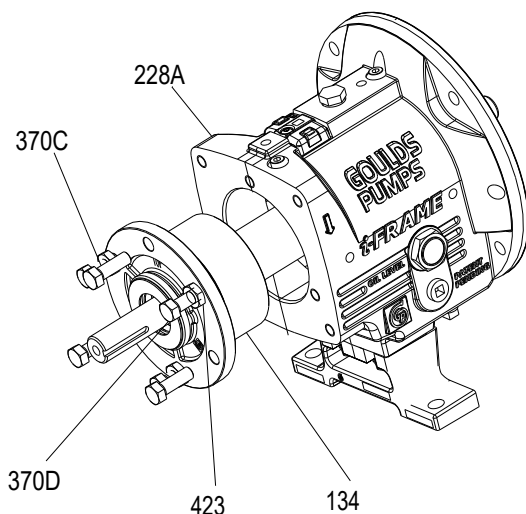

Figure 86: Jack bolt and locknut reassembly

6.6.2 Assemble the rotating element and the bearing frame (STi and MTi with duplex bearings)



WARNING:

Lifting and handling heavy equipment or components poses a crush hazard. Use caution during lifting and handling and wear appropriate Personal Protective Equipment (PPE, such as steel-toed shoes, gloves, etc.) at all times. Seek assistance if necessary.



CAUTION:

Risk of physical injury from hot bearings. Wear insulated gloves when using a bearing heater.

NOTICE:

Ensure that the pipe threads are clean. Apply thread sealant to the plugs and fittings. Failure to do so may result in oil leaks and equipment damage.

NOTICE:

There are several methods used to install bearings. The recommended method is to use an induction heater that heats as well as demagnetizes the bearings. Failure to use this method may result in equipment damage.

1. Prepare the bearing frame (228) as follows (see the illustration):
 - a) Install the oil-fill plug (113A).
 - b) Install the oil-drain plug (408A).
 - c) Install the sight glass (319).
 - d) Install the sight oiler plug (408J).
 - e) Install the plug for the oil-cooler inlet (408L).
 - f) Install the plug for the oil-cooler outlet (408M).
 - g) Install four oil-mist connection plugs (408H).

Or: Install two grease fittings (193) and two grease-relief plugs (113).

 - h) Attach the bearing-frame foot (241) and fasten the bolts (370F) by hand.

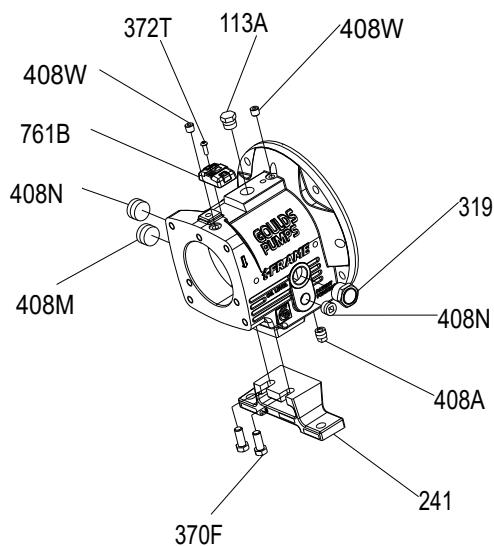

Figure 87: Bearing frame foot reassembly

2. Install the outboard bearings (112A) on the shaft (122).

The regreasable bearing has a single shield. Make sure that the bearing is installed with the shield away from the impeller.

The duplex bearings are mounted back-to-back. Make sure that the orientation of the bearings are correct.

- a) Inspect the shaft (122) to ensure that it is clean, dimensionally correct, and is free of nicks and burrs.

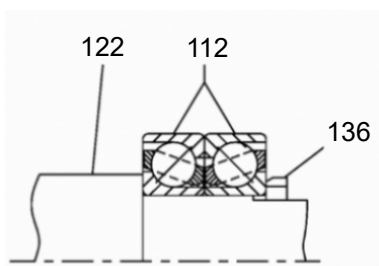

Figure 88: Shaft inspection

- b) Lightly coat the bearing seating with a thin film of oil.
 - c) Remove the bearings (112) from their packaging.
 - d) Wipe the preservative from the bearing (112) bore and outer diameter.
 - e) Use an induction heater with a demagnetizing cycle to heat both bearings (112) to an inner ring temperature of 110 °C | 230 °F.
 - f) Place both bearings (112) on the shaft (122) with the large outer races together (back-to-back).
 - g) Position the bearings (112) on the shaft (122) against the shoulder and snug the locknut (136) against the bearings until they are cool.
The locknut prevents the bearings from moving away from the shaft shoulder as they cool. Rotate the outer bearing rings relative to each other as they are placed on the shaft to assure good alignment.
 - h) Remove the bearing locknut (136) after the bearings (112) are cool.
3. Put the lockwasher (382) onto the shaft (122).

4. Thread the locknut (136) onto the shaft (122) and tighten it until it is snug.
5. Bend the tangs of the lockwasher into the slots of the locknut.
6. Place the bearing-clamp ring (253B) onto the shaft (122).

Make sure that the orientation of the bearing-clamp ring is correct.

7. Coat the inner surfaces of the bearings with lubricant.
8. Put the inboard bearing (168A) onto the shaft (122).

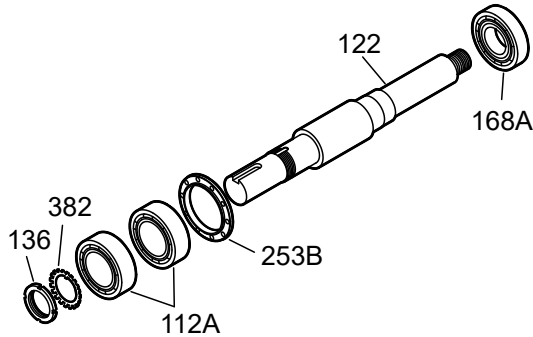

Figure 89: Inboard bearing reassembly

9. Install the bearing housing as follows (see the illustration):
 - a) Coat the outside of the outboard bearing (112A) with oil.
 - b) Coat the bore of the bearing housing (134) with oil.
 - c) Put the bearing housing (134) onto the shaft.

Do not use force.

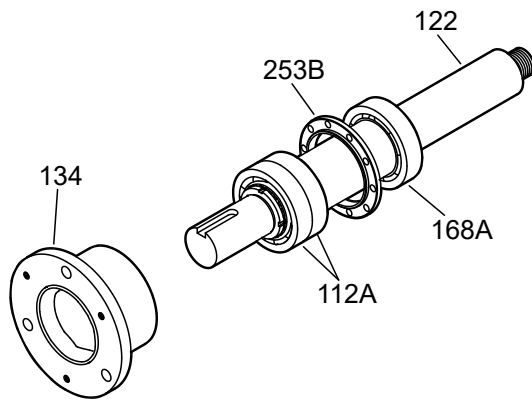

Figure 90: Bearing housing reassembly

10. Prepare the shaft for assembly as follows (see the illustration):
 - a) Place the bearing-clamp ring (253B) onto the shaft (122).
 - b) Fasten the clamp-ring bolts (236A) crosswise.
See the specified torque values.
Make sure that the shaft rotates freely.
 - c) Install a new O-ring (496).
 - d) Install the outboard labyrinth oil-seal (332A) into the bearing housing (134).
Place the drain slots of the oil seal at the bottom position (6 o'clock).

Make sure that the edges of the keyway are free from burrs. To protect the O-ring, cover the keyway lengthwise with a piece of electrical tape before you install the oil seal.

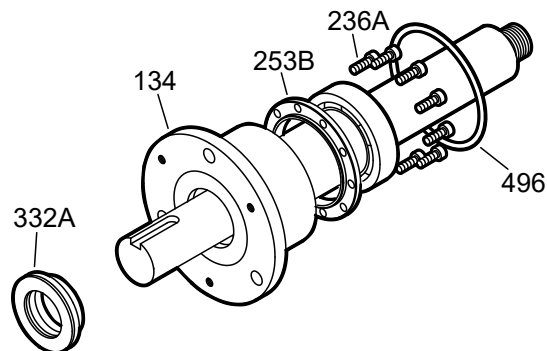

Figure 91: Outboard labyrinth oil seal reassembly

11. Install the shaft assembly into the bearing frame as follows (see the illustration):
 - a) Coat the outside of the bearing housing (134) with oil.
 - b) Coat all the internal surfaces of the bearing frame (228) with oil.
 - c) Install the shaft assembly into the bearing frame (228). (Place "Top" position at 12 o'clock).
Make sure that the shaft rotates freely.
 - d) Install the clamp bolts (370C) in the bearing housing (134) and tighten by hand.
 - e) Install the jack bolts (370D) with the locknuts (423) in the bearing housing (134) and tighten by hand.

6.6.3 Assemble the frame

1. Support the frame assembly in a horizontal position.
2. Check the shaft-end play by moving the shaft forward and backward by hand, and note any indicator movement.
If the total indicator reading is greater than the values in this table, then disassemble the shaft and determine the cause.

Table 18: Shaft-end play

Use this table as a reference for shaft-end play values.

Frame	Double row bearing	Duplex bearing
	0.028 0.0011	0.018 0.0007
STi millimeters inches	0.048 0.0019	0.025 0.0010
	0.033 0.0013	0.023 0.0009
MTi millimeters inches	0.053 0.0021	0.030 0.0012

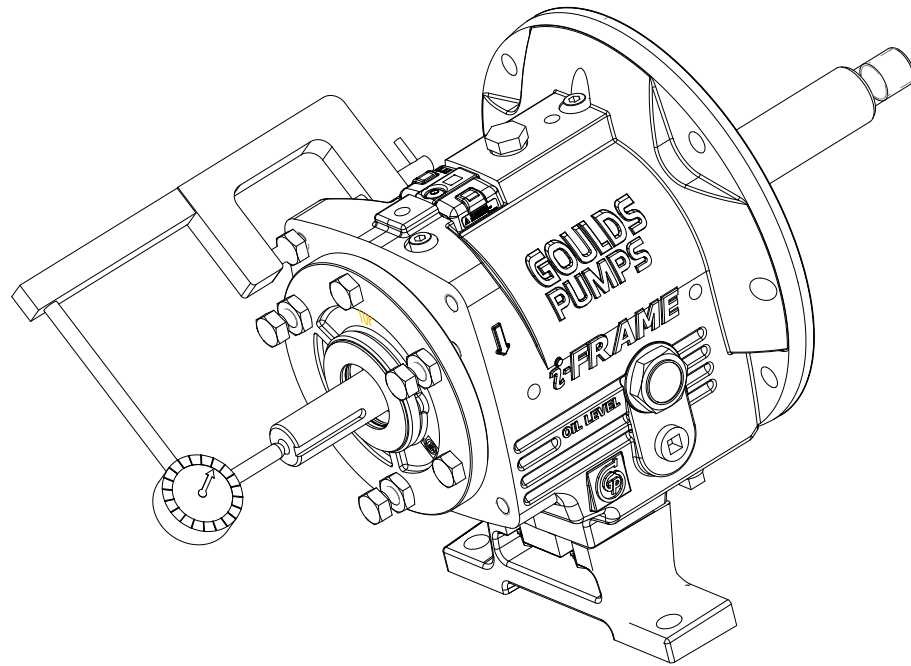

Figure 92: Check shaft end play

3. Check the shaft-sleeve (126) runout.
 - a) Install the shaft sleeve.
 - b) Thread the impeller on the shaft until hand tight.
 - c) Rotate the shaft 360°.
 - d) If the total indicator reading is greater than 0.051 mm | 0.002 in., then disassemble the shaft sleeve and determine the cause.
 - e) Remove the impeller and shaft sleeve.

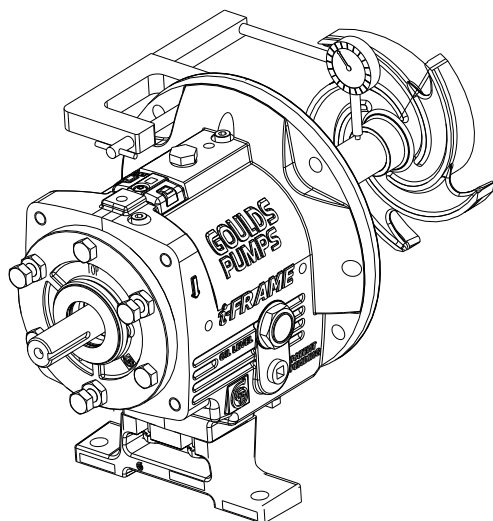

Figure 93: Remove impeller and shaft sleeve

4. Check the frame-face run-out by rotating the shaft so that the indicator measures the fit for 360°. If the total indicator reading is greater than 0.025 mm | 0.001 in., then disassemble and determine the cause.

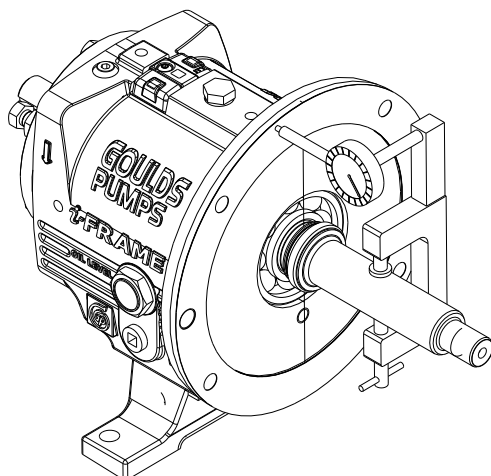

Figure 94: Check frame-face run-out

5. Place the manila gasket (360D) on the frame (228), and hold the gasket in place by inserting the dowel pins (469B) in their holes. The gasket is designed to fit only one way.
6. Install the frame adapter.
 - a) Place the frame adapter (108) onto the frame assembly.
 - b) Align the bolt holes and dowel locations on the frame adapter with the bolt holes and dowel locations on the frame.

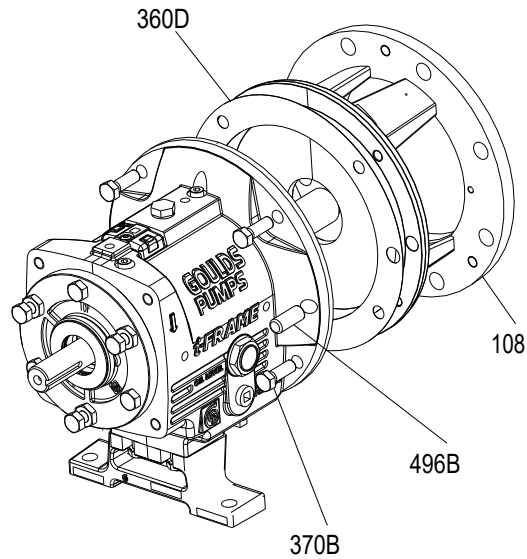

Figure 95: Align bolt holes and dowel locations

- c) Install the dowel pins (469B) and bolts (370B). Tighten the bolts in a criss-cross pattern according to the specifications in the bolt torque values table.
- d) Rotate the shaft 360° to check the adapter fit.
If the total indicator reading is greater than 0.13 mm | 0.005 in., then determine the cause and correct it before you proceed.

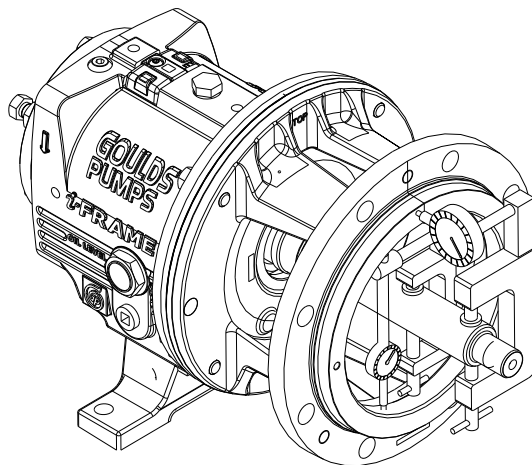

Figure 96: Check adapter fit

7. Install the labyrinth oil-seal (333A) into the adapter (108) and the bearing frame (228). The labyrinth oil seal is an O-ring fit.
8. Position the labyrinth oil-seal drain slots at the bottom (6 o'clock) position. Refer to Assemble the INPRO labyrinth oil-seal for more information on the labyrinth oil-seal installation.

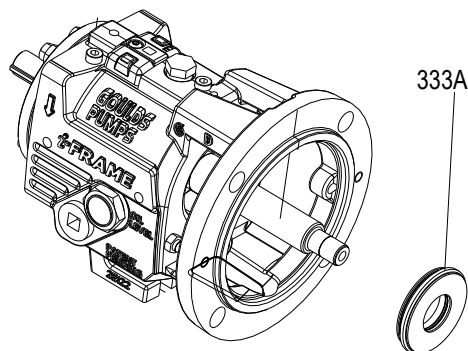

Figure 97: Position labyrinth oil-seal drain slots

6.6.4 INPRO labyrinth oil seal description

Description

The INPRO VBXX-D Labyrinth Oil Seal consists of the rotor (1), the stator (2), and the VBX Ring (3). The rotor (1) fits over the shaft and is held in place by an elastomeric drive ring (4). The drive ring causes the rotor to turn with the shaft and provides a positive, static seal against the shaft. Since there is no metal-to-metal contact, there are no friction or wear concerns.

NOTICE:

The labyrinth seal is a one-piece design. Do not attempt to separate the rotor from the stator. Doing so will damage the seal.

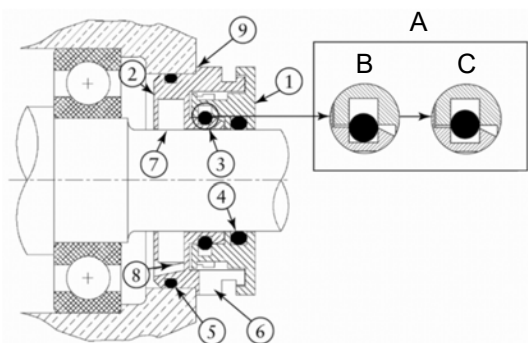

A	"VBX" O-ring action	4	Rotor drive ring
B	Static	5	Stator gasket
C	Dynamic	6	Expulsion port
1	Rotor	7	D groove
2	Stator	8	Lube return
3	"VBX" ring	9	Location shoulder

Figure 98: INPRO labyrinth oil seal

6.6.5 Assemble the INPRO labyrinth oil seal

1. Wrap electrical tape around the coupling end of the shaft to cover the keyway.

NOTICE:

The edges of the keyway can be sharp. Cover the keyway with tape. Failure to do so may result in damaging the o-ring and/or labyrinth seal.

2. Lightly lube the shaft and the drive ring (4) with lubricant. Lubricant helps in the installation process. Be sure that the lubricant is compatible with the O-ring material and the pump-system standards.
3. Use an arbor press to install the outboard INPRO VBXX-D into the bearing cover with the expulsion port (6) at the 6 o'clock position. Press the outboard INPRO VBXX-D down to where the stator location ramp (9) starts to avoid angular misalignment. There is a nominal 0.051 mm | 0.002 in. interference fit.
4. Discard any residual material from the stator gasket (5).
5. Complete the applicable step in this table depending on the model of your pump.

Pump model	Action
STi	Press the inboard seal along the shaft into the bearing frame.
All other models	After you install the frame adapter on the bearing frame, press the inboard seal over the shaft and into the adapter.

6.6.6 Assemble the C-face adapter

1. Mount the pump and the motor-coupling hubs if they are not already mounted.
2. Slide the C-face adapter over the pump shaft and mount it against the bearing-frame flange using four bolts.
3. Mount the motor to the C-face adapter using either four or eight motor bolts.

Table 19: Motor-bolt torque values for C-face adapter to frame

This table contains the motor-bolt torque values for assembling the C-face adapter to a frame.

Frame	Lubricated threads	Dry threads
STi	27 Nm 20 ft-lb	41 Nm 30 ft-lb
MTi	27 Nm 20 ft-lb	41 Nm 30 ft-lb

Table 20: Motor-bolt torque values for C-face adapter to motor

This table contains the motor-bolt torque values for assembling the C-face adapter to a motor.

Frame	Lubricated threads	Dry threads
143TC-145TC	11 Nm 8 ft-lb	16 Nm 12 ft-lb
182TC-286TC	20 ft-lb (27 Nm)	41 Nm 30 ft-lb
324TC-365TC	39 ft-lb (53 Nm)	80 Nm 59 ft-lb

6.6.7 Shaft sealing

**WARNING:**

The mechanical seal used in an Ex-classified environment must be properly certified.

**CAUTION:**

Running a mechanical seal dry, even for a few seconds, can cause seal failure and physical injury. Never operate the pump without liquid supplied to the mechanical seal.

Methods for sealing the shaft

These sections discuss the methods that you can use to seal the shaft.

- Seal the shaft with a cartridge-mechanical seal.
- Seal the shaft with a conventional inside-component mechanical seal.
- Seal the shaft with a conventional outside-component mechanical seal.
- Seal the shaft with a conventional inside-component double mechanical seal with FRP shaft sleeve.

6.6.7.1 Seal the shaft with a cartridge mechanical seal



WARNING:

The mechanical seal used in an Ex-classified environment must be properly certified.



CAUTION:

Running a mechanical seal dry, even for a few seconds, can cause seal failure and physical injury. Never operate the pump without liquid supplied to the mechanical seal.

1. Slide the cartridge seal onto the shaft or sleeve until it contacts the inboard labyrinth oil seal.
2. Assemble the seal chamber.
3. Slide the cartridge seal into the seal chamber and secure using the four studs and nuts.
4. Continue with the pump reassembly.
5. Set the impeller clearance.
Refer to the Impeller clearance setting topic for more information.
6. Tighten the setscrews in the seal locking ring in order to secure the seal to the shaft.
7. Remove the centering clips from the seal.

6.6.7.2 Seal the shaft with a conventional inside-component mechanical seal



WARNING:

The mechanical seal used in an Ex-classified environment must be properly certified.



CAUTION:

Running a mechanical seal dry, even for a few seconds, can cause seal failure and physical injury. Never operate the pump without liquid supplied to the mechanical seal.

1. Assemble the seal chamber:
 - a) Install a seal-chamber cover or a backplate (184) and fasten with nuts (370H).

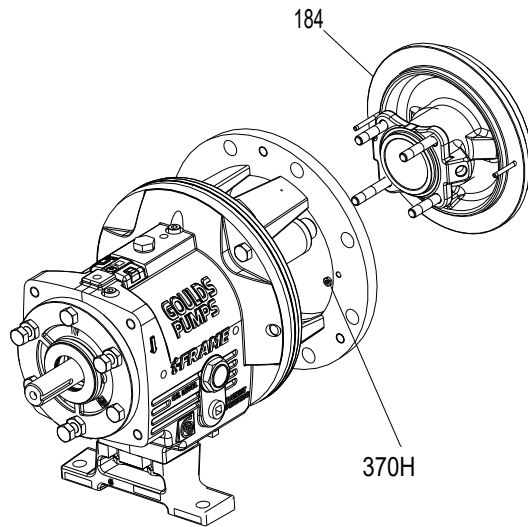

Figure 99: Assemble seal-chamber

- b) Check the seal-chamber cover runout.

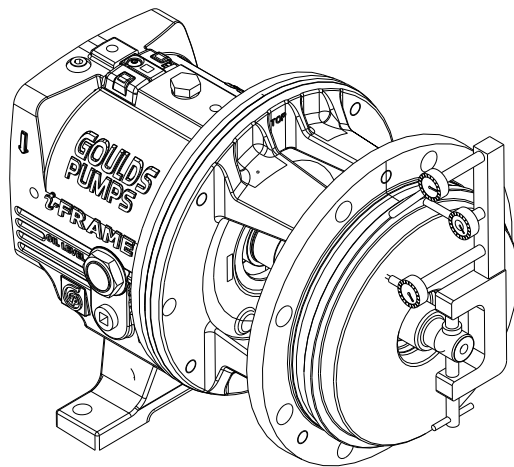

Figure 100: Check seal-chamber cover runout

Rotate the indicator through 360°. If the total indicator reading is greater than 0.13 mm | 0.005 inches, determine the cause and correct the issue before you proceed.

- c) Install the shaft sleeve (126).

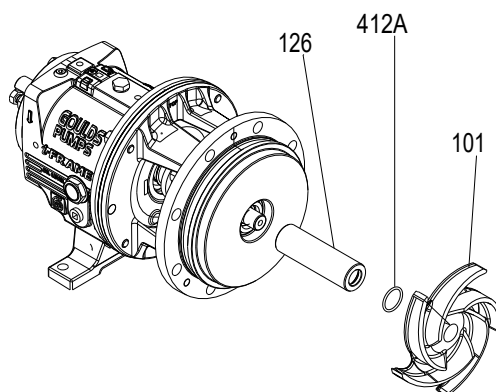

Figure 101: Install shaft sleeve

2. Mark the shaft and sleeve at the face of the seal chamber.
3. Continue the complete reassembly of the pump, except for the mechanical seal.
4. Set the impeller clearance.
Refer to the Impeller Clearance Setting section for more information.
5. Scribe a line on the marked shaft and sleeve at the face of the seal chamber.
6. Remove the casing, the impeller, and the seal chamber.
7. If applicable, slide the gland, with the stationary seat and gland gasket installed, onto the shaft until it contacts the inboard labyrinth oil seal.
8. Install the mechanical-seal rotary unit according to the manufacturer's instructions.
Use the scribed line and the seal-reference dimension.
9. Reinstall the seal chamber.
10. Slide the gland on the seal-chamber studs and secure them with the gland nuts.
Tighten the nuts evenly so that the gland is seated on the seal-chamber pilot and is perpendicular to the shaft.
11. Complete the reassembly of the pump.

6.6.7.3 Seal the shaft with a conventional outside-component mechanical seal



WARNING:

The mechanical seal used in an Ex-classified environment must be properly certified.



CAUTION:

Running a mechanical seal dry, even for a few seconds, can cause seal failure and physical injury. Never operate the pump without liquid supplied to the mechanical seal.

1. Assemble the seal chamber.
 - a) Install the seal-chamber cover or backplate (184) and fasten with nuts (370H).

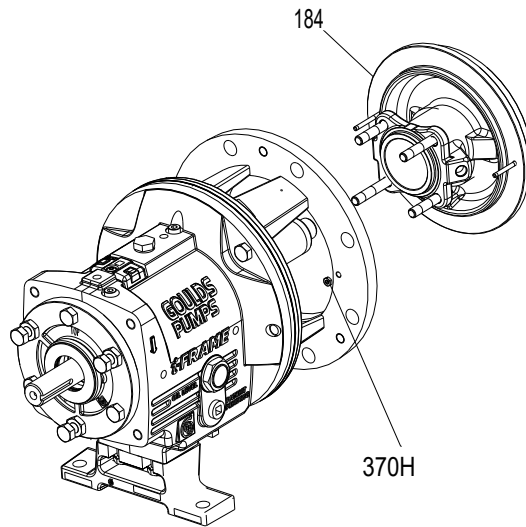

Figure 102: Seal-chamber cover or backplate installation

- b) Check the seal-chamber cover runout.

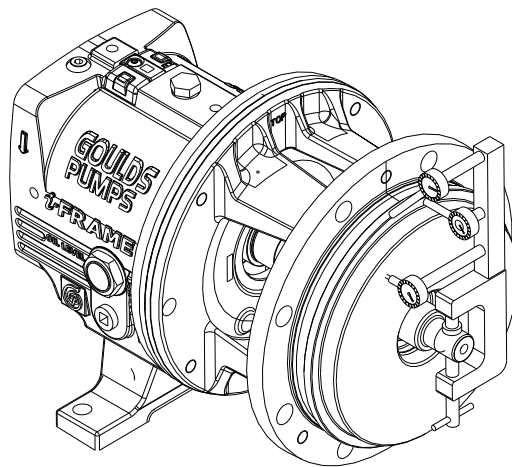

Figure 103: Check seal-chamber cover runout

Rotate the indicator through 360 degrees. If the total indicator reading is greater than 0.13 mm | 0.005 in., determine the cause and correct the issue before you proceed.

- c) Install the shaft sleeve (126).

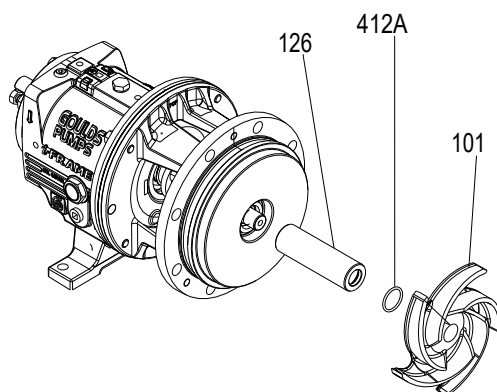

Figure 104: Install shaft sleeve

2. Mark the shaft and sleeve at the face of the seal chamber.
3. Continue the complete reassembly of the pump, except for the mechanical seal.
4. Set the impeller clearance.
Refer to the Impeller clearance setting section for more information.
5. Scribe a line on the marked shaft and sleeve at the face of the seal chamber.
6. Remove the casing, the impeller, and the seal chamber.
7. Install the mechanical-seal rotary unit per the manufacturer's instructions.
Use the scribed line as the seal-reference dimension. Be sure to secure the rotary unit in place using the set screws in the locking ring.
8. Install the gland, with the stationary seat and gland gaskets installed, on the seal chamber.
9. Reinstall the seal chamber.
10. Complete the reassembly of the pump.

6.6.7.4 Seal the shaft with a conventional inside-component double mechanical seal with FRP shaft sleeve



WARNING:

The mechanical seal used in an Ex-classified environment must be properly certified.



CAUTION:

Running a mechanical seal dry, even for a few seconds, can cause seal failure and physical injury. Never operate the pump without liquid supplied to the mechanical seal.

1. Pre-Assemble pump to check total travel and set front impeller clearance
 - a) Assemble the cover to the frame/frame adapter without the seal and gland. See [Figure 99: Assemble seal-chamber on page 114](#).
 - b) Check the seal-chamber cover runout. See [Figure 100: Check seal-chamber cover runout on page 114](#).
Rotate the indicator through 360°. If the total indicator reading is greater than 0.13 mm | 0.005 inches, determine the cause and correct the issue before you proceed.

- c) Assemble shaft sleeve, impeller, casing gasket and casing. (less mechanical seal). See [Figure 101: Install shaft sleeve on page 115](#).
 - d) Check Total Travel and set Impeller Front Clearance. Refer to the Impeller Clearance Setting section for more information.
 - e) Scribe a line to mark the location of the cover face onto the shaft sleeve. This will be your reference for setting the seals.
2. Installing the Mechanical Seal and Leak Testing
- a) Dis-assemble the casing, impeller, shaft sleeve and cover.
 - b) Lubricate the O-rings and install the stationary seals into the gland and cover taking care to protect the seal faces from any assembly tools. Clean the seal faces of any lubricant residue.
 - c) Measure and mark the setting locations for the rotary seals on the sleeve per the manufacturer's dimensions and instructions on the seal drawing.
 - d) Lubricate the O-rings and install the rotary seals on the shaft sleeve and position the seals per the setting dimension marks.
 - e) Adjust the two rotary seals so the setscrews are staggered 45 degrees from each other and thread the setscrews in so they just contact the sleeve.
 - f) Lightly tighten setscrews with T-Handle hex-drive using a 180 degree cross pattern. (Approx. 5 in-lbs.).
-

NOTICE:

If the setscrews are over torqued, the sleeve bore will distort making installation on the shaft difficult.

- g) After setting the rotary seals, clean the seal faces of any lubricant residue.
 - h) Place the gland onto the shaft and push back against the bearing frame.
 - i) Install the sleeve/seal assembly onto the Shaft and into the Gland.
-

NOTICE:

The sleeve should push onto the shaft with some difficulty but not with excessive force.

If it slips on easily, the setscrews are too loose.

If it requires excessive force, the setscrews are too tight. Make adjustments as necessary.

NOTICE:

The sleeve cannot be fully pushed onto the shaft due to the seal spring tension.

- j) Install the gland gasket onto the cover, install the cover, and tighten the gland studs.
 - k) Re-install the impeller.
-

NOTICE:

The impeller will move the shaft sleeve fully onto the shaft and set the seal spring tension for both seals.

- l) Conduct seal leak test (10 minutes at 25 psi).
 - m) Complete the reassembly of the pump.
-

6.6.8 Shaft guard installation (if provided)

6.6.8.1 Install the shaft guard (STi)



WARNING:

- Running a pump without safety devices exposes operators to risk of serious personal injury or death. Never operate a unit unless appropriate safety devices (guards, etc.) are properly installed.
- Failure to disconnect and lock out driver power may result in serious physical injury or death. Always disconnect and lock out power to the driver before performing any installation or maintenance tasks.
 - Electrical connections must be made by certified electricians in compliance with all international, national, state, and local rules.
 - Refer to driver/coupling/gear manufacturer's installation and operation manuals (IOM) for specific instructions and recommendations.

Exposed rotating shaft between pump seal and bearing frame. Avoid contact and/or install proper guarding. If guarding is not provided with the pump, contact Goulds for price and availability of proper guarding.

1. Ensure that the mounting bolt for each shaft guard half is inserted with the bolt retainer in place for captive hardware.
2. Assemble a guard half from each side of the pump and fasten to the bearing frame.
3. Ensure that adequate coverage is maintained for rotating components.

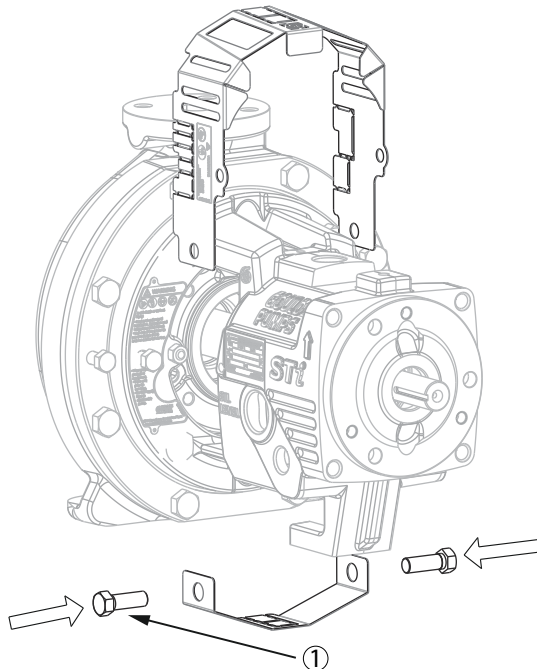

Figure 105: Shaft guard assembly

6.6.8.2 Install the shaft guard (MTi/LTi/XLTi/i17)



WARNING:

- Running a pump without safety devices exposes operators to risk of serious personal injury or death. Never operate a unit unless appropriate safety devices (guards, etc.) are properly installed.
- Failure to disconnect and lock out driver power may result in serious physical injury or death. Always disconnect and lock out power to the driver before performing any installation or maintenance tasks.
 - Electrical connections must be made by certified electricians in compliance with all international, national, state, and local rules.
 - Refer to driver/coupling/gear manufacturer's installation and operation manuals (IOM) for specific instructions and recommendations.

1. Ensure that the mounting bolt for each shaft guard half is inserted with the bolt retainer in place for captive hardware.
2. If brackets were removed during disassembly, attach brackets to the frame adapter on each side of the pump.
3. Assemble a guard half from each side of the pump and fasten to the bracket connection.
4. Ensure that adequate coverage is maintained for rotating components.

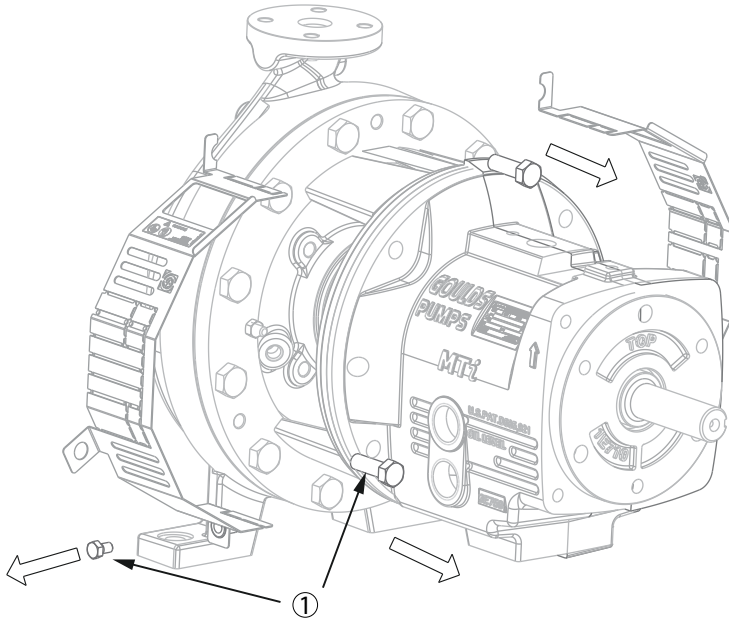

Item	Description
1.	Mounting bolt

Figure 106: Shaft guard assembly

6.6.9 Install the impeller



CAUTION:

Risk of physical injury from sharp edges. Wear heavy work gloves when handling impellers.

1. Install the impeller.

Pump size	Action
STi, MTi	Install the impeller (101). Use a new impeller O-ring (412A).

2. Attach a shaft wrench and a coupling key on the shaft.
 - a) When the impeller (101) makes firm contact with the sleeve (126), raise the shaft wrench (counterclockwise, viewed from the impeller end of the shaft) off of the bench and slam it down (clockwise, viewed from the impeller end of shaft).
 - b) Apply a few sharp raps to tighten the impeller (101).

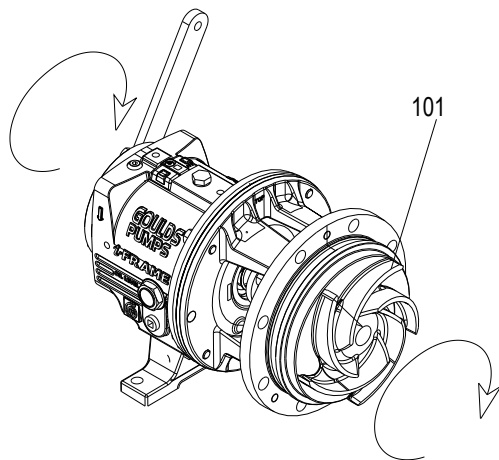

Figure 107: Tighten the impeller

3. Loosen the clamp bolts (370C) and the jack bolts (370D).
4. Measure the gap between the impeller (101) and the seal chamber and stuffing-box cover (184) with a feeler gauge.

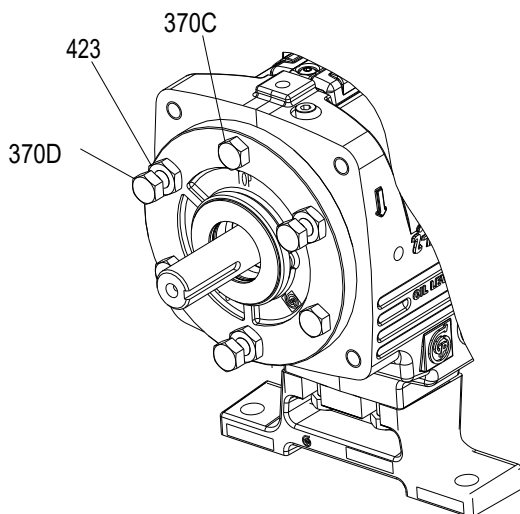

Figure 108: Loosen clamp bolts

5. When you reach a 0.76 mm | 0.030 in. clearance, tighten the clamp bolts (370C), jack bolts (370D), and lock nuts (423).

This approximates the impeller position when it is set to 0.38 mm | 0.015 in. from the casing. Perform a final impeller adjustment after you install the impeller into the casing.

6. Check the impeller (101) runout.

Check vane tip to vane tip. If the total indicator reading is greater than 0.13 mm | 0.005 in., determine the cause and correct the issue before you proceed.

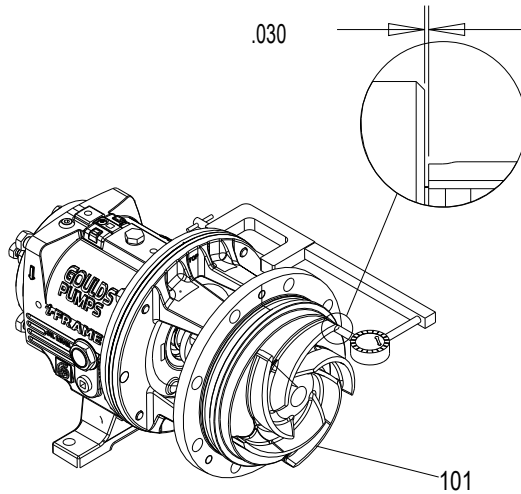

Figure 109: Check impeller run out

For more information on how to set the impeller clearances, refer to the Impeller-clearance checks and Impeller-clearance setting sections in Commissioning, Startup, Operation, and Shutdown.

6.6.10 Post-assembly checks

Perform these checks after you assemble the pump, then continue with pump startup:

- Rotate the shaft by hand in order to make sure that it rotates easily and smoothly and that there is no rubbing.
- Open the isolation valves and check the pump for leaks.

6.6.11 Install the back pull-out assembly (except HT 3196)



WARNING:

Lifting and handling heavy equipment poses a crush hazard. Use caution during lifting and handling and wear appropriate Personal Protective Equipment (PPE, such as steel-toed shoes, gloves, etc.) at all times. Seek assistance if necessary.

1. Clean the casing fit and install the casing gasket (351) on the seal chamber and stuffing-box cover.
2. Loosen the clamping bolts (370C) and jack bolts (370D) on the bearing housing.

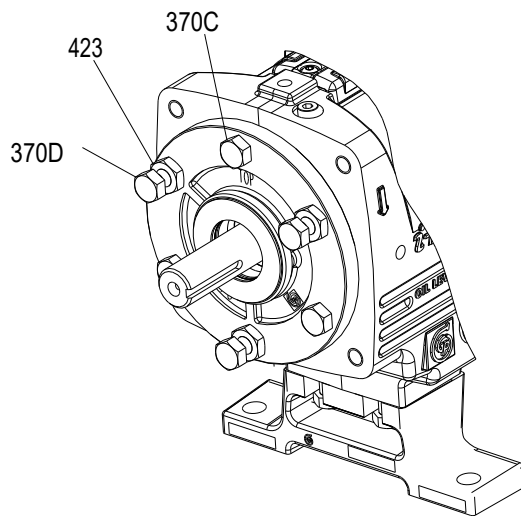

Figure 110: Loosen clamp bolts and jack bolts on bearing housing

3. Install the back pull-out assembly in the casing.

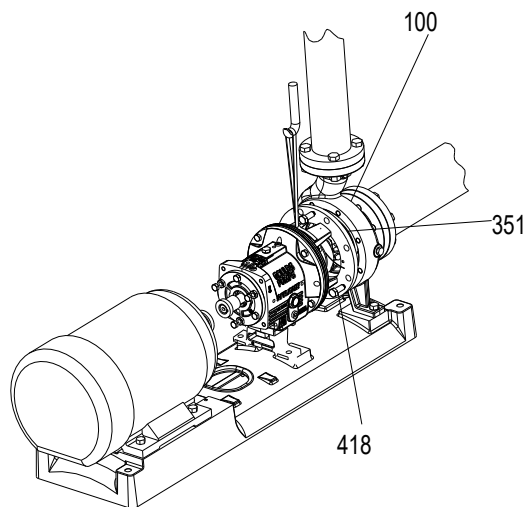

Figure 111: Install back pull-out assembly

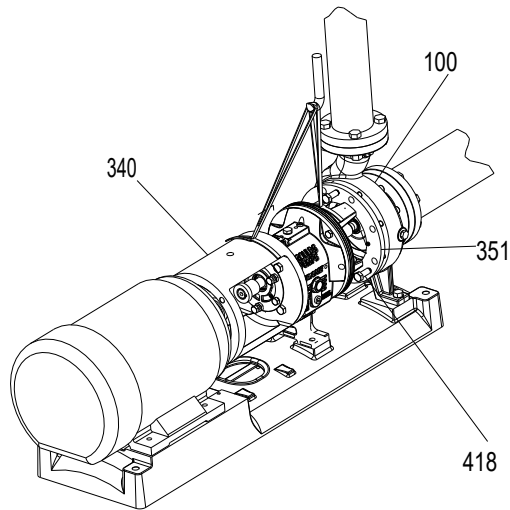

Figure 112: Install back pull-out assembly

4. Install and then hand-tighten the casing bolts (370). Refer to the bolt torque values for information on how to tighten the casing bolts.
5. Install and tighten the casing jackscrews (418).

NOTICE:

Do not overtighten the casing jackscrews. Doing so may result in equipment damage.

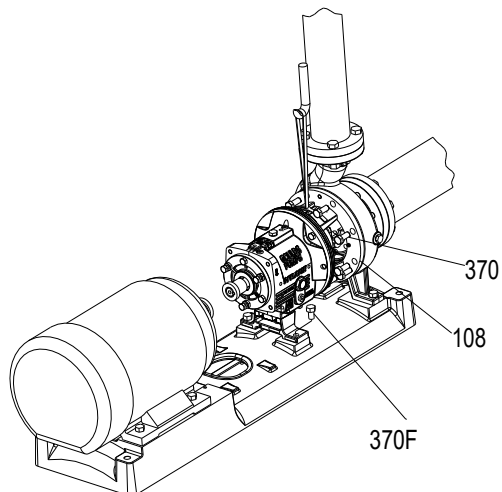

Figure 113: Install and tighten casing jackscrews

6. Reinstall the shims under the frame foot and tighten the frame foot to the baseplate. Make sure that you use the proper shim. Mount a dial indicator in order to measure the distance between the top of the frame and the baseplate. Make sure that the distance does not change as you tighten the frame-foot bolts.
7. Check the total clearance of the impeller in the casing. With new parts, an acceptable range is (refer to table below) If the impeller clearance is outside of this range, you either have the incorrect parts, an improper installation, or too much pipe strain. Determine the cause and correct the problem before you proceed.

Frame	Total travel
STi, MTi, LTi	0.76 mm to 1.65 mm 0.030 in. to 0.065 in.
4x6-10H only	1.53 mm to 2.29 mm 0.060 in. to 0.090 in.
XLTi, i-17	1.02 mm to 2.67 mm 0.040 in. to 0.105 in.

8. Adjust the impeller clearance.
Refer to the Impeller clearance setting section for more information.
9. Replace the auxiliary piping.
10. Fill the pump with the proper lubricant. See Lubricating-oil requirements.
11. Reinstall the coupling guard.
See Install the coupling guard for more information.

NOTICE:

When a cartridge mechanical seal is used, ensure that the set screws in the seal locking ring are tightened and that the centering clips have been removed prior to startup. This prevents seal or shaft sleeve damage by ensuring that the seal is properly installed and centered on the sleeve.

6.6.12 Assembly references

6.6.12.1 Bolt torque values

Table 21: Bolt torque, Nm | lb-ft

This table provides the bolt torque values.

Location	Bolt Material	Frame	3196, CV3196, LF3196, HT3196, 3796		NM 3196		3198	
			Lube	Dry	Lube	Dry	Lube	Dry
Casing bolts (370) or casing nuts (425)	see casing bolt table	6-in. STi	Refer to the max torque values in Nm lb-ft for casing bolts table		36 27	53 40	Refer to the max torque values (Nm lb-ft) for casing bolts table.	
		8-in. STi			27 20	40 30		
		MTi, LTi			36 27	53 40		
		XLT-i, i17			N/A	N/A		
Frame-to-adapter bolts (370B)	Goulds 2210	All	29 22	40 30	29 22	40 30	29 22	40 30
Frame-to-adapter bolts (370B)	Goulds 2228	All	54 40	73 54	54 40	73 54	54 40	73 54
Bearing-clamp ring bolts (236A) - duplex bearing only	Goulds 2210	STi, MTi	1.1 10*	1.9 17*	1.1 10*	1.9 17*	1.1 10*	1.9 17*
		LTi	6.7 60*	9.3 83*	6.7 60*	9.3 83*	6.7 60*	9.3 83*
Bearing end cover bolts (371C)	Goulds 2210	XLT-i, i17	12 9	16 12	N/A	N/A	N/A	N/A
Dynamic seal cap-screws (265)	Goulds 2228	MTi, LTi	12 9	16 12	N/A	N/A	N/A	N/A
		XLT-i, i17	23 17	29 22	N/A	N/A	N/A	N/A

* Values are in Nm | lb-in.

6.6.12.2 Shaft-end play

Table 22: Shaft-end play

Use this table as a reference for shaft-end play values.

Frame	Double row bearing	Duplex bearing
	0.028 0.0011	0.018 0.0007
STi millimeters inches	0.048 0.0019	0.025 0.0010
	0.033 0.0013	0.023 0.0009
MTi millimeters inches	0.053 0.0021	0.030 0.0012

6.6.12.3 Bearing types

Table 23: Bearing types

Frame	Inboard bearing	Outboard bearing	
		Double row	Duplex
STi	6207	3306	7306
MTi	6309	3309	7309



















6.6.13 Spare parts

Always state the serial number and indicate the part name and item number from the relevant sectional drawing when you order spare parts. It is imperative for service reliability to have a sufficient stock of readily available spare parts.

- Impeller (101)
- Shaft (122A)
- Shaft sleeve (126)
- Outboard bearing (112A)
- Inboard bearing (168A)
- Casing gasket (351)
- Frame-to-adapter gasket (360D)
- Bearing-housing retaining ring (361A)
- Bearing lockwasher (382)
- Bearing locknut (136)
- Impeller O-ring (412A)
- Bearing-housing O-ring (496)
- Outboard labyrinth-seal rotary O-ring (497F)
- Outboard labyrinth-seal stationary O-ring (497G)
- Inboard labyrinth-seal rotary O-ring (497H)
- Inboard labyrinth-seal stationary O-ring (497J)
- Lantern ring half (105) (packed stuffing box)
- Stuffing box packing (106) (packed stuffing box)
- Packing gland (107) (packed stuffing box)
- Impeller gasket (428D) (XLT-i and i17 only)

6.7 Interchangeability drawings

6.7.1 NM 3196 interchangeability

Description	Shaft and Bearing Frame Assembly	Adapter	Seal Chamber	Impeller	Casing	Size
Model NM 3196 STi 1-3/8 in. Shaft Dia. Max BHP-40 HP						1x1.5-6 AA
						1.5x3-6 AB
						2x3-6 AC
						1x1.5-8 AA
						1.5x3-8 AB
Model NM 3196 MTi 1-3/4 in. Shaft Dia. Max BHP-122 HP						3x4-8G A70
						1x2-10 A05
						2x3-10 A60
						3x4-10H A40
						4x6-10H A80
						1.5x3-13 A20
						3x4-13 A40
						4x6-13 A80

6.8 Lubrication conversion

6.8.1 Frame lubrication conversion

NOTICE:

- Avoid equipment damage or decreased performance. Never mix greases of different consistencies (NLGI 1 or 3 with NLGI 2) or with different thickeners. For example, never mix a lithium-based grease with a polyurea based grease. If it is necessary to change the grease type or consistency, remove the rotor and old grease from the housing before re-greasing.

Use a grease that is suitable for high temperatures when you have frame pumpage temperatures greater than 177°C | 350°F. Ensure that mineral-oil greases have oxidation stabilizers and a consistency of NLGI 3.

Table 24: Lubricating-grease requirements

Most pumps use Sunoco 2EP grease. High temperature units with a pumpage temperature greater than 177°C | 350° F use Mobil SCH32.

This table shows which brand of grease to use when lubricating the pump.

	Pumpage temperature less than 177°C 350°F	Pumpage temperature greater than 177°C 350°F
NGLI consistency	2	3
Mobil	Mobilux EP2	SCH32
Exxon	Unirex N2	Unirex N3
Sunoco	Mutipurpose 2EP	N/A
SKF	LGMT 2	LGMT 3

6.8.2 Convert from greased-for-life or regreaseable to oil-lubricated bearings

1. Remove the plug from the oil-return slot in the frame located under the radial bearing. Use this table as a guide.

Pump model	Action
STi	Remove the epoxy from the return slot.
MTi	Remove the set screw installed in the oil-return hole.

2. Remove the plug from the oil-return hole in the bearing housing (134).
3. Replace both bearings with unshielded, oil-lubricated bearings.

Table 25: Bearing types

Frame	Inboard bearing	Outboard bearing	
		Double row	Duplex
STi	6207	3306	7306
MTi	6309	3309	7309

4. Remove the grease fittings (193) to prevent accidental greasing. Two plugs (408H) are required to replace the two grease fittings.

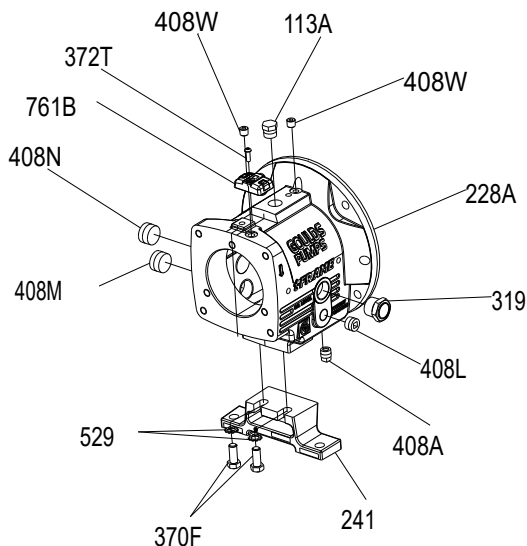

Figure 114: Replace two grease fittings with two plugs

Item Number	Size	Description	Quantity
113	1/4"-18 NPT	External hex/square head pipe plug	2
113A	1/2"-14 NPT	External hex/square head pipe plug	1
193	1/4"-18 NPT	Grease fitting	2
228	- - - -	Bearing frame	1
241	- - - -	Frame foot	1
370F	1/2"	Hex cap screw	2
408A	3/8"-18 NPT	External square head pipe plug (magnetic)	1
408J	1/4"-18 NPT	External hex/square head pipe plug	1
408L	1/2"-14 NPT	Square countersunk headless pipe plug	1
408M	1" 11-1/2" NPT	Square countersunk headless pipe plug	1
529	1/2"	Light helical spring lock washer	2

6.8.3 Conversion from flood-oil to pure-oil mist

NOTICE:

The LTX requires that you change the bearing housing when you make the conversion from flood oil to oil mist lubrication. After you install the proper bearing housing, follow the instructions as they apply to STX, MTX, XLT-X, and X17. Failure to do so may result in equipment damage or decreased performance.

NOTICE:

Ensure that the pipe threads are clean. Apply thread sealant to the plugs and fittings. Failure to do so may result in oil leaks and equipment damage.

Consult your local ITT representative for further information on this topic.

6.8.3.1 Oil mist systems

If the bearing frame has been purchased with oil lubrication and provisions for pure oil mist, then all frames can be modified for pure oil mist by replacing the plugs (408H) in the bearing frame and installing oil mist connections as noted in Figure below.

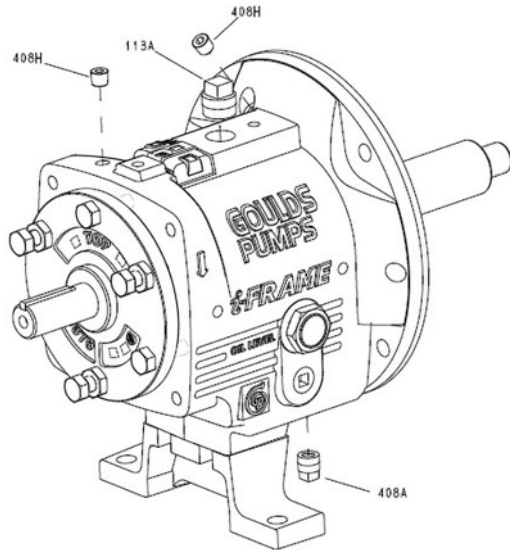

Figure 115: Replace two plugs (408H) with two to oil mist connectors

Oil-mist systems

The ITT X i-Series Power Ends accepts a variety of oil-mist systems. These are the two popular systems that you can use:

- vented oil-mist system
- non-vented oil-mist system

6.8.4 Convert from flood oil to regreaseable

NOTICE:

Ensure that the pipe threads are clean. Apply thread sealant to the plugs and fittings. Failure to do so may result in oil leaks and equipment damage.

Consult your local ITT representative for further information on this topic.

7 Troubleshooting

7.1 Operation troubleshooting

Symptom	Cause	Remedy
The pump is not delivering liquid.	The pump is not primed.	Re-prime the pump and check that the pump and suction line are full of liquid.
	The suction line is clogged.	Remove the obstructions.
	The impeller is clogged.	Back-flush the pump in order to clean the impeller.
	The shaft is rotating in the wrong direction.	Change the rotation. The rotation must match the arrow on the bearing housing or pump casing.
	The foot valve or suction pipe opening is not submerged enough.	Consult an ITT representative for the proper submersion depth. Use a baffle in order to eliminate vortices.
	The suction lift is too high.	Shorten the suction pipe.
The pump is not producing the rated flow or head.	The gasket or O-ring has an air leak.	Replace the gasket or O-ring.
	The stuffing box has an air leak.	Replace or readjust the mechanical seal.
	The impeller is partly clogged.	Back-flush the pump in order to clean the impeller.
	The clearance between the impeller and the pump casing is excessive.	Adjust the impeller clearance.
	The suction head is not sufficient.	Make sure that the suction-line shutoff valve is fully open and that the line is unobstructed.
	The impeller is worn or broken.	Inspect and replace the impeller if necessary.
The pump starts and then stops pumping.	The pump is not primed.	Re-prime the pump and check that the pump and suction line are full of liquid.
	The suction line has air or vapor pockets.	Rearrange the piping in order to eliminate air pockets.
	The suction line has an air leak.	Repair the leak.
The bearings are running hot.	The pump and driver are not aligned properly.	Realign the pump and driver.
	There is not sufficient lubrication.	Check the lubricant for suitability and level.
	The lubrication was not cooled properly.	Check the cooling system.
The pump is noisy or vibrates.	The pump and driver are not aligned properly.	Realign the pump and driver.
	The impeller is partly clogged.	Back-flush the pump in order to clean the impeller.
	The impeller or shaft is broken or bent.	Replace the impeller or shaft as necessary.
	The foundation is not rigid.	Tighten the hold-down bolts of the pump and motor. Make sure the baseplate is properly grouted without voids or air pockets.
	The bearings are worn.	Replace the bearings.
	The suction or discharge piping is not anchored or properly supported.	Anchor the suction or discharge piping as necessary according to recommendations in the Hydraulic Institute Standards Manual.
	The pump is cavitating.	Locate and correct the system problem.
The mechanical seal is leaking excessively.	The packing gland is not adjusted properly.	Tighten the gland nuts.

7.2 Alignment troubleshooting

Symptom	Cause	Remedy
	The stuffing box is not packed properly.	Check the packing and repack the box.
	The mechanical seal parts are worn.	Replace the worn parts.
	The mechanical seal is overheating.	Check the lubrication and cooling lines.
	The shaft or shaft sleeve is scored.	Machine or replace the shaft sleeve as necessary.
The motor requires excessive power.	The discharge head has dropped below the rated point and is pumping too much liquid.	Install a throttle valve. If this does not help, then trim the impeller diameter. If this does not help, then contact your ITT representative.
	The liquid is heavier than expected.	Check the specific gravity and viscosity.
	The stuffing-box packing is too tight.	Readjust the packing. If the packing is worn, then replace the packing.
	Rotating parts are rubbing against each other.	Check the parts that are wearing for proper clearances.
	The impeller clearance is too tight.	Adjust the impeller clearance.

7.2 Alignment troubleshooting

Symptom	Cause	Remedy
Horizontal (side-to-side) alignment cannot be obtained (angular or parallel).	The driver feet are bolt-bound.	Loosen the pump's hold-down bolts, and slide the pump and driver until you achieve horizontal alignment.
	The baseplate is not leveled properly and is probably twisted.	<ol style="list-style-type: none"> Determine which corners of the baseplate are high or low. Remove or add shims at the appropriate corners. Realign the pump and driver.

7.3 Assembly troubleshooting

Symptom	Cause	Remedy
There is excessive shaft end play.	The internal clearance of the bearings exceeds the recommended amount.	Replace the bearings with a bearing of the correct type.
	The snap ring is loose in the bearing-housing groove.	Re-seat the snap ring.
There is excessive shaft and sleeve runout.	The sleeve is worn.	Replace the sleeve.
	The shaft is bent.	Replace the shaft.
There is excessive bearing-frame flange runout.	The shaft is bent.	Replace the shaft.
	The flange of the bearing frame is distorted.	Replace the bearing-frame flange.
There is excessive frame-adapter runout.	There is corrosion on the frame adapter.	Replace the frame adapter.
	The adapter-to-frame gasket is not seated properly.	Re-seat the frame adapter and make sure that the adapter-to-frame gasket is seated properly.
There is excessive seal chamber or stuffing-box cover runout.	The seal chamber or the stuffing-box cover is not properly seated in the frame adapter.	Re-seat the seal chamber or stuffing-box cover.
	There is corrosion or wear on the seal chamber or stuffing-box cover.	Replace the seal chamber or stuffing-box cover.

Symptom	Cause	Remedy
There is excessive vane-tip runout of the impeller.	The vane is bent.	Replace the impeller.

8 Parts List and Cross-Sectionals

8.1 Parts list

Table 26: Construction material and quantity

Item	Qty	Part name	Pump Material
			Fiberglass Reinforced Vinylester
100	1	Casing	6929
101	1	Impeller (with insert)	6929 (Insert - 1215)
108	1	Frame Adapter	1013
112	1	Outboard Bearing	Double row angular contact
113	2	Plug - Grease Relief	2210
113A	1	Plug - Oil Fill	2210
122	1	Shaft - without Sleeve	2229
122	1	Shaft - with Sleeve	2238
126	1	Shaft Sleeve - FRP (Standard)	6422
126	1	Shaft Sleeve - Metal (Optional)	2229, 2230, 2247, 2248, 2156, or 2157
134	1	Bearing Housing	1001
136	1	Bearing Locknut	Steel
159	1	Seal Chamber	6929
168	1	Inboard Bearing	Single row ball
193	2	Grease Fitting	Steel
228A	1	Bearing Frame	STi - 1013, All others - 1003
236A	10	Cap Screw - Bearing Clamp Ring	2210
241	1	Frame Foot	1001
250	1	Gland - Mechanical Seal	6929
253B	1	Bearing Clamp Ring	2210
319	1	Sight Glass	Glass / steel
332A	1	INPRO® VBXX-D Labyrinth Oil Seal (Outboard)	Stator - bronze / Rotor - stainless steel
333A	1	INPRO® VBXX-D Labyrinth Oil Seal (Inboard)	Stator - bronze / Rotor - stainless steel
353	4	Gland Stud	2228
355	4	Gland Stud Nut	2228
356A	*	Stud - Adapter to Case	2228
357L	2	Hex Nut-Backplate to Adapter	2228
358	1	Plug-Casing Drain	PTFE
360D	1	Gasket-Frame to Adapter	Buna N
360Q	1	Gasket-Gland to Backplate	Viton
361A	1	Retaining Ring	Steel
370B	4	Bolt-Frame-to-Adapter	2228
370C	3	Clamp Bolt-Bearing Housing	2228
370D	3	Jack Bolt-Bearing Housing	2228
370F	2	Bolt-Frame Foot to Frame	2228
370H	2	Stud-Backplate-to-Adapter	2228
372T	1	Screw - i-ALERT® Monitor	18-8 Stainless Steel
382	1	Bearing Lockwasher	Steel

Item	Qty	Part name	Pump Material
			Fiberglass Reinforced Vinylester
383	1	Mechanical Seal	Material Varies
400	1	Key-Coupling	Steel
408A	1	Plug-Oil Drain	2210
408H	4	Plug-Oil Mist Connection	2210
408J	1	Plug-Oiler	2210
408L	1	Plug-Oil Cooler Inlet	2210
408M	1	Plug-Oil Cooler Outlet	2210
408N	1	Plug-Sight Glass	2210
412A	1	O-ring-Impeller	Viton
412V	1	O-ring-Backplate	Viton
418	3	Jack Bolt-Adapter to Case	2228
423B	3	Jam Nut-Bearing Housing Jack Bolt	2228
356A	*	Hex Nut-Adapter-to-Case	2228
444	1	Backplate	6929
469B	2	Dowel Pin - Frame to Adapter	Steel
494	1	Tubing, Finned Cooling Assembly	Tubing 304SS / Fins - Copper
496	1	O-Ring Bearing Housing	Buna N
497F	1	O-Ring - Outboard Labyrinth Rotor	Viton
497G	1	O-Ring - Outboard Labyrinth Stator	Buna N
497H	1	O-Ring - Inboard Labyrinth Rotor	Viton
497J	1	O-Ring - Inboard Labyrinth Stator	Buna N
503	1	Adapter Ring (8" STi only)	1013
528A	2	Lockwasher - Frame Foot to Frame	2228
555B	2	Connector, Thermocouple (Frame Cooling)	Brass
555C	2	Elbow, Female (Frame Cooling)	Brass
555D	1	Hex Bushing (Frame Cooling)	Cast iron
761B	1	i-ALERT® Condition Monitor	Nylon / Epoxy

Chart Key	
*	Qty 4 for 6" ST1 Qty 8 for 8" STi and MTi Qty 12 for 10" MTi Qty 16 for 13" MTi

Table 27: Material-code reference

Material	Goolds material code	ASTM (UNS)	DIN	ISO	JIS
Cast Iron	1001	A48 Class 20			
Cast Iron	1003	A48 Class 30			
Ductile Iron	1013	A536 Gr. 60-42-10			
Hastelloy C	1215	A494 Gr. CW2M (N26455)			
Titanium	2156	B348 Gr. 2 (R50400)			
Zirconium	2157	B550 Gr. 702 (R60702)			

8.1 Parts list

Material	Goulds material code	ASTM (UNS)	DIN	ISO	JIS
Carbon Steel	2210	A108 Gr. 1018 (G10180)			
304SS	2228	A276 Type 304 (S30400)			
316SS	2229	A276 Type 316 (S31600)			
Alloy 20	2230	B473 (N08020)			
4140 Steel	2238	A434 Gr. 4140 (G41400) Cl. BC			
Alloy B-2	2247	B335 (N10665)			
Alloy C-276	2248	B574 (N10276)			
Fiberglass Reinforced Vinylyester	6422	N/A			
Fiberglass Reinforced Vinylyester	6929	N/A			

Fasteners			
Material	Goulds Pumps Material Code	ASTM	
		Screws / Bolts	Nuts
Carbon Steel	2210	A307 Gr. B	A563 Gr. A
300 Series Stainless Steel	2228	F593 Group 1	F594 Group 1
316 Stainless Steel	2229	F593 Group 2	F594 Group 2

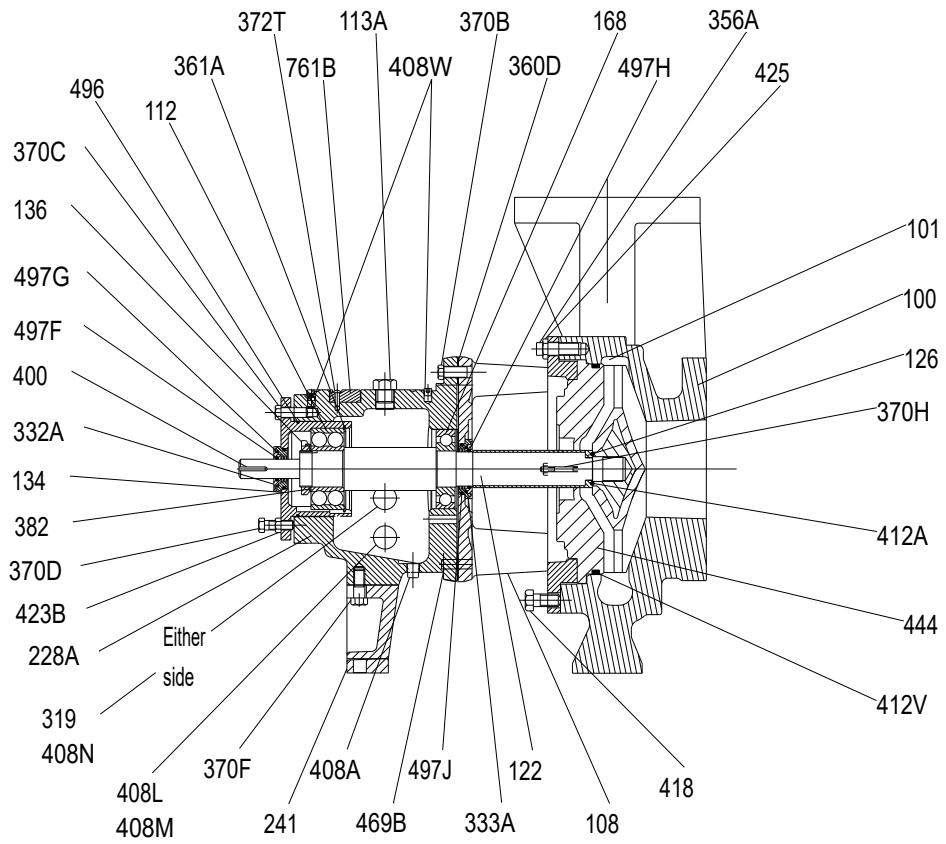

Figure 116: NM 3196 cross-sectional drawing

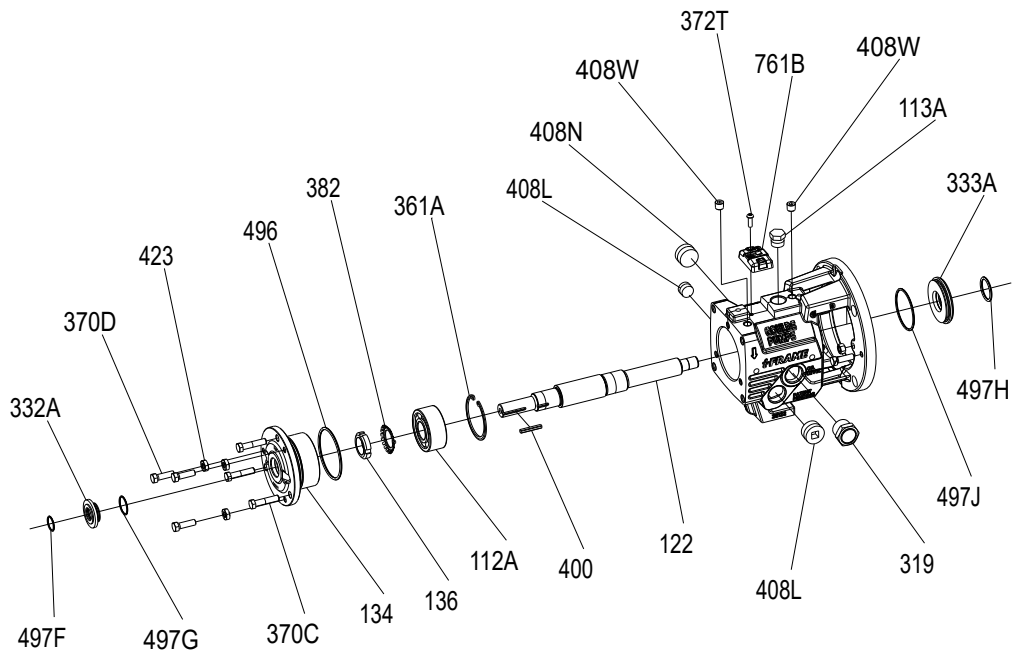

Figure 117: STi bearing-frame exploded view

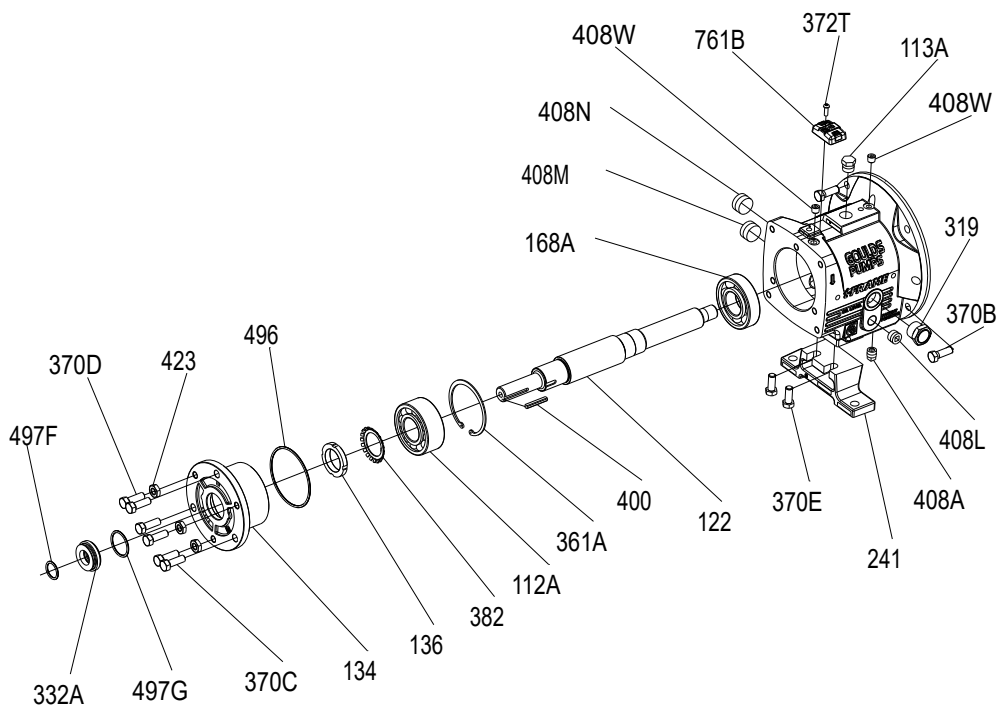

Figure 118: MTi bearing-frame exploded view

The finned-tube oil cooler is standard on HT 3196 and optional on all other models.

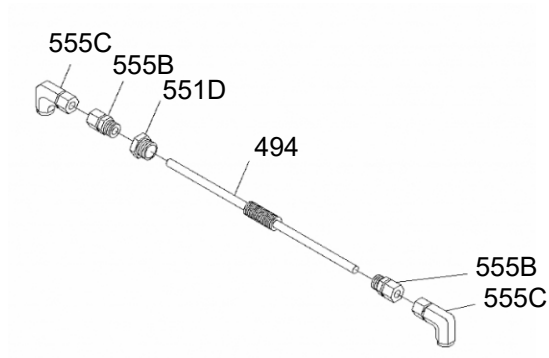

Figure 119: Finned-tube oil cooler exploded view

9 Other Relevant Documentation or Manuals

9.1 For additional documentation

For any other relevant documentation or manuals, contact your ITT representative.

10 Local ITT Contacts

10.1 Regional offices

Region	Address	Telephone	Fax
North America (Headquarters)	ITT - Goulds Pumps 240 Fall Street Seneca Falls, NY 13148 USA	+1 315-568-2811	+1 315-568-2418
Houston office	12510 Sugar Ridge Boulevard Stafford, TX 77477 USA	+1 281-504-6300	+1 281-504-6399
Los Angeles	ITT - Goulds Pumps 880 W. Crowther Ave Placentia, CA 92870 USA	+1 562-908-4125	+1 562-695-8523
Asia Pacific	ITT Fluid Technology Asia Pte Ltd 1 Jalan Kilang Timor #04-06 Singapore 159303	+65 627-63693	+65 627-63685
Asia Pacific	ITT Goulds Pumps Ltd 35, Oksansandan-ro Oksan-myeon, Heungdeok-gu, Cheongju-si, Chungcheongbuk-do 28101, Rep. of KOREA	+82 234444202	
Europe	ITT Bornemann GmbH Industriestrasse 2, 31683 Obern- kirchen, Germany	+49 5724 390 2340	+49 5724 390 290
Latin America	ITT - Goulds Pumps Camino La Colina # 1448 Condominio Industrial El Rosal Huechuraba Santiago 8580000 Chile	+562 544-7000	+562 544-7001
Middle East and Africa	ITT - Goulds Pumps Achileos Kyrou 4 Neo Psychiko 115 25 Athens Greece	+30 210-677-0770	+30 210-677-5642

**Visit our website for the latest version of
this document and more information:**
<http://www.gouldspumps.com>



ITT Goulds Pumps, Inc.
240 Fall Street
Seneca Falls, NY 13148
USA

Form IOM.NM3196.i-FRAME.en-US.2023-10

©2023 ITT Inc.
The original instruction is in English. All non-English instructions are translations of the original instruction.