

GOULDS PUMPS

Installation, Operation and Maintenance Instructions

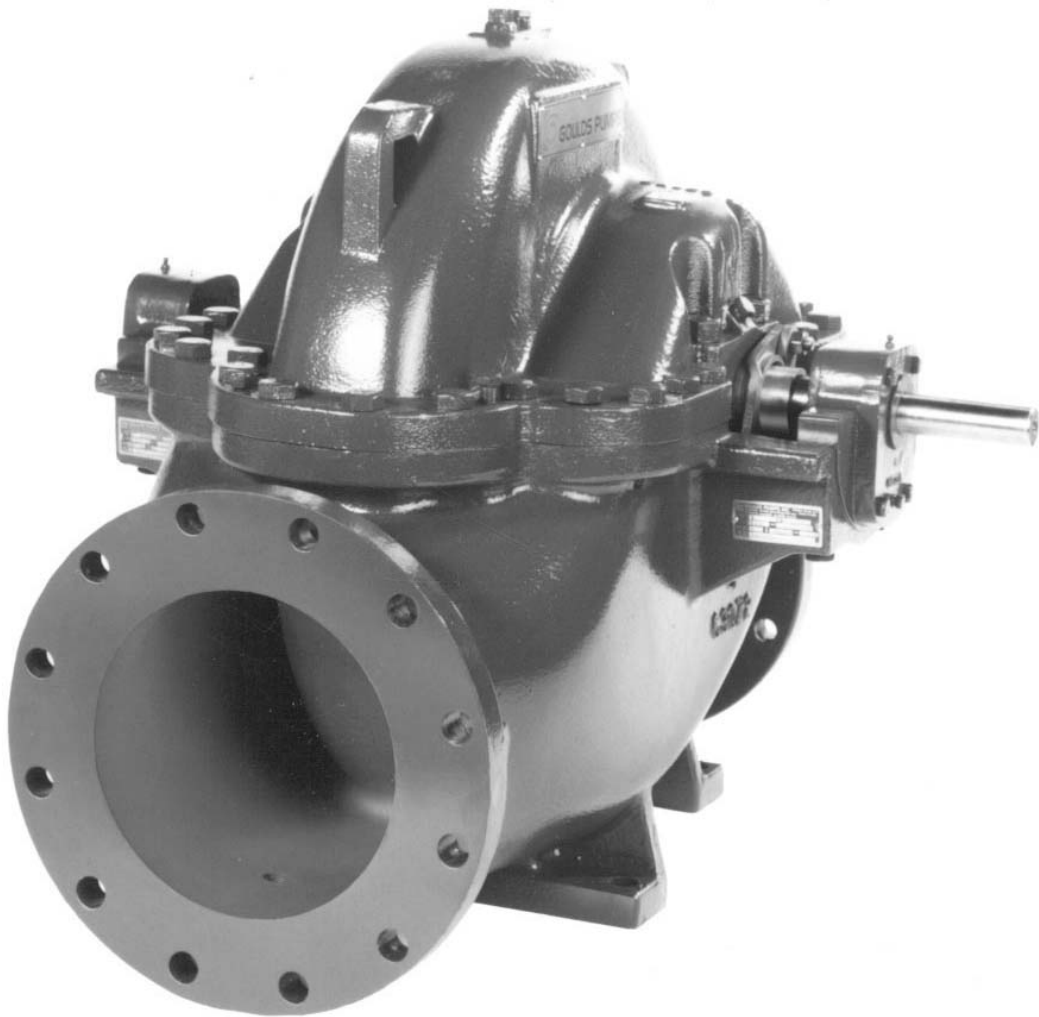

Model 3410

FOREWORD

This manual provides instructions for the Installation, Operation, and Maintenance of the Goulds Model 3410 Double Suction, Horizontally Split Case Pump. This manual covers the standard product plus common options that are available. For special options, supplemental instructions are supplied. This manual must be read and understood before installation and start-up.

The design, materials, and workmanship incorporated in the construction of Goulds pumps makes them capable of giving trouble-free service. The life and satisfactory service of any mechanical unit, however, is enhanced and extended by correct application, proper installation, periodic inspection, condition monitoring and careful maintenance. This instruction manual was prepared to assist operators in understanding the construction and the correct methods of installing, operating, and maintaining these pumps.

ITT Industries - Goulds shall not be liable for physical injury, damage or delays caused by a failure to observe the instructions for Installation, Operation, and Maintenance contained in this manual.



When pumping unit is installed in a potentially explosive atmosphere, the instructions after the  symbol must be followed. Personal injury and/or equipment damage may occur if these instructions are not followed. If there is any question regarding these requirements or if the equipment is to be modified, please contact a Goulds representative before proceeding.

Warranty is valid only when genuine ITT Industries - Goulds parts are used.

Use of the equipment on a service other than stated in the order will nullify the warranty, unless written approval is obtained in advance from Goulds Pumps, Inc.

Supervision by an authorized ITT Industries - Goulds representative is recommended to assure proper installation.

Additional manuals can be obtained by contacting your local ITT Industries - Goulds representative or by calling 1-800-446-8537.

THIS MANUAL EXPLAINS

- Proper Installation
- Start-up Procedures
- Operation Procedures
- Routine Maintenance
- Pump Overhaul
- Trouble Shooting
- Ordering Spare or Repair Parts

TABLE OF CONTENTS

| PAGE | SECTION | |
|-------------|-------------------------------------|----------|
| 7 | SAFETY | 1 |
| 11 | GENERAL INFORMATION | 2 |
| 15 | INSTALLATION | 3 |
| 25 | OPERATION | 4 |
| 37 | PREVENTIVE MAINTENANCE | 5 |
| 43 | DISASSEMBLY & REASSEMBLY | 6 |
| 77 | SPARE AND REPAIR PARTS | 7 |

IMPORTANT SAFETY NOTICE

To: Our Valued Customers

User safety is a major focus in the design of our products. Following the precautions outlined in this manual will minimize your risk of injury.

ITT Goulds pumps will provide safe, trouble-free service when properly installed, maintained, and operated.

Safe installation, operation, and maintenance of ITT Goulds Pumps equipment are an essential end user responsibility. This *Pump Safety Manual* identifies specific safety risks that must be considered at all times during product life. Understanding and adhering to these safety warnings is mandatory to ensure personnel, property, and/or the environment will not be harmed. Adherence to these warnings alone, however, is not sufficient — it is anticipated that the end user will also comply with industry and corporate safety standards. Identifying and eliminating unsafe installation, operating and maintenance practices is the responsibility of all individuals involved in the installation, operation, and maintenance of industrial equipment.

Please take the time to review and understand the safe installation, operation, and maintenance guidelines outlined in this Pump Safety Manual and the Instruction, Operation, and Maintenance (IOM) manual. Current manuals are available at www.gouldspumps.com/literature_ioms.html or by contacting your nearest Goulds Pumps sales representative.

These manuals must be read and understood before installation and start-up.

For additional information, contact your nearest Goulds Pumps sales representative or visit our Web site at www.gouldspumps.com.

SAFETY WARNINGS

Specific to pumping equipment, significant risks bear reinforcement above and beyond normal safety precautions.

 **WARNING**

A pump is a pressure vessel with rotating parts that can be hazardous. Any pressure vessel can explode, rupture, or discharge its contents if sufficiently over pressurized causing death, personal injury, property damage, and/or damage to the environment. All necessary measures must be taken to ensure over pressurization does not occur.

 **WARNING**

Operation of any pumping system with a blocked suction and discharge must be avoided in all cases. Operation, even for a brief period under these conditions, can cause superheating of enclosed pumpage and result in a violent explosion. All necessary measures must be taken by the end user to ensure this condition is avoided.

 **WARNING**

The pump may handle hazardous and/or toxic fluids. Care must be taken to identify the contents of the pump and eliminate the possibility of exposure, particularly if hazardous and/or toxic. Potential hazards include, but are not limited to, high temperature, flammable, acidic, caustic, explosive, and other risks.

 **WARNING**

Pumping equipment Instruction, Operation, and Maintenance manuals clearly identify accepted methods for disassembling pumping units. These methods must be adhered to. Specifically, applying heat to impellers and/or impeller retaining devices to aid in their removal is strictly forbidden. Trapped liquid can rapidly expand and result in a violent explosion and injury.

ITT Goulds Pumps will not accept responsibility for physical injury, damage, or delays caused by a failure to observe the instructions for installation, operation, and maintenance contained in this Pump Safety Manual or the current IOM available at www.gouldspumps.com/literature.

SAFETY

DEFINITIONS

Throughout this manual the words **WARNING**, **CAUTION**, **ELECTRICAL**, and **ATEX** are used to indicate where special operator attention is required.

Observe all Cautions and Warnings highlighted in this Pump Safety Manual and the IOM provided with your equipment.



WARNING

Indicates a hazardous situation which, if not avoided, could result in death or serious injury.

Example: Pump shall never be operated without coupling guard installed correctly.



CAUTION

Indicates a hazardous situation which, if not avoided, could result in minor or moderate injury.

Example: Throttling flow from the suction side may cause cavitation and pump damage.



ELECTRICAL HAZARD

Indicates the possibility of electrical risks if directions are not followed.

Example: Lock out driver power to prevent electric shock, accidental start-up, and physical injury.









When installed in potentially explosive atmospheres, the instructions that follow the Ex symbol must be followed. Personal injury and/or equipment damage may occur if these instructions are not followed. If there is any question regarding these requirements or if the equipment is to be modified, please contact an ITT Goulds Pumps representative before proceeding.













Example:  Improper impeller adjustment could cause contact between the rotating and stationary parts, resulting in a spark and heat generation.



GENERAL PRECAUTIONS

WARNING

A pump is a pressure vessel with rotating parts that can be hazardous. Hazardous fluids may be contained by the pump including high temperature, flammable, acidic, caustic, explosive, and other risks. Operators and maintenance personnel must realize this and follow safety measures. Personal injuries will result if procedures outlined in this manual are not followed. ITT Goulds Pumps will not accept responsibility for physical injury, damage or delays caused by a failure to observe the instructions in this manual and the IOM provided with your equipment.

| General Precautions | | |
|---------------------|---|--|
| WARNING | | NEVER APPLY HEAT TO REMOVE IMPELLER. It may explode due to trapped liquid. |
| WARNING | | NEVER use heat to disassemble pump due to risk of explosion from tapped liquid. |
| WARNING | | NEVER operate pump without coupling guard correctly installed. |
| WARNING |  | NEVER run pump below recommended minimum flow when dry, or without prime. |
| WARNING |  | ALWAYS lock out power to the driver before performing pump maintenance. |
| WARNING | | NEVER operate pump without safety devices installed. |
| WARNING |  | NEVER operate pump with discharge valve closed. |
| WARNING |  | NEVER operate pump with suction valve closed. |
| WARNING |  | DO NOT change service application without approval of an authorized ITT Goulds Pumps representative. |
| WARNING | | <p>Safety Apparel:</p> <ul style="list-style-type: none"> ♦ Insulated work gloves when handling hot bearings or using bearing heater ♦ Heavy work gloves when handling parts with sharp edges, especially impellers ♦ Safety glasses (with side shields) for eye protection ♦ Steel-toed shoes for foot protection when handling parts, heavy tools, etc. ♦ Other personal protective equipment to protect against hazardous/toxic fluids |
| WARNING | | <p>Receiving:</p> <p>Assembled pumping units and their components are heavy. Failure to properly lift and support equipment can result in serious physical injury and/or equipment damage. Lift equipment only at specifically identified lifting points or as instructed in the current IOM. Current manuals are available at www.gouldspumps.com/literature_ioms.html or from your local ITT Goulds Pumps sales representative. Note: Lifting devices (eyebolts, slings, spreaders, etc.) must be rated, selected, and used for the entire load being lifted.</p> |
| WARNING |  | <p>Alignment:</p> <p>Shaft alignment procedures must be followed to prevent catastrophic failure of drive components or unintended contact of rotating parts. Follow coupling manufacturer's coupling installation and operation procedures.</p> |

| General Precautions | | |
|----------------------------|---|---|
| WARNING |  | Before beginning any alignment procedure, make sure driver power is locked out. Failure to lock out driver power will result in serious physical injury. |
| CAUTION |  | Piping: Never draw piping into place by forcing at the flanged connections of the pump. This may impose dangerous strains on the unit and cause misalignment between pump and driver. Pipe strain will adversely effect the operation of the pump resulting in physical injury and damage to the equipment. |
| WARNING | | Flanged Connections: Use only fasteners of the proper size and material. |
| WARNING | | Replace all corroded fasteners. |
| WARNING | | Ensure all fasteners are properly tightened and there are no missing fasteners. |
| WARNING |  | Startup and Operation: When installing in a potentially explosive environment, please ensure that the motor is properly certified. |
| WARNING |  | Operating pump in reverse rotation may result in contact of metal parts, heat generation, and breach of containment. |
| WARNING |  | Lock out driver power to prevent accidental start-up and physical injury. |
| WARNING |  | The impeller clearance setting procedure must be followed. Improperly setting the clearance or not following any of the proper procedures can result in sparks, unexpected heat generation and equipment damage. |
| WARNING |  | If using a cartridge mechanical seal, the centering clips must be installed and set screws loosened prior to setting impeller clearance. Failure to do so could result in sparks, heat generation, and mechanical seal damage. |
| WARNING |  | The coupling used in an ATEX classified environment must be properly certified and must be constructed from a non-sparking material. |
| WARNING | | Never operate a pump without coupling guard properly installed. Personal injury will occur if pump is run without coupling guard. |
| WARNING |  | Make sure to properly lubricate the bearings. Failure to do so may result in excess heat generation, sparks, and / or premature failure. |
| CAUTION |  | The mechanical seal used in an ATEX classified environment must be properly certified. Prior to start up, ensure all points of potential leakage of process fluid to the work environment are closed. |
| CAUTION |  | Never operate the pump without liquid supplied to mechanical seal. Running a mechanical seal dry, even for a few seconds, can cause seal damage and must be avoided. Physical injury can occur if mechanical seal fails. |
| WARNING | | Never attempt to replace packing until the driver is properly locked out and the coupling spacer is removed. |
| WARNING |  | Dynamic seals are not allowed in an ATEX classified environment. |
| WARNING |  | DO NOT operate pump below minimum rated flows or with suction and/or discharge valve closed. These conditions may create an explosive hazard due to vaporization of pumpage and can quickly lead to pump failure and physical injury. |

| General Precautions | | |
|----------------------------|---|---|
| WARNING | | Ensure pump is isolated from system and pressure is relieved before disassembling pump, removing plugs, opening vent or drain valves, or disconnecting piping. |
| WARNING | | Shutdown, Disassembly, and Reassembly: Pump components can be heavy. Proper methods of lifting must be employed to avoid physical injury and/or equipment damage. Steel toed shoes must be worn at all times. |
| WARNING | | The pump may handle hazardous and/or toxic fluids. Observe proper decontamination procedures. Proper personal protective equipment should be worn. Precautions must be taken to prevent physical injury. Pumpage must be handled and disposed of in conformance with applicable environmental regulations. |
| WARNING | | Operator must be aware of pumpage and safety precautions to prevent physical injury. |
| WARNING |  | Lock out driver power to prevent accidental startup and physical injury. |
| CAUTION | | Allow all system and pump components to cool before handling them to prevent physical injury. |
| CAUTION |  | If pump is a Model NM3171, NM3196, 3198, 3298, V3298, SP3298, 4150, 4550, or 3107, there may be a risk of static electric discharge from plastic parts that are not properly grounded. If pumped fluid is non-conductive, pump should be drained and flushed with a conductive fluid under conditions that will not allow for a spark to be released to the atmosphere. |
| WARNING | | Never apply heat to remove an impeller. The use of heat may cause an explosion due to trapped fluid, resulting in severe physical injury and property damage. |
| CAUTION | | Wear heavy work gloves when handling impellers as sharp edges may cause physical injury. |
| CAUTION | | Wear insulated gloves when using a bearing heater. Bearings will get hot and can cause physical injury. |

ATEX CONSIDERATIONS and INTENDED USE

Special care must be taken in potentially explosive environments to ensure that the equipment is properly maintained. This includes but is not limited to:

1. Monitoring the pump frame and liquid end temperature.
2. Maintaining proper bearing lubrication.
3. Ensuring that the pump is operated in the intended hydraulic range.

The ATEX conformance is only applicable when the pump unit is operated within its intended use. Operating, installing or maintaining the pump unit in any way that is not covered in the Instruction, Operation, and Maintenance manual (IOM) can cause serious personal injury or damage to the equipment. This includes any modification to the equipment or use of parts not provided by ITT Goulds Pumps. If there is any question regarding the intended use of the equipment, please contact an ITT Goulds representative before proceeding. Current IOMs are available at www.gouldspumps.com/literature_ioms.html or from your local ITT Goulds Pumps Sales representative.

All pumping unit (pump, seal, coupling, motor and pump accessories) certified for use in an ATEX classified environment, are identified by an ATEX tag secured to the pump or the baseplate on which it is mounted. A typical tag would look like this:



The CE and the Ex designate the ATEX compliance. The code directly below these symbols reads as follows:

- II = Group 2
- 2 = Category 2
- G/D = Gas and Dust present
- T4 = Temperature class, can be T1 to T6 (see Table 1)

| Code | Max permissible surface temperature °F (°C) | Max permissible liquid temperature °F (°C) |
|-------------|--|---|
| T1 | 842 (450) | 700 (372) |
| T2 | 572 (300) | 530 (277) |
| T3 | 392 (200) | 350 (177) |
| T4 | 275 (135) | 235 (113) |
| T5 | 212 (100) | Option not available |
| T6 | 185 (85) | Option not available |

The code classification marked on the equipment must be in accordance with the specified area where the equipment will be installed. If it is not, do not operate the equipment and contact your ITT Goulds Pumps sales representative before proceeding.

PARTS



The use of genuine Goulds parts will provide the safest and most reliable operation of your pump. ITT Goulds Pumps ISO certification and quality control procedures ensure the parts are manufactured to the highest quality and safety levels.

Please contact your local Goulds representative for details on genuine Goulds parts.

GENERAL INFORMATION

PUMP DESCRIPTION 11
NAMEPLATE INFORMATION 13

PUMP DESCRIPTION

PUMP SERVICES

The Goulds 3410 model line is designed for a wide range of Industrial, Municipal, and Marine Services to include:

- Process – Quench Water, Stripper Bottoms, Reboiler Circulation, and Cooling Tower.
- Pulp and Paper – Primary and Secondary Cleaner, Filtrate, Mill Water Supply, and Fan Pump.
- Primary Metals – Cooling Water, Quench, and Leaching.
- Municipal – High Lift, Low Lift, Wash Water, Waste Water, and Raw Water.
- Utilities – Cooling Tower, Component Cooling, and Service Water.
- Marine – Bilge and Ballast, Cargo, Cooling Service, and Fire Pump.

CAPABILITIES AND FEATURES

Capabilities. Goulds Model 3410 is a single stage, double suction pump for capacities to 12,000 GPM (2667 M3/Hr.) and heads to 530 feet (161 meters). It is designed for pressure to 175 PSIG (1200 kilopascals) with cast iron and 250 PSIG (1725 kilopascals) with ductile iron or steel, and temperatures to 350°F (177°C).

Features. Pump sizes with an H designation are designed for a higher flow than the equivalent size standard pump. External casing dimensions are the same, but the H pumps have wider casing cutwaters and impellers.

The complete model line has four different shafts with only two bearing assemblies. Standard constructions are all iron, bronze fitted, 316SS fitted, and all 316SS, with other constructions available upon request.

Right hand rotation is standard with left hand available as an option. The rotation can be changed in the field without any additional parts.

Vertical Application. Goulds Model 3410 is available in a vertical configuration (3410V) (Fig. 1). This arrangement is ideal for applications with limited space such as shipboard service. A rugged fabricated steel frame supports the pump and driver, providing a machined fit for positive alignment when using standard P-base motors.

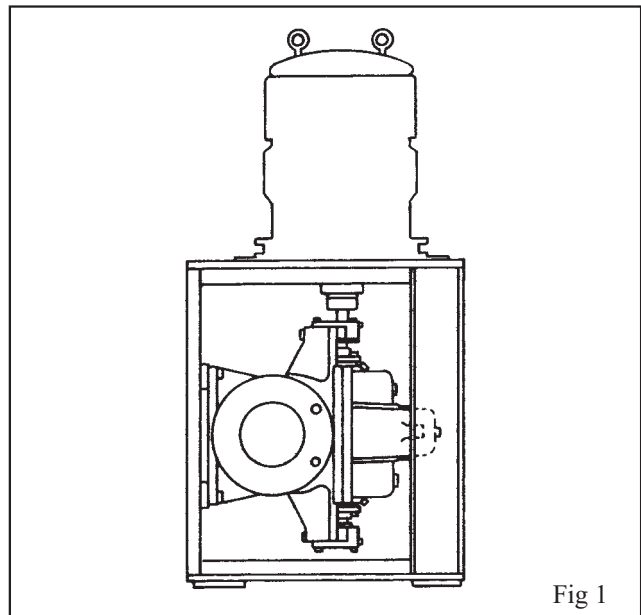



Fig 1

DESCRIPTION

 **Leakage of process liquid may result in creating an explosive atmosphere. Ensure the materials of the pump casing, impeller, shaft, sleeves, gaskets and seals are compatible with the process liquid.**

Casing - The casing is horizontally split. The upper and lower halves are held together with capscrews plus studs on each side of each stuffing box to aid in disassembly/reassembly. Flanged suction and discharge connections are located in the lower half of the casing and conform to ANSI 16.1/16.5 class 125/150. The casing is supported by integrally cast feet. Separate bearing housings are attached directly to machined fits in each end of the casing with capscrews. Fourteen of the 27 casings are double volute as tabulated on the next page.

| DOUBLE VOLUTE CASINGS | |
|----------------------------------|------------|
| 4x6-11 | 8x10-21 |
| 4x6-11H | 10x12-12 |
| 6x8-11 | 10x12-12H* |
| 8x10-12 | 10x12-14 |
| 8x10-14 | 10x12-17 |
| 8x10-17 | 10x12-15 |
| 8x10-17H | 12x14-14 |
| 12x14-15 | |
| *Casing uses a partial splitter. | |

125# flat face flanges are standard with 250# flat face available as an option. The casings are standard with two jack screws (except S group), two lifting lugs, two tapered dowel pins for alignment, and a 0.030 inch (.0762 cm) parting gasket.

The upper half casing is provided with a vent connection, a priming connection, and two stuffing box seal ring connections. The lower half is provided with two drain connections.

Impeller - The impeller is an enclosed, double suction design providing axial hydraulic balance. The impeller is dynamically balanced as standard when the diameter to width ratio is less than six. The impeller is key driven.

Wear Rings - Casing wear rings are supplied as standard to maintain proper running clearance and to minimize leakage between the suction and discharge chambers in the casing. Each casing ring is held in place by a single anti-rotation pin, located in a milled slot at the horizontal parting surface. Optional impeller wear rings are available on all pump sizes. The impeller wear rings are held in position by axial set screws. Field installation of impeller rings requires a remachining of the impeller hubs. The casing rings remain the same for both the less-impeller ring and with-impeller ring designs.

Shaft - The shaft is a heavy duty design that minimizes deflection and vibration. The shaft deflection is a maximum of .002 in (.005 mm) at the stuffing box face under the worst operating conditions. The shaft on the M, L and XL group pump is completely dry with gasket seals between the impeller hubs and shaft sleeves. The S group does not have a completely dry shaft. The S group is standard with a 420 stainless steel shaft. The M, L, and XL sizes have an ANSI 4140 steel shaft standard, with an option for 316 stainless steel.

Shaft Sleeves - The M, L and XL group pumps have standard Shaft Sleeves. They are keyed to the shaft at the

impeller and held axially in place using threaded sleeve nuts. The S group pumps are standard without shaft sleeves, but sleeves are available.

Stuffing Box - Non-asbestos stuffing box packing is standard. The stuffing box contains split lantern rings and renewable stuffing box throat bushings. Tapped openings are provided for water sealing from either the pump casing or an outside source. Bypass piping is optional. Two-piece investment cast 316SS non-quench glands are standard on all 3410 pumps.

Mechanical Seals - Mechanical seals are available as an option on the Model 3410. Oversize stuffing box bores are standard on pumps provided with factory installed mechanical seals, providing greater flexibility and an improved operating environment.

Pumps which are originally supplied with standard packed boxes can be converted to mechanical seals in the field. This conversion requires either a remachine of the stuffing boxes or a gland remachine to adapt to the existing stuffing boxes. Remachining of the stuffing box bores allows use of all standard Model 3410 mechanical seals and the standard I.D. pilot glands. Conversion to stepped sleeves would be required for balanced seals. Most unbalanced mechanical seals will fit in the standard packed box bores, but this requires remachining the I.D. pilot off the glands. In this case, the glands must be centered on the shaft or sleeve utilizing a feeler gauge.

Pumps supplied with mechanical seals can also be converted to packed boxes in the field. A cartridge conversion kit is available and includes a box of fittings, plus sleeves to convert to oversize bores to standard packed box bores.

Bearings - The Model 3410 is standard with double row ball thrust bearings and a single row deep groove ball bearing at the coupling end. There are only two sizes of bearing housings and bearings utilized on the complete Model 3410 product line. The S and M groups utilize identical bearings, as do the L and XL groups. The thrust bearing is held in position with a tapered snap ring and is locked in the thrust bearing housing to take any unbalanced axial thrust load. The radial bearing is free to float axially in the bearing housing taking radial loads only.



Grease lubrication is standard. Oil lubrication is optional and utilizes the same shaft, bearings, and bearing housings. Bearing cooling is available with oil lubrication only, and is required for temperatures over 250 degrees F (121 degrees C). The bearing housings are completely sealed by Inpro VBS bearing isolators.

Bedplates - Cast iron bedplates are furnished as standard. They include a drip collection chamber with a tapped drain connection and an opening suitable for grouting. Fabricated steel bedplates are available as an option.

NAMEPLATE INFORMATION

Every pump has a Goulds nameplate that provides information about the pump. The tags are located on the pump casing.

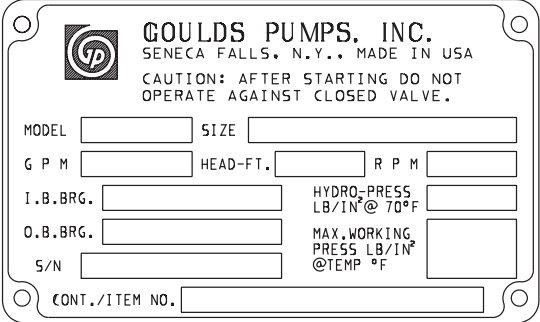
When ordering parts, you will need to identify the pump model, size, serial number, and the item number of the required parts. Information can be taken from the pump casing tags. Item numbers can be found later on in this manual.

| Description | Fig. No. | Example |
|---|----------|---|
| <p>Pump Casing Tag - provides information about the pump's hydraulic characteristics. Note the format of the pump size: Discharge x Suction - Nominal maximum Impeller Diameter in inches. (Example: 2x3-11) (Fig. 2).</p> | Fig. 2 |  |
| <p>ATEX Tag - If applicable, your pump unit may have the following ATEX tag affixed to the pump and/or baseplate. See the Safety section for a description of the symbols and codes (Fig. 3).</p> | Fig. 3 |  |

INSTALLATION

| | |
|---|-----------|
| RECEIVING THE PUMP | 15 |
| Storage Requirements | 15 |
| Lifting the Pump | 16 |
| Horizontal | 16 |
| Vertical | 17 |
| STORAGE. | 17 |
| Temporary | 17 |
| Long Term | 17 |
| LOCATION | 18 |
| FOUNDATION | 18 |
| SETTING THE BASEPLATE | 18 |
| Grouting Procedure | 19 |
| ALIGNMENT | 20 |
| Alignment Checks | 20 |
| DOWELING. | 22 |
| SUCTION AND DISCHARGE PIPING | 22 |
| Suction Piping | 22 |
| Discharge Piping | 24 |
| Pressure Gauges | 24 |



Equipment that will operate in a potentially explosive environment must be installed in accordance with the following instructions.

RECEIVING THE PUMP

Check pump for shortages and damage immediately upon arrival (an absolute must!). Prompt reporting to the carrier's agent, with notations made on the freight bill, will expedite satisfactory adjustment by the carrier.

Pumps and drivers are normally shipped from the factory mounted on a baseplate. Couplings may either be completely assembled or have the coupling hubs mounted on the shafts and the connecting members removed. When the connecting members are removed, they will be packaged in a separate container and shipped with the pump or attached to the baseplate.

STORAGE REQUIREMENTS

Short Term: (Less than 6 months): Goulds normal packaging procedure is designed to protect the pump during shipping. Upon receipt, store in a covered and dry location.

Long Term: (More than 6 months): Preservative treatment of bearings and machined surfaces will be required. Rotate shaft several times every three months. Refer to driver and coupling manufacturers for their long term storage procedures. Store in a covered dry location.

***NOTE:** Long term storage treatment can be purchased with the initial pump order.*

LIFTING THE PUMP



WARNING

Pump and components are heavy. Failure to properly lift and support the equipment could result in serious physical injury, or damage to the pump(s). Steel-toed shoes must be worn at all times.

The following instructions are for the safe lifting of your pump.

The unit should be unloaded and handled by lifting equally at four or more points on the baseplate. The lugs on the upper half casing are designed for lifting the upper half casing only.

HORIZONTAL

Bare Pump

1. Using a nylon sling, chain, or wire rope, hitch around both bearing housings. (See Fig. 4)

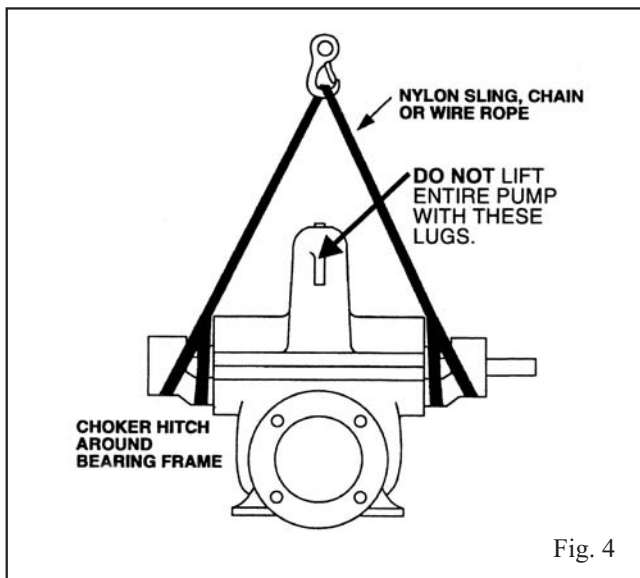

Pump, Base, and Driver

2. Care must be taken to size equipment for unbalanced loads which may exist if the driver is not mounted on the base at the time of lifting. Driver may or may not be mounted at the factory.
3. Pump, base, and driver assemblies where the base length exceeds 100 inches may not be safe to lift as a complete assembly. Damage to the baseplate may occur. If the driver has been mounted on the baseplate at the factory, it is safe to lift the entire assembly. If driver has not been mounted at the factory and the overall baseplate length exceeds 100 inches, do not lift entire assembly consisting of pump, base, and driver. Instead, lift the pump and baseplate to its final location without the driver. Then mount the driver.

Bases supplied with lifting holes

Large bases are supplied with lifting holes in the sides or the ends of the base. (See Fig. 5)

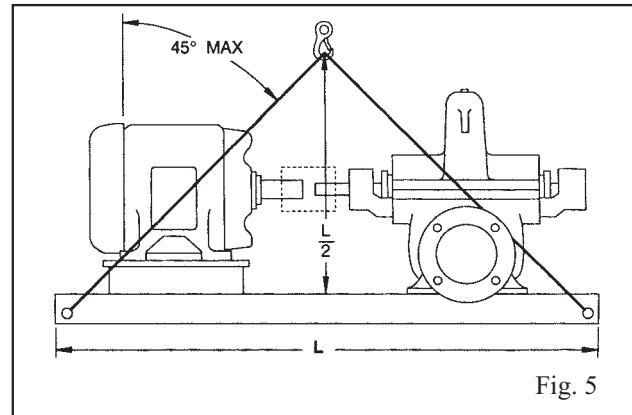

Using ANSI/OSHA Standard “S” hooks, place the “S” hooks in the holes provided in the four corners of the base. Be sure the points of the hooks do not touch the bottom of the pump base. Attach nylon slings, chains, or wire rope to the “S” hooks. Size the equipment for the load so the lift angle will be less than 45° from the vertical.

Bases supplied without lifting holes

Place one sling around the outboard bearing housing.



WARNING

Do not use lugs on top half of casing.

Place the remaining sling around the back end of the driver as close to the mounting feet as possible. Make certain sling will not damage housing cover or conduit boxes.

Join the free ends of the slings together and place over the lifting hook. Use extreme care when positioning sling under the driver and bearing housing so it cannot slip off (See Fig. 6).

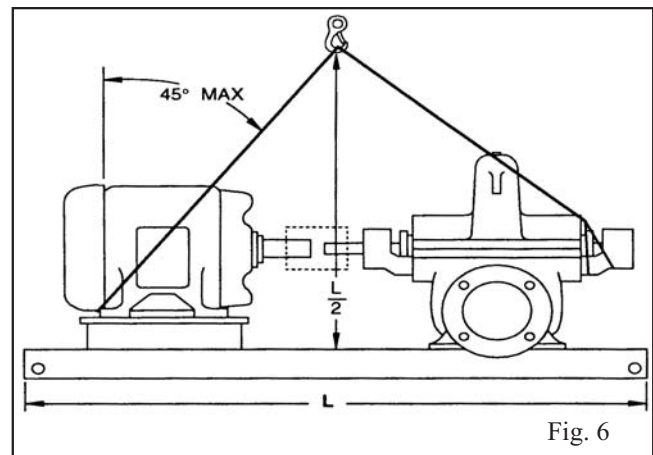

VERTICAL

Half Pedestal

1. Place nylon sling chain or wire rope around both flanges. Use a latch hook or standard shackle and end loops.

Be sure the lifting equipment is of sufficient length to keep the lift angle less than 30° from the vertical. (See Fig. 7)

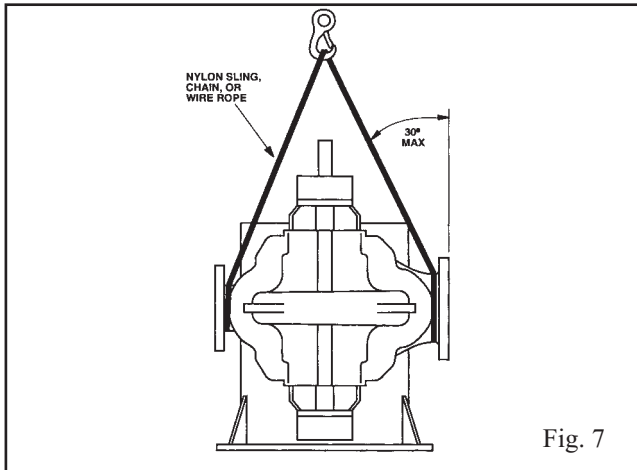

Full Pedestal

2. Install eyebolts in the three holes provided at the top of the support, being sure to tighten securely. Attach chain or wire rope using latch hook or standard shackle and end loop.

Be sure to use shoulder eyebolts that are manufactured per ANSI B18.15 and sized to fit the holes provided.

Be sure lifting equipment is of sufficient length to keep the lift angle less than 30° from the vertical. (See Fig. 8)

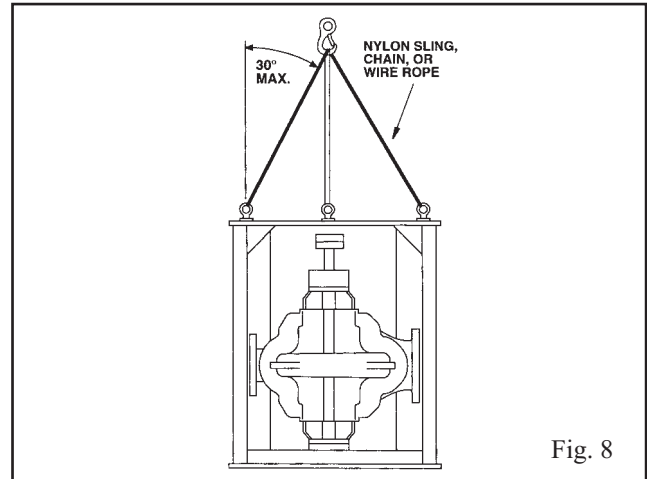

3

STORAGE

The following storage procedures apply to the pump only. Other accessories such as motors, steam turbines, gears, etc., must be handled per the respective manufacturer's recommendations.

TEMPORARY

Temporary storage is considered one month or less. If the pump is not to be installed and operated soon after arrival, store it in a clean, dry place having slow, moderate changes in ambient temperature. Rotate the shaft periodically to coat the bearings with lubricant and to retard oxidation, corrosion, and to reduce the possibility of false brinelling of the bearings. Shaft extensions and other exposed machine surfaces should be coated with an easily removable rust preventative such as Ashland Oil Tectyl No. 502C.

For oil lubricated bearings, fill the frame completely with oil. Before putting equipment into operation, drain the oil and refill to proper level.

LONG TERM

Storage longer than one month is considered long term storage. Follow the same procedure for temporary storage with the following addition. Add one half ounce of a corrosion inhibiting concentrated oil such as Cortec Corp. VCI-329 (for both grease and oil lubricated bearings). Seal all vents and apply a water proof tape around the oil seals in the bearing frame. Remember for oil lubricated bearings to drain the oil from the frame and refill to the proper level before running pump.

LOCATION

 **All equipment being installed must be properly grounded to prevent unexpected static electric discharge.**

The pump should be installed as near the suction supply as possible, with the shortest and most direct suction pipe practical. The total dynamic suction lift (static lift plus friction losses in suction line) should not exceed the limits for which the pump was sold.

The pump must be primed before starting. Whenever possible, the pump should be located below the fluid level to facilitate priming and assure a steady flow of liquid. This condition provides a positive suction head on the pump. It is also possible to prime the pump by pressurizing the suction vessel.

When installing the pump, consider its location in relation to the system to assure that sufficient Net Positive Suction Head (NPSHA) is available at the pump inlet connection. Available NPSH must always equal or exceed the required NPSH (NPSHR) of the pump.

The pump should be installed with sufficient accessibility for inspection and maintenance. A clear space with ample head room should be allowed for the use of an overhead crane or hoist sufficiently strong to lift the unit.

NOTE: Allow sufficient space to be able to dismantle pump without disturbing the pump inlet and discharge piping.

Select a dry place above the floor level wherever possible. Take care to prevent pump from freezing during cold weather when not in operation. Should the possibility of freezing exist during a shut-down period, the pump should be completely drained, and all passages and pockets where liquid might collect should be blown out with compressed air.

Make sure there is a suitable power source available for the pump driver. If motor driven, the electrical characteristics of the power source should be identical to those shown on motor data plate.

FOUNDATION

The foundation must be substantial enough to absorb vibration. (*Hydraulic Institute Standards* recommends the foundation weigh at least five (5) times the weight of the pump unit.) It must form a permanent and rigid support for the baseplate. This is important in maintaining the alignment of a flexibly coupled unit.

Foundation bolts of the proper size should be embedded in the concrete to a depth of eight (8) to twelve (12) inches and locked with either a hook around a reinforcing bar or alternatively, a nut and washer at the bottom. The bolts should have a sleeve around them at least six (6) times the bolt diameter in length and at least two (2) bolt sizes larger in I.D. If a nut and washer are used for locking, the washer should have an O.D. two (2) sizes larger than the sleeve. Foundation bolts should be sized .125" less than the anchor bolt holes in the base.

The foundation should be poured to within .75" - 1.5" of the finished height. (See Fig. 9) Freshly poured foundations should be allowed to cure for several days before the unit is set in place and grouted.

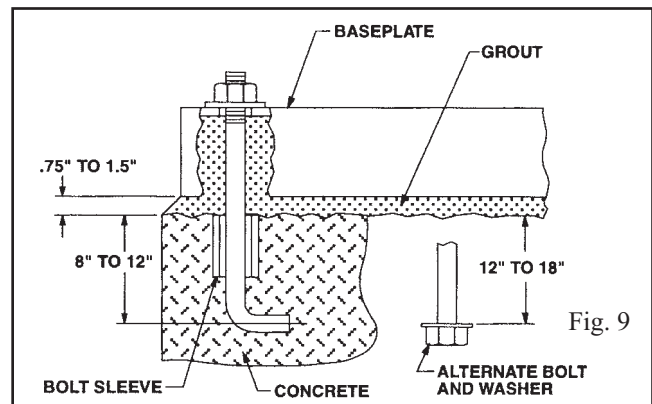

SETTING THE BASEPLATE

Pump units are checked at the factory for align ability to required tolerances.

Due to flexibility of an ungrouted base and handling in shipment, it should not be assumed that the unit is in alignment when it is placed on the rough foundation.

If these directions are followed, the required alignment should be readily achieved.

Initial or rough alignment must be done prior to grouting of baseplate. Rough alignment is designated as .020" TIR (Total Indicator Reading) parallel alignment and .009" TIR per inch of radius angular alignment (See ALIGNMENT PROCEDURE). Use blocks at anchor bolts and midway between to position bottom of base at finished height (See Fig. 10) with foundation bolts extending through holes in the baseplate. Metal wedges with a small taper may be used in lieu of blocks and shims.

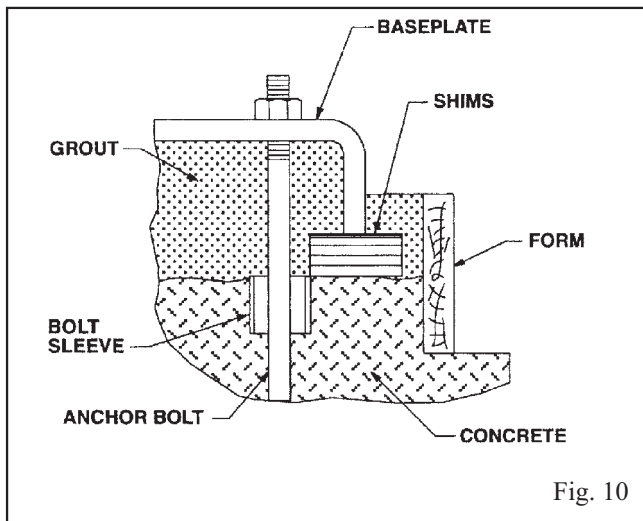

Fig. 10

If the unit has a non-flexible coupling (e.g. Falk Gear coupling), the coupling halves should be disconnected; this is generally not necessary on flexible type couplings (e.g. Wood's Sure-Flex coupling).

Tighten up all pump and motor bolts to assure they have not loosened or a "soft foot" has occurred due to base distortion in shipment. A "soft foot" causes a change in the alignment when unloosening one bolt.

If the driver is being field installed, it should be centered in its bolt holes with shims added to bring the driver into rough alignment with the pump. (The pump may have to be moved also.)



CAUTION

Do not exceed six (6) shims, using as thick a shim as possible, otherwise "sponginess" or "soft foot" will result. Place thin shims in between thick shims.

Level and plumb the pump shaft, coupling faces and flanges by adding or removing shims between the blocks and the bottom of the base. Hand tighten the anchor bolt nuts at first. Being very careful not to distort the base, snug down the nuts with a wrench. The non-flexible coupling should not be reconnected until the alignment operation has been completed.

NOTE: *The baseplate does not have to be level.*

After foundation bolts are lightly torqued, recheck alignment requirements once more. Follow requirements outlined at the beginning of this section. If alignment must be corrected, add or remove shims or wedges under the baseplate.

The unit can then be grouted. (See Fig. 10)

Grout compensates for the uneven foundation. Together with the baseplate, it makes a very rigid interface between the pump and the foundation distributing the weight over the length of the base and preventing shifting.

Use an approved, non-shrinking grout such as Embecco 636 or 885 by Master Builders, Cleveland, Ohio or equivalent.



CAUTION

Do not grout until initial alignment is made.



3

GROUTING PROCEDURE

1. Build a strong form around the foundation to contain the grout.
2. Soak the top of the foundation thoroughly, then remove surface water.
3. The baseplate should be completely filled with grout and, if necessary, temporarily use air relief tubing or drill vent holes to remove trapped air.
4. After the grout has thoroughly hardened (approximately 24 hours), tighten the foundation bolts fully.
5. Check the alignment after the foundation bolts are tightened.
6. Approximately fourteen (14) days after the grout has been poured and the grout has thoroughly dried, apply an oil base paint to the exposed edges of the grout to prevent air and moisture from coming in contact with the grout.

ALIGNMENT

 **Alignment procedures must be followed to prevent unintended contact of rotating parts. Follow coupling manufacturer's installation and operation procedures.**

   **WARNING**
Before beginning any alignment procedure, make sure driver power is locked out. Failure to lock out driver power may result in serious physical injury.

Alignment is achieved by adding or removing shims from under the feet of the driver and shifting equipment horizontally as needed.

NOTE: Proper alignment is the responsibility of the installer and user of the unit.

Accurate alignment of the equipment must be attained.

ALIGNMENT CHECKS

Initial Alignment (Cold Alignment)

- Before Grouting Baseplate - To ensure alignment can be obtained.
- After Grouting Baseplate - To ensure no changes have occurred during grouting process.
- After Connecting Piping - To ensure pipe strains have not altered alignment. If changes have occurred, alter piping to remove pipe strains on pump flanges.

Final Alignment (Hot Alignment)

- After First Run - To obtain correct alignment when both pump and driver are at operating temperature. Thereafter, alignment should be checked periodically in accordance with plant operating procedures.

NOTE: Alignment check must be made if process temperature changes, piping changes and or pump service is performed.

Proper rough alignment must be made during unit setting and grouting. See previous section.

There are two forms of misalignment between the pump shaft and the driver shaft as follows:

1. **Angular misalignment** — shafts have axis concentric at intersection, but not parallel.
2. **Parallel offset misalignment** — shafts have axis parallel, but offset.

NOTE: During installation phase, however, it is necessary to set the parallel alignment in the vertical direction to a different criteria due to the differences in expansion rates of the pump and driver. Table 2 shows recommended preliminary (cold) settings for electric motor driven pumps based on different pumpage temperatures. Driver manufacturers should be consulted for recommended cold settings of other types of drivers (steam turbines, engines, etc.)

| Pumpage Temperature Above Ambient Temperature | Set Motor Shaft |
|---|--|
| Ambient | 0.002" (0.005mm) - .004" (0.010mm) Low |
| 100° F (38° C) | 0.000" (0.0mm) - .002" (0.005mm) High |
| 200° F (93° C) | 0.004" (0.010mm) - .006" (0.15mm) High |
| 300° F (149° C) | 0.008" (0.020mm) - .010" (0.25mm) High |
| 400° F (204° C) | 0.012" (0.030mm) - .014" (0.35mm) High |

The necessary tools for checking alignment are: (1) a straight edge and a taper gauge or set of feeler gauges or, (2) a dial indicator with mounting magnet and extension bars.

Check and correct for angular misalignment before correcting parallel alignment. Final alignment should be made by moving and shimming the motor on its base until the coupling hubs are within the recommended tolerances measured in total run out. All measurements should be taken with the pump and driver bolts tightened. Final alignment check should be made after the unit has attained its final operating temperature.

Method 1 - Using straight edge and taper gauges or feelers (Fig. 11):

Proceed with this method only if satisfied that face and outside diameters of the coupling halves are square and concentric with the coupling bores. If this condition does not exist or elastomeric couplings do not make this method convenient, use Method 2.

Check for angular alignment by inserting the taper or feeler gauges between the coupling faces at 90° intervals. The unit is in angular alignment when these four (4) measurements are the same, or within recommended tolerances.

Check for parallel alignment by placing a straight edge across both coupling rims on all four sides. The unit is in parallel alignment when the straight edge rests evenly across both coupling rims in all four (4) positions.

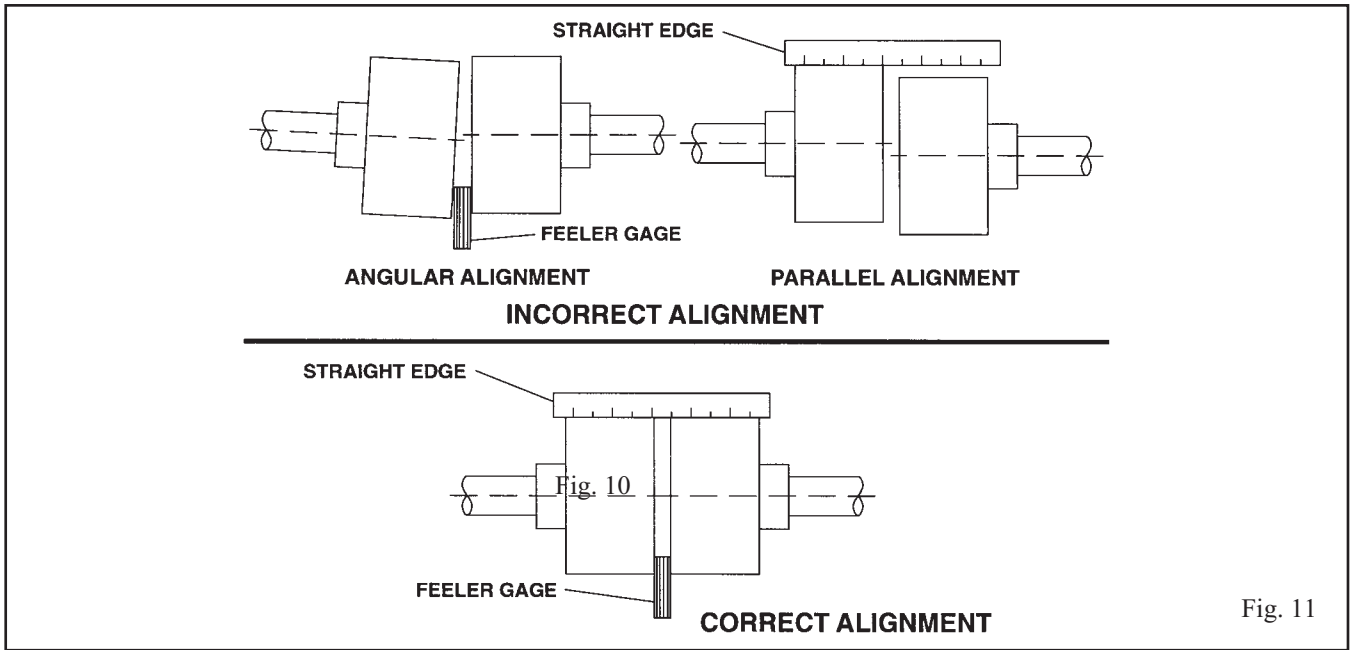

Fig. 11

Method 2 - Dial Indicators (Fig. 12):

A dial indicator can be used to attain more accurate alignment.

Fasten the indicator stand or magnetic base to the pump half of the coupling and adjust the assembly until the indicator button is resting on the other half coupling periphery.

Set the dial to zero and chalk mark the coupling half where the button rests. Also place a separator between the coupling halves so bearing slack does not affect the readings. (Chalk and separators are not necessary on the elastomeric couplings that have not been disconnected.) Rotate both shafts by the same amount; i.e., all readings must be made with the button on the chalk mark.

The dial readings will indicate whether the driver has to be raised, lowered or moved to either side. Accurate alignment

of shaft centers can be obtained with this method even where faces or outside diameters of the coupling are not square or concentric with the bores. After each adjustment, recheck both parallel and angular alignments.

NOTE: Gross deviations in squareness or concentricity may cause rotation unbalance problems and if so must be corrected.

| PERMISSIBLE COUPLING MISALIGNMENT | | |
|--|----------------------------------|---|
| | Single Element Coupling | Double Element (spacer) Coupling |
| Parallel | .004" TIR (4 mils) | .060" TIR per foot of spacer length |
| Angular | .004" TIR per inch of radius. | .002" TIR per inch of radius |

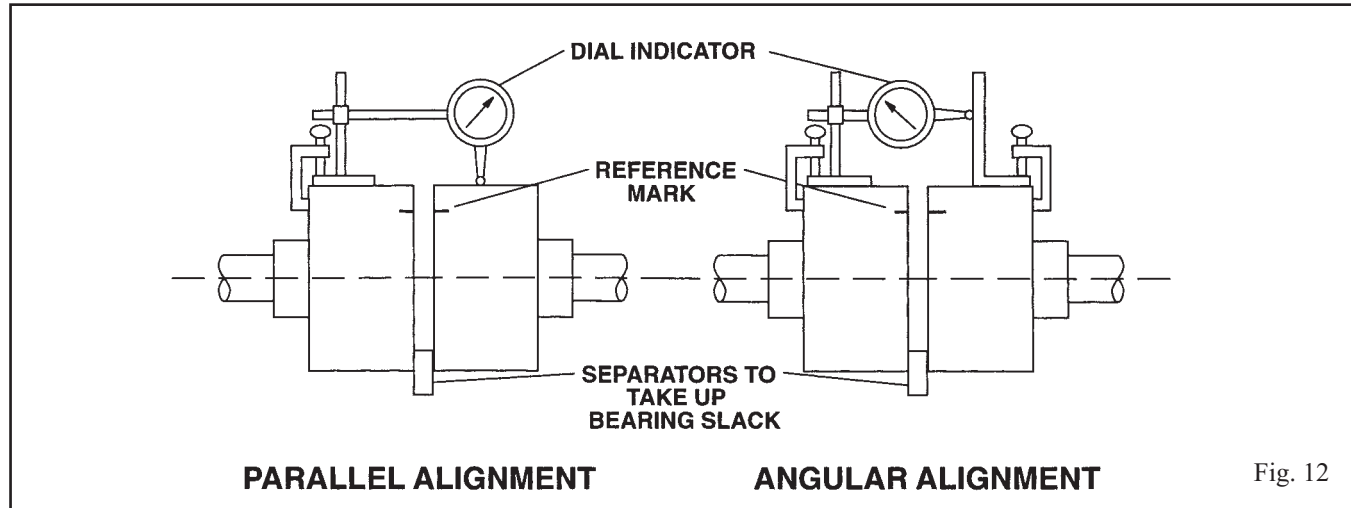

Fig. 12

DOWELING

Pump units may, if desired, (or required in specification) be doweled on diagonally opposite feet. This should not be

done until the unit has been run for a sufficient length of time and alignment is within the above alignment tolerance.

SUCTION AND DISCHARGE PIPING



Flange loads from the piping system, including those from thermal expansion of the piping, must not exceed the limits of the pump. Casing deformation can result in contact with rotating parts which can result in excess heat generation, sparks and premature failure.

The introduction of pumpage into a piping system which is not well designed or adjusted may cause strain on the pump, leading to misalignment or even impeller rubbing. Since slight strain may go unnoticed, final alignment should be done with the system full and up to final temperature.

Pipe flanges should not impose any strain on the pump. This can be checked by a dial indicator. Any strain must be corrected by adjustments in the piping system.

When installing the pump piping, be sure to observe the following precautions:

Piping should always be run to the pump.

Do not move the pump to pipe. This could make final alignment impossible.

Both the suction and discharge piping should be independently anchored near the pump and properly aligned so that no strain is transmitted to the pump when the flange bolts are tightened. Use pipe hangers or other supports at necessary intervals to provide support. When expansion joints are used in the piping system they must be installed beyond the piping supports closest to the pump. Tie bolts and spacer sleeves should be used with expansion joints to prevent pipe strain. Do not install expansion joints next to the pump or in any way that would cause a strain on the pump resulting from system pressure changes. When using rubber expansion joints, follow the recommendations of the *Technical Handbook on Rubber Expansion Joints and Flexible Pipe Connectors*. It is usually advisable to increase the size of both suction and discharge pipes at the pump connections to decrease the loss of head from friction.

Install piping as straight as possible, avoiding unnecessary bends. Where necessary, use 45° or long radius 90° fittings to decrease friction losses.

Make sure that all piping joints are air-tight.

Where flanged joints are used, assure that inside diameters match properly.

Remove burrs and sharp edges when making up joints.

Do not “spring” piping when making any connections.

Provide for pipe expansion when hot fluids are to be pumped.

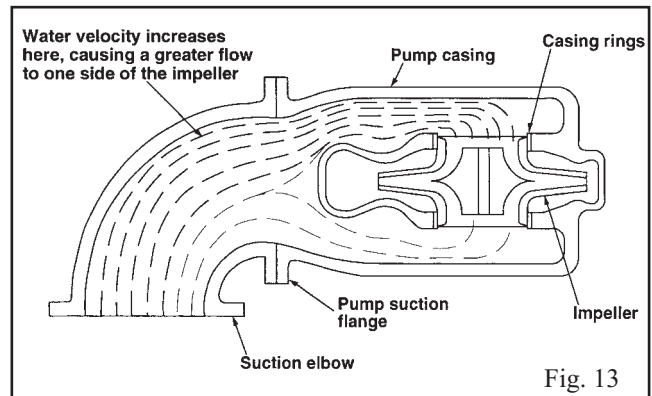

Fig. 13

SUCTION PIPING

When installing the suction piping, observe the following precautions. (See Fig. 14)

The sizing and installation of the suction piping is extremely important. It must be selected and installed so that pressure losses are minimized and sufficient liquid will flow into the pump when started and operated.

Many NPSH (Net Positive Suction Head) problems can be directly attributed to improper suction piping systems.

Suction piping should be short in length, as direct as possible, and never smaller in diameter than the pump suction opening. A minimum of five (5) pipe diameters between any elbow or tee and the pump should be allowed. If a long suction pipe is required, it should be one or two sizes larger than the suction opening, depending on its length.



CAUTION

An elbow should not be used directly before the suction of a double suction pump if its plane is parallel to the pump shaft. This can cause an excessive axial load or NPSH problems in the pump due to an uneven flow distribution (See Fig. 13). If there is no other choice, the elbow should have straightening vanes to help evenly distribute the flow.

Eccentric reducers should be limited to one pipe size reduction each to avoid excessive turbulence and noise. They should be of the conical type. Contour reducers are not recommended.

When operating on a suction lift, the suction pipe should slope upward to the pump nozzle. A horizontal suction line must have a gradual rise to the pump. Any high point in the pipe can become filled with air and prevent proper operation of the pump. When reducing the piping to the suction opening diameter, use an eccentric reducer with the eccentric side down to avoid air pockets.

NOTE: *When operating on suction lift never use a concentric reducer in a horizontal suction line, as it tends to form an air pocket in the top of the reducer and the pipe.*

Fig. 14 shows some correct and incorrect suction piping arrangements.

When installing valves in the suction piping, observe the following precautions:

1. If the pump is operating under static suction lift conditions, a foot valve may be installed in the suction line to avoid the necessity of priming each time the pump is started. This valve should be of the flapper type, rather than the multiple spring type, sized to

avoid excessive friction in the suction line. (Under all other conditions, a check valve, if used, should be installed in the discharge line. See Discharge Piping.)

2. When foot valves are used, or where there are other possibilities of “water hammer,” close the discharge valve slowly before shutting down the pump.
3. Where two or more pumps are connected to the same suction line, install gate valves so that any pump can be isolated from the line. Gate valves should be installed on the suction side of all pumps with a positive pressure for maintenance purposes. Install gate valves with stems horizontal to avoid air pockets. Globe valves should not be used, particularly where NPSH is critical.



CAUTION

3

The pump must never be throttled by the use of a valve on the suction side of the pump. Suction valves should be used only to isolate the pump for maintenance purposes, and should always be installed in positions to avoid air pockets.

DISCHARGE PIPING

If the discharge piping is short, the pipe diameter can be the same as the discharge opening. If the piping is long, the pipe diameter should be one or two sizes larger than the discharge opening. On long horizontal runs, it is desirable to maintain as even a grade as possible. Avoid high spots, such as loops, which will collect air and throttle the system or lead to erratic pumping.

A check valve and an isolating gate valve should be installed in the discharge line. The check valve, placed between pump and gate valve, protects the pump from excessive back pressure, and prevents liquid from running back through the pump in case of power failure. The gate valve is used in priming and starting, and when shutting the pump down.

PRESSURE GAUGES

Properly sized pressure gauges should be installed in both the suction and discharge nozzles in the gauge taps provided. The gauges will enable the operator to easily observe the operation of the pump, and also determine if the pump is operating in conformance with the performance curve. If cavitation, vapor binding, or other unstable operation should occur, widely fluctuating discharge pressure will be noted.

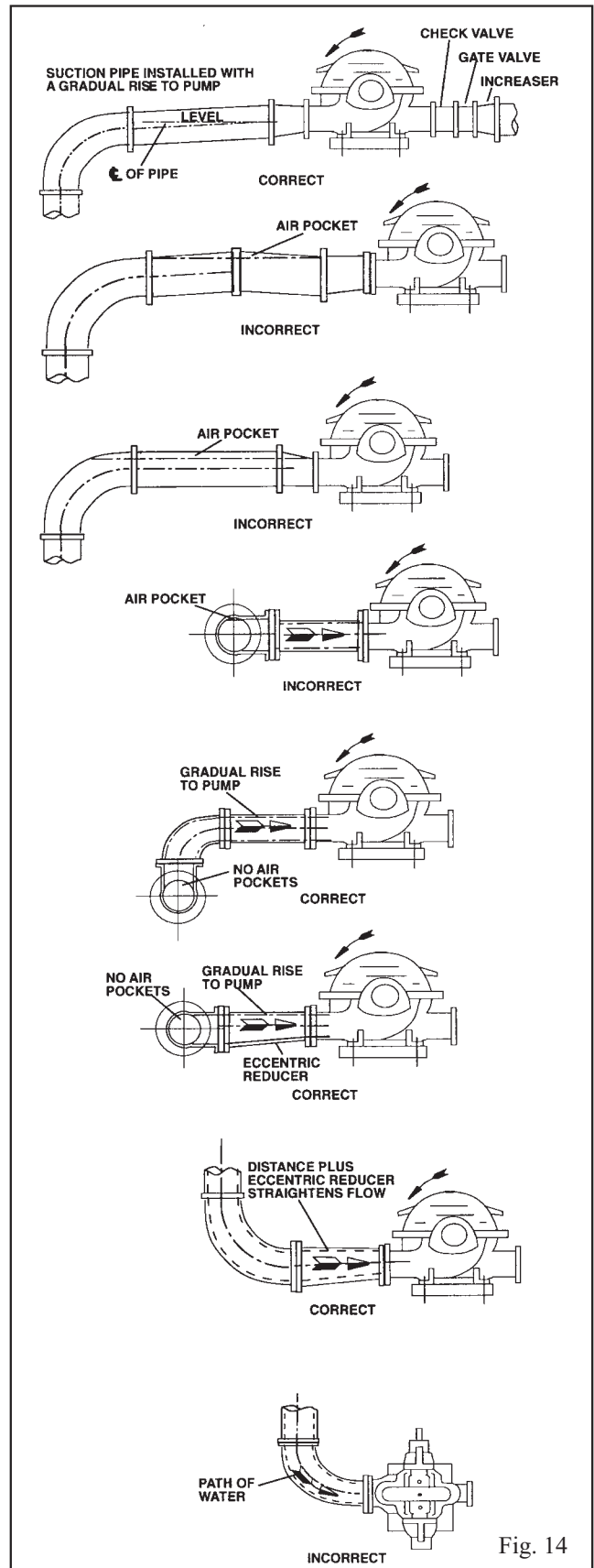



Fig. 14

OPERATION

| | |
|---|-----------|
| PREPARATION FOR STARTUP | 25 |
| Checking Rotation | 25 |
| Couple Pump and Driver | 25 |
| Lubricating Bearings | 26 |
| Shaft Sealing Packing | 27 |
| Connection of Sealing Liquid (Packed Box) | 29 |
| Mechanical Seal Flushing/Cooling Piping | 30 |
| Connection of Drain Piping | 30 |
| Priming the Pump | 30 |
| STARTING THE PUMP | 33 |
| OPERATION | 33 |
| SHUTDOWN | 34 |
| FINAL ALIGNMENT | 34 |

PREPARATION FOR STARTUP

 *Service temperature in an ATEX classified environment is limited to the area classification specified on the ATEX tag affixed to the pump (reference Table 1 in the Safety section for ATEX classifications).*

 *Ensure that pump and systems are free of foreign objects before operating and that objects cannot enter the pump during operation. Foreign objects in the pumpage or piping system can cause blockage of flow which can result in excess heat generation, sparks and premature failure.*

 *Cooling systems such as those for bearing lubrication, mechanical seal systems, etc, where provided, must be operating properly to prevent excess heat generation, sparks, and premature failure.*

 *When installing in a potentially explosive environment, ensure that the motor is properly certified.*

CHECKING ROTATION

  **CAUTION**

Serious damage may result if pump is run in the wrong rotation.

1. Lock out power to driver.

 **WARNING**
Lock out driver power to prevent accidental start-up and physical injury.

2. Make sure coupling hubs are securely fastened to the shafts and the coupling spacer has been removed.

NOTE: Pump is shipped with coupling spacer removed.

3. Unlock driver power.
4. Make sure everyone is clear. Jog driver just long enough to determine direction of rotation. Rotation must correspond to arrow on bearing housing.
5. Lock out power to driver.

COUPLE PUMP AND DRIVER

  **WARNING**
Lock out driver power to prevent accidental rotation and physical injury.

 *The coupling used in an ATEX classified environment must be properly certified.*

1. Install and lubricate coupling per manufacturer's instructions.
2. Install coupling guard.

 *The coupling guard used in an ATEX classified environment must be constructed from a non-sparking material.*

 **WARNING**
Never operate a pump without coupling guard properly installed. Personal injury will occur if pump is run without coupling guard.

LUBRICATING BEARINGS

 **Bearings must be lubricated properly in order to prevent excess heat generation, sparks and premature failure.**

 **Do not insulate bearing housings as this can result in excess heat generation, sparks and premature failure.**

Grease Lubrication (Standard). Grease lubricated pumps can be identified by grease fittings located on bearing housing. Sufficient lubricant is inserted at factory for 2,000 hours of operation. See Preventive Maintenance for grease lubrication instructions.

Oil Lubrication (Optional). Oil lubricated pumps are not lubricated at factory. A high quality turbine type oil, with rust and oxidation inhibitors, should be used. Constant level oilers are supplied with most oil lubricated pumps.

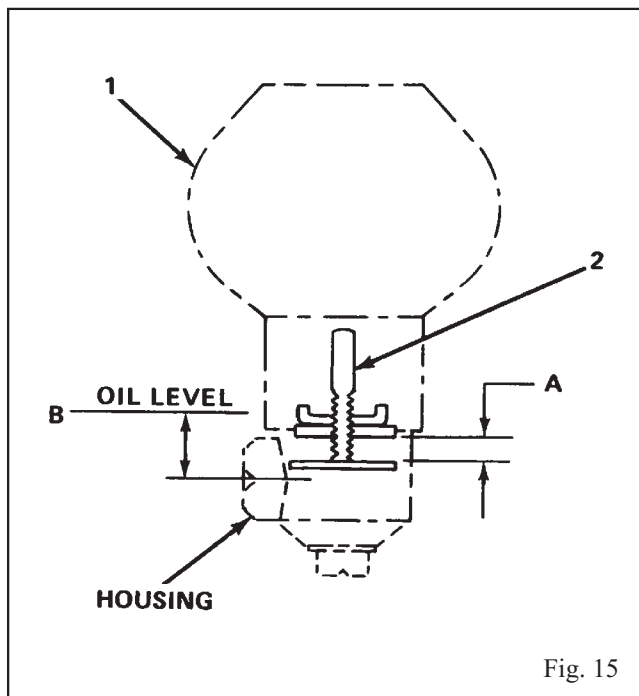

They are included in box of fittings which accompanies the pump. Oil adjustments must be set prior to lubrication. See Preventive Maintenance for recommended lubricants and supplies.

For Initial Oil Lubrication of New Bearings

1. Remove oiler (1), Fig. 15.
2. Remove adjustment assembly (2) from oiler.
3. Adjust bars to dimension A, as required, Table 3.
4. Lock in position.
5. Replace adjustment assembly in oiler.
6. Install oiler.

 **CAUTION**
Bar adjust must be adjusted as stated in procedure c(3). If not adjusted properly, bearing will not be lubricated.

NOTE: Never fill through oil vent or oiler housing.

| GROUP | A | B | OILER SIZE | CASING CAPACITY |
|--------|---------------|------------|----------------|------------------|
| | in. (mm) | in. (mm) | ounces (ml) | ounces (ml) |
| S & M | 9/16 (14.5mm) | 1/2 (13mm) | #5 8oz (204ml) | 9oz (266ml) |
| L & XL | 9/16 (14.5mm) | 1/2 (13mm) | #5 8oz (204ml) | 16 1/2oz (489ml) |

7. Fill each bottle with oil and replace in oiler housing. Oil reservoir in bearing housing is filled when oil remains visible in bottle. Several fillings of bottle are required.

Bearing cooling is available with oil lubrication (optional) only. When used, cooling water must be connected to bearing housing, and a waste or return line must be used. Water cooling is required when operating temperatures exceed 250° F (121°C).

DRIVER BEARINGS

Check to be sure that driver bearings are properly lubricated. Contact motor manufacturer for lubrication instructions.

SHAFT SEALING PACKING

Packing

⚠ Packed stuffing boxes are not allowed in an ATEX classified environment.

1. Before packing stuffing box, make sure box is clean and contains no foreign material.
2. Install gland studs into the casing if not already installed.
3. Stuffing box packing furnished in box of fittings which accompanies pump. When packing stuffing box arrangement of packing and lantern rings is: two packing rings, lantern ring; then last three packing rings, as shown in Fig. 16.

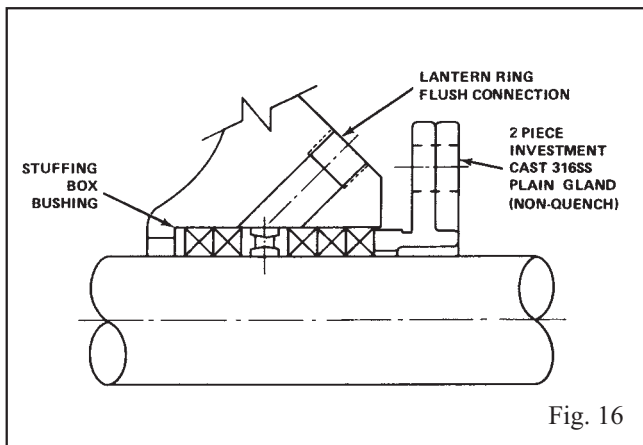

4. Twist packing ring sideways just enough to get it around shaft or sleeve (Fig. 17).

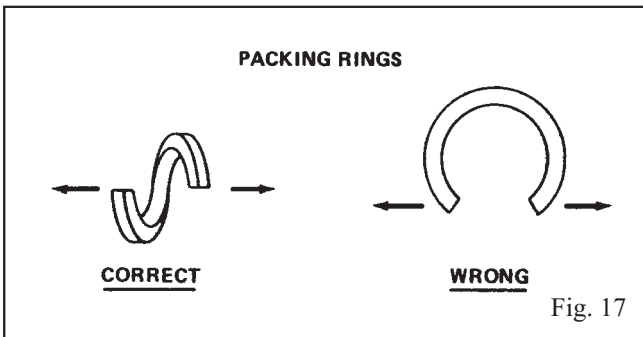

5. Two-piece Teflon lantern rings are supplied in all 3410s. Twist lantern ring halves just enough to get it around shaft sleeve as shown in Fig. 18.

NOTE: Two pieces make one ring. Notches must face one another but need not be aligned.

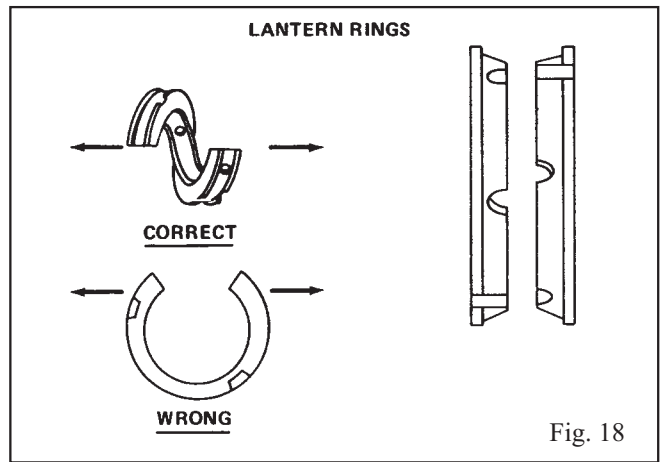

6. To pack stuffing box, install packing and lantern ring in proper sequence. Each ring should be installed separately. Firmly seat each ring. Use stuffing box gland to push packing and lantern ring into box, Fig. 19. Stagger joints in each ring 90 degrees. Make sure center of lantern ring lines up with flush tap in stuffing box. Any extra rings are spares.

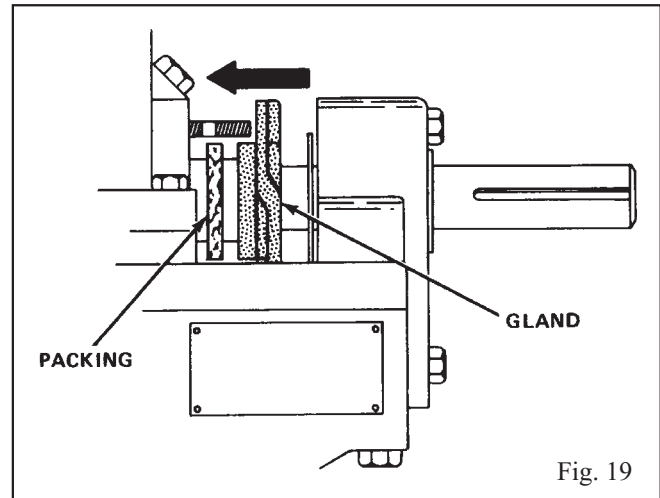

7. Hand-tighten gland nuts evenly but not tight.

Removal of Packing

To remove packing from stuffing box, proceed as follows:

1. Remove gland assembly.
2. Remove packing with a packing hook.
3. Remove lantern ring by inserting a wire hook into ring on outer edge.
4. Clean stuffing box.

An alternate method of removing packing is to remove upper half casing (see Disassembly & Reassembly section.) Remove packing and lantern ring and inspect sleeves and/or shaft. Replace sleeves or shaft if deeply grooved.

Mechanical Seals



The mechanical seal used in an ATEX classified environment must be properly certified.

When mechanical seals are furnished, description and identification is indicated on order write-ups. Separate seal manufacturer's installation drawings are attached to pump. Most seals are installed and adjusted at the factory. Manufacturer's drawings should be filed for future use in maintaining seal and in adjusting seal when pump is disassembled. To properly prepare seal for operation, various cooling and flushing flows may have to be connected. In some cases, these flows are recirculated from pump casing; in others, liquid from an outside source may be used. Connect cooling and flushing flows to seal as directed in manufacturer's instructions.

- All Model 3410 mechanical seals utilize o-ring mounted stationary seats and a flush gland with a pilot fit in the I.D. of the stuffing box as standard. All S group pumps are standard less shaft sleeves, with sleeves available as an option. M, L, and XL groups are standard with shaft sleeves and sleeve nuts.

A single inside unbalanced or integrally balanced (metal bellows) seal for an S group pump is illustrated in Fig. 20. This design incorporates the standard 420SS sleeveless shaft and oversized stuffing box bore. The stuffing box bore is used to pilot the standard gland.

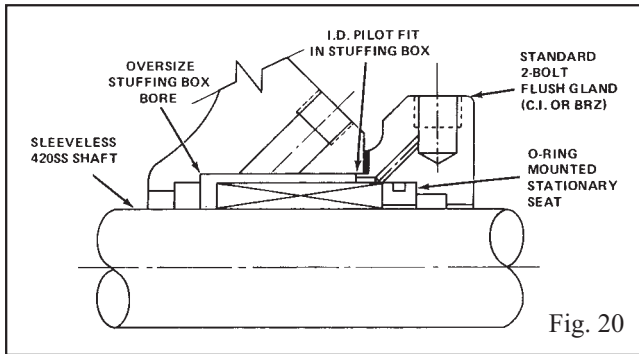

- Figure 21 illustrates the same type of seal as shown in Fig. 20, but for M group pumps. Note the shaft is protected by sleeves and sleeve nuts as standard. All other features and details are the same.

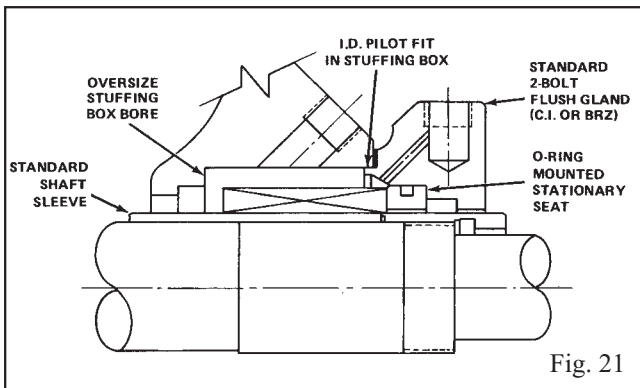

- Conventional balanced seals require the use of a stepped shaft sleeve. Figure 22 shows an S group pump with a stub sleeve to accomplish the seal balancing. A standard stepped sleeve is used on the M group to reduce the mounting diameter down to the standard sleeve nut O.D.. This is illustrated in Fig. 23. Bellows type mechanical seals are integrally balanced and do not require a step in the sleeve. They can be mounted directly on the sleeveless S group shaft of on the standard non-balanced M group sleeve (Fig. 21.)

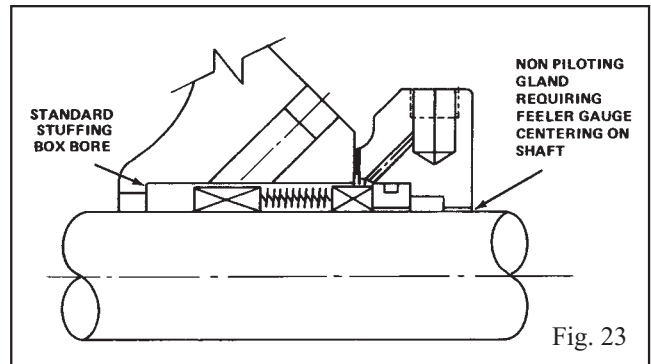
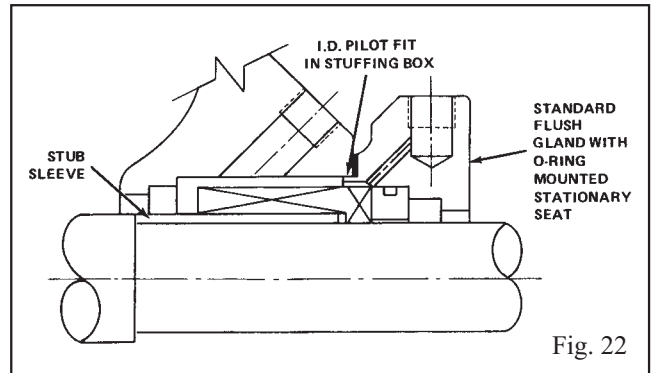

- Pumps which are originally supplied with packing boxes can be converted to mechanical seals in the field. This conversion requires a remachine of the stuffing box to allow for the standard gland pilot feature (Figures 20 and 21) or a remachine operation of the standard gland to remove the pilot lip (Figures 24 and 25.) In this case, a shimming operation is required to center the gland on the shaft.

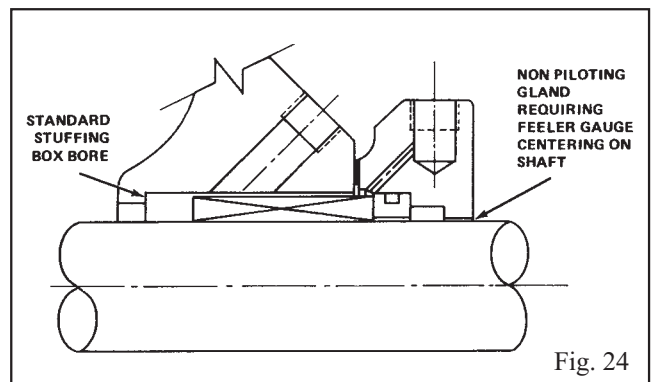

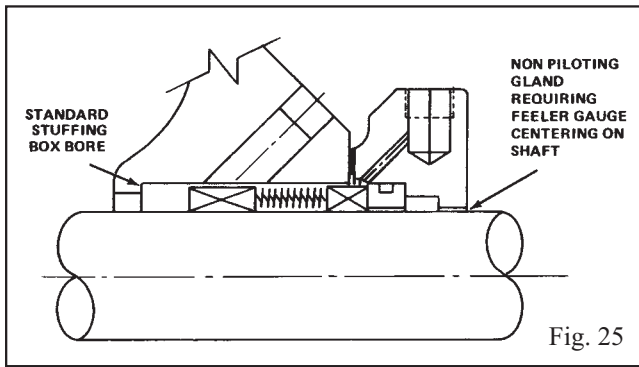

- Figure 24 shows a single inside unbalanced mechanical seal mounted in the S group standard stuffing box. You will note that the pilot lip has been machined off the gland since there is inadequate room in the bore for the pilot. With this arrangement, it is necessary to use a feeler gauge or shims to center the gland on the shaft.
- Figure 25 shows a bellows type balanced mechanical seal mounted in an S group standard stuffing box. There is inadequate room in the standard stuffing box to mount a conventional balanced seal requiring a stepped shaft sleeve. Use of these seals requires a remachine of the stuffing box bores.

The following mechanical seals can be installed in standard stuffing boxes by utilizing a remachined, non-pilot gland:

- Crane type 1, 81T, 9T, and Metal Bellows (680)
- Flowserve RO
- Pumps supplied with mechanical seals can be converted to packing. A packing conversion kit is available as shown in Fig. 26. It includes all the standard stuffing box fittings plus a liner sleeve that presses into the oversize stuffing box bore.

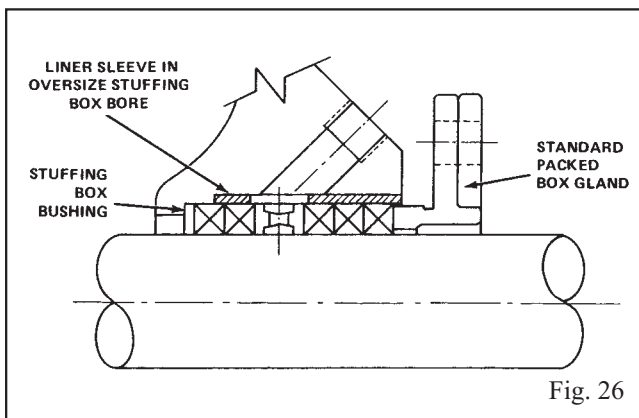

CONNECTION OF SEALING LIQUID (PACKED BOX)

General

If stuffing box pressure is above atmospheric pressure and pumpage is clean, normal gland leakage of 40 to 60 drops per minute is usually sufficient to lubricate and cool packing and sealing liquid is not required.

Clean sealing liquid is required when:

- Abrasive particles in pumpage could score shaft of sleeve.
- Stuffing box pressure is below atmospheric pressure due to pump running with suction lift, or when suction source is under vacuum. Under these conditions, packing will not be cooled and lubricated and air will be drawn into pump.

Sealing Liquid

Sealing liquid may be supplied by recirculation of pumpage through a line from casing to stuffing box. If pumpage is abrasive, an outside source of clean compatible liquid must be used at a pressure of 15 PSI or greater above suction pressure.

4

CONNECTION OF COOLING WATER PIPING TO OPTIONAL PUMP FEATURES

Quench Gland

Tapped openings on top of the quench gland are provided for water sealing. Bypass piping is connected from a "T" installed in vent plug opening at top of upper casing to the tapped opening in the stuffing box.

MECHANICAL SEAL FLUSHING/ COOLING PIPING

 **The mechanical seal must have an appropriate seal flush system. Failure to do so will result in excess heat generation and seal failure.**

 **Sealing systems that are not self purging or self venting, such as plan 23, require manual venting prior to operation. Failure to do so will result in excess heat generation and seal failure.**

Mechanical Seals

For satisfactory operation, there must be a liquid film between seal faces to lubricate them. If liquid flashes to vapor, faces will run dry and be damaged. In general, this requires that liquid be cooled so that vapor pressure is well below stuffing box pressure. Doubtful cases should be referred to Goulds for a recommendation. Refer to seal manufacturer's drawing for location of taps. Some methods which may be used to flush/cool the seal are:

- **Cool Liquid Flushing – External Source.** A clean, cool compatible liquid is injected from an outside source directly into seal gland. Flushing liquid must be at a pressure 5 to 15 PSI greater than pressure in stuffing box. One-half to two GPM (2-8 LPM) should be injected. A control valve and rotometer can be placed in the inlet line to permit accurate regulation.
- **Cool Liquid Flushing – Product Cooling.** In this arrangement, pumped liquid is piped from the pump casing, and is cooled in an external heat exchanger, when required, then injected into seal gland. A control valve and rotometer can be placed in the inlet line to permit accurate regulation.
- **Other piping plans are available.**

CONNECTION OF DRAIN PIPING

Tapped openings around stuffing box for draining leakage are optional. Check assembly dimension print for size and location.

Check rotor for free turning.

 **Rotate shaft by hand to ensure it rotates smoothly and there is no rubbing which could lead to excess heat generation and or sparks.**

PRIMING THE PUMP

 **Pumps must be fully primed at all times during operation.**

 **A build up of gases within the pump, sealing system and or process piping system may result in an explosive environment within the pump or process piping system. Ensure process piping system, pump and sealing system are properly vented prior to operation.**

General

The pump must always be fully primed and suction pipe full of liquid before pump is started.

If pump is run dry, rotating parts within pump may seize to stationary parts since they depend upon liquid being pumped for lubrication.

Several different methods of priming can be used, depending upon type of installation and service involved.

Supply Above Pump

When pump is installed as shown in Fig. 27, pump will prime itself. Open gate valve on suction and close discharge gate valve. Remove vent plug until all air is expelled and water flows through openings. Close air vent valves, start pump, and open discharge gate valve. Pump will continue to be primed for any future starting.

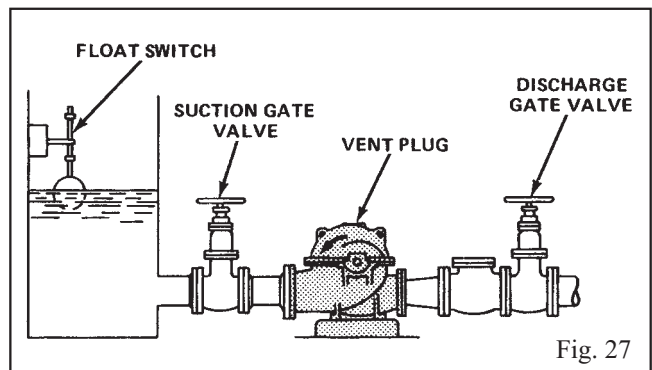

This method is simplest and, particularly for automatic operation, safest. A float switch in suction reservoir can be arranged to stop pump, should there be failure of liquid supply.

Priming with Foot Valve

With pump installed on suction lift, with foot valve at end of suction line, priming can be done any of following three ways:

1. **Outside Supply** (Fig. 28). Close discharge gate valve, remove vent plug, and open valve in priming supply line until all air is expelled and water issues from vent openings. Close air vents, close valve in priming supply line, and start pump; then open discharge gate valve.

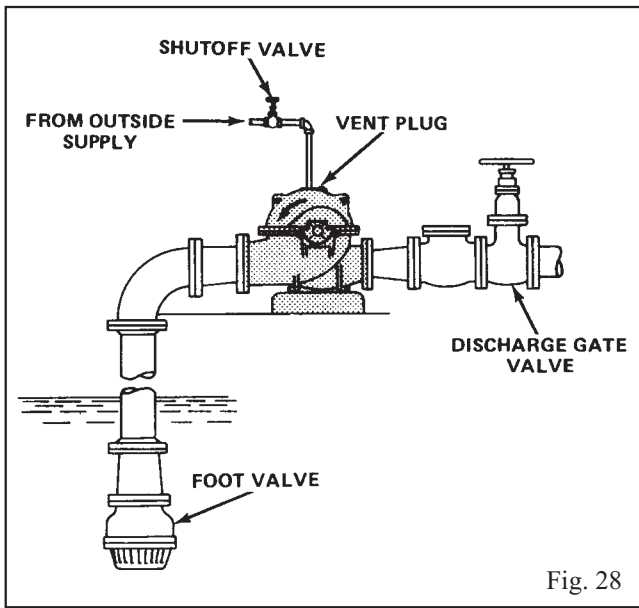

Fig. 28

2. Priming By Separate Hand, or Manually Controlled, Priming Pump (Fig. 29).

- Close discharge gate valve (do not remove vent plug) and open valve in line to priming pump. Exhaust air from pump and suction piping until water flows from priming pump. With priming pump running, close valve in priming line, start pump, and open discharge gate valve.
- An alternate method is to reverse connections on priming pump and extending priming pump suction to source of liquid supply. The pump may be primed by pumping liquid into casing until liquid comes out of open air vent plug removed.

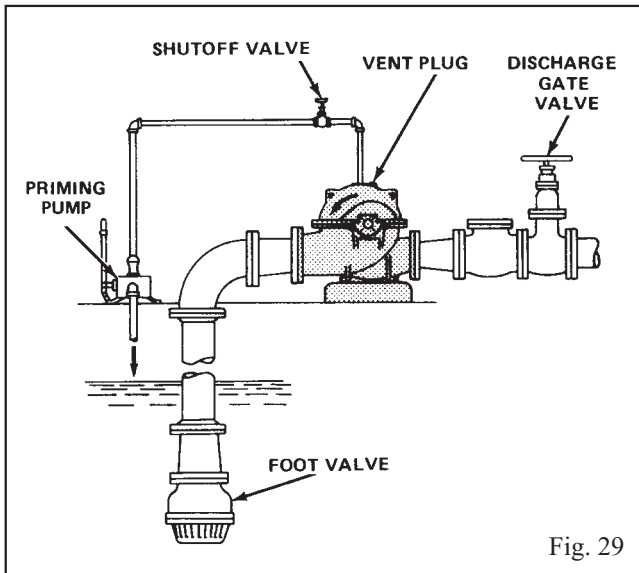

Fig. 29

- In either of these methods (1) and (2), pump will remain primed, provided foot valve is tight. Any failure, however, of foot valve when pump is standing

idle will permit pump to lose its time. During long idle periods, pump can also lose its prime through leakage from stuffing boxes.

3. Bypassing Around Discharge Check Valve (Fig. 30).

This method can be used only when there is liquid under some pressure in discharge line. The original prime must be affected from some outside source. After subsequent idle periods, open air vents and open valve in bypass line around discharge check and gate valves until liquid flows air vent openings. Close air vents and bypass valve, start pump, and open discharge gate valve.

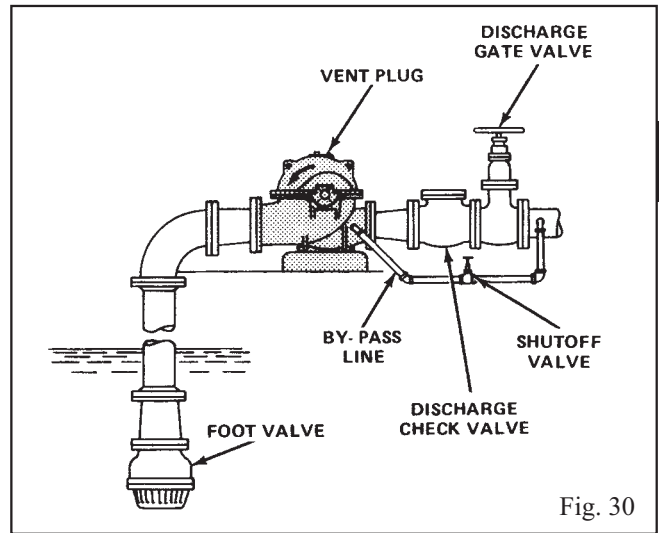
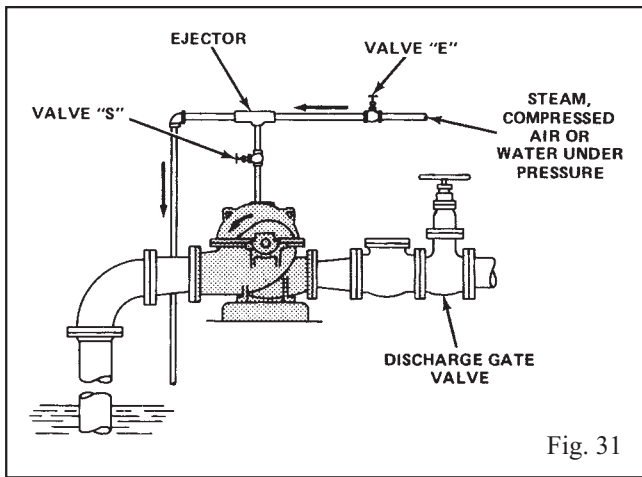

Fig. 30

The valve in bypass can be left open, in which event, during idle periods, loss through foot valve is constantly replenished from discharge line. This system is used for automatic operation where idle periods are of short duration and there is no danger of exhausting all liquid from discharge line, due to a leaky foot valve. Foot valve must be capable of withstanding static head pressure of system.

Priming by Ejection

1. On suction lift installation, an ejector, operated by steam, compressed air, or water under pressure, and connected to tapped opening in top of casing can be used to remove air from casing and suction line, thus priming pump. See Fig. 31.
2. Close discharge gate valve, open valve "E" in steam, air or water pressure supply line. Open valve "S" in suction pipe of ejector connected to pump casing. Air will be evacuated and liquid will be drawn up into suction pipe and pump casing. When all air is evacuated, start pump, close valve "S" and valve "E", and open discharge gate valve.



Priming by Automatic Primer Pump

Where there is a fluctuating suction lift that occasionally might drop below normal limits of pump, or for installations where there is any quantity of air entrained in pumpage, system shown in Fig. 32 is very well adapted.

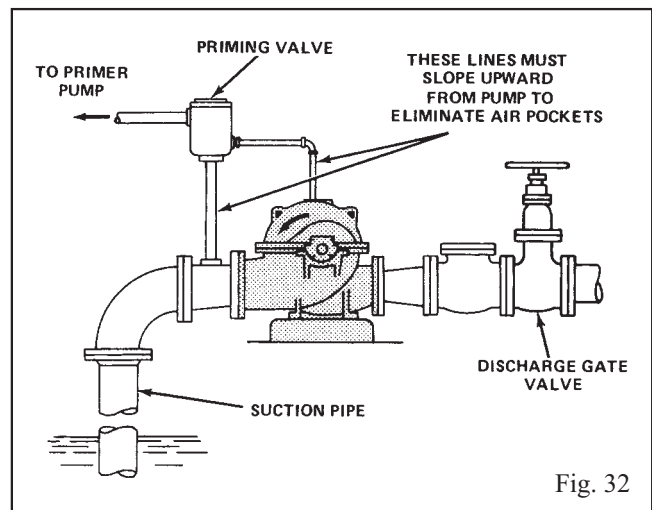

A vacuum tank and a vacuum gauge can be installed near primer pump and vacuum switch set to automatically start or stop primer pump according to vacuum required to keep system primed.

STARTING THE PUMP

1. Make sure suction valve and any recirculation or cooling lines are open.
2. Fully close or partially open discharge valve as dictated by system conditions.
3. Start Driver.



CAUTION

Immediately observe pressure gauges. If discharge pressure is not quickly attained - stop driver, reprime and attempt to restart.

4. Slowly open discharge valve until the desired flow is obtained.



CAUTION

Observe pump for vibration levels, bearing temperature and excessive noise. If normal levels are exceeded, shut down and resolve.

OPERATION

GENERAL CONSIDERATIONS



CAUTION

Always vary capacity with regulating valve in the discharge line. NEVER throttle flow from the suction side.



CAUTION

Driver may overload if the pumpage specific gravity (density) is greater than originally assumed, or the rated flow rate is exceeded.



CAUTION

Always operate the pump at or near the rated conditions to prevent damage resulting from cavitation or recirculation.

OPERATING AT REDUCED CAPACITY



WARNING

DO NOT operate pump below minimum rated flows or with suction and/or discharge valve closed. These conditions may create an explosive hazard due to vaporization of pumpage and can quickly lead to pump failure and physical injury.



CAUTION

Damage occurs from:

1. Increased vibration levels - Affects bearings, stuffing box or seal chamber, and mechanical seal.
2. Increased radial loads - Stresses on shaft and bearings.
3. Heat build up - Vaporization causing rotating parts to score or seize.
4. Cavitation - Damage to internal surfaces of pump

OPERATING AT REDUCED HEAD

On motor driven pumps, when discharge head or pressure is allowed to drop considerably below the rated point for any length of time, the motor should be watched for heating because the pump capacity increases with reduced head, as does horsepower consumption. If this condition is likely to persist, arrangements should be made either to manually or automatically throttle the discharge valve to build up head to a safe point.

OPERATING WITH SURGE CONDITIONS IN LINE

If a pump is installed with a quick closing valve in discharge line that closes when pump is running, dangerous pressure surges may be built up that can cause damage to the pump or line. In services of this kind, some cushioning arrangement must be provided to protect the pumping equipment.

OPERATING UNDER FREEZING CONDITIONS

When exposed to freezing conditions and pump is standing idle, liquid inside the pump should be drained by removing drain plugs in bottom of casing and opening vents at top.

INITIAL INSPECTION AFTER STARTING

Packed Box

With pump running at rated speed, stuffing box gland can be adjusted. Draw gland nuts up evenly and only 1/6 of a turn at a time, allowing sufficient time between adjustments for packing to adjust itself and effect on leakage to be observed. If any sign of heating is evident, shut down the pump and allow the box to cool. Several starts may be necessary before box runs cool. Do not back off the gland nuts on a hot box as this will usually result in leaking between the outer edge of the packing and the stuffing box bore. Remember that it takes newly-installed packing some time to run in and that during this period, frequent attention and careful adjustments are necessary.

Mechanical Seal

The mechanical seal was adjusted at the factory. If the seal leaks slightly when the pump is first started, a few hours run-in will allow the seal to adjust itself.



CAUTION

Never run seal dry. Make sure flush cooling lines, if any, are operating properly.

SHUTDOWN

1. Slowly close discharge valve.
2. Shut down and lock driver to prevent accidental rotation.



WARNING

When handling hazardous and/or toxic fluids, proper personal protective equipment should be worn. If pump is being drained, precautions must be taken to prevent physical injury. Pumpage must be handled and disposed of in conformance with applicable environmental regulations.

FINAL ALIGNMENT



Alignment procedures must be followed to prevent unintended contact of rotating parts. Follow coupling manufacturer's coupling installation and operation procedures.

1. Run the unit under actual operating conditions for a sufficient length of time to bring the pump and driver and associated system up to operating temperature.

2. Remove coupling guard.
3. Check alignment while unit is still hot per alignment procedure in the *Installation* Section.
4. Reinstall coupling guard.

PREVENTIVE MAINTENANCE

| | |
|--|-----------|
| GENERAL MAINTENANCE AND PERIODIC INSPECTION | 35 |
| MAINTENANCE TIMETABLE | 35 |
| MAINTENANCE OF FLOOD DAMAGED PUMPS | 36 |
| LUBRICATION | 37 |
| Grease Lubrication | 37 |
| Oil Lubrication | 37 |
| Lubricant Recommendations | 37 |
| Initial Oil Lubrication of New Bearings. | 38 |
| Bearing Temperatures | 38 |
| Emergency Ball Bearing Replacement | 38 |
| Bearing Conditions | 38 |
| Coupling Lubrication | 39 |
| SEALING INFORMATION. | 39 |
| Packing (Non-Asbestos). | 39 |
| Mechanical Seals | 39 |
| Troubleshooting | 40 |

GENERAL MAINTENANCE and PERIODIC INSPECTION

 *The Preventive Maintenance section must be adhered to in order to keep the applicable ATEX classification of the equipment. Failure to follow these procedures will void the ATEX classification for the equipment.*

Operating conditions vary so widely that to recommend one schedule of preventive maintenance for all centrifugal pumps is not possible. Yet, some sort of regular inspection must be planned and followed. We suggest a permanent record be kept of the periodic inspections and maintenance performed on your pump. This recognition of maintenance procedure will keep your pump in good working condition and prevent costly breakdowns.

One of the best results to follow in the proper maintenance of your centrifugal pump is to keep a record of actual

operating hours. Then, after a predetermined period of operation has elapsed, the pump should be given a thorough inspection. The length of this operating period will vary with different applications, and can only be determined from experience. New equipment, however, should be examined after a relatively short period of operation. The next inspection period can be lengthened somewhat. This system can be followed until a maximum period of operation is reached which should be considered the operating schedule between inspections.

INSPECTION INTERVALS

 *Inspection intervals should be shortened appropriately if the pumpage is abrasive and/or corrosive, or if the environment is classified as potentially explosive.*

MAINTENANCE TIMETABLE

EVERY MONTH

Check bearing temperature with a thermometer, not by hand. If bearings are running hot (over 180° F), it may be the result of too much or too little lubricant. If changing the lubricant and/or adjusting to proper level does not correct the condition, disassemble and inspect the bearings.

EVERY 3 MONTHS

Check the oil on oil lubricated units. Check grease lubricated bearings for saponification. This condition is usually caused by the infiltration of water or other fluid and can be noticed immediately upon inspection, since it gives the grease a whitish color. Wash out the bearings with a clean industrial solvent and replace the grease with the proper type as recommended.

EVERY 6 MONTHS

Check the packing and replace if necessary. Use the grade recommended. Be sure the seal cages are centered in the stuffing box at the entrance of the stuffing box piping connection.

Take vibration readings on the bearing housings. Compare the readings with the last set of readings to check for possible pump component failure (e.g. bearings).

Check shaft or shaft sleeve for scoring. Scoring accelerates packing wear.

Check alignment of pump and driver. Shim up units if necessary. If misalignment reoccurs frequently, inspect the entire piping system. Unbolt piping at suction and discharge flanges to see if it springs away, thereby indicating strain on the casing. Inspect all piping supports for soundness and effective support of load. Correct as necessary.

EVERY YEAR

Remove the upper half of the casing. Inspect the pump thoroughly for wear, and order replacement parts if necessary.

Check wear ring clearances. Replace when clearances become three (3) times their normal clearance or when a significant decrease in discharge pressure for the same flow rate is observed.

See Disassembly & Reassembly Section for standard clearances.

Remove any deposit or scaling. Clean out stuffing box piping.

Measure total dynamic suction and discharge head as a test of pump performance and pipe condition. Record the figures and compare them with the figures of the last test. This is important, especially where the fluid being pumped tends to form a deposit on internal surfaces. Inspect foot valves and check valves, especially the check valve which safeguards against water hammer when the pump stops. A faulty foot or check valve will reflect also in poor performance of the pump while in operation.

NOTE: The above timetable is based on the assumption that after startup, the unit has been constantly monitored and such a schedule was found to be consistent with operation, as shown by stable readings. Extreme or unusual applications or conditions should be taken into consideration when establishing the maintenance intervals.

MAINTENANCE OF FLOOD DAMAGED PUMPS

The servicing of centrifugal pumps after a flooded condition is a comparatively simple matter under normal conditions.

Bearings are a primary concern on pumping units. First, dismantle the frame, clean and inspect the bearings for any rusted or badly worn surfaces. If bearings are free from rust and wear, reassemble and relubricate them with one of the recommended lubricants. Depending on the length of time the pump has remained in the flooded area, it is unlikely that bearing replacement is necessary; however, in the event that rust or worn surfaces appear, it may be necessary to replace the bearings.

Next, inspect the stuffing box, and clean out any foreign matter that might clog the box. Packing that appears to be worn, or no longer regulates leakage properly should be replaced. Mechanical seals should be cleaned and thoroughly flushed.

Couplings should be dismantled and thoroughly cleaned. Lubricate the coupling with one of the coupling manufacturer's recommended lubricants where required.

Any pump that is properly sealed at all joints and connected to both the suction and discharge should exclude outside liquid. Therefore, it should not be necessary to go beyond the bearings, stuffing box, and coupling when servicing the pump after flood damage.

LUBRICATION



Throughout this section on bearing lubrication, different pumpage temperatures are listed. If the equipment is ATEX certified and the listed temperature exceeds the applicable value shown in Table 1 under SAFETY, then that temperature is not valid. Should this situation occur, please consult with your ITT/Goulds representative.

GREASE LUBRICATION

Grease lubricated ball bearings are standard on all Model 3410 pumps. These units can be identified by grease fittings located on the bearing housing.

- Grease should be of sodium or lithium base, NLGI #2 consistency. DO NOT USE GRAPHITE.
- It is suggested that additional or replacement lubricant be added after 2,000 hours or at three-month intervals.
- Lubricant should be renewed in housings at least once annually. This should be done when an overhaul is made.
- To grease bearings, proceed as follows:



CAUTION

Grease lubricated bearings are lubricated at the factory. Do not grease at too frequent intervals.

1. Remove relief plug (1) on bearing housing. See Fig. 33.
2. Insert grease through fitting (2) until grease appears through relief plug hole.

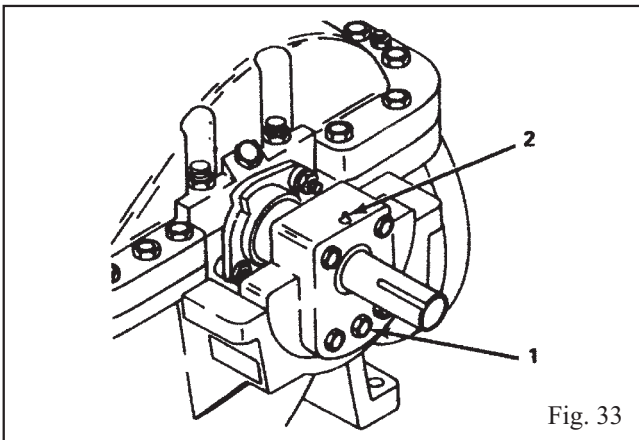

Fig. 33

3. Repeat steps 1 and 2 on other bearing.
4. Operate unit approximately 1/2 hour with relief holes open to prevent overgreasing. After 1/2 hour, replace relief plugs on both bearing housings.

OIL LUBRICATION

Flood oil lubricated ball bearings are optional on all Model 3410 units. Oil lubricated pumps are supplied with oilers which maintain a constant oil level in the bearing housing.



CAUTION

Under normal operating conditions, an oil of 300 SSU viscosity at 100°F (38°C) (approximately SAE-20) should be used, (see lubricant recommendations below). For extreme conditions refer to the factory or a lubrication expert for a recommendation.

Fill auto oiler bottles on both bearing housings with the proper grade of oil and place on oiler housing. Oil reservoir in bearing housing is filled when a constant oil level remains in the bottle. Several fillings of bottle are required for initial lubrication. Never fill through the oiler housing without use of the oiler bottle.

LUBRICANT RECOMMENDATIONS

The following have been recommended by various suppliers as meeting their basic requirements:

| | |
|--------------|---|
| EXXON | TERESSTIC 68 |
| CHEVRON | GTS OIL 68 |
| MOBIL | MOBIL DTE 26 300 SSU @ 100°F |
| PHILLIPS | MANGUS OIL GRADE 315 |
| TEXACO | BELOW 80°F: REGAL OIL R&O-46 #10 WEIGHT ABOVE 80°F: REGAL OIL R&O-46 #20 WEIGHT |
| SHELL | 32° TO 150°: TELLUS OIL 68 -20° TO 32°: TELLUS OIL 23 150° TO 200°: TURBO OIL 150 |
| ROYAL PURPLE | SYNFILM 150 VG 68 SYNTHETIC LUBE |

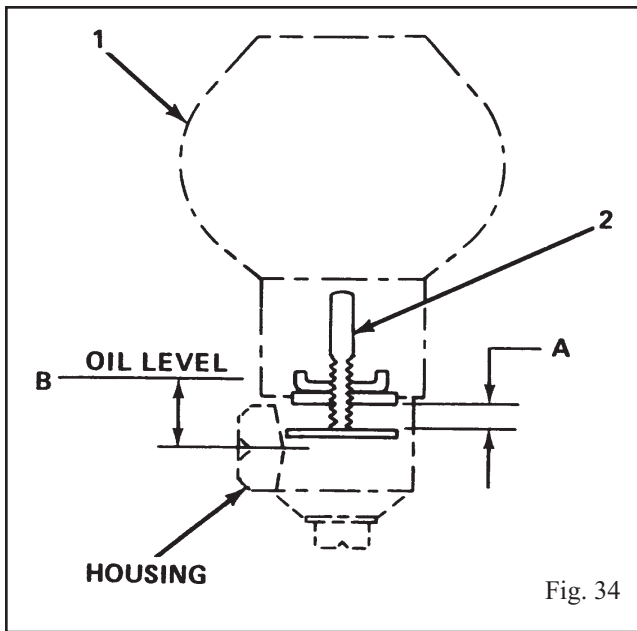

INITIAL OIL LUBRICATION OF NEW BEARINGS

1. Remove oiler (1), Fig. 34.
2. Remove adjustment assembly (2) from oiler.
3. Adjust bars to dimension A, as required, Table 4.
4. Lock in position.
5. Replace adjustment assembly in oiler.
6. Install oiler.

NOTE: Never fill through oil vent or oiler housing.

7. Fill each oiler bottle with oil and replace in oiler housing. Oil reservoir in bearing housing is filled when oil remains visible in bottle. Several fillings of bottle may be required.



CAUTION

Bar adjust must be adjusted as stated in step 3 above. If not adjusted properly, bearing will not be lubricated.

Table 4

| GROUP | A in. (mm) | B in. (mm) | OILER SIZE oz. (ml) | CASING CAPACITY ounces (ml) |
|--------|---------------|---------------|---------------------------|-----------------------------------|
| S & M | 9/16 (14.5) | 1/2 (13) | #5 - 8 (204) | 9 (266) |
| L & XL | 9/16 (14.5) | 1/2 (13) | #5 - 8 (204) | 16-1/2 (489) |

BEARING TEMPERATURES

All bearings operate at some temperature above that of the surrounding atmosphere, unless cooled. Heat is generated within the bearing due to rolling friction, churning of oil, and the drag of the race.

Do not use the human hand as a thermometer. A temperature which feels hot varies from 120°F (49°C) to 130°F (54°C) depending upon the individual. Above this temperature, the human hand is worthless in estimating temperature.

Bearing temperatures up to 180°F (82°C) are normal. Determine the temperature accurately by placing a contact type thermometer against the bearing housing. It should be recorded in a convenient location for reference. The stability of the temperature, rather than the number of degrees, is the best indication of normal operation. A sudden increase in temperature is an indication of danger and a signal to investigate. The unit should be checked for abnormal hydraulic operation and unnecessary loads, such as coupling misalignment, etc. See Troubleshooting.

EMERGENCY BALL BEARING REPLACEMENT

If the outboard end ball bearing needs replacement and it is not desirable to overhaul the entire pump, the bearing can be replaced without disassembling the entire pump. See Disassembly and Reassembly section for details.



WARNING

Lock out power driver before starting this procedure to prevent accidental turning.

NOTE: Coupling end bearing cannot be replaced in this manner unless pump or driver is removed from bedplate or spacer coupling is used.

BEARING CONDITIONS

The life of a bearing can be drastically reduced if contaminated with even a small amount of dust or dirt. All bearing assembly operations should be done in as dust-free an atmosphere as possible. All tools, as well as hands, should be kept clean.

If new bearings are to be installed, they should not be unwrapped, cleaned, or washed until ready for installation.

If old bearings are contaminated, they should be replaced. Washing bearings does not guarantee cleanliness and is risky at best. If new bearings are not readily available and immediate reassembly is necessary, contaminated bearings can be cleaned as follows:

1. Pour one or two quarts of clean, water-free kerosene into a clean pail. Dip the bearings into kerosene and agitate slowly.

2. Blow dry with clean, filtered compressed air. Hold the two races together, but allow the inner race to rotate a few turns now and then to dislodge the kerosene from the retainer pockets.
3. When bearing has been blown dry, oil immediately with a good grade of clean machine oil to prevent corrosion or rust.

If there is any question as to the condition of bearings, it is always best to replace them. This may prevent an unplanned shutdown.

Check bearing housing seals and replace as required.

COUPLING LUBRICATION

Grid or gear tooth couplings (Falk Grid Steelflex or Falk Crowned Tooth coupling for instance) are initially lubricated with Falk Long Term Grease (LTG) and do not require relubrication for up to three years. If coupling leaks grease, or is exposed to extreme temperatures or excessive moisture, more frequent lubrication may be required.

Use coupling manufacturer's recommended grease to provide trouble free performance.

Flexible couplings (Wood's Sure-Flex or Falk Torus coupling for instance) provide smooth transmission of power. There is no rubbing action of metal against rubber to cause wear. Couplings are not affected by abrasives, dirt or moisture. This eliminates the need for lubrication or maintenance, and provides clean and quiet performance.

If other types of couplings are used, follow maintenance instructions of coupling manufacturer.

SEALING INFORMATION

PACKING (NON-ASBESTOS)

When a pump with fiber packing is first started it is advisable to have the packing slightly loose without causing an air leak. As the pump runs in, gradually tighten the gland bolts evenly. The gland should never be drawn to the point where packing is compressed too tightly and no leakage occurs. This will cause the packing to burn, score the shaft sleeve and prevent liquid from circulating through the stuffing box cooling the packing. The stuffing box is improperly packed or adjusted if friction in the box prevents turning the rotating element by hand. A properly operated stuffing box should run lukewarm with a slow drip of sealing liquid. After the pump has been in operation for some time, and the packing has been in operation for some time, and the packing has been completely run-in, drippage from the stuffing boxes should be at least 40 to 60 drops per minute. This will indicate proper packing and shaft sleeve lubrication and cooling.

NOTE: Eccentricity of the shaft or sleeve through the packing could result in excess leakage that cannot be compensated for. Correction of this defect is very important.

Packing should be checked frequently and replaced as service indicates. Six months might be a reasonable expected life, depending on operating conditions. It is impossible to give any exact predictions. A packing tool should be used to remove all old packing from the stuffing box. Never reuse old and lifeless packing or merely add some new rings. Make sure the stuffing box is thoroughly cleaned before new packing is installed. Also check the condition of the shaft or sleeve for possible scoring or eccentricity, make replacements where necessary.

New packing (non-asbestos) should be placed carefully into the stuffing box. If molded rings are used, the rings should be opened sideways and the joints pushed into the stuffing box first. The rings are installed one at a time, each ring seated firmly and the joints staggered at about a 90° rotation from each preceding joint.

MECHANICAL SEALS

General instructions for operation of the various mechanical sealing arrangements are included below. It is not feasible to include detailed instructions for all mechanical seals in this booklet because of the almost unlimited number of possible combinations and arrangements. Instead, seal manufacturer's instructions will be included as a separate supplement to this book, where required.

- a. Mechanical seals are precision products and should be treated with care. Use special care when handling seals. Clean oil and clean parts are essential to prevent scratching the finely lapped sealing faces. Even light scratches on these faces could result in leaky seals.
- b. Normally, mechanical seals require no adjustment or maintenance except routine replacement of worn or broken parts.
- c. A mechanical seal which has been used should not be put back into service until the sealing faces have been replaced or relapped. (Relapping is generally economical only in seals two inches in size and above.)

Four important rules which should always be followed for optimum seal life are:

1. Keep the seal faces as clean as possible.
2. Keep the seal as cool as possible.
3. Assure that the seal always has proper lubrication.
4. If seal is lubricated with filtered fluid, clean filter frequently.

TROUBLESHOOTING

INTRODUCTION

The troubleshooting table lists common malfunctions, which you may find during the operation or maintenance of the Model 3410. You should perform tests/inspections and corrective actions in the order listed.

This manual cannot list all malfunctions, tests, inspections, or corrective actions that may occur. If a malfunction is not listed or is not corrected by listed corrective actions, contact your Goulds representative.

Use the following symptom index to locate troubleshooting procedures.

1. The Symptom column identifies the most common malfunctions.
2. The adjacent Cause and Correction Key identifies possible causes and corrective measures listed in the troubleshooting table for each malfunction.

SYMPTOM INDEX

| Symptom | Cause and Correction Key |
|--|---|
| No liquid delivered, not enough liquid delivered, or not enough pressure | 1, 2, 3, 4, 5, 6, 7, 8, 9, 10, 11, 12, 13, 14, 18, 19 |
| Pump works awhile and then quits | 4, 5, 7, 8, 9, 11, 12, 20 |
| Pump takes too much power | 6, 14, 15, 16, 21, 22, 23, 24, 30, 31, 32 |
| Pump is noisy or vibrates | 15, 16, 17, 28, 30 |
| Pump leaks excessively at stuffing box | 16, 17, 30 |
| High bearing temperature | 16, 17, 30, 32, 36 |
| Stuffing box overheating | 8, 24, 25, 26, 27, 35 |
| Element turns hard or has a rub | 16, 31, 32, 33, 34 |

Troubleshooting Table

| Key | Cause | Corrective Measures |
|-----|---|---|
| 1 | Pump not primed or properly vented. | Check that casing and suction pipe are completely filled with liquid. |
| 2 | Speed too low. | Check whether motor wiring is correct and receives full voltage or turbine receives full steam pressure. |
| 3 | System head too high | Check system head (particularly friction losses). |
| 4 | Suction lift too high. | Check NPSH Available (suction piping too small or long may cause excessive friction losses). Check with vacuum or compound gauge. |
| 5 | Impeller or piping obstructed. | Check for obstructions. |
| 6 | Wrong direction of rotation. | Check rotation. |
| 7 | Air product or leak in suction line. | Check suction piping for air pockets and/or air leaks. |
| 8 | Stuffing box packing or seal worn allowing leakage of air into pump casing. | Check packing or seal and replace as required. Check for proper lubrication. |
| 9 | Not enough suction head for hot or volatile liquids. | Increase suction head, consult factory. |
| 10 | Foot valve too small. | Install correct size foot valve. |
| 11 | Foot valve or suction pipe not immersed deep enough. | Consult factory for proper depth. Use baffle to eliminate vortices. |
| 12 | Entrained air or gases in liquid. | Consult factory. |
| 13 | Impeller clearance too great. | Check for proper clearance. |
| 14 | Impeller damaged. | Inspect and replace as required. |
| 15 | Rotating parts bind. | Check internal wearing parts for proper clearances. |
| 16 | Shaft bent. | Straighten or replace as required |
| 17 | Coupling or pump and driver misaligned. | Check alignment and realign if required. |
| 18 | Impeller diameter too small. | Consult factory for proper impeller diameter. |
| 19 | Improper pressure gauge location. | Check correct position and discharge nozzle or pipe. |
| 20 | Casing gasket damaged. | Check gaskets and replace as required. |
| 21 | Speed too high. | Check motor winding voltage or steam pressure received by turbines. |
| 22 | Head lower than rating, pumps too much liquid. | Consult factory. Install throttle valve and cut impeller. |
| 23 | Liquid heavier than anticipated. | Check specific gravity and viscosity. |

Troubleshooting Table

| Key | Cause | Corrective Measures |
|-----|--|---|
| 24 | Stuffing box not properly packed (insufficient packing, not properly inserted or run in, packing too tight). | Check packing and repack stuffing box. |
| 25 | Incorrect packing or mechanical seal. | Consult the factory. |
| 26 | Damaged mechanical seal. | Inspect and replace as required. Consult factory. |
| 27 | Shaft sleeve scored. | Remachine or replace as required. |
| 28 | Cavitation. | Increase NPSH Available. Consult factory. |
| 29 | Pump capacity too low. | Consult factory for minimum continuous flow. |
| 30 | Improper bearing lubrication or bearings worn out. | Inspect and replace as required. |
| 31 | Improper running clearances between wear rings. | Check for proper clearance. Replace casing and/or impeller wear rings as required. |
| 32 | Excessive pipe strain on pump casing. | Relieve strain and consult your Goulds representative. Check alignment after strain is relieved. |
| 33 | Excessive runout on shaft or impeller rings. | Inspect rotating element and bearings. Replace worn or damaged parts as required. |
| 34 | Dirt between impeller and casing wear rings. Dirt in casing ring. | Clean and inspect wear rings. Replace as required. Isolate and relieve source of dirt. |
| 35 | Packing too tight or mechanical seals not properly adjusted. | Check and adjust packing, replace as required. Adjust mechanical seals, refer to manufacturer's instructions supplied with pump, or consult factory |
| 36 | Excessive lubrication. | Take out the relief plug to allow the excess grease to purge itself. If unit is oil lubricated, drain the oil to the correct level. |

DISASSEMBLY & REASSEMBLY

| | |
|-----------------------|----|
| DISASSEMBLY | 43 |
| INSPECTION | 45 |
| REASSEMBLY. | 47 |



Leakage of process liquid may result in creating an explosive atmosphere. Follow all pump and seal assembly procedures.

DISASSEMBLY



WARNING

Pump components can be heavy. Proper methods of lifting must be employed to avoid physical injury and/or equipment damage. Steel toed shoes must be worn at all times.



WARNING

The pump may handle hazardous and/or toxic fluids. Proper personal protective equipment should be worn. Precautions must be taken to prevent physical injury. Pumpage must be handled and disposed of in conformance with applicable environmental regulations.

NOTE: Before disassembling the pump for overhaul, ensure all replacement parts are available.



WARNING

Lock out power supply to driver motor to prevent accidental startup and physical injury.

1. Shut off all valves controlling flow to and from pump.



WARNING

Operator must be aware of pumpage and safety precautions to prevent physical injury.

2. Drain liquid from pump, flush pump if necessary.
3. Disconnect all auxiliary tubing and piping.
4. Remove coupling guard.
5. Disconnect coupling.
6. If the unit is oil lubricated, remove reservoir bottle and oil drain plugs from bottom of bearing housings and drain oil. Replace plugs after draining.
7. Remove glands from casing. If unit has packed stuffing

boxes, remove nut from stud and remove gland halves. If equipped with mechanical seals, slide glands toward bearings. Protect lapped stationary seat faces from damage.

8. Remove casing screws (426) and nuts (425). Remove Dowel Pins (469G). Loosen top half by:
 - S Group – Insert a prying tool into parting slot, Fig. 35, pry upper casing half loose. Repeat on other side as required.
 - M Group L and XL – Tighten two jacking bolts (418) (Fig. 36) evenly until seal is broken.

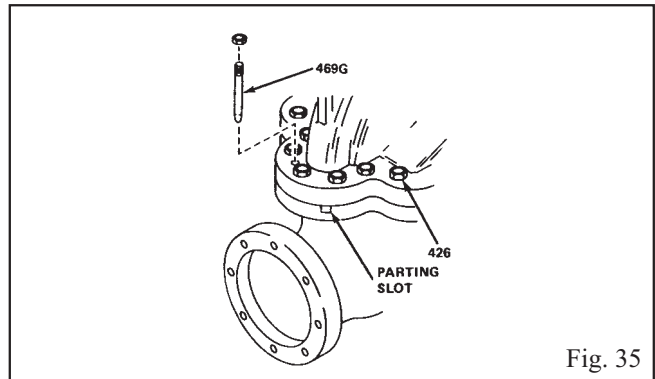

Fig. 35

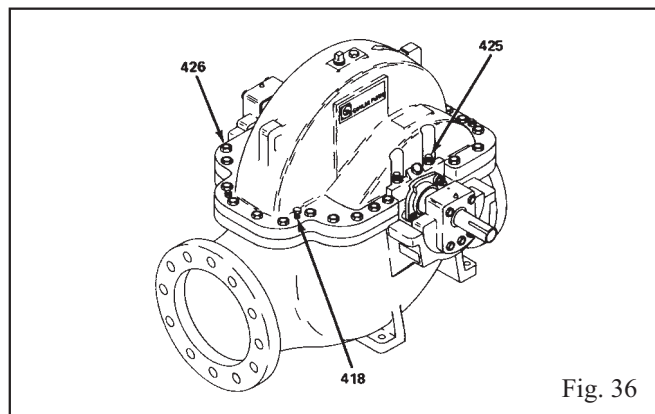

Fig. 36

NOTE: Refer to Fig. 38 and 39 at the end of this chapter for illustrated detail of the following procedures.



WARNING

Never attempt to lift entire pump using lifting lugs.

9. Remove upper casing using sling and hoist or lift and lifting lugs. Remove and discard gaskets.
10. Remove screws (372U) from bearing saddle.
11. Place sling on shaft (122). Using suitable hoist or lift, remove rotating element and place on padded supports. On units with mechanical seals, care should be taken to insure the casing rings (103) do not slip and damage the seals.
12. Mark coupling position on shaft (122) and remove coupling (see manufacturer's instructions).
13. Bearing removal.
 - a. Remove screws (371C). Slide housings (134) off bearing (168 and 112) and shaft (122). Use care not to damage oil seal (332).
 - b. Using snap ring pliers, remove retaining ring (361) from thrust end of shaft.



CAUTION

Never use a hammer to drive shaft through bearings. Doing so can cause severe shaft and bearing damage.

- c. Remove bearings (168 and 112) using bearing puller. Use care not to damage bearings. If bearing is to be reinstalled, protect from contamination by wrapping with a clean cloth or paper.

(S Group only). Use a two-jaw puller on end cover (109). When pulling bearing, use caution not to damage end cover.

(M, L, and XL Groups). Use split jaw puller on back of bearing (168 and 112).

Discard old bearings.

NOTE: Bearing replacement is recommended whenever bearings are removed from the shaft.

(L and XL Groups). Remove radial bearing spacer (443T).

- d. Remove gaskets (360), bearing end covers (109), and deflectors (123). Discard gasket.
 - e. Remove outboard seal (332) from coupling end bearing housing, and inboard seal (333) from each end cover (109).
14. If unit has mechanical seals (not shown), slide glands with stationary seat in place off shaft. Use care to

prevent damage to lapped seal faces. If unit has packed stuffing boxes, remove nuts (355), gland (107), packing (106), lantern rings (105), and stuffing box bushings (125).

15. Slide casing wear ring (103) off impeller and shaft.
16. Remove rotary portion of both seals.
17. Remove shaft sleeves (126):
 - a. When removing sleeve (126), use very fine emery cloth to smooth shaft. This prevents binding.

NOTE: Optional shaft sleeve on S group should only be removed when replacement is required.

- b. S Group (sleeve option, Fig. 39). Loosen sleeve (126) with low heat (350-400°F) (177-222°C) (use temperature stick, etc. to monitor the temperature), apply torque with strap wrench, slide sleeve carefully off shaft.
- c. M, L, XL Group (Fig. 38):
 - Loosen set screw (222B) on sleeve nut (124).
 - Using spanner or strap wrench, unscrew sleeve nut (124).
 - Remove and discard O-rings (497).
 - Carefully slide sleeves (126) off shaft.
 - Remove and discard sleeve to impeller gasket (428) located on end of sleeve nearest impeller.

18. Remove impeller.
 - a. S Group (Fig. 39).
 - Using snap ring pliers, remove retaining rings (361H).
 - Drive or press impeller (101) off shaft.
 - Remove key (178).
 - b. M, L, XL Groups



CAUTION

Do not damage impeller hub surface which is sealed by sleeve gasket.

- Scribe a mark on the shaft to mark the location of the impeller hub.
- Drive or press impeller (101) off shaft.
- Remove key (178)

INSPECTION

O-RINGS

Inspect O-rings (497) and replace if damaged (M, L, XL Groups only).

WEAR RINGS

The original radial clearance between the impeller and the casing wear rings is shown in Fig. 37 and Table 5. When hydraulic performance is reduced substantially, the casing rings should be replaced.

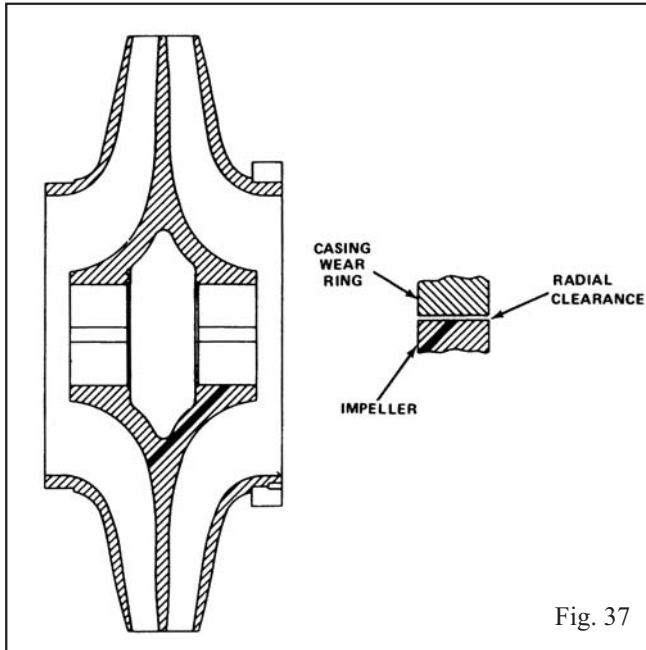

Fig. 37

Table 5
RADIAL CLEARANCE

| Group | Pump | Iron & Bronze | Steel |
|-------|-------------------------------|-------------------------------------|----------------------------------|
| S | 2x3-11 | | |
| | 3x4-10 | | |
| | 4x6-9 | | |
| | 4x6-11 | .005 - .007" (.013 - .018 mm) | .009 - .011" (.022 - .028 mm) |
| | 4x6-11H | | |
| | 4x6-13 4x6-13H | | |
| M | 4X6-15 | | |
| | 6x8-11 | | |
| | 6x8-14 | | |
| | 6x8-14H | .005 - .007" (.013 - .018 mm) | .009 - .011" (.022 - .028 mm) |
| | 6x8-17 | | |
| | 8x10-11 8x10-12 8x10-14 | | |
| L | 6X8-22 | | |
| | 6x10-17 | .005 - .007" (.013 - .018 mm) | .009 - .011" (.022 - .028 mm) |
| | 8x10-17 | | |
| | 8x10-17H | .0055 - .0075" (.014 - .019 mm) | .010 - .012" (.025 - .030 mm) |
| | 8x10-21 | .005 - .007" (.013 - .018 mm) | .009 - .011" (.022 - .028 mm) |
| | 10x12-12 | .0055 - .0075" (.014 - .019 mm) | .010 - .012" (.025 - .030 mm) |
| XL | 10x12-14 | .005 - .007" (.013 - .018 mm) | .010 - .012" (.025 - .030 mm) |
| | 10x12-17 | .0065 - .0085" (.017 - .022) mm) | .011 - .013" (.028 - .033 mm) |
| | 10x12-12H | .0055 - .0075" (.014 - .019 mm) | .010 - .012" (.025 - .030 mm) |
| | 10x12-15 | | |
| | 12x14-15 | .0065 - .0085" (.017 - .022) mm) | .011 - .013" (.028 - .033 mm) |

IMPELLER WEAR RINGS (OPTIONAL)

If the unit has impeller wear rings (142) and it is necessary to replace rings (Fig. 38), proceed as follows:

NOTE: If impeller was supplied without wear rings and excessive wear requires, wear rings may be fitted in the field. Fitting wear rings will require remachining of impeller. Contact your local Goulds representative for details.

1. Remove old rings by removing three set screws (320) and pulling ring (142) off impeller hub.
2. Clean hub and press on new ring (142).
3. Drill and tap three holes 120 degrees (1600 mils) apart with 7/32 drill and 1/4" - 20NC tap on each ring. Use 5/16" x 1/4" cup point safety set screws. Tighten screws and lightly upset threads. Do not use existing holes.

GASKET

Inspect parting gaskets (331). If torn or otherwise damaged, cut a new gasket of 1/32" (.8 mm) non-asbestos (see recommendations below). Use upper half casing as a template. Strike the sheet with a soft face hammer. This will cut the gasket against the edge of casing. The gasket must cover entire surface of the parting flange, especially around wear ring locks and stuffing box, or internal leakage from high to low pressure zones in pump will occur.

The following gasket materials are recommended if pre-cut replacement gaskets are not available:

Recommended Gasket Material

NOTE: Gasket thickness is 1/32".

- JM - 961
- Durable - Durlon
- Garlock Blue Guard 3000
- Armstrong - N8090
- Rodgers - D7031
- Or equivalent.

SHAFT

Check shaft (122) for runout to see that it is not bent. Straighten if required. Bearing seats must be in perfect condition. Replace shaft if necessary. Check keyways for burrs or foreign matter.

IMPELLER

Check impeller (101) and replace if there is:

- Excessive erosion, especially on inlet vanes.
- Gasket mating surface deterioration to point that gasket (428) cannot seal properly.

- Excessive erosion of surfaces. If impeller diameter has to be cut, it should be dynamically balanced. Imbalance can be corrected by grinding outside of shrouds near periphery.

SHAFT SLEEVE

The sleeve (126) surface in the stuffing box area must be smooth and free of grooves. If grooved, replace. O-ring groove in end of sleeve nut must be in good condition. Impeller end of sleeve must be in good condition to ensure gasket (428) will seal properly. The original diametric clearance between shaft sleeve and the stuffing box bushing is 0.030 - 0.034" (.76 - .86 mm). If this clearance has increased to more than 0.050 - 0.060" (1.27 - 1.5 mm) the sleeve, and at times, the stuffing box bushing, should be replaced.

BEARINGS

Ball bearings (112 and 168) can be checked for visible wear by slowly turning races and watching for pits or worn areas on balls or raceways. Bearings can also be inspected by holding inner race and spinning outer race. If any rasping noises are emitted or bearing catches or binds, it should be replaced. If any wear on race is apparent, replacement is suggested.

Replace ball bearings if worn, loose, rough, or noisy when rotated.

SEALS

Check seals (332 and 333) for wear, cracks, cuts, deformities, and signs of excessive leakage. Check thrust bearing end cover (109A) for signs of leakage and damage. Check grease fittings (113) or oil breathers (113A) (oil option) for serviceability, replace as required.

GENERAL

All parts should be cleaned before assembly. This is especially important at O-ring grooves, mating surfaces and bearing areas. Threads on dowels, screws, nuts, and studs should be in good condition. Ensure anti-rotation pins (445A) are firmly pressed into wear rings (103).

NOTE: See preventive Maintenance for specific instruction for bearing cleaning.

REASSEMBLY

 **Check for magnetism on the pump shaft and degauss the shaft if there is any detectable magnetism. Magnetism will attract ferritic objects to the impeller, seal and bearings which can result in excess heat generation, sparks and premature failure.**

- Insert key (178) in shaft (122).
- Determine correct positioning of impeller (101) on shaft (122). Facing coupling end of shaft, determine proper rotation of unit (clockwise or counterclockwise). Fig. 3-6 shows proper relationship between rotation and impeller vane curvature for counterclockwise rotation.

S Group – Install retaining ring (361H) in inboard (coupling end) retaining groove.

Slide impeller (101) on shaft. On S Group, drive impeller flush with retaining ring (361H).



CAUTION

Do not damage end of shaft.

If same shaft and impeller are used, line up impeller hub with scribe mark made on shaft during disassembly.

- Group M, L, XL Only (for S Group go to step 5) – Place sleeve to impeller gasket (428) on impeller (101). Ensure gasket is aligned with key (178).
- Groups M, L, XL Only
 - a. Slide sleeve (126) on shaft.
 - b. Slide O-rings (497) on shaft by stretching over threaded end of shaft.
 - c. Using spanner or strap wrench tighten sleeve nuts (124), adjusting impeller to approximate center. Do not tighten set screw. Additional impeller adjustment will be required when rotating element is placed in casing.

 **The impeller and wear ring clearance setting procedures must be followed. Improperly setting the clearance or not following any of the proper procedures can result in sparks, unexpected heat generation and equipment damage.**

- S Group Only – Install impeller retaining ring (361H) as follows:

Outboard (thrust end) retaining ring groove and retaining ring (361H) are tapered (see Fig. 39). Install retaining ring so that tapered side is facing outboard end of shaft. Inward pressure asserted by double taper provides automatic centering of impeller, and eliminates lateral play.

- S Group with optional sleeve only – Ensure shaft is free of dirt, grease, and bonding compounds. Apply a thin coat of Loctite 635, or equal, to shaft sleeve area and inside of sleeve. Slide sleeve on outboard end of shaft, make sure sleeve is firmly seated against shaft shoulder.
- Position casing wear rings (103) on impeller, ensure anti-rotation pins (445A) are firmly seated.
- Slide stuffing box bushing (125) on shaft or sleeve. (Units with mechanical seals do not have a stuffing box bushing.) If unit is equipped with mechanical seals, install seals at this time. Refer to manufacturer's instructions for details.
- Slide deflectors (123), bearing end covers (109), and gaskets (360) on shaft.
- Install bearings as follows:
 - a. Apply a thin film of machine oil to bearing seats on shaft.
 - b. Start bearings (112 and 168) on shaft by tapping inner race with a hammer or mallet, keeping bearing square at all times.
 - c. Once bearing is started on shaft, a driving sleeve should be used. Sleeve should contact only 1 inner race. Press or drive bearing until it contacts shoulder on inboard side of seal.
 - d. For outbound or thrust bearing. Install tapered bearing retaining ring (361) in retaining ring groove on outboard (thrust) end of shaft (122), as shown in Fig. 39.
- Slide bearing housings (134) over bearings.
- To torque screws (371C) to 12 ft-lbs (16.3 N.M.) for all 3410 models, proceed as follows:
 - a. Using X pattern, torque screws to 8 ft-lbs (11 N.M.).
 - b. Again, using X pattern, torque screws to 12 ft-lbs (16.3 N.M.).
 - c. Repeat steps 1 and 2 on the other side.
- Using sling, adequate hoist or lift, install rotating element in lower casing.
 - a. Ensure casing wear ring (103) and anti-rotation pins (445A) seat properly in wear ring grooves and pin grooves.
 - b. Using strap wrench, adjust impeller so that it is centered in seated wear rings by tightening or loosening sleeve nuts as required. Torque sleeve nuts (124) (M, L, XL only) to 30 ft-lbs (40.7 N.M.), tighten sleeve nut set screws (222B).



The impeller and wear ring clearance setting procedures must be followed. Improperly setting the clearance or not following any of the proper procedures can result in sparks, unexpected heat generation and equipment damage.

- c. Ensure stuffing box bushings (125) are aligned properly in stuffing boxes.
- To torque bearing housing to lower casing on each side for all 3410 models, proceed as follows:
 - a. Install and tighten screws (372U) until snug.
 - b. Torque screws on each side to 40 ft-lbs (55 N.M.).
 - c. Torque each side to 59 ft-lbs (80 N.M.).
- Ensure mating surfaces on upper and lower casing halves are clean. Install gasket (351).
- Using hoist, lift and sling attached to lifting lugs on upper casing, carefully align and install upper casing. Install dowel pins (496G).
- Install screws (426) and parting nuts (425) on studs (356A). Tighten until snug. To torque nuts and screws, respectively, proceed as follows:
 - 1. Using X pattern working out towards flanges, torque to:
 - S and M – 40 ft-lbs (55 N.M.)
 - L and XL – 60 ft-lbs (80 N.M.)
 - 2. Using the same pattern, increase torque to:
 - S and M – 90 ft-lbs (122 N.M.)
 - L and XL – 180 ft-lbs (245 N.M.)
 - 3. Again, using the same pattern, torque to:
 - S and M – 105 ft-lbs (142 N.M.)
 - L and XL – 255 ft-lbs (345 N.M.)
 - 4. Recheck torque on each nut and screw.
- Install stuffing box packing (106), and lantern rings (105) as outlined in para 2-13.
- Install stuffing box gland (107) and nuts (355). Tighten nut only finger tight. Adjust glands.
- Install oiler (251) and drain plugs, if removed.
- Perform the following as required:
 - 1. Lubricate bearings.
 - 2. Align pump and driver.
 - 3. Connect coupling.
 - 4. Replace coupling guard.
 - 5. Replace sealing liquid.
 - 6. Replace cooling water piping.
 - 7. Prime pump.
 - 8. Inspection after starting.
 - 9. Check stuffing boxes.

3410 EXPLODED VIEW

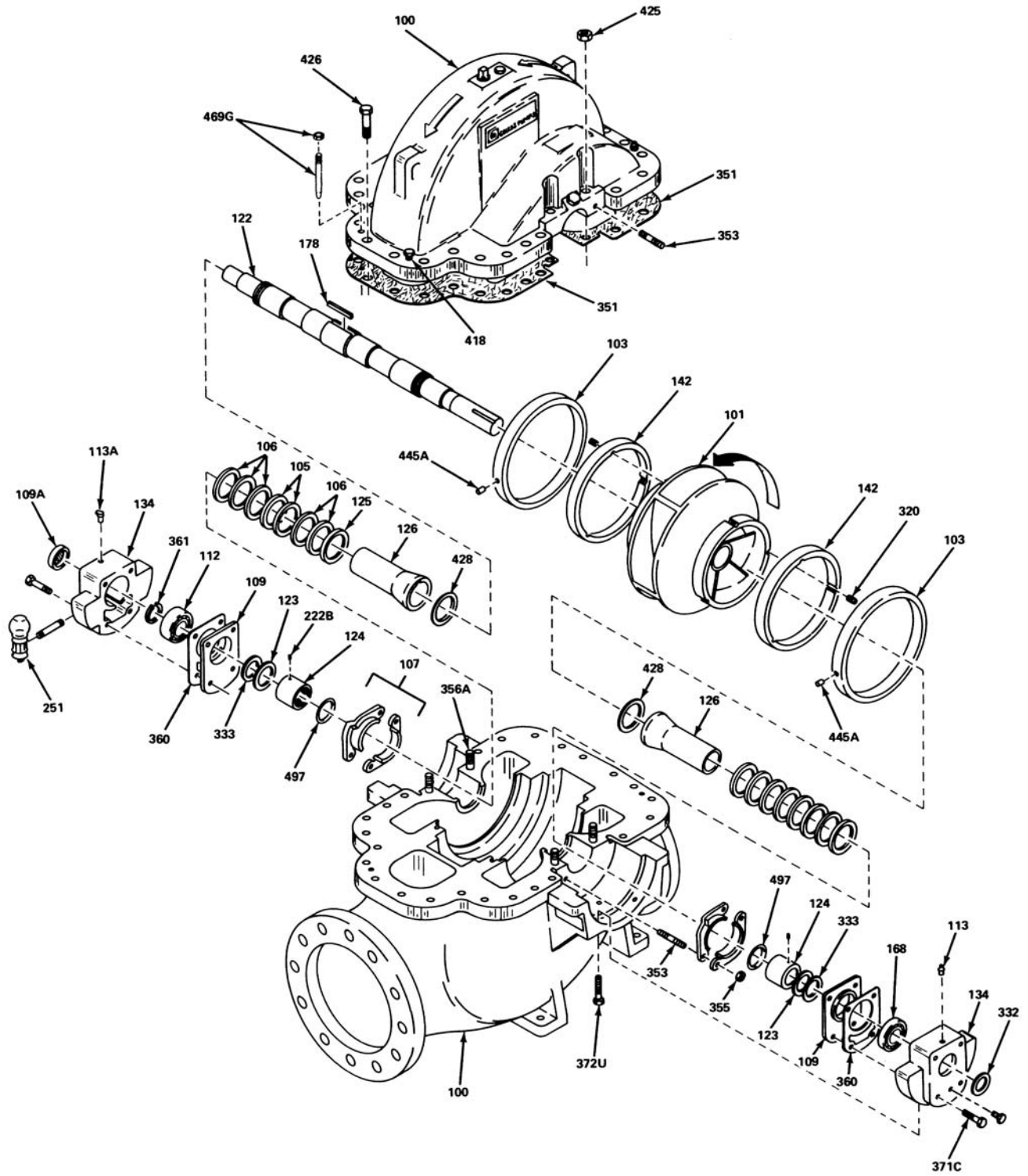

6

Fig. 38

3410 RETAINING RING CONFIGURATION

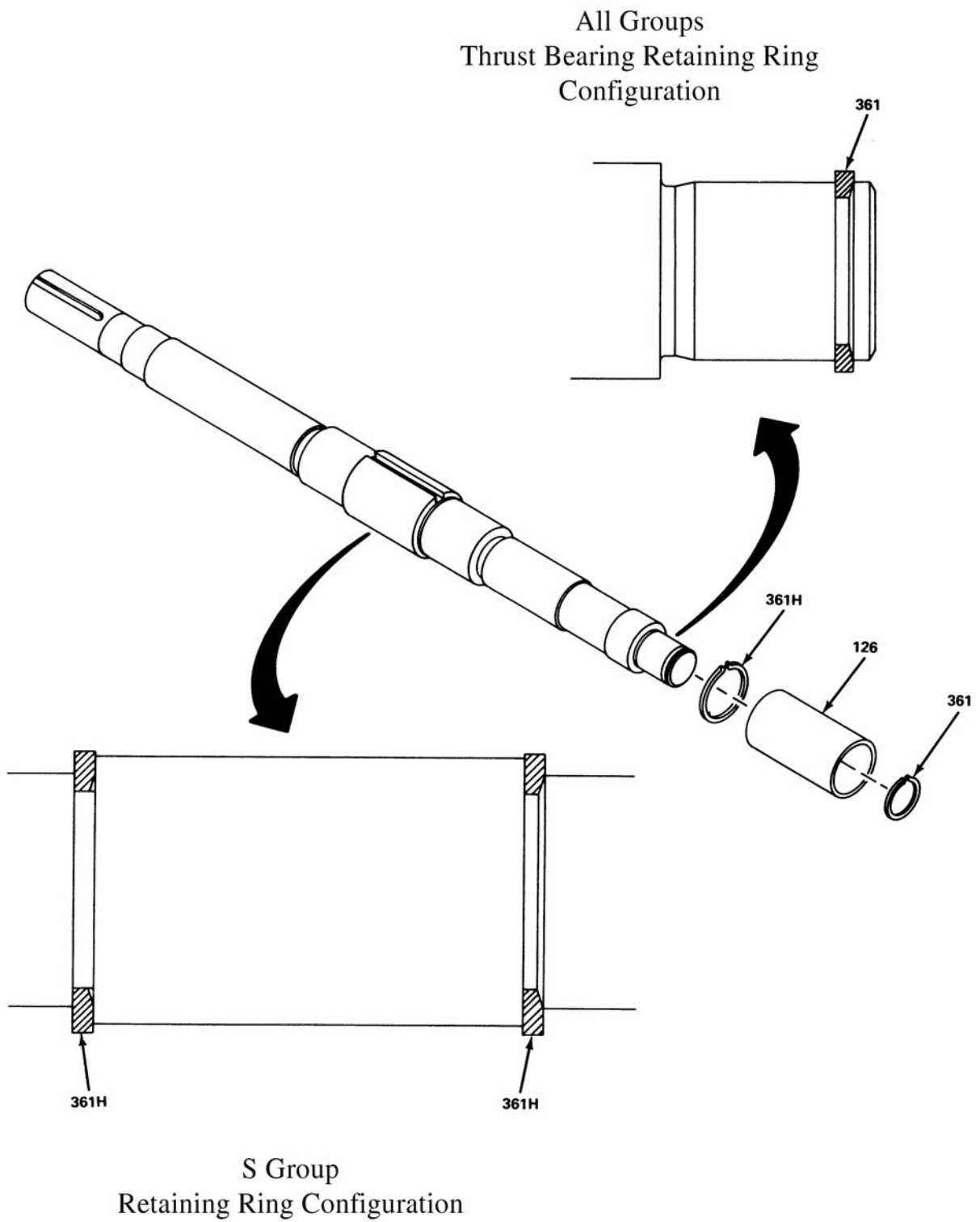

Fig. 39

SPARE PARTS

SPARE PARTS 51
ORDERING SPARE PARTS 51
PARTS LIST AND MATERIALS OF CONSTRUCTION 54

SPARE PARTS

To insure against possible long and costly downtime period, especially on critical services, it is advisable to have spare parts on hand.

The most desirable parts to have on hand are the following:

- Rotating element. This is a group of assembled parts including bearings, bearing housings with seals, shaft, impeller, wear rings, stuffing box bushings, and all rotating parts except the coupling.
- Stuffing box packing and lantern ring (if any) – one set for each stuffing box.
- Mechanical seals (if any) – one seal for each stuffing box.

With these parts on hand, pumps can be easily and quickly reconditioned by replacing the worn parts.

An alternate, though not as desirable as that stated above, is to have on hand parts that are most likely to wear and which can be used as needed.

Following is a list of these suggested parts:

- Stuffing box packing (if any) – one set for each stuffing box.
- Mechanical seal (if any).
- Shaft sleeve (if any).
- Ball bearings – one of each.
- Wear rings (casing and impeller).
- Shaft – one required.
- Impeller key.
- Stuffing box bushings (if any).

If it is not convenient or desirable to carry the spare parts listed above, the following list is suggested as a minimum for servicing the pump under ordinary conditions of wear:

- Stuffing box packing (if any) – one set for each stuffing box.
- Shaft sleeve (if any).
- Ball bearings – one of each.

7

ORDERING SPARE PARTS

Repair orders will be handled with the minimum of delay if the following directions are followed:

- Give Model No., size of the pump, and serial number. These can all be obtained from the nameplate located on lower half casing.

- Write plainly the names, part numbers, and materials of the parts required. These names and numbers should agree with those in the Illustrated Parts List (Table 6). Item numbers are illustrated in Figure 40.
- Give the number of parts required.
- Give complete shipping instructions.

PARTS LIST AND MATERIALS OF CONSTRUCTION

| Item | Qty per Pump | Part Name | Bronze Fitted | All Iron | Iron / 316 Rot. EL. | All 316SS |
|------|--------------------|---|--|----------|---------------------|------------|
| 100 | 1 Upper 1 Lower | Casing | 1003 | 1003 | | A743 CF-8M |
| 101 | 1 | Impeller | 1179 | 1000 | 316 | 316 |
| 102 | 2 | Seal Tubing (optional) | Brass | Steel | | 316 |
| 103 | 2 | Wear Ring, Casing | 1618 | 1000 | 1071 | |
| 105 | 2 | Lantern Ring | Glass Filled Teflon | | | |
| 106 | 1 set | Stuffing Box Packing | Square Non-Asbestos (Die-Formed S&M Groups) | | | |
| 107 | 2 | Stuffing Box Gland | AISI 316 | | | |
| 109 | 2 | Bearing End Cover | 1000 | | | |
| 109A | 1 | Bearing End Cover - Thrust | Steel | | | |
| 112 | 1 | Ball Bearing - Thrust | Steel | | | |
| 113 | 2 | Grease Fitting | Steel | | | |
| 113A | 2 | Breather (Oil Lubrication Only) | Steel | | | |
| 122 | 1 | Shaft | AISI 4140* | | | |
| 123 | 1 | Deflector - (optional) | Laminated Plastic | | | |
| 124 | 1 | Sleeve Nut (M, L, and XL only) | 1618 | 1000 | 1071 | |
| 125 | 2 | Stuffing Box Bushing | 316 | | | |
| 126 | 2 | Shaft Sleeve (optional on S group) | 1618 | 1000 | 316 | |
| 134 | 2 | Bearing Housing | 1000 | | | |
| 142 | 2 | Impeller Wear Ring | 1618 | 1000 | 316 | |
| 168 | 1 | Ball Bearing - Coupling | Steel | | | |
| 178 | 1 | Impeller Key | AISI 1018* | | | |
| 222B | 4 | Set Screw - Sleeve Nuts | Steel | | | |
| 250 | 2 | Gland, Mech Seal (Flush STD)*** | 1179 | 1003 | 1002 | 316 |
| | 2 | Gland, Mech Seal FL-VT-DR (Optional) | Steel | | | |
| 251 | 2 | Sight Oiler (Optional Oil Lubrication) | White Metal and Glass | | | |
| 317 | 2 | Magnetic Seal, Thrust (Optional)*** | Steel | | | |
| 317A | 1 | Magnetic Seal, Radial (Optional)*** | Steel | | | |
| 320 | 6 | Retaining Set Screw - Impeller Wearing Ring (Optional) | 303 SS | | | |
| 332 | 1 | Grease - Oil Seal Outboard | Buna Rubber | | | |
| 332A | 1 | Labyrinth Seal Outboard (Optional)*** | Steel | | | |
| 333 | 2 | Oil Seal - I.B., Grease | Buna Rubber | | | |
| 333A | 1 | Labyrinth Seal Inboard (Optional)*** | Steel | | | |
| 351 | 1 | Casing Gasket, Parting | 1/32" Non-Asbestos | | | |
| 353 | 4 | Studs, Gland | 316 | | | |
| 353B | 2 | H.C. Screw (W/C.I. Mech. Seal Gld.) | Steel | | | |
| | 4 | H.C. Screw (W/Stl. Mech. Seal Gld.) | Steel | | | |
| 355 | 4 | Hex Nut - Gland Stud | 304 | | | |
| 356A | 4 | Stud - Casing Parting | Steel | | | |
| 360 | 2 | Gasket - End Cover to Bearing Housing | Kraft Paper | | | |
| 360Q | 8 | Gasket - Gland to Case | Non-Asbestos | | | |
| 361 | 1 | Retaining Ring, Thrust Bearing | Steel | | | |
| 361H | 2 | Retaining Ring, Impeller (S Group only) | Steel | | Stainless Steel | |
| 371C | 8 | Hex Cap Screw | Steel | | | |
| 372U | 4 | Hex Cap Screw | Steel | | | |
| 418 | 2 | Hex Cap Screw - Casing Jacking | Steel | | | |
| 425 | 4 | Hex Nuts, Parting | Steel | | | |

PARTS LIST AND MATERIALS OF CONSTRUCTION

| Item | Qty per Pump | Part Name | Bronze Fitted | All Iron | Iron / 316 Rot. El. | All 316SS |
|------|--------------|--|----------------------|----------|---------------------|-----------|
| 426 | var. | Hex Cap Screw, Parting | Steel | | | |
| 428 | 2 | Gasket, Sleeve to Impeller (M, L, and XL only) | 1/32" Non-Asbestos | | | |
| 445A | 2 | Anti-Rotation Pin, Casing Wear Ring | AISI 420 | AISI 316 | | |
| 469G | 2 | Tapered Pin W/Hex Nut | Steel | | | |
| 494 | 2 | Cooling Assembly (Optional) | Copper Tube, Fitting | | | |
| 497 | 2 | O-Ring - Sleeve Nut (M, L, and XL only) | Buna Rubber | | | |

MATERIALS OF CONSTRUCTION

| Code | Specification |
|-----------|---|
| 1000 | Cast Iron - ASTM A48 Class 25B |
| 1003 | Cast Iron - ASTM A48 Class 30B |
| 1179 | Bronze - ASTM B584-UNS C87600 |
| 304 | Wrought Stainless - ASTM A276, Type 304 |
| AISI 1018 | ASTM A108, Grade 1018 -B1112 |
| AISI 420 | ASTM A276, Type 420 |
| AISI 4140 | ASTM A322, Grade 4140 |
| 1618 | Bronze -ASTM B584 Alloy C80500 |
| 1071 | Nitronic 60 - ASTM A743 Grade CF10SMnN |

Visit our website at www.gouldspumps.com

Goulds Pumps



ITT Industries