

GOULDS PUMPS

Installation, Operation, and Maintenance Instructions

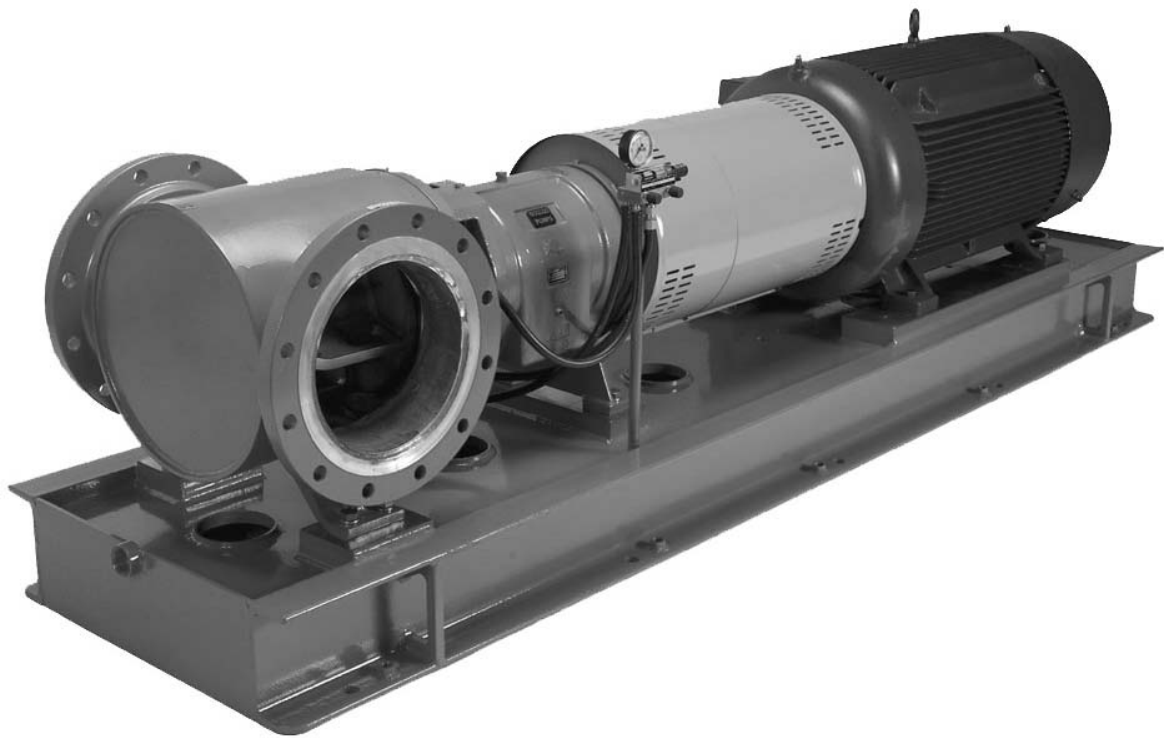

Model 3501 Mixer



ITT

FOREWORD

This manual provides instructions for the Installation, Operation, and Maintenance of the Goulds Model 3501 Optimix™ Medium Consistency Mixer. This manual covers the standard product plus common options that are available. For special options, supplemental instructions are supplied. This manual must be read and understood before installation and start-up.

The design, materials, and workmanship incorporated in the construction of Goulds mixers makes them capable of giving trouble-free service. The life and satisfactory service of any mechanical unit, however, is enhanced and extended by correct application, proper installation, periodic inspection, condition monitoring and careful maintenance. This instruction manual was prepared to assist operators in understanding the construction and the correct methods of installing, operating, and maintaining these mixers.

ITT - Goulds Pumps shall not be liable for physical injury, damage or delays caused by a failure to observe the instructions for Installation, Operation, and Maintenance contained in this manual.

Warranty is valid only when genuine ITT - Goulds parts are used.

Use of the equipment on a service other than stated in the order will nullify the warranty, unless written approval is obtained in advance from ITT - Goulds Pumps.

To assure proper installation, supervision from an authorized manufacturer's representative is recommended.

Additional manuals can be obtained by contacting your local Goulds representative.

THIS MANUAL EXPLAINS

- **Proper Installation**
- **Start-Up Procedures**
- **Operation Procedures**
- **Routine Maintenance**
- **Mixer Overhaul**
- **Troubleshooting**
- **Ordering Spare or Repair Parts**

TABLE OF CONTENTS

PAGE	SECTION	
7	SAFETY	1
9	GENERAL INFORMATION	2
13	INSTALLATION	3
21	OPERATION	4
25	PREVENTIVE MAINTENANCE	5
31	DISASSEMBLY & REASSEMBLY	6
41	SPARE PARTS	7

This page left blank intentionally.

Industrial Process Pump Safety Manual

IMPORTANT SAFETY NOTICE

To: Our Valued Customers

User safety is a major focus in the design of our products. Following the precautions outlined in this manual will minimize your risk of injury.

ITT Goulds pumps will provide safe, trouble-free service when properly installed, maintained, and operated.

Safe installation, operation, and maintenance of ITT Goulds Pumps equipment are an essential end user responsibility. This *Pump Safety Manual* identifies specific safety risks that must be considered at all times during product life. Understanding and adhering to these safety warnings is mandatory to ensure personnel, property, and/or the environment will not be harmed. Adherence to these warnings alone, however, is not sufficient — it is anticipated that the end user will also comply with industry and corporate safety standards. Identifying and eliminating unsafe installation, operating and maintenance practices is the responsibility of all individuals involved in the installation, operation, and maintenance of industrial equipment.

Please take the time to review and understand the safe installation, operation, and maintenance guidelines outlined in this Pump Safety Manual and the Instruction, Operation, and Maintenance (IOM) manual. Current manuals are available at www.gouldspumps.com/literature_ioms.html or by contacting your nearest Goulds Pumps sales representative.

These manuals must be read and understood before installation and start-up.

For additional information, contact your nearest Goulds Pumps sales representative or visit our Web site at www.gouldspumps.com.

SAFETY WARNINGS

Specific to pumping equipment, significant risks bear reinforcement above and beyond normal safety precautions.

 **WARNING**

A pump is a pressure vessel with rotating parts that can be hazardous. Any pressure vessel can explode, rupture, or discharge its contents if sufficiently over pressurized causing death, personal injury, property damage, and/or damage to the environment. All necessary measures must be taken to ensure over pressurization does not occur.

 **WARNING**

Operation of any pumping system with a blocked suction and discharge must be avoided in all cases. Operation, even for a brief period under these conditions, can cause superheating of enclosed pumpage and result in a violent explosion. All necessary measures must be taken by the end user to ensure this condition is avoided.

 **WARNING**

The pump may handle hazardous and/or toxic fluids. Care must be taken to identify the contents of the pump and eliminate the possibility of exposure, particularly if hazardous and/or toxic. Potential hazards include, but are not limited to, high temperature, flammable, acidic, caustic, explosive, and other risks.

 **WARNING**

Pumping equipment Instruction, Operation, and Maintenance manuals clearly identify accepted methods for disassembling pumping units. These methods must be adhered to. Specifically, applying heat to impellers and/or impeller retaining devices to aid in their removal is strictly forbidden. Trapped liquid can rapidly expand and result in a violent explosion and injury.

ITT Goulds Pumps will not accept responsibility for physical injury, damage, or delays caused by a failure to observe the instructions for installation, operation, and maintenance contained in this Pump Safety Manual or the current IOM available at www.gouldspumps.com/literature.

SAFETY

DEFINITIONS

Throughout this manual the words **WARNING**, **CAUTION**, **ELECTRICAL**, and **ATEX** are used to indicate where special operator attention is required.

Observe all Cautions and Warnings highlighted in this Pump Safety Manual and the IOM provided with your equipment.



WARNING

Indicates a hazardous situation which, if not avoided, could result in death or serious injury.

Example: Pump shall never be operated without coupling guard installed correctly.



CAUTION

Indicates a hazardous situation which, if not avoided, could result in minor or moderate injury.

Example: Throttling flow from the suction side may cause cavitation and pump damage.



ELECTRICAL HAZARD

Indicates the possibility of electrical risks if directions are not followed.

Example: Lock out driver power to prevent electric shock, accidental start-up, and physical injury.



















When installed in potentially explosive atmospheres, the instructions that follow the Ex symbol must be followed. Personal injury and/or equipment damage may occur if these instructions are not followed. If there is any question regarding these requirements or if the equipment is to be modified, please contact an ITT Goulds Pumps representative before proceeding.



























Example:  Improper impeller adjustment could cause contact between the rotating and stationary parts, resulting in a spark and heat generation.



















GENERAL PRECAUTIONS

WARNING

A pump is a pressure vessel with rotating parts that can be hazardous. Hazardous fluids may be contained by the pump including high temperature, flammable, acidic, caustic, explosive, and other risks. Operators and maintenance personnel must realize this and follow safety measures. Personal injuries will result if procedures outlined in this manual are not followed. ITT Goulds Pumps will not accept responsibility for physical injury, damage or delays caused by a failure to observe the instructions in this manual and the IOM provided with your equipment.

General Precautions		
WARNING		NEVER APPLY HEAT TO REMOVE IMPELLER. The use of heat may cause an explosion due to trapped fluid, resulting in severe physical injury and property damage.
WARNING		NEVER use heat to disassemble pump due to risk of explosion from trapped liquid.
WARNING		NEVER operate pump without coupling guard correctly installed.
WARNING	 	NEVER run pump below recommended minimum flow when dry, or without prime.
WARNING	 	ALWAYS lock out power to the driver before performing pump maintenance.
WARNING		NEVER operate pump without safety devices installed.
WARNING	 	NEVER operate pump with discharge valve closed.
WARNING	 	NEVER operate pump with suction valve closed.
WARNING	 	DO NOT change service application without approval of an authorized ITT Goulds Pumps representative.
WARNING		<p>Safety Apparel:</p> <ul style="list-style-type: none"> ♦ Insulated work gloves when handling hot bearings or using bearing heater ♦ Heavy work gloves when handling parts with sharp edges, especially impellers ♦ Safety glasses (with side shields) for eye protection ♦ Steel-toed shoes for foot protection when handling parts, heavy tools, etc. ♦ Other personal protective equipment to protect against hazardous/toxic fluids
WARNING		<p>Receiving:</p> <p>Assembled pumping units and their components are heavy. Failure to properly lift and support equipment can result in serious physical injury and/or equipment damage. Lift equipment only at specifically identified lifting points or as instructed in the current IOM. Current manuals are available at www.gouldspumps.com/literature_ioms.html or from your local ITT Goulds Pumps sales representative. Note: Lifting devices (eyebolts, slings, spreaders, etc.) must be rated, selected, and used for the entire load being lifted.</p>

General Precautions		
WARNING	 	Alignment: Shaft alignment procedures must be followed to prevent catastrophic failure of drive components or unintended contact of rotating parts. Follow coupling manufacturer's coupling installation and operation procedures.
WARNING	 	Before beginning any alignment procedure, make sure driver power is locked out. Failure to lock out driver power will result in serious physical injury.
CAUTION	 	Piping: Never draw piping into place by forcing at the flanged connections of the pump. This may impose dangerous strains on the unit and cause misalignment between pump and driver. Pipe strain will adversely effect the operation of the pump resulting in physical injury and damage to the equipment.
WARNING		Flanged Connections: Use only fasteners of the proper size and material.
WARNING		Replace all corroded fasteners.
WARNING		Ensure all fasteners are properly tightened and there are no missing fasteners.
WARNING	 	Startup and Operation: When installing in a potentially explosive environment, please ensure that the motor is properly certified.
WARNING	 	Operating pump in reverse rotation may result in contact of metal parts, heat generation, and breach of containment.
WARNING	 	Lock out driver power to prevent accidental start-up and physical injury.
WARNING	 	The impeller clearance setting procedure must be followed. Improperly setting the clearance or not following any of the proper procedures can result in sparks, unexpected heat generation and equipment damage.
WARNING	 	If using a cartridge mechanical seal, the centering clips must be installed and set screws loosened prior to setting impeller clearance. Failure to do so could result in sparks, heat generation, and mechanical seal damage.
WARNING	 	The coupling used in an ATEX classified environment must be properly certified and must be constructed from a non-sparking material.
WARNING		Never operate a pump without coupling guard properly installed. Personal injury will occur if pump is run without coupling guard.
WARNING	 	Make sure to properly lubricate the bearings. Failure to do so may result in excess heat generation, sparks, and / or premature failure.
CAUTION	 	The mechanical seal used in an ATEX classified environment must be properly certified. Prior to start up, ensure all points of potential leakage of process fluid to the work environment are closed.

General Precautions		
CAUTION	 	Never operate the pump without liquid supplied to mechanical seal. Running a mechanical seal dry, even for a few seconds, can cause seal damage and must be avoided. Physical injury can occur if mechanical seal fails.
WARNING		Never attempt to replace packing until the driver is properly locked out and the coupling spacer is removed.
WARNING	 	Dynamic seals are not allowed in an ATEX classified environment.
WARNING	 	DO NOT operate pump below minimum rated flows or with suction and/or discharge valve closed. These conditions may create an explosive hazard due to vaporization of pumpage and can quickly lead to pump failure and physical injury.
WARNING		Ensure pump is isolated from system and pressure is relieved before disassembling pump, removing plugs, opening vent or drain valves, or disconnecting piping.
WARNING		Shutdown, Disassembly, and Reassembly: Pump components can be heavy. Proper methods of lifting must be employed to avoid physical injury and/or equipment damage. Steel toed shoes must be worn at all times.
WARNING		The pump may handle hazardous and/or toxic fluids. Observe proper decontamination procedures. Proper personal protective equipment should be worn. Precautions must be taken to prevent physical injury. Pumpage must be handled and disposed of in conformance with applicable environmental regulations.
WARNING		Operator must be aware of pumpage and safety precautions to prevent physical injury.
WARNING	 	Lock out driver power to prevent accidental startup and physical injury.
CAUTION		Allow all system and pump components to cool before handling them to prevent physical injury.
CAUTION	 	If pump is a Model NM3171, NM3196, 3198, 3298, V3298, SP3298, 4150, 4550, or 3107, there may be a risk of static electric discharge from plastic parts that are not properly grounded. If pumped fluid is non-conductive, pump should be drained and flushed with a conductive fluid under conditions that will not allow for a spark to be released to the atmosphere.
CAUTION		Wear heavy work gloves when handling impellers as sharp edges may cause physical injury.
CAUTION		Wear insulated gloves when using a bearing heater. Bearings will get hot and can cause physical injury.

ATEX CONSIDERATIONS and INTENDED USE

Special care must be taken in potentially explosive environments to ensure that the equipment is properly maintained. This includes but is not limited to:

1. Monitoring the pump frame and liquid end temperature.
2. Maintaining proper bearing lubrication.
3. Ensuring that the pump is operated in the intended hydraulic range.

The ATEX conformance is only applicable when the pump unit is operated within its intended use. Operating, installing or maintaining the pump unit in any way that is not covered in the Instruction, Operation, and Maintenance manual (IOM) can cause serious personal injury or damage to the equipment. This includes any modification to the equipment or use of parts not provided by ITT Goulds Pumps. If there is any question regarding the intended use of the equipment, please contact an ITT Goulds representative before proceeding. Current IOMs are available at www.gouldspumps.com/literature_ioms.html or from your local ITT Goulds Pumps Sales representative.

All pumping unit (pump, seal, coupling, motor and pump accessories) certified for use in an ATEX classified environment, are identified by an ATEX tag secured to the pump or the baseplate on which it is mounted. A typical tag would look like this:



The CE and the Ex designate the ATEX compliance. The code directly below these symbols reads as follows:

- II = Group 2
- 2 = Category 2
- G/D = Gas and Dust present
- T4 = Temperature class, can be T1 to T6 (see Table 1)

Code	Max permissible surface temperature °F (°C)	Max permissible liquid temperature °F (°C)
T1	842 (450)	700 (372)
T2	572 (300)	530 (277)
T3	392 (200)	350 (177)
T4	275 (135)	235 (113)
T5	212 (100)	Option not available
T6	185 (85)	Option not available

The code classification marked on the equipment must be in accordance with the specified area where the equipment will be installed. If it is not, do not operate the equipment and contact your ITT Goulds Pumps sales representative before proceeding.

PARTS



The use of genuine Goulds parts will provide the safest and most reliable operation of your pump. ITT Goulds Pumps ISO certification and quality control procedures ensure the parts are manufactured to the highest quality and safety levels.

Please contact your local Goulds representative for details on genuine Goulds parts.

GENERAL INFORMATION

MIXER DESCRIPTION	9
NAMEPLATE INFORMATION	10
RECEIVING THE MIXER	11

MIXER DESCRIPTION

2

Casing - Casings are side suction, side discharge, back pull-out designs, utilizing a spacer coupling to allow for one craft maintenance. The alignment fit is protected from the pumpage with a confined gasket between the casing and the seal chamber cover.

Rotor - The fully open multi-vane rotor is supplied on all mixers. It is engineered to effectively open and loosen the fiber network to provide complete and efficient chemical or gas mixing. The rotors have been designed to handle the tough medium consistency paper stock services. The rotor is keyed to the shaft and held in position by a rotor locknut, sealed by a Teflon® O-ring and secured with setscrews. The sleeve side of the rotor is sealed by a Teflon® O-ring for a dry shaft design.

Shaft Sleeves - The sleeve is a renewable hook type, positively driven by the rotor key. One end is free to expand due to possible temperature variations. A Teflon® O-ring prevents leakage under the sleeve.

Power End - The heavy duty bearing frame and housing are both constructed of cast iron. The frame is bolted and rabbeted to the seal chamber. The inboard bearing (cylindrical roller) carries radial loads only and is free to float axially within the bearing frame. The outboard bearing is 40° angular contact duplex set mounted back-to-back, locked on the shaft by a threaded locknut and carries both radial and axial loads. The frame is sealed with labyrinth seals as standard. Flood oil lubrication is standard. Grease lubrication is available as an option. No special parts are required to convert from grease to oil lubrication. Bearing frame cooling can be supplied as an option with oil lubrication.

Seal Chamber - The seal chamber is especially designed for medium consistency mixing applications. Its wide open design keeps the stock flowing without dewatering and binding the seal.

Hardware - All fasteners and tapped connections are metric.

Direction of Rotation - Clockwise (right hand) as viewed from the driver looking at the mixer shaft.

NAMEPLATE INFORMATION

Every mixer has two Goulds nameplates that provide information about the mixer. The tags are located on the casing and bearing frame. When ordering spare parts you will need to identify the mixer model, size, serial number, and the number of required parts.

Mixer Casing Tag - provides information about the mixer's hydraulic characteristics (Fig. 1 or 2).

Bearing Frame Tag - provides recommended type of lubrication the mixer should use (Fig. 3).

GOULDS PUMPS, INC.
 SENECA FALLS, N.Y. MADE IN U.S.A.
 CAUTION: AFTER STARTING DO NOT OPERATE AGAINST CLOSED VALVE.

STD. NO. MAT'L. CONSTR.

IMPLR. DIA. MAX. DIA.

MODEL SIZE

GPH FT. HD. RPM

SER. NO. MAX. DSGN. PSI ± 100° F

Fig. 1
(English)

GOULDS PUMPS, INC.
 SENECA FALLS, N.Y. MADE IN U.S.A.
 CAUTION: AFTER STARTING DO NOT OPERATE AGAINST CLOSED VALVE.

STD. NO. MAT'L. CONSTR.

IMPLR. DIA. MAX. DIA.

MODEL H HD

M³/HR FT. HD. RPM

SER. NO. MAX. DSGN. KG/CM² @ 20°C

Fig. 2
(Metric)

GOULDS PUMPS INC.
 SENECA FALLS, N.Y. MADE IN USA

MOD.

SIZE

SER. NO.

LUBE

Fig. 3

RECEIVING THE MIXER

Inspect the mixer as soon as it is received. Carefully check that everything is in good order. Make notes of damaged or missing items on the receipt and freight bill. File any claims with the transportation company as soon as possible.

Storage Requirements

Short Term: (Less than 6 months): Goulds normal packaging procedure is designed to protect the mixer during shipping. Upon receipt store in a covered and dry location.

Long Term: (More than 6 months): Requires special precautions. Preservative treatment of bearings and machined surfaces will be required. Rotate shaft several times every 3 months. Driver and coupling manufacturers should be contacted for long term storage procedures.

NOTE: For pumps or back pull-outs supplied with cartridge mechanical seals, the centering tabs must be in place and tightened, and the set screw collar loosened. Failure to take these steps could result in damage to the mechanical seal or shaft sleeve.

HANDLING

Use care when moving mixers. Lifting equipment must be able to adequately support the entire assembly. Hoist bare mixer using a suitable sling, under the suction and discharge flange and bearing frame. Baseplate mounted units are moved with slings under the mixer casing flanges and driver. Refer to figures 4, 5 and 6 for examples of proper lifting techniques.

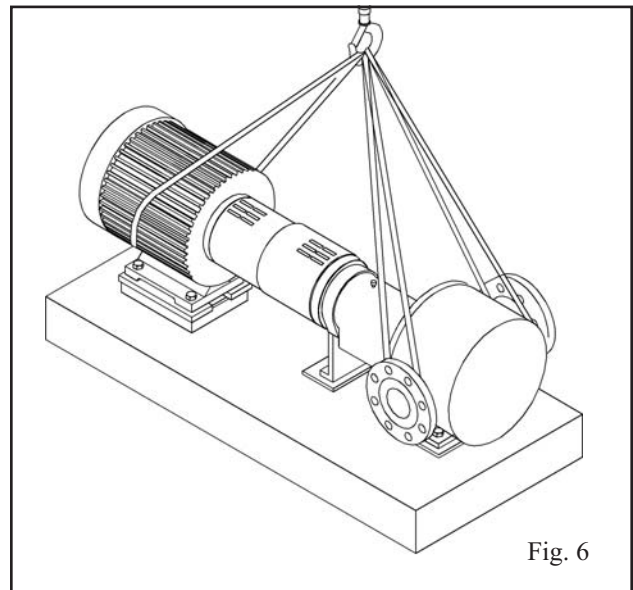
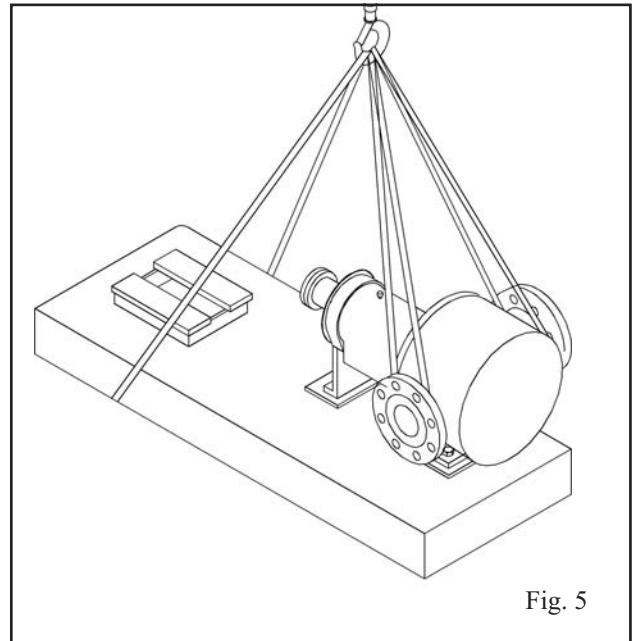
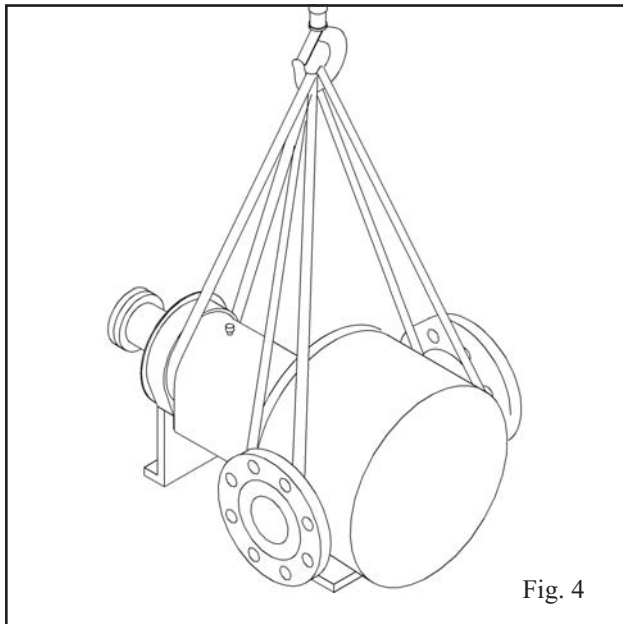

This page left blank intentionally.

INSTALLATION

SITE/FOUNDATION	13
LEVEL BASEPLATE	14
ALIGNMENT AND ALIGNMENT PROCEDURE	14
Alignment Checks	14
Alignment Criteria	15
Set Up.	15
Measurement	15
Angular Alignment	15
Parallel Alignment	16
Complete Alignment	16
ALIGNMENT TROUBLESHOOTING	17
GROUT BASEPLATE	17
Alignment Check	17
PIPING	18
General	18
Inlet Piping	18
Outlet Piping	18
Final Piping Check	18
PIPING INSTRUCTIONS	18
Liquid Mixing	18
Gas Mixing	19
SPRING MOUNTED BASEPLATE	19

NOTE: *If equipment is removed from baseplate during installation, each item should be tagged with an identification number. In order to ensure proper alignment, equipment must be returned to the original baseplate.*

SITE / FOUNDATION

A mixer should have adequate space for operation, maintenance, and inspection.

Baseplate mounted mixers are normally grouted on a concrete foundation, which has been poured on a solid footing. The foundation must be able to absorb any vibration and to form a permanent, rigid support for the mixing unit.

The location and size of the foundation bolts are shown on the outline assembly drawing provided with the mixer data package.

Foundation bolts commonly used are sleeve type (Fig. 7) and J type (Fig. 8). Both designs permit movement for final bolt adjustment.

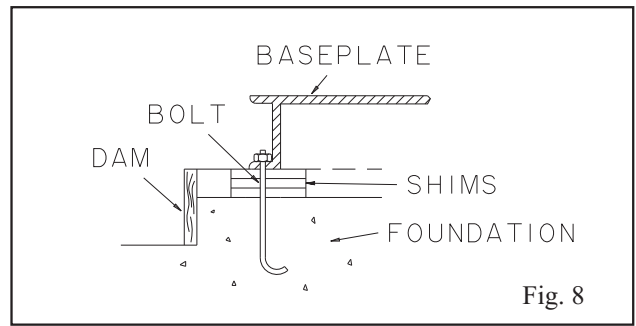
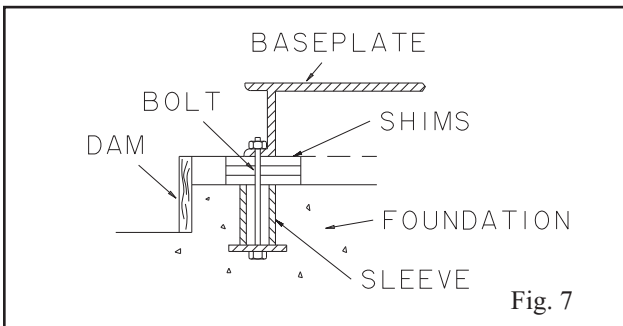

LEVEL BASEPLATE

1. Place two sets of wedges or shims on the foundation, one set on each side of every foundation bolt. The wedges should extend 20 mm (.75 in.) to 40 mm (1.5 in.) above foundation, to allow for adequate grouting. This will provide even support for the baseplate once it is grouted (Fig. 9 and Fig. 10).
2. Remove water and/or debris from anchor bolt holes/sleeves prior to grouting. If the sleeve type bolts are being used, fill the sleeves with rags to prevent grout from entering.
3. Carefully lower baseplate onto foundation bolts.
4. Level baseplate to within 3.2 mm (.125 in.) over length of the baseplate and to within 1.5 mm (.060 in.) over the width of the base by adjusting wedges.
5. Hand tighten bolts.

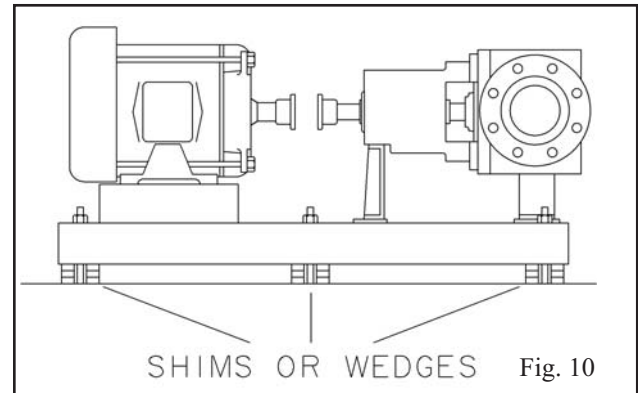
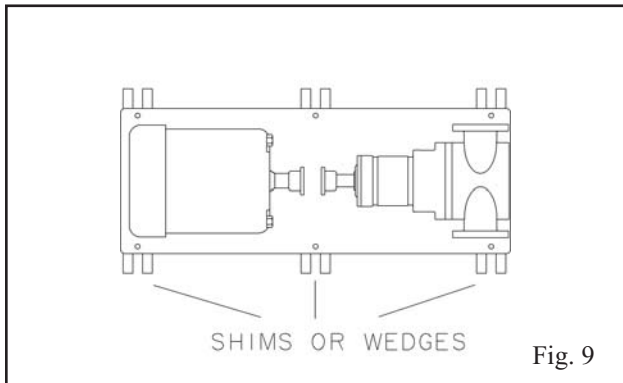

ALIGNMENT AND ALIGNMENT PROCEDURE



WARNING

Before beginning any alignment procedure, make sure driver power is locked out.

The points at which alignment is checked and adjusted are:

- **Initial Alignment** is done prior to operation when the mixer and the driver are at ambient temperature
- **Final Alignment** is done after operation when the mixer and driver are at operating temperature

Alignment is achieved by adding or removing shims from under the feet of the driver and shifting equipment horizontally as needed.

NOTE: Proper alignment is the responsibility of the installer and user of the unit.

Accurate alignment of the equipment must be attained. Trouble-free operation can be accomplished by following these procedures.

ALIGNMENT CHECKS

Initial Alignment (Cold Alignment)

- Before Grouting Baseplate - To ensure alignment can be obtained
- After Grouting Baseplate - To ensure no changes have occurred during grouting process
- After Connecting Piping - To ensure pipe strains haven't altered alignment. If changes have occurred, alter piping to remove pipe strains on mixer flanges

Final Alignment (Hot Alignment)

- After First Run - To obtain correct alignment when both mixer and driver are at operating temperature. Thereafter, alignment should be checked periodically in accordance with plant operating procedures.

ALIGNMENT CRITERIA

Good alignment is achieved when the dial indicator readings as specified in the alignment procedure are .05 mm (.002 in.) Total Indicated Reading (T.I.R.) or less when the mixer and driver are at operating temperature (Final Alignment).

During the installation phase, however, it is necessary to set the parallel alignment in the vertical direction to a different criteria due to differences in expansion rates of the mixer and driver. For Model 3501, *Table 1* shows recommended preliminary (cold) settings for electric motor driven mixers based on different pumpage temperatures. Driver manufacturers should be consulted for recommended cold settings for other types of drivers (steam turbines, engines, etc.).

Fluid Temperature	Set Driver Shaft
10° C (50° F)	.05 mm (.002 in.) Low
65° C (150° F)	.03 mm (.001 in.) High
120° C (250° F)	.12 mm (.005 in.) High

SET UP

1. Mount two dial indicators on one of the coupling halves (X) so they contact the other coupling half (Y) (Fig. 11).
2. Check setting of indicators by rotating coupling half X to ensure indicators stay in contact with coupling half Y but do not bottom out. Adjust indicators accordingly.

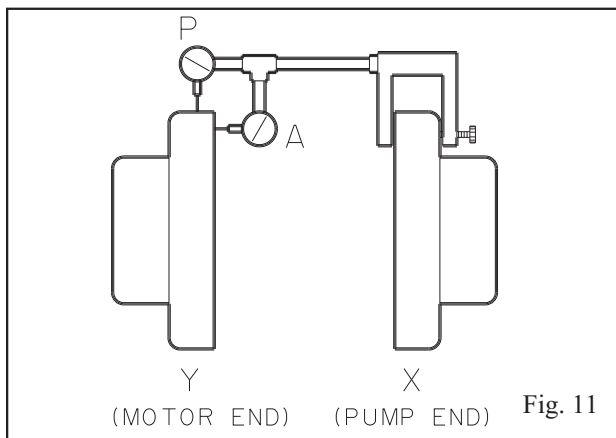

MEASUREMENT

1. To ensure accuracy of indicator readings, always rotate both coupling halves together so indicators contact the same point on coupling half Y. This will eliminate any measurement problems due to runout on coupling half Y.

2. Take indicator measurements with driver feet hold-down bolts tightened. Loosen hold down bolts prior to making alignment corrections.

NOTE: Take care not to damage indicators when moving driver during alignment corrections.

ANGULAR ALIGNMENT

A unit is in angular alignment when indicator A (Angular indicator) does not vary by more than .05 mm (.002 in.) as measured at four points 90° apart.

Vertical Correction (Top-to-Bottom)

1. Zero indicator A at top dead center (12 o'clock) of coupling half Y.
2. Rotate indicators to bottom dead center (6 o'clock). Observe needle and record reading.
3. **Negative Reading** - The coupling halves are further apart at the bottom than at the top. Correct by either raising the driver feet at the shaft end (add shims) or lowering the driver feet at the other end (remove shims) (Fig. 12).

Positive Reading - The coupling halves are closer at the bottom than at the top. Correct by either lowering the driver feet at the shaft end (remove shims) or raising the driver feet at the other end (add shims).

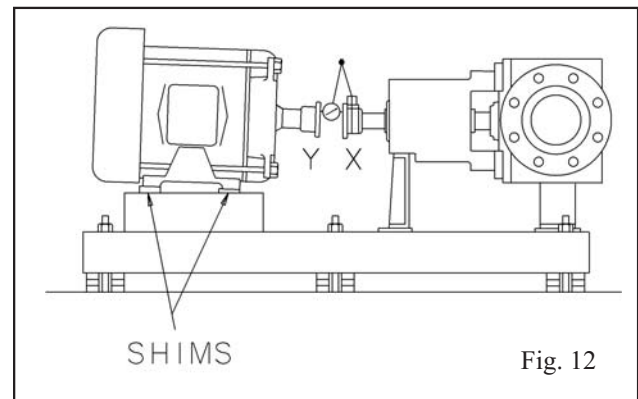

4. Repeat steps 1-3 until indicator A reads .05 mm (.002 in) or less.

Horizontal Correction (Side-to-Side)

1. Zero indicator A on left side of coupling half Y, 90° from top dead center (9 o'clock).
2. Rotate indicators through top dead center to the right side, 180° from the start (3 o'clock). Observe needle and record reading.
3. **Negative Reading** - The coupling halves are further apart on the right side than the left. Correct by either sliding the shaft end of the driver to the left or the other end to the right.

Positive Reading - The coupling halves are closer together on the right side than the left. Correct by either sliding the shaft end of the driver to the right or the other end to the left (Fig. 13).

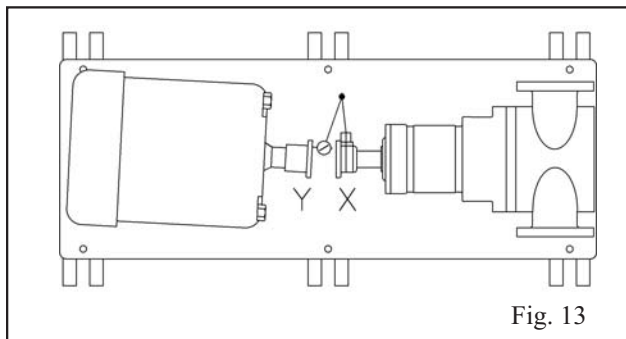

Fig. 13

4. Repeat steps 1 through 3 until indicator A reads .05 mm (.002 in.) or less.
5. Re-check both horizontal and vertical readings to ensure adjustment of one did not disturb the other. Correct as necessary.

PARALLEL ALIGNMENT

A unit is in parallel alignment when indicator P (parallel indicator) does not vary by more than .05 mm (.002 in.) as measured at four points 90° apart at operating temperature. Note the preliminary vertical cold setting criteria, *Table 1*.

Vertical Correction (Top-to-Bottom)

1. Zero indicator P at top dead center of coupling (12 o'clock) half Y (Fig. 11).
2. Rotate indicator to bottom dead center (6 o'clock). Observe needle and record reading.
3. **Negative Reading** - Coupling half X is lower than coupling half Y. Correct by removing shims of thickness equal to half of the indicator reading under each driver foot.

Positive Reading - Coupling half X is higher than coupling half Y. Correct by adding shims of thickness equal to half of the indicator reading from each driver foot (Fig. 14).

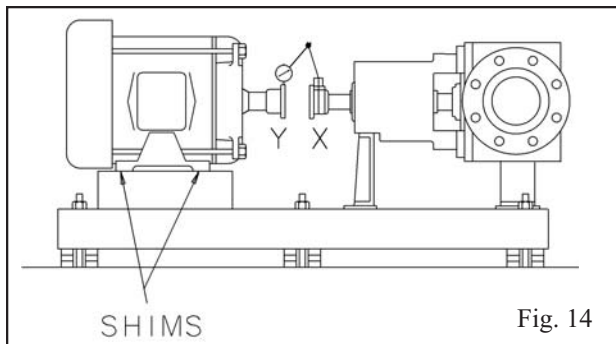

Fig. 14

NOTE: Equal amounts of shims must be added to or removed from each driver foot. Otherwise the vertical angular alignment will be affected.

4. Repeat steps 1 through 3 until indicator P reads within .05 mm (.002 in.) or less when hot, or per *Table 1* when cold.

Horizontal Correction (Side-to-Side)

1. Zero indicator P on the left side of coupling half Y, 90° from top dead center (9 o'clock).
2. Rotate indicators through top dead center to the right side, 180° from the start (3 o'clock). Observe needle and record reading.
3. **Negative Reading** - Coupling half Y is to the left of coupling half X. Correct by sliding driver evenly in the appropriate direction (Fig. 15).

Positive Reading - Coupling half Y is to the right of coupling half X. Correct by sliding driver evenly in the appropriate direction.

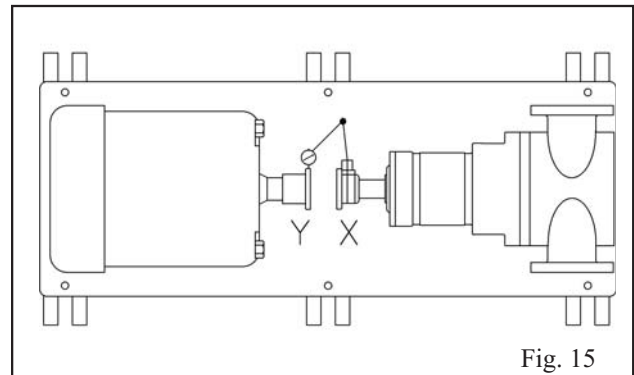

Fig. 15

NOTE: Failure to slide motor evenly will affect horizontal angular correction.

4. Repeat steps 1 through 3 until indicator P reads .05 mm (.002 in.) or less.
5. Re-check both horizontal and vertical readings to ensure adjustment of one did not disturb the other. Correct as necessary.

COMPLETE ALIGNMENT

A unit is in complete alignment when both indicators A (angular) and P (parallel) do not vary by more than .05 mm (.002 in.) as measured at four points 90° apart.

Vertical Correction (Top-to-Bottom)

1. Zero indicators A and P at top dead center (12 o'clock) of coupling half Y.
2. Rotate indicator to bottom dead center (6 o'clock). Observe the needles and record the readings.
3. Make corrections as outlined previously.

Horizontal Correction (Side-to-Side)

1. Zero indicators A and P on the left side of coupling half Y, 90° from top dead center (9 o'clock).
2. Rotate indicators through top dead center to the right side, 180° from the start (3 o'clock). Observe the needle, measure and record the reading.

3. Make corrections as outlined previously.
4. Recheck both vertical and horizontal readings to ensure adjustment of one did not disturb the other. Correct as necessary.

NOTE: With experience, the installer will understand the interaction between angular and parallel and will make corrections appropriately.

Table 2 ALIGNMENT TROUBLESHOOTING		
Problem	Probable Cause	Remedy
Cannot obtain horizontal (Side-to-Side) alignment, angular or parallel	Driver feet bolt bound.	Loosen mixer hold down bolts and slide mixer and driver until horizontal alignment is achieved.
	Baseplate not leveled properly, probably twisted.	Determine which corner(s) of the baseplate are high or low and remove or add shims at the appropriate corner(s) and realign.
Cannot obtain vertical (Top-to-Bottom) alignment, angular or parallel	Baseplate not leveled properly, probably bowed.	Determine if center of baseplate should be raised or lowered and correct by evenly adding or removing shims at the center of the baseplate.

GROUT BASEPLATE

1. Clean areas of baseplate that will contact grout. Do not use oil-based cleaners because grout will not bond to it. Refer to grout manufacturer's instructions.
2. Build dam around foundation. Thoroughly wet foundation (Fig. 16).
3. Pour grout through grout hole in baseplate, up to level of dam. Remove air bubbles from grout as it is poured by puddling, using a vibrator, or pumping the grout into place. Non-shrink grout is recommended.
4. Allow grout to set.
5. Fill remainder of baseplate with grout. Remove air as before (Fig. 17).

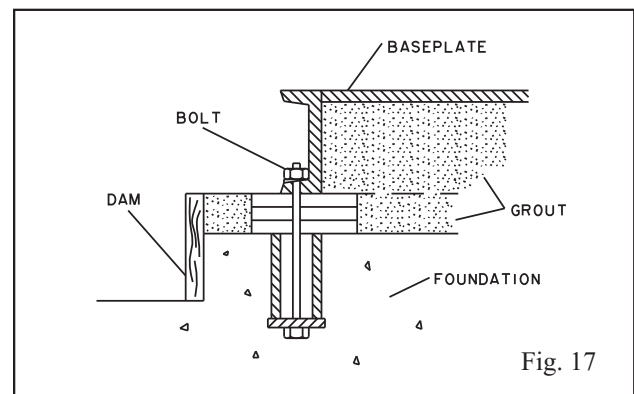
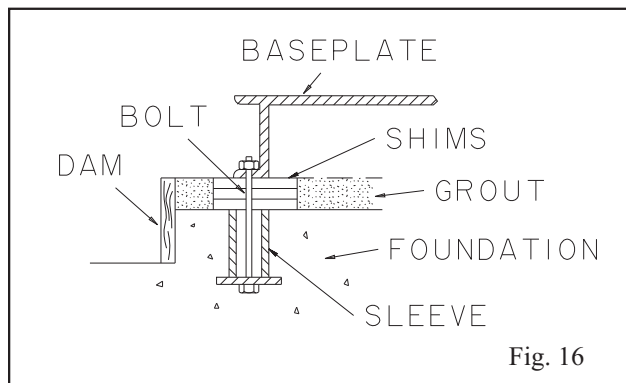

6. Allow grout to set at least 48 hours.
7. Tighten foundation bolts.

ALIGNMENT CHECK

Re-check alignment before continuing, using methods previously described.

PIPING

GENERAL



WARNING

Never draw piping into place by forcing at the flanged connections of the mixer. This may impose dangerous strains on the unit and cause misalignment between mixer and driver. Pipe strain will adversely effect the operation of the mixer resulting in physical injury and damage to the equipment.



WARNING

These mixers are commonly used in high temperature applications (>150°F). Due to thermal expansion in these services, special precautions must be taken to insure that flange loads do not exceed the limits of the mixer. Contact your Goulds representative for information on the maximum flange loads.

1. All piping must be supported independently of, and line up naturally with, the mixer flanges.
2. Piping runs should be as short as possible to minimize friction losses.
3. **DO NOT** connect piping to mixer until grout has hardened and mixer and driver hold-down bolts have been tightened.
4. It is suggested that expansion loops or joints be properly installed in inlet and/or outlet lines when handling liquids at elevated temperatures, so linear expansion of piping will not draw mixer out of alignment.
5. The piping should be arranged to allow mixer flushing prior to removal of the unit on services handling corrosive liquids.
6. Carefully clean all pipe parts, valves and fittings, and mixer branches prior to assembly.

INLET PIPING

Properly installed inlet piping is a necessity for trouble-free mixer operation. Inlet piping should be flushed **BEFORE** connection to the mixer.

1. Use of elbows close to the mixer inlet flange should be avoided. There should be a minimum of two (2) pipe diameters of straight pipe between the elbow and inlet. Where used, elbows should be long radius.
2. Use pipe one or two sizes larger than the mixer inlet, with a reducer before the chemical feed location. Piping should never be of smaller diameter than the mixer inlet.
3. Reducers, if used, should be abrupt stepped designs, not tapered.
4. An isolation valve should be installed in the inlet line at least four (4) pipe diameters from the inlet to permit closing of the line for mixer inspection and maintenance.
5. Keep inlet pipe free from air pockets.
6. Piping should be level or slope gradually downward from the source of supply.

OUTLET PIPING

1. Isolation valves should be installed in outlet line. The isolation valve is required for inspection and maintenance of mixer.

FINAL PIPING CHECK

After connecting the piping to mixer:

1. Rotate shaft several times by hand to be sure that there is no binding and all parts are free.
2. Check alignment, per the alignment procedure outlined previously to determine absence of pipe strain. If pipe strain exists, correct piping.

PIPING INSTRUCTIONS

LIQUID MIXING

Pipe

- Material selection is based upon the chemicals mixed and their temperatures.
- There are no special requirements for increasers, elbows or other fittings after the mixer.

Chemical Injection Pipe

- Is two (2') feet long and the same size and material as the mixer.
- Is part of the mixer design package.

Valves

- Control valve is typically before the mixer.
- If additional back pressure is required, the control valve may be after the mixer.
- Shut off valves should be after the mixer.

GAS MIXING

Pipe

- Gas addition should always be added in the chemical addition point of the chemical injection pipe supplied with the mixer.
- If flow velocity is higher than 9 ft/s, special 8° increasers are required after the mixer.
- Before any elbows, the flow velocity must be lower than 2 ft/s.
- Flow velocity into a tower must be 1.5 ft/s or lower.
- Recommended angle at the bottom of the upflow reactor is 36°.

Chemical Injection Pipe

- Is two (2') feet long and the same size and material as the mixer.
- Is part of the mixer design package.

Valves

- Control valve cannot be after the mixer.
- Shut off valve should be after the mixer.
- The inner diameter of the shut off valve(s) must be full port (same size as the inner diameter of the pipe).

Pipe Supports - Liquid and Gas Mixing

- Special care needs to be taken when designing pipe supports around the mixer.
- Often process temperatures are high, causing thermal expansion and high loading.
- Steam addition and steam mixing can cause thermal expansion and high loading.

Mixer Flange Loads

- Allowable flange loads for the suction and discharge nozzles are available.

SPRING MOUNTED BASEPLATES

1. Raise or support the baseplate above the foundation/floor. Be sure to allow enough room under the baseplate to install the spring assemblies.
2. Set the bottom adjusting nuts on each spring stud to the height indicated on the certified dimensional drawing.
3. Insert a washer between the bottom adjusting nut and the spring follower. Install a spring and another follower. Install this subassembly from the bottom of the baseplate.
4. Install the upper half of the spring assembly consisting of a follower, a spring, another follower, and a flat washer. Now install the top adjusting nut and jam nut. Tighten finger tight.
5. Repeat steps one through four for all the spring assemblies.
6. Once all the springs have been installed, lower the unit on to the foundation pads.

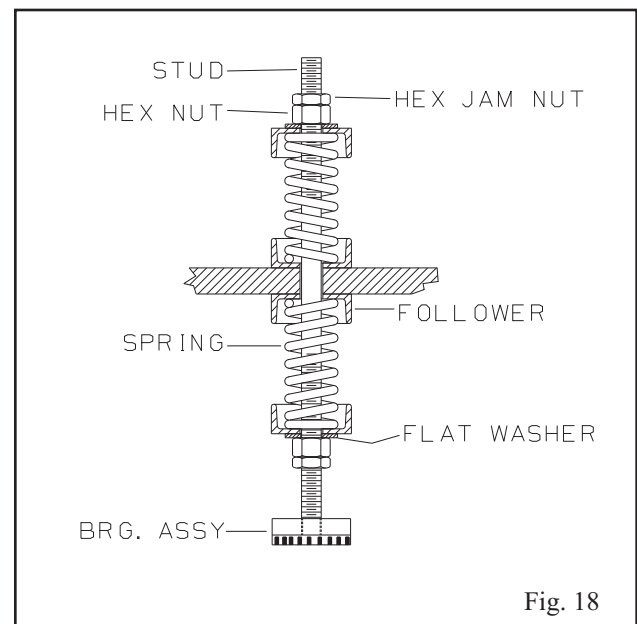

Fig. 18

NOTE: The foundation pads are supplied by the customer. They are to be 16-20 micro-inch surface finish 316 stainless steel plate.

7. Level the baseplate while making final height adjustments. Adjust the baseplate height by loosening the top jam nut and adjusting nut. Change the height by moving the lower adjusting nut. When the baseplate is level, tighten the top adjusting nuts just enough to make sure the top springs are not loose in their followers and then snug the lower and upper jam nuts.

NOTE: Suction and discharge piping must be individually supported. The spring mounted baseplates are designed to support piping loads developed by thermal expansion only.

OPERATION

PREPARATION FOR START-UP	21
Check Rotation	21
Check Rotor Axial Clearance	21
Couple Mixer and Driver	21
Lubricating Bearings	22
Shaft Sealing	22
STARTING MIXER	22
OPERATION	23
General Considerations	23
Operating at Reduced Capacity	23
Operating under Freezing Conditions	23
SHUTDOWN	23
FINAL ALIGNMENT	23
INTERLOCKS	24

PREPARATION FOR START-UP

CHECK ROTATION



CAUTION

Serious damage may result if mixer is run in the wrong rotation.

1. Lock out power to driver.



WARNING

Lock out driver power to prevent accidental start-up and physical injury.

2. Make sure coupling hubs are securely fastened to shafts.

NOTE: Mixer is shipped with coupling spacer removed.

3. Unlock driver power.
4. Make sure everyone is clear. Jog driver just long enough to determine direction of rotation. Rotation must correspond to arrow on bearing housing.
5. Lock out power to driver.

CHECK ROTOR AXIAL CLEARANCE

The mixer efficiency is maintained when the proper rotor clearance is set. The rotor has been centered in the casing at the factory but could change due to piping attachment. See *Preventive Maintenance* section for rotor adjustment procedure.

COUPLE MIXER AND DRIVER



WARNING

Lock out driver power to prevent accidental rotation and physical injury.

1. Install and lubricate coupling per manufacturer's instructions.
2. Install coupling guard (Fig. 19).



WARNING

Never operate a mixer without a correctly installed coupling guard. Personal injury will occur if mixer is run without coupling guard.

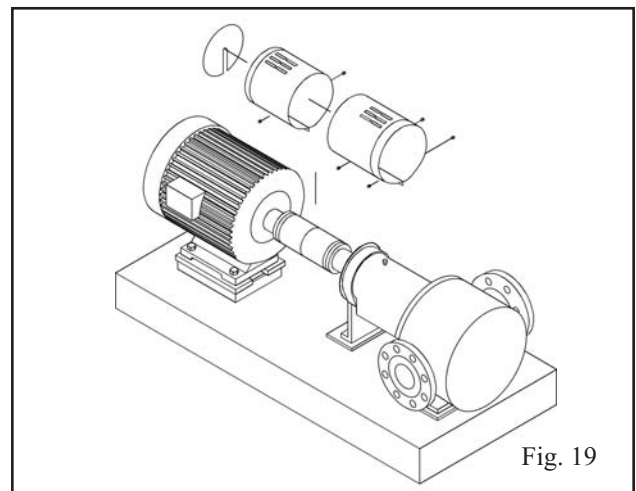

Fig. 19

LUBRICATING BEARINGS

Oil Lubrication: Mixers are shipped **without** oil. Fill the bearing frame with oil, through the filler connection (located on top of bearing frame), until the level reaches the mark in the middle of the oil level sight-glass. A high quality turbine type oil with rust and oxidation inhibitors should be used.

If the constant level oiler option is supplied, it would be in the box of fittings which accompanies the mixer. The oiler was adjusted before leaving the factory, however, the oil level setting must be checked prior to operation (Fig. 20). Fill the oiler bottle with oil and replace in the oiler housing. Oil reservoir in bearing frame is filled when oil remains visible in the bottle. Several fillings of the bottle may be required (Fig. 20).

Grease Lubrication: Mixers are shipped **with** grease installed.

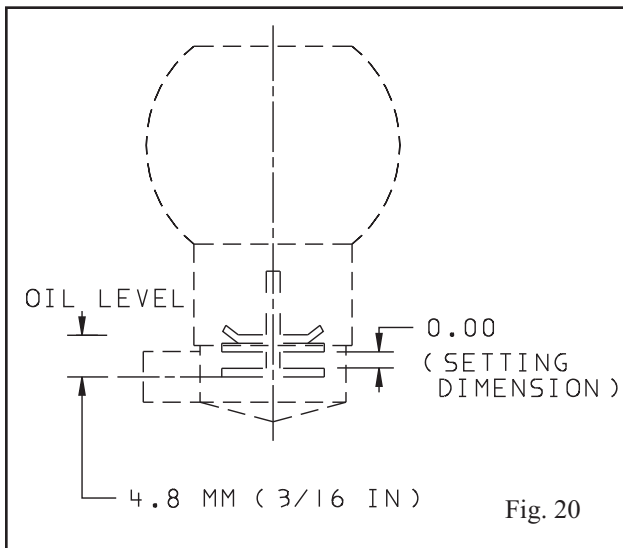

Prolonged Shutdown: If the mixer is put into operation after prolonged shut-down, flush out the bearings and bearing frame with a light oil or kerosene to remove contaminants. During flushing, rotate shaft slowly. Finally, flush the bearing housing with the proper lubricating oil to insure oil quality after cleaning.

Regrease bearings prior to starting as described in "Maintenance of Bearings."



WARNING

Operation of the unit without proper lubrication will cause bearing failure and mixer seizure.

SHAFT SEALING

Mechanical Seal: Mixers are shipped with mechanical seals installed. The most common seal with this model is the cartridge type. Cartridge seals are preset at the factory and require no field settings, unless seal is removed.

Connection of Sealing Liquid: For satisfactory operation, there must be a liquid film between seal faces to lubricate them. Refer to seal manufacturer's drawing for location of taps. The primary method used to flush/cool the seal is an external flush where a clean, cool, compatible liquid is injected from an outside source directly into seal gland between the double seal faces. Flushing liquid must be at a pressure 1.0 kg/cm^2 (15 PSI) above seal chamber pressure. Injection rate should be 4-8 liters per minute (1-2 gallons per minute).

STARTING MIXER

1. Make sure inlet valve and any recirculation or cooling lines are open.
2. Make sure outlet valve is open as dictated by system conditions.
3. Start Driver.

OPERATION

GENERAL CONSIDERATIONS

Driver may overload if the fluid specific gravity (density) is greater than originally assumed or the rated flow rate is exceeded.

Always operate the mixer at or near the rated conditions to prevent damage resulting from cavitation or recirculation.

OPERATING AT REDUCED CAPACITY



WARNING

DO NOT operate mixer below minimum rated flows or with inlet and/or outlet valve closed. These conditions may create an explosive hazard due to vaporization of fluid and can quickly lead to mixer failure and physical injury.

Damage occurs from:

1. **Increased Vibration Levels** - Affects bearings, seal chamber, and mechanical seal.
2. **Increased Radial Thrusts** - Stresses on shaft and bearings.
3. **Heat Build Up** - Vaporization causing rotating parts to score or seize.
4. **Cavitation** - Damage to internal surfaces of mixer.



WARNING

If running clearances have enlarged due to wear, seizure may not take place and continued operation under these conditions may create an explosive hazard due to confined vapor under high pressure and temperature.

4

OPERATING UNDER FREEZING CONDITIONS

Exposure to freezing conditions while mixer is idle could cause liquid to freeze and damage the mixer. Liquid inside mixer should be drained. Liquid inside cooling coils, if supplied, should also be drained.

SHUTDOWN

1. Slowly close outlet valve.
2. Shut down and lock driver to prevent accidental rotation.



WARNING

When handling hazardous and/or toxic fluids, proper personal protective equipment should be worn. If mixer is being drained, precautions must be taken to prevent physical injury. Fluid must be handled and disposed of in conformance with applicable environmental regulations.

FINAL ALIGNMENT

1. Run the unit under actual operating conditions for a sufficient length of time to bring the mixer and driver up to operating temperature.
2. Shut down unit and lock out driver to prevent accidental rotation.
3. Check alignment while unit is still hot per alignment procedure outlined earlier.

INTERLOCKS

Mixer interlocks are additions to the feed pumping system interlocks and alarms and vary mill by mill. Typically, they depend upon what instruments are available.

The following are the basic guidelines for interlocks.

Steady pulp flow must be maintained before adding any chemicals or steam.

- Installation of flow and consistency measurement in the feed line is recommended.
- Chemicals or steam can be added only when the minimum flow and consistency levels are satisfied. The levels depend on the size of the mixer and pumping system.

The mixer must be running when steam or chemicals are added.

- It is possible, but not recommended, to pump through the mixer when it is not running, since mixing will not be effective and chemical usage will be high.

The mixer runs only when the feed pump is running.

- If the feed pump is down for more than five (5) minutes, the mixer will shut down.

Seal water is required to operate the mixer.

- The mixer has a cartridge mechanical seal with flush meter and alarm and cannot be operated without seal water.

NOTE: Some mixers have a single mechanical seal instead of the double seal.

- A low seal water flow alarm is recommended should the seal water flow fall below 50% of the set flow rate.

In C/D stage, dry chlorine cannot be added alone.



CAUTION

In C/D stage, the mixer material is titanium and dry chlorine will destroy this material!

- Chlorine has to be mixed with chlorine dioxide or water before it enters into the chemical addition pipe of the mixer.

PREVENTIVE MAINTENANCE

GENERAL COMMENTS	25
MAINTENANCE SCHEDULE	25
MAINTENANCE OF BEARINGS	26
Oil Lubricated Bearings	26
Grease Lubricated Bearings	27
MAINTENANCE OF SHAFT SEALS	28
ROTOR AXIAL CLEARANCE SETTING.	28
Dial Indicator Method	28
Feeler Gauge Method.	29
Mixer Washdown.	29
TROUBLESHOOTING	30

GENERAL COMMENTS

A routine maintenance program can extend the life of your mixer. Well maintained equipment will last longer and require fewer repairs. You should keep maintenance records, this will help pinpoint potential causes of problems.

MAINTENANCE SCHEDULE

Routine Maintenance

- Bearing lubrication
- Seal Monitoring
- Vibration analysis
- Temperature monitoring

Routine Inspections

- Check level and condition of oil through sight glass on bearing housing.
- Check for unusual noise, vibration and bearing temperatures.
- Inspect mixer and piping for leaks.
- Check seal chamber leakage.
- Mechanical Seal: Should be no leakage.

Quarterly Inspections

- Check foundation and hold-down bolts for tightness.
- Oil should be changed at least every 3 months or more often if there are any adverse atmospheric conditions or other conditions which might contaminate or break down the oil.
- Grease lubricated bearings should be regreased every 3 months.

Annual Inspections

- Check mixer capacity, and power. If mixer performance does not satisfy your process requirements, the mixer should be disassembled and inspected. Worn parts should be replaced.

MAINTENANCE OF BEARINGS

OIL LUBRICATED BEARINGS

Oil lubricated bearings must be lubricated at the job site. Remove fill plug (408H) and add oil until level is at the center of the sight glass (319). Replace fill plug (Fig. 21).

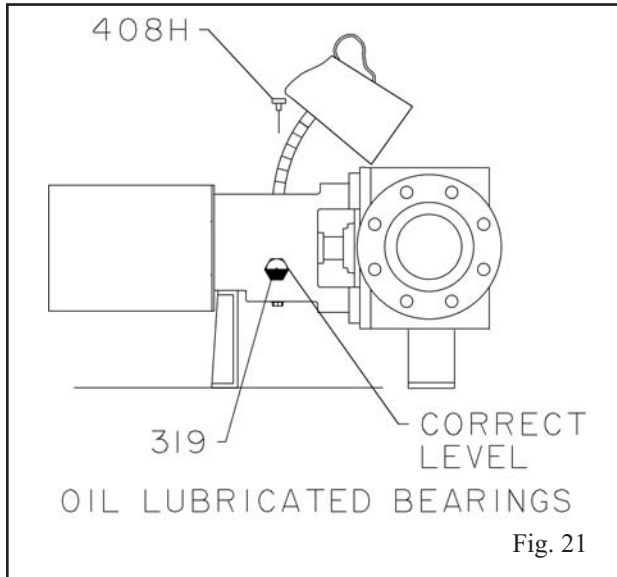

Change the oil after 200 hours for new bearings, thereafter every 2000 operating hours or 3 months (whichever comes first). Change more often if oil becomes contaminated with dirt or water. Oil change volumes are per *Table 3*.

Table 3 Oil Volumes		
Frame	Liters	Quarts
M	2	2.1
L	2	2.1
XL	3	3.2

A high quality turbine oil with rust and oxidation inhibitors should be used. For the majority of operational conditions, bearing temperatures will run between 60°C (140°F) and 82°C (180°F). In this range, an oil of ISO viscosity grade 68 at 40°C (105°F) is recommended. If bearing temperatures exceed 82°C (180°F), use of ISO viscosity grade 100 is recommended.

**Table 4
Lubricating Oil Requirements**

	Bearing temperature below 82°C (180° F)	Bearing temperature above 82°C (180° F)
ISO Grade	VG 68	VG 100
Approx. SSU at 38°C (100°F)	300	470
DIN 51517	C68	C100
Kinematic viscosity at 40°C (105°F) mm ² /sec	68	100

Acceptable Oils

Exxon	Teresstic EP 68
Chevron	GTS Oil 68
Mobil	Mobil DTE 26 300 SSU @ 38°C (100°F)
Gulf	Gulf Harmony 68
Phillips	Mangus Oil Grade 315
Phillips	MM motor oil SAE 20-20W
Phillips	HDS motor oil SAE 20-20W

If the constant level oiler option is supplied, it was adjusted before leaving the factory (See *Operations Section* for details). Fill the outer bottle with oil and replace in the oiler housing. Oil reservoir in bearing frame is filled when oil remains visible in the bottle. Several fillings of the bottle may be required.

GREASE LUBRICATED BEARINGS

Grease lubricated bearings are pre-lubricated at the factory. We recommend regreasing bearings every 2000 operating hours or 3 months. Refer to *Table 5* for re-grease amounts.

**Table 5
Grease Amounts**

Frame	Initial Grease				Regrease ¹			
	Thrust (Angular Contact)		Radial (Cylindrical Roller)		Thrust (Angular Contact)		Radial (Cylindrical Roller)	
	Grams	Oz.	Grams	Oz.	Grams	Oz.	Grams	Oz.
M	290	10	180	7.0	115	4.0	70	2.5
L	475	17	280	10	200	7.0	115	4.0
XL	800	28	450	16	345	12.0	190	6.5

¹ Amount is based on purging half of the old grease from the housing reservoir.

Regrease Procedure:

NOTE: When regreasing, there is danger of impurities entering the bearing housing. The grease container, the greasing device, and fittings must be clean.

1. Wipe dirt from grease fittings.
2. Remove two (2) grease relief plugs (408C) (Fig. 22).

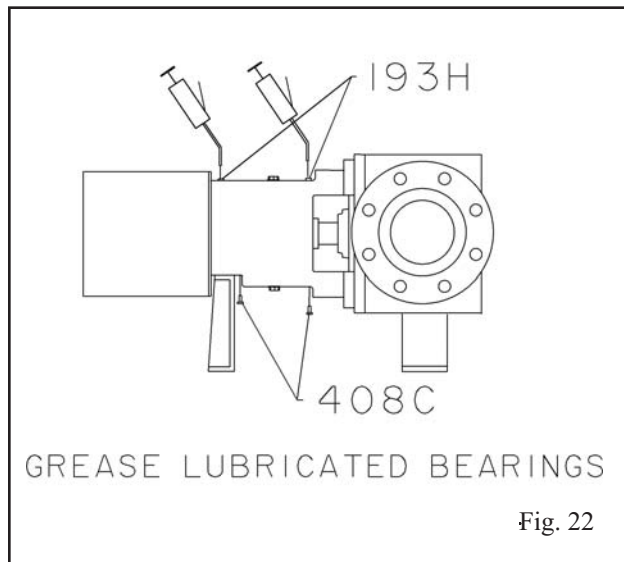

3. Fill both grease cavities through fittings with recommended grease until fresh grease comes out of the relief holes (408C).
4. Ensure frame seals (332A, 333B) are seated in bearing housing and, if not, press in place with drains located at the bottom.

5. Run mixer for about 2 hours or until grease stops emitting from housing and replace two (2) relief plugs (408C).

NOTE: The bearing temperature usually rises after regreasing due to an excess supply of grease. Temperatures will return to normal after mixer has run and purged the excess from the bearings, usually two to four hours.

For most operating conditions a lithium based mineral oil grease of NLGI consistency No. 2 is recommended. This grease is acceptable for fluid temperatures of -15°C to 110°C (5°F to 230°F). Bearing temperatures are generally about 25°C (45°F) higher than bearing housing outer surface temperature.

Acceptable Greases:

Mobil	Mobilux EP2	
Exxon	Unirex N2	
Texaco	Multifak 2	
Shell	Alvania 2 EP	Grease 2
Sunoco	Multipurpose EP	
SKF	LGMT 2	



CAUTION

Never mix greases of different consistency (NLGI 1 or 3 with NLGI 2) or different thickener soaps (sodium or calcium with lithium). The consistency usually becomes softer and will not provide adequate lubrication to the bearings.

For operating temperatures above 110°C (230°F) the bearings should be lubricated with a high temperature grease. Mineral oil greases should have oxidation stabilizers and a consistency of NLGI 3.

Acceptable Greases:

Exxon	Unirex N3
SKF	LGHT3

NOTE: If these greases are used, disassemble the bearing housing, degrease the bearings and housing prior to greasing.

MAINTENANCE OF SHAFT SEALS

MECHANICAL SEALS

Separate seal manufacturer's drawings are included with the mixer data package. Seals are installed and adjusted at the factory. Manufacturer's drawings should be filed for future use in maintaining seal and in adjusting seal when mixer is disassembled. To properly prepare seal for operation, various cooling and flushing lines may have to be connected. Connect cooling and flushing lines to seal as directed in manufacturer's instructions.

Mixers with cartridge mechanical seals utilize the TaperBore™ PLUS seal chamber arrangement. The TaperBore™ PLUS, in conjunction with a cartridge seal, simplifies installation and setting of seals.

The life of a mechanical seal depends on various factors such as cleanliness of the liquid handled and its lubricating properties. Due to the diversity of operating conditions it is, however, not possible to give definite indications as to its life.



WARNING

Never operate the mixer without liquid supplied to mechanical seal. Running a mechanical seal dry, even for a few seconds, can cause seal damage and must be avoided. Physical injury can occur if mechanical seal fails.

NOTE: For pumps supplied with cartridge mechanical seals, be sure the set screws in the seal locking ring have been tightened and the centering clips removed prior to startup. Failure to take these steps could result in damage to the mechanical seal or shaft sleeve.

ROTOR AXIAL CLEARANCE SETTING



WARNING

Lock out driver power to prevent accidental start-up and physical injury.

NOTE: For pumps or back pull-out assemblies supplied with cartridge mechanical seals, the centering tabs must be in place and tightened, and the set screw collar loosened. Failure to take these steps could result in damage to the mechanical seal or shaft sleeve.

A change in mixer performance may be noted over time by a decrease in brightness. Performance can usually be renewed by adjusting the rotor clearance. The total axial adjustment of the rotor between the casing and the seal chamber is approximately 5 mm (0.200 in). The rotor should be centered in the casing.

DIAL INDICATOR METHOD

1. Remove coupling guard.
2. Set indicator so that the button contacts either the shaft end or the face of the coupling (Fig. 23).
3. Loosen jam nuts (423B) on jack bolts (370D) and back bolts out about two turns.
4. Tighten each locking bolt (370C) evenly, drawing the bearing housing (134A) towards the bearing frame (228) until the rotating assembly bottoms out.
5. Set indicator to zero and back locking bolt (370C) out several turns.
6. Thread adjuster bolts (370D) in until they contact the bearing frame (228) evenly. Tighten the jack bolts evenly (about one flat at a time), backing the bearing housing (134A) away from the bearing frame until the rotating assembly contacts the seal chamber cover (184).
7. Record reading on dial indicator.
8. Divide "Total Travel" reading (determined in the previous step) by 2 and adjust the dial indicator to that number.
9. Loosen jack bolts (371A) several turns.
10. Tighten locking bolts (370C) evenly until dial indicator reading is "0".
11. Evenly tighten jack bolts (371A), then locking bolts (370C), keeping indicator reading at "0".
12. Tighten jam nuts (423B).
13. Check shaft for free turning.
14. Replace coupling guard.

FEELER GAUGE METHOD

1. Remove coupling guard.

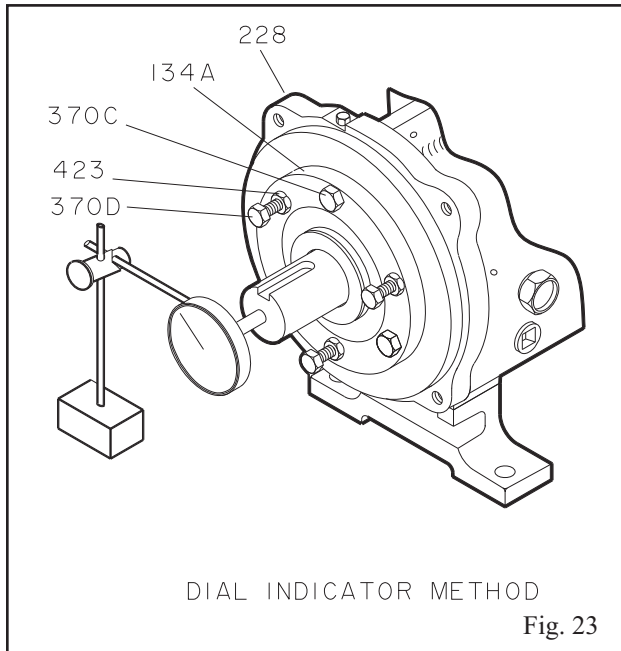

2. Loosen jam nuts (423B) on adjuster bolts (371A) and back bolts out about two turns.
3. Tighten locking bolts (370C) evenly, drawing bearing housing (134A) towards frame (228) until rotating assembly bottoms out.
4. With a set of feeler gauges, measure and record the gap between the bearing housing (134A) and the bearing frame (228) (Fig. 24).
5. Back locking bolts (370C) off a couple of turns.
6. Thread jack bolts (371A) in until they contact the bearing frame (228) evenly. Tighten the jack bolts evenly (about one flat at a time), backing the bearing housing (134A) away from the bearing frame until the rotating assembly contacts the seal chamber cover (184).
7. Using the feeler gauges, measure and record the gap between the bearing housing (134A) and the bearing frame (228).
8. Average the two gap measurements and set the feeler gauge stack to that number.
9. Loosen jack bolts (371A) several turns.

10. Insert feeler gauge stack into gap between bearing housing (134A) and bearing frame (228). Tighten the locking bolts (370C) evenly until bearing housing contacts the feeler gauge stack.
11. Evenly tighten jack bolts (371A), then locking bolts (370C) while assuring that the feeler gauge does not bind or become loose.
12. Tighten jam nuts (423B).
13. Check shaft for free turning.
14. Replace coupling guard.

NOTE: For pumps supplied with cartridge mechanical seals, be sure the set screws in the seal locking ring have been tightened and the centering clips removed prior to startup. Failure to take these steps could result in damage to the mechanical seal or shaft sleeve.

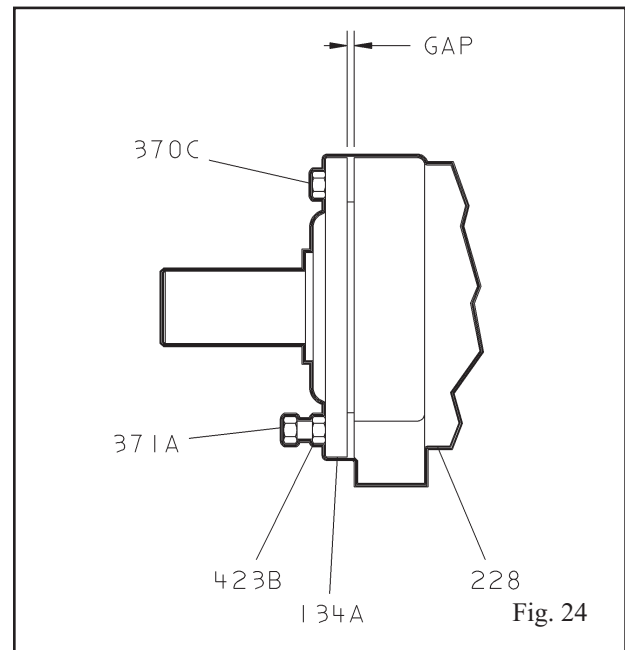

MIXER WASHDOWN

These mixers are designed to prevent liquid from entering the bearing frame. Care should be taken, however, to avoid spraying a high pressure stream directly at the labyrinth frame seals.

**Table 6
TROUBLESHOOTING**

Problem	Probable Cause	Remedy
Bearings run hot.	Improper alignment.	Re-align mixer and driver.
	Improper lubrication.	Check lubricant for suitability and level.
	Lube cooling.	Check cooling system.
Mixer is noisy or vibrates.	Improper mixer/driver alignment.	Align shafts.
	Partly clogged rotor causing imbalance.	Back-flush mixer to clean rotor.
	Broken or bent rotor or shaft.	Replace as required.
	Foundation not rigid.	Tighten hold down bolts of mixer and motor or adjust stilts.
	Worn bearings.	Replace.
	Inlet or outlet piping not anchored or properly supported.	Anchor per Hydraulic Institute Standards Manual recommendations
	Mixer is cavitating.	Locate and correct system problem. May have insufficient back pressure on mixer.
Excessive leakage from seal chamber.	Worn mechanical seal parts.	Replace worn parts.
	Overheating mechanical seal.	Check lubrication and cooling lines.
	Shaft sleeve scored.	Remachine or replace as required.
Motor requires excessive power.	Liquid heavier than expected.	Check specific gravity and viscosity.
	Rotating parts bind.	Check internal wearing parts for proper clearances.

DISASSEMBLY & REASSEMBLY

REQUIRED TOOLS	31
PREPARATION FOR DISASSEMBLY	31
DISASSEMBLY	32
INSPECTIONS	34
REASSEMBLY	35

REQUIRED TOOLS

- Hoist and Strap
- Socket Sizes (mm): 12, 14, 16, 19, 20
- Torque Wrench for reassembly
- Wrench Sizes (mm): 12, 16, 20
- Allen Wrenches (mm): 12, 14, 16, 19, 22
- Pry Bars
- Induction Bearing Heater
- Feeler Gauges
- Dial Indicator
- Cleaning Agents

PREPARATION FOR DISASSEMBLY



WARNING

Mixers may handle hazardous and/or toxic fluids. Skin and eye protection are required. Precautions must be taken to prevent injury or environmental contamination.

NOTE: Before disassembling the mixer for overhaul, ensure all replacement parts are available.

1. Lock out power supply to driver.
2. Shut off all valves controlling flow to and from mixer.
3. Drain liquid from piping, flush mixer if necessary.
4. Disconnect all auxiliary tubing and piping.
5. Remove coupling guard (Fig. 25).
6. Disconnect coupling (Fig. 25).
7. Either remove mixer coupling hub or move hub down shaft to bearing frame.

8. If unit is oil lubricated, drain oil from bearing frame by removing bearing frame drain plug (408B). Replace plug after oil is drained.

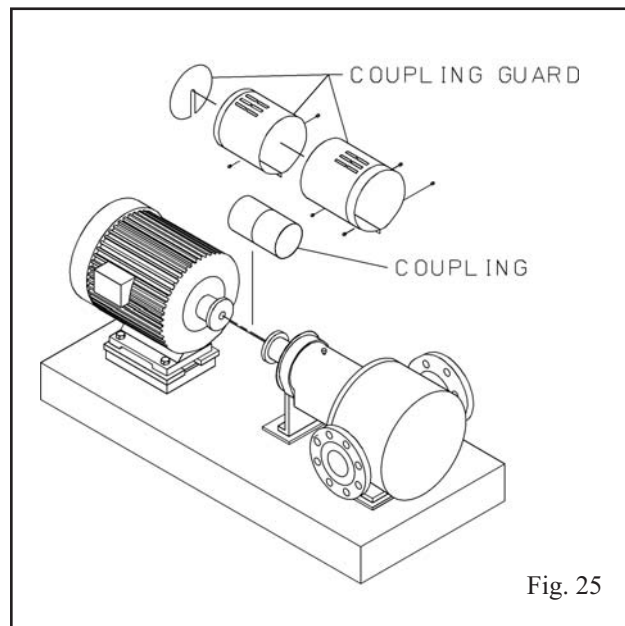

Fig. 25

DISASSEMBLY

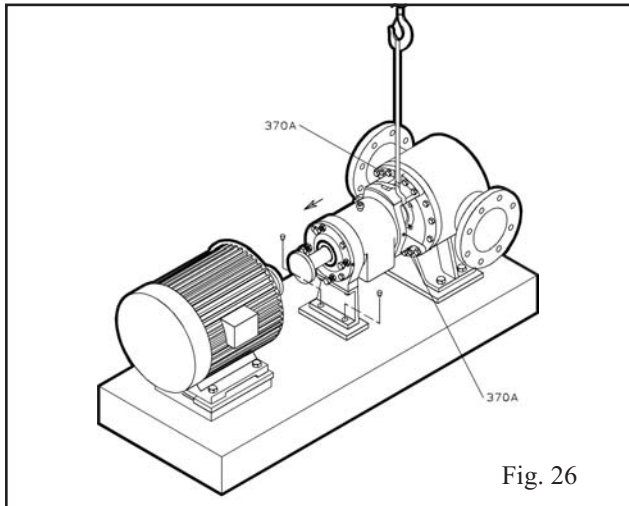

Fig. 26

1. Place sling from hoist around bearing frame (228) (Fig. 26).
2. Remove bearing frame foot hold-down bolts.
3. Remove six (6) casing bolts (370A, casing- to-seal chamber) and eight (8) casing bolts (469Z, frame-to-seal chamber to casing) (Fig. 26).
4. Use jack bolts (418) to remove the back pullout.

REMOVAL OF ROTOR

1. Secure back pullout firmly to bench.
2. Lock shaft (122) to prevent turning and remove rotor nut set screws (222S), rotor nut, and O-ring (Fig. 27).
3. Pry rotor (101) off shaft (182) using two bars opposite each other, placed between cover and rotor shroud. Another method of removing the rotor is using a rotor puller (Fig. 28).

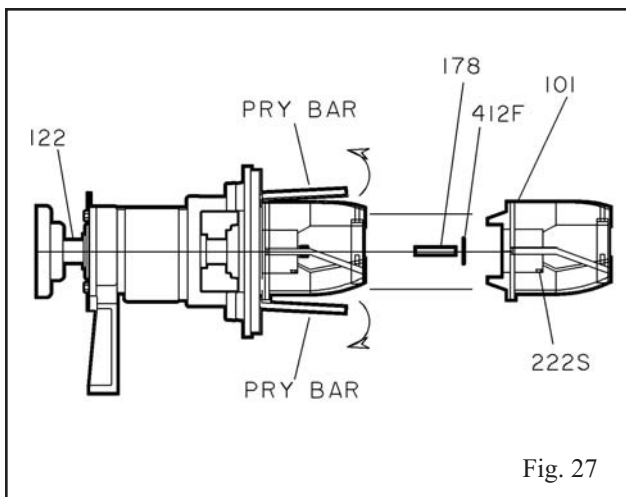

Fig. 27

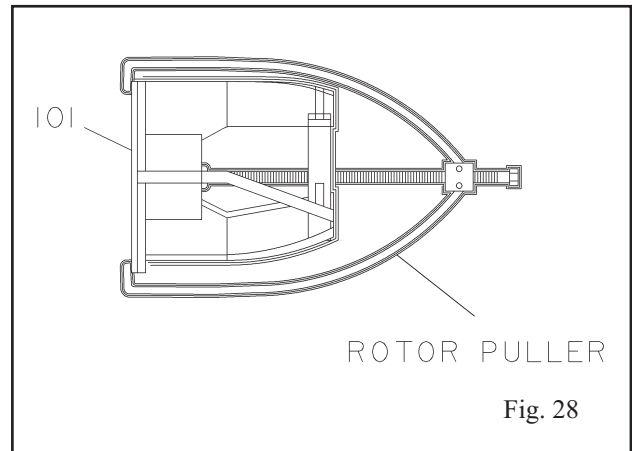

Fig. 28



WARNING

Do not use heat on the rotor to help remove, severe bodily injury could occur.



CAUTION

In order to prevent rotor damage, use pry points under rotor vanes.

REMOVAL OF TAPERBORE™ PLUS SEAL CHAMBER AND MECHANICAL SEAL

1. Re-engage mechanical seal setting clips (Fig. 29).

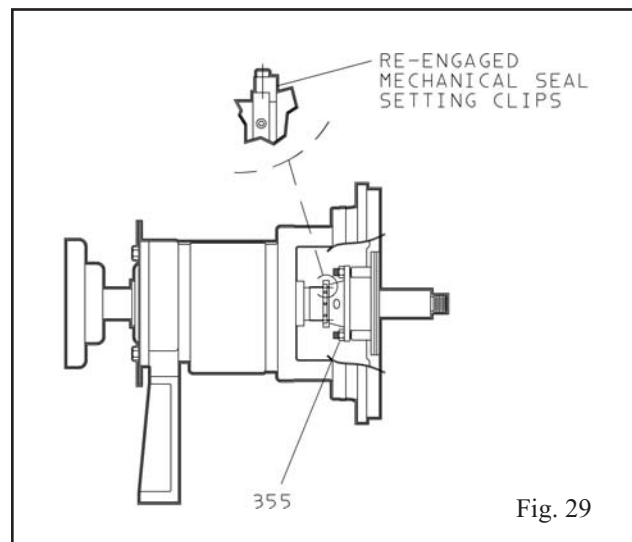
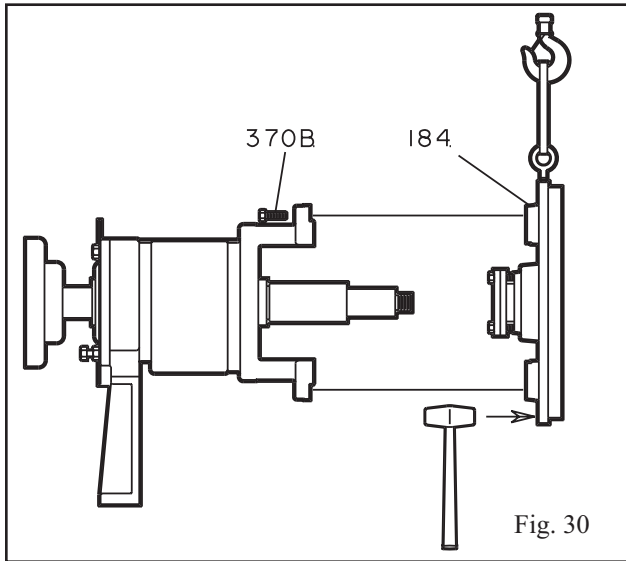

Fig. 29

- Thread a 10 mm eye bolt into the tapped hole provided in the seal chamber (184) and sling to a hoist (Fig. 30).



- Remove the two (2) hex head bolts (370B) from the seal chamber (184) (Fig. 30).
- Gently tap the seal chamber (184) with cartridge seal and mixer sleeve from the frame (228) using a soft blow hammer on the dry side of the cover (Fig. 30).
- Remove the four (4) hex nuts (355) and washers (354) from the seal gland plate.
- Loosen the set screws on the seal drive collar and slide the mixer sleeve (126) out of the seal.
- Service per the seal manufacturer's instructions.



WARNING

Seal chambers are heavy. Use proper support to avoid personal injury.

DISASSEMBLY OF BEARING FRAME

- Secure bearing frame assembly firmly to a work bench.
- Remove coupling hub from shaft (122) by loosening set screw (if provided) and using a puller (Fig. 31).
- Remove shaft key (400) (Fig. 31).
- Remove coupling guard end plate by removing bearing housing adjuster screws (370C) (Fig. 31).
- Remove labyrinth shaft seal assemblies (332A, 333A) from each end of frame (Fig. 31).

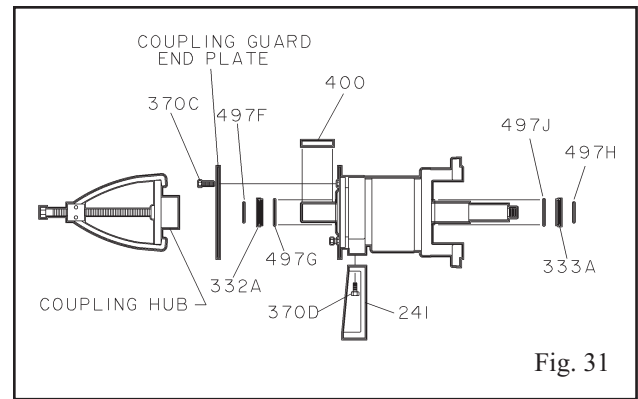

- Slide rotating element out of frame (228). If needed, tap rotor end of shaft with a soft blow hammer to assist in removal (Fig. 32).

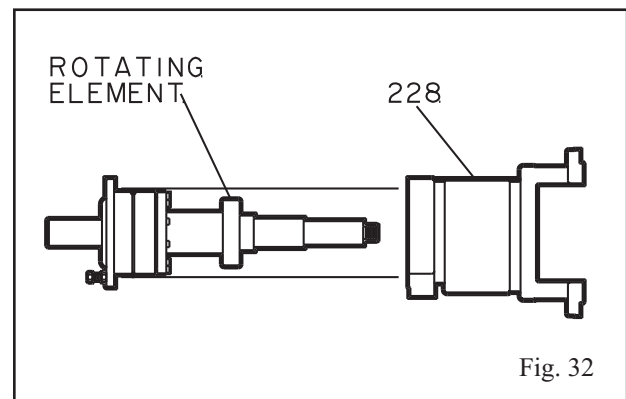

WARNING

Support both ends of shaft to prevent rotating element from dropping when bearings are disengaged from bores.

- Radial end cover (109A) is installed permanently at factory and should not require removal.
- Remove thrust bearing retainer ring (253B) by removing socket head cap screws (236A) (Fig. 33).

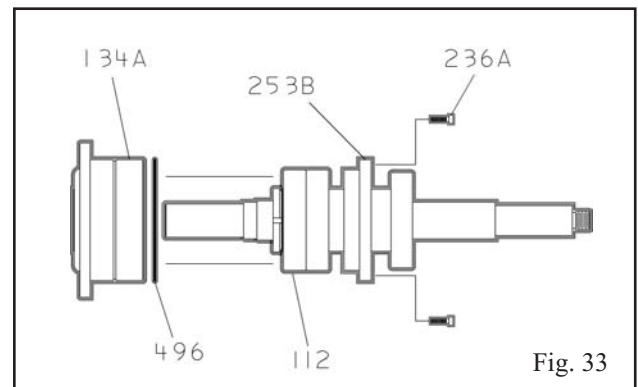

- Slide thrust bearing housing (134A) off thrust bearings (112) (Fig. 33).

10. Disengage thrust bearing lock washer (382) from locknut (136) and remove both from shaft (122) (Fig 34).
11. Remove bearings (112, 409) from shaft (122) using a suitable puller that only contacts inner races of bearings (Fig. 34).

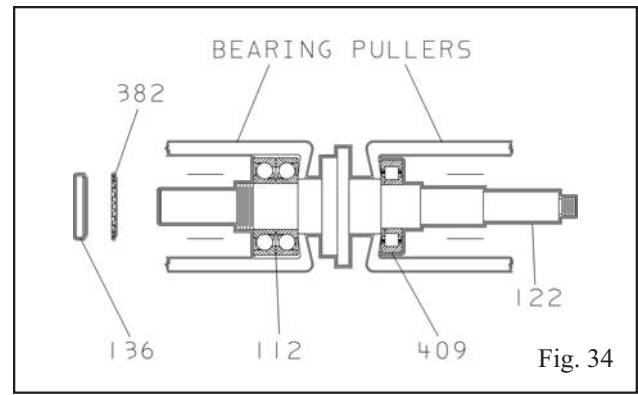

Fig. 34

INSPECTIONS

CASING

1. Thoroughly clean gasket surfaces and alignment fits to remove rust and debris.
2. Inspect for any unusual erosive wear inside casing.

ROTOR

1. Inspect leading and trailing edges of vanes for pitting, and erosion or corrosion damage.
2. Inspect keyway and bores for damage.

SEAL CHAMBER

1. Thoroughly clean gasket surfaces and fits to remove rust and debris.
2. Inspect surface for pitting, and erosion or corrosion damage.

BEARING FRAME

1. Inspect frame and frame foot for cracks.
2. Inspect for corrosion or pitting if frame has been exposed to the fluid.
3. Inspect frame bearing bores per Table 7.
4. Inspect labyrinth seal o-rings for cuts and cracks.
5. Inspect shafts and sleeves for wear.

**Table 7
Bearing Frame**

GROUP	BEARING	Maximum Bearing Frame (228) Bore mm(inch)	Maximum Bearing Housing (134A) Bore mm (inch)
M	Thrust	160.02 (6.3002)	130.03 (5.1191)
	Radial	130.03 (5.1191)	
L	Thrust	200.15 (7.8752)	160.02 (6.3002)
	Radial	150.11 (5.9065)	
XL	Thrust	240.03 (9.4500)	189.99 (7.4815)
	Radial	180.09 (7.0876)	

**Table 8
Bearing Sizes**

GROUP	THRUST BEARING	RADIAL BEARING
M	7312BECBY	NUP312ECP
L	7315BECBY	NUP314ECP
XL	7318BECBY	NUP317ECP

REASSEMBLY

Specifications

Table 9 - Model 3501 Fastener Information

Item No.	Qty per Mixer	Part Name	Group	Construction	Goulds Part No.	Thread Size	Hex Size (mm)	Torque Value (See Notes 1 - 3)	
								N-m	lb-ft
—	3	Hex Head Cap Screw – Coupling Guard (Not shown)	All	All	A02818A89 2441	M10 x 1.50	17	--	--
—	3	Nut, Hex, Coupling Guard (Not shown)	All	All	A02089A10 2441	M10 x 1.50	17	13	10
136	1	Locknut, Bearing	M	All	8601-0012	N12	N/A	112	83
			L		8601-3015	AN15	N/A	214	158
			XL		8601-3018	AN18	N/A	356	263
222S	2	Set Screw, Impeller Nut	All	316ss	A02819A74 2440	M10 x 1.50	5 Internal	13	10
				Titanium	A02819A74 2156	M10 x 1.50	5 Internal	14	11
236A	8	Socket Head Cap Screw – Bearing Retainer to Bearing Housing	M	All	A05092A47 2443	M6 x 1.00	5 Internal	13	10
	10		L and XL		A03723A82 2443	M10 x 1.50	8 Internal	63	46
304	1	Nut, Impeller	M	316ss	B02151A04 1203	M27 x 3.00	41	274	202
				Titanium	B04216A02 2156	M27 x 3.00	41	301	222
			L	316ss	B04168A 2229	M27 x 3.00	41	274	202
				Titanium	B04168A 2156	M27 x 3.00	41	301	222
			XL	316ss	B02152A04 1203	M42 x 4.50	65	1038	766
				Titanium	B04216A04 2156	M42 x 4.50	65	1142	842
353	4	Stud, Gland	M	All	A02815A39 2441	M12 x 1.75	N/A	22	16
			L and XL		A02815A40 2441	M16 x 2.00	N/A	55	41
355	4	Nut, Hex, Gland	M	All	A02089A12 2441	M12 x 1.75	19	22	16
			L and XL		A02089A16 2441	M16 x 2.00	24	55	41
370A	6	Hex Head Cap Screw – Casing to Seal Chamber (Not shown)	M	All	A02818A106 2441	M12 x 1.75	19	22	16
			L and XL		A02818A128 2441	M16 x 2.00	24	55	41
370B	2	Hex Head Cap Screw – Seal Chamber to Frame (Not shown)	M	All	A02818A86 2442	M10 x 1.50	17	38	28
			L and XL		A02818A107 2442	M12 x 1.75	19	66	49
370C	3	Hex Head Cap Screw – Housing to Frame	M	All	A02817A72 2442	M12 x 1.75	19	66	49
	4		L and XL		A02818A128 2442	M16 x 2.00	24	164	121
370D	2	Hex Head Cap Screw – Frame Foot to Frame	M	All	A02818A102 2442	M12 x 1.75	19	66	49
			L and XL		A02818A124 2442	M16 x 2.00	24	164	121
370F	4	Hex Head Cap Screw – Casing Foot to Casing (Not shown)	M	All	A02818A102 2442	M12 x 1.75	19	66	49
			L		A02818A124 2442	M16 x 2.00	24	164	121
371A	3	Hex Tap Bolt – Adjustment	M	All	A02818A106 2442	M12 x 1.75	19	66	49
	4		L and XL		A02818A128 2442	M16 x 2.00	24	164	121
372V	4	Hex Head Cap Screw - Casing to Baseplate (Not shown)	M	Carbon Steel	A02818A104 2442	M12 x 1.75	19	66	49
				316ss	A02818A104 2440	M12 x 1.75	19	23	17
			L	Carbon Steel	A02818A125 2442	M16 x 2.00	24	164	121
				316ss	A02818A125 2440	M16 x 2.00	24	56	41
			XL	Carbon Steel	A02818A144 2442	M20 x 2.50	30	331	244
				316ss	A02818A144 2440	M20 x 2.50	30	108	80
372W	4	Hex Head Cap Screw - Frame Foot to Baseplate (Not shown)	M	Carbon Steel	A02818A104 2442	M12 x 1.75	19	66	49
				316ss	A02818A104 2440	M12 x 1.75	19	23	17
			L	Carbon Steel	A02818A125 2442	M16 x 2.00	24	164	121
				316ss	A02818A125 2440	M16 x 2.00	24	56	41
			XL	Carbon Steel	A02818A144 2442	M20 x 2.50	30	331	244
				316ss	A02818A144 2440	M20 x 2.50	30	108	80
418	2	Hex Head Cap Screw – Jacking	M	All	A02818A89 2442	M10 x 1.50	17	38	28
			L and XL		A02818A107 2442	M12 x 1.75	19	66	49
423B	3	Nut, Hex – Adjusting	M	All	A02089A12 2442	M12 x 1.75	19	66	49
	4		L and XL		A02089A16 2442	M16 x 2.00	24	164	121
469Z	8	Hex Head Cap Screw – Frame to Seal Chamber to Casing	M	All	A02818A111 2441	M12 x 1.75	19	22	16
			L and XL		A02818A131 2441	M16 x 2.00	24	164	121

Note: 1. Torque valves are based on standard lubrication.

2. If threads have no lubrication (i.e. -dry threads), torque values should be increased by 33 %.

3. If threads have been lubricated with a performance lubricant (e.g. - NeverSeez®), torque values should be decreased by 50%.

REASSEMBLY OF BEARING FRAME

NOTE: An induction type bearing heater is required to expand bearings to ease their installation on shaft. Bearings should be heated to approximately 100°C (212°F).



CAUTION

Do not use a flame to heat bearings, this will damage bearing surfaces.

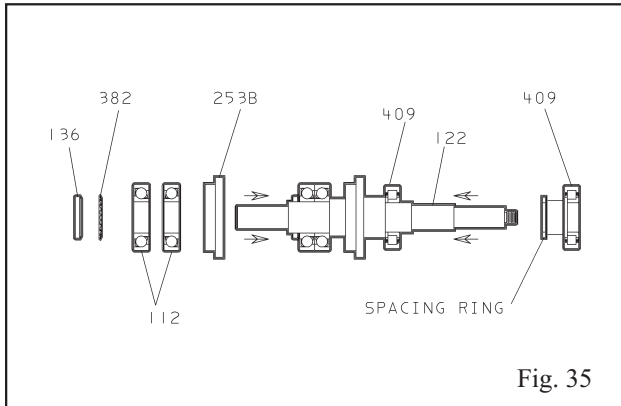

Fig. 35

NOTE: Refer to Table 9 for the torque values for all fasteners.

1. After heating, install radial bearing (409) onto shaft (122) ensuring spacing ring is placed between shaft shoulder and inner race (Fig. 36).

NOTE: Care must be taken to keep inner race together with roller assembly during installation.

2. Place thrust bearing retainer ring (253B) on shaft (122) between bearing fits with small diameter facing coupling end.
3. Determine orientation of angular contact thrust bearings (112) for back-to-back mounting. This is with the thick shoulders of outer races together.
4. After heating, slide angular contact duplex set (112) onto shaft (122), maintaining the correct orientation from Step 3. Push inner races firmly together against the shaft shoulder until they cool and lock into place.
5. After bearings have cooled, place lockwasher (382) on shaft (122) and install bearing locknut (136).
6. Tighten bearing locknut (136) firmly with a spanner wrench, clamping bearing (112) against shaft (122) shoulder.
7. Bend lockwasher (382) tang into a slot that lines up on bearing locknut (136).
8. If bearing lubrication is grease, hand pack all three bearings with grease.

9. Lubricate and install O-ring (496) on thrust bearing housing (134A).
10. Slide thrust bearing housing (134A) over thrust bearing (112) (Fig. 35).

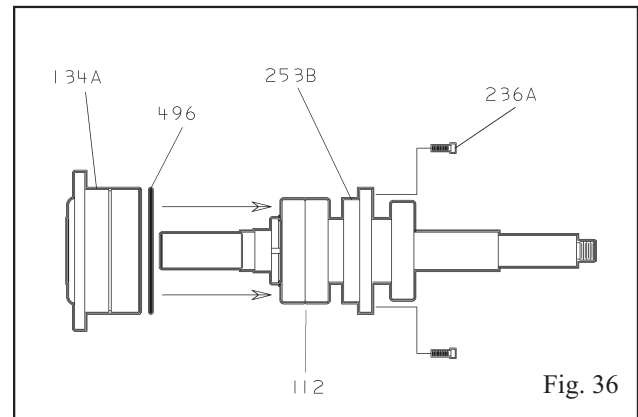

Fig. 36

11. Attach thrust bearing retainer ring (253B) to thrust bearing housing (134A) with socket head cap screws (236A). Tighten firmly in a cross bolt pattern to ensure even contact with bearing races (Figs. 35 and 36).

NOTE: There will be a gap of approximately 3-4 mm (.12-16 in.) between retainer and housing.

12. Prepare bearing frame (228) for either oil or grease oil lubrication as follows:

- **Oil Lubrication** - Ensure oil return is fully open (No plug) (Fig. 37 and 38).

NOTE: If changing lubrication from grease to oil, remove accumulated grease from oil return after plug is removed.

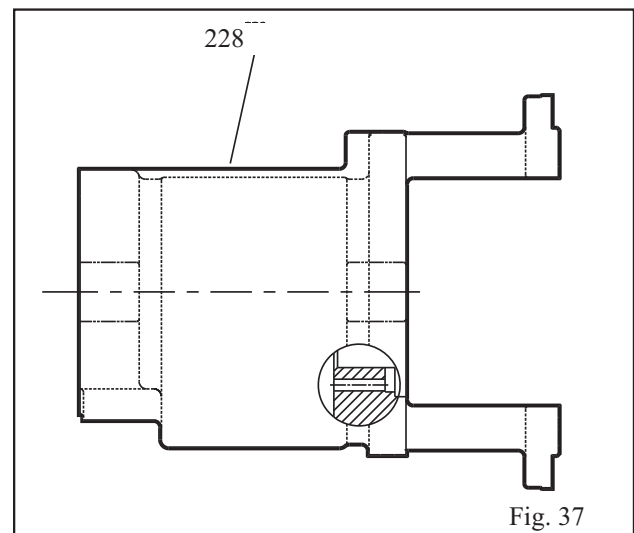

Fig. 37

- **Grease Lubrication** - Ensure plug (370E) is installed in radial end oil return (Fig. 38).

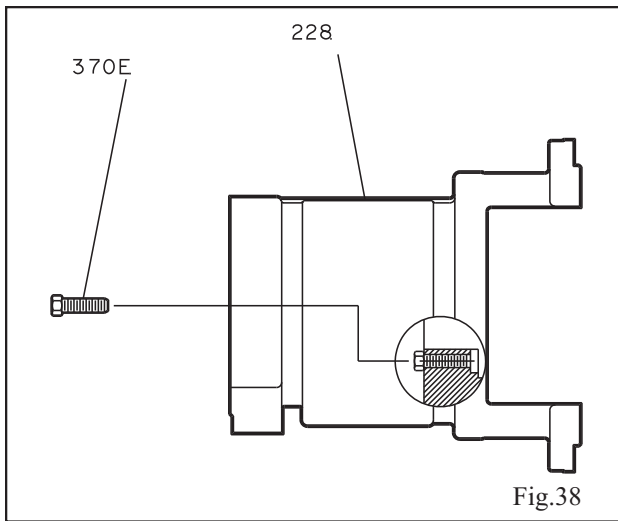

Fig.38

13. If radial end cover (109A) was removed, degrease contact surfaces and those in bearing frame (228) and apply Loctite 518 to the outer diameter of cover.
14. Tap radial end cover (109A) in place using a soft blow hammer.
15. Lightly lubricate bores of bearing frame (228), outer diameters of radial bearing (409) and thrust bearing housing (134A), and housing O-ring (496) with compatible oil or grease (Fig. 39).
16. Carefully insert rotating element into bearing frame (228).

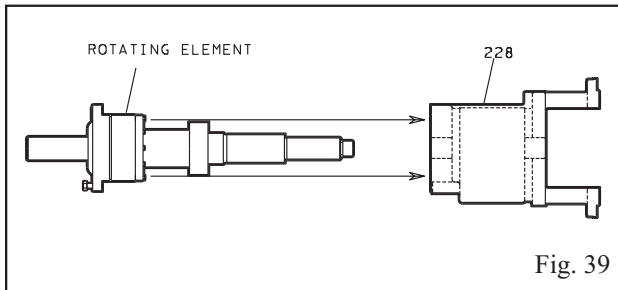

Fig. 39

17. Orient bearing housing (134A) properly for desired lubrication:

- **Oil Lubrication:** Orient bearing housing so the words “TOP OIL” are on top (Fig. 40).
- **Grease Lubrication:** Orient bearing housing so the words read “TOP GREASE” are on top (Fig. 40).

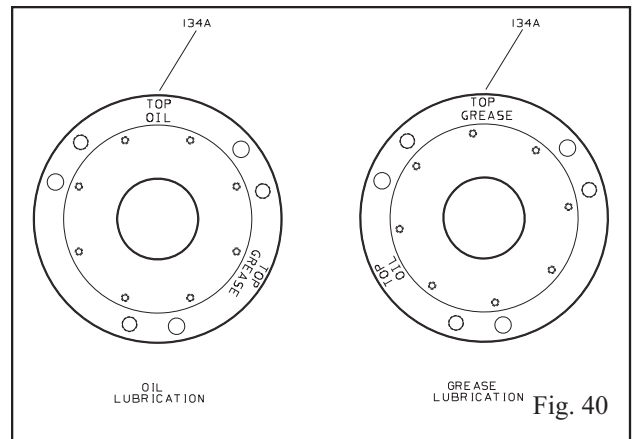

Fig. 40

18. Align holes in coupling guard end plate to bearing housing to frame holes in thrust bearing housing (134A) and install hex cap bolts (370C) (Fig. 41).
19. Adjust housing (134A) so there is a gap of approximately 3 mm (1/8 in.) between housing and bearing frame (228).

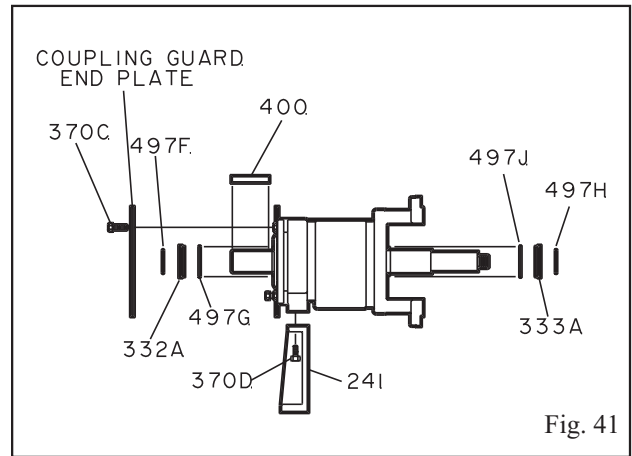
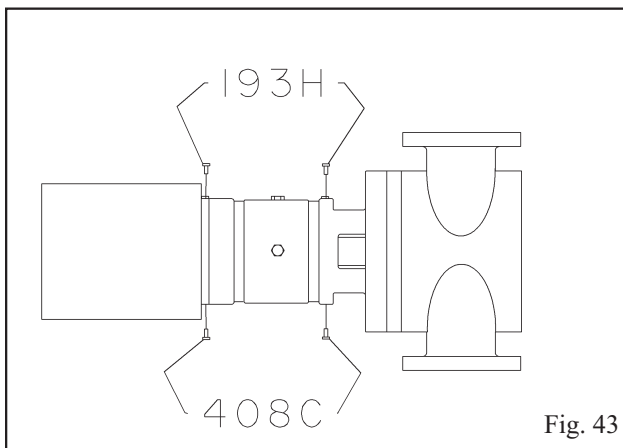
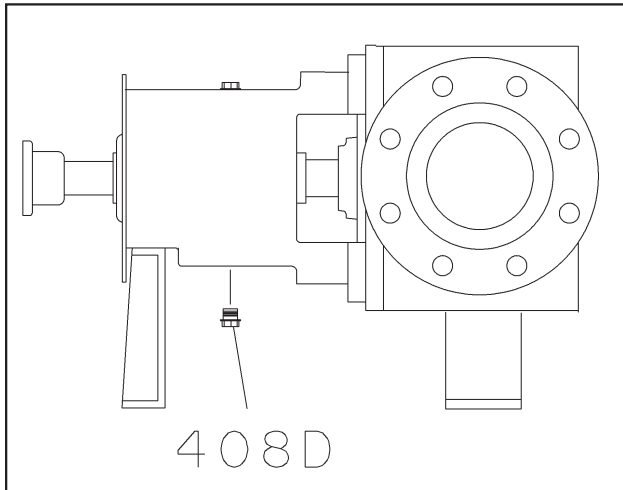

Fig. 41

20. Lubricate O-rings on labyrinth oil seals (332A and 333A).
21. Install thrust labyrinth oil seal (332A) into bore of thrust bearing housing (134A) until shoulder seats against housing.
22. Install radial labyrinth oil seal (333A) into bore of radial end cover (109A) until shoulder seats against cover.
23. Install oil fill plug (408H) into top of bearing frame (228).
24. Install shaft key (400) and coupling hub onto shaft (122).
25. Install frame foot (241) onto bearing frame (228) with hex head cap screws (370D).
26. **Oil Lubrication**
 - a. Install four plugs (408E) into bearing frame (228) as follows, based on viewing from coupling end (Figs. 42 and 43):

- two on right side (at coupling end)
 - one on left side
 - one on top at seal chamber end
- b. Install oil sight glass (319) on right side of bearing frame (228) as viewed from coupling end.
 - c. Install oil drain plug (408B) into bottom of bearing frame (228).
 - d. If equipped with a sight oiler (251), install on left side of bearing frame (228) as viewed from coupling end.



Grease Lubrication

- a. Install two grease fittings (193H) into bearing frame (228) as follows, based on viewing from coupling end (Fig. 43):
 - one on left side at coupling end
 - one on top at seal chamber end.
- b. Install two plugs (408C) into right side of bearing frame (228), based on viewing from coupling end.
- c. Install oil drain plug (408B) into bottom of bearing frame (228) (Fig. 42).

27. If equipped with an oil cooler, install cooler assembly into bearing frame (228), based on viewing from coupling end as follows (Fig. 44):

- a. Install one tube fitting with straight bore on left side of frame.
- b. Slide finned tube through the hole on right side of frame.
- c. Install reducer bushing on right side of frame .
- d. Thread a second tube fitting (with straight bore) into reducer bushing.
- e. Center tube in frame and tighten ferrule nuts on tube fittings.
- f. Install one tube fitting with a stepped bore on each end of tube and tighten ferrule nuts.

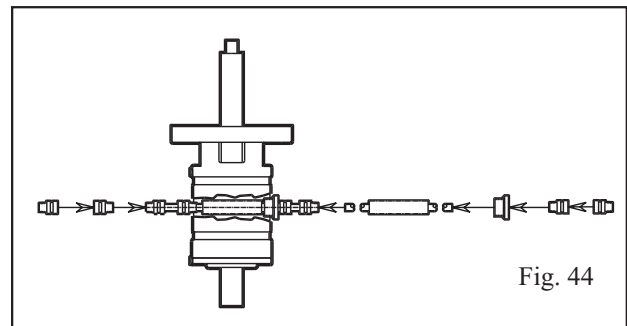

REASSEMBLY OF TAPERBORE™ PLUS SEAL CHAMBER AND MECHANICAL SEAL

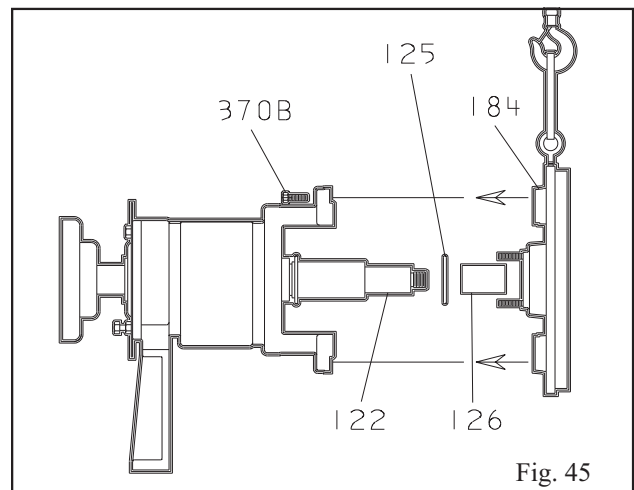

1. Apply a liberal amount of an anti-galling compound (Loctite "Nickel Anti-seize") to shaft sleeve (126) bore and shaft (122) (Fig. 45).
2. Slide sleeve (126) onto shaft (122).
3. Completely lubricate the O-ring in the bore of the mechanical seal sleeve.

4. Install cartridge seal on sleeve (126).
5. Rig lifting device to eyebolt in seal chamber (184) and install seal chamber (184) on bearing frame (228).
6. Install hex head bolts (370B).
7. Slide cartridge seal on gland studs (353). Assure that gland studs align with openings in gland, and that the tap connections are in the correct orientation.
8. Install gland stud washers (354) and nuts (355) and finger tighten the gland nuts. **Do not tighten** the nuts or set seal until after the mixer rotor is adjusted.
9. After the rotor is installed and clearance is set, secure the mechanical seal as follows:
 - a. Refer to mechanical seal drawing.
 - b. Tighten gland nuts (355) evenly.
 - c. Tighten set screws in drive collar while setting clips are engaged.
 - d. Remove setting clips.

INSTALLATION OF ROTOR

1. Install shaft key (178) on shaft (122) (Fig. 46).
2. Fit sleeve O-ring (412F) into groove on shaft sleeve (126).
3. Apply a liberal coating of an anti-galling compound (Loctite "Nickel Anti-seize") to mixer rotor (101) bore and shaft (122).

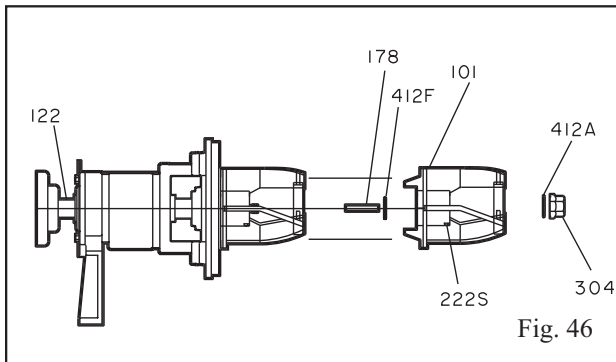

4. Slide mixer rotor (101) onto shaft (122). Ensure sleeve O-ring (412F) stays in groove.
5. Fit rotor nut O-ring (412A) into groove in rotor nut (304).
6. Degrease rotor nut (304) and shaft (122) threads and apply ND Industries VIBRA-TITE Formula 3 thread sealing compound to threads in nut.
7. Install rotor nut (304) on shaft (122).
8. Prevent coupling end of shaft from turning and torque rotor nut to specified amount on Table 9.



CAUTION

Failure to torque rotor nut can result in serious mechanical damage.

9. Apply ND Industries VIBRA-TITE Formula 3 thread sealing compound to rotor nut set screws (222S).
10. Install and tighten rotor nut set screws (222S).

INSTALLATION OF CASING FOOT AND ALIGNMENT PIN

NOTE: Model 3501 6" and 8" mixers require a casing foot (131). The 12" mixer does not. Model 3501 8" mixers require an alignment pin on the inlet flange to ensure that the chemical injection pipe (174) is properly oriented. The 6" and 12" mixers do not require the alignment pin.



WARNING

Mixer components are heavy. Proper methods of lifting and securing must be employed to avoid physical injury and/or equipment damage.

1. For 6" and 8" mixers, determine the correct orientation of the casing from the order documents. Model 3501 6" and 8" mixers have a transverse stationary vane in the casing (100) which must be oriented toward the chemical injection pipe (174). The 12" mixer does not (Fig. 46A).

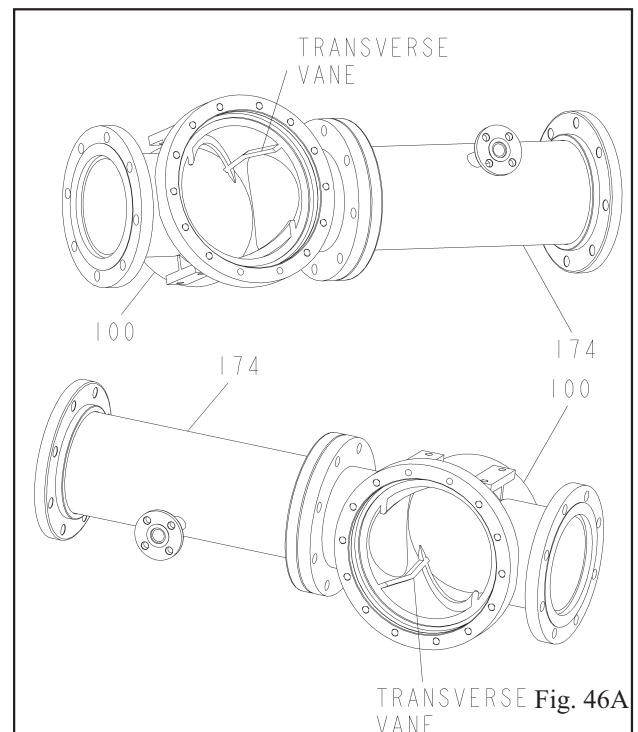

2. Align holes in casing foot (131) with tapped holes on appropriate casing (100) foot bosses. These are normally the holes facing the baseplate.

3. Install hex cap screws (370F) and tighten to torque value in Table A-1.
4. For 8" mixers, degrease threads in casing (100) inlet flange, and apply ND Industries VIBRA-TITE thread sealing compound to threads on alignment pin.
5. Install alignment pin (shank plug) into tapped hole in inlet flange and tighten.

INSTALLATION OF BACK PULL-OUT ASSEMBLY

NOTE: For pumps or back pull-out assemblies supplied with cartridge mechanical seals, the centering tabs must be in place and tightened, and the set screw collar loosened. Failure to take these steps could result in damage to the mechanical seal or shaft sleeve.

1. Adjust rotor (101) so gap between rear rotor shroud vanes and seal chamber (184) is approximately 0.5 mm (.02 in.).
2. Place casing gasket (351) on seal chamber (184).
3. Place sling from hoist around frame (228) (Fig. 47).
4. On a flat surface (baseplate or sturdy workbench), install back pull-out assembly into casing (100). Ensure casing foot (131), if supplied, and frame foot (241) are flat on the surface.
5. Hand tighten four equally spaced casing bolts (370A). Seat back pull-out into casing (100) - Do not tighten bolts yet.
6. Check total travel of rotor in casing. Assuming new parts are used, acceptable values are 3.3 - 5.8 mm (0.130-0.230 in.) of total travel. If outside of this range, worn parts, improper installation or too much pipe strain is present. Determine cause and correct.
7. If total travel is within criteria, tighten remaining casing bolts and torque to specified value in a cross bolt pattern. (Refer to Table 9).
8. Set rotor (101) axial clearance as described in Preventive Maintenance section.
9. Install and tighten casing foot nut to baseplate bolts (372V)
10. Determine gap, if any, between frame foot and baseplate with feeler gauges and shim accordingly.
11. Install and tighten frame to baseplate (372W)
12. Lubricate bearing frame assembly with oil or grease as described in Operation and Preventive Maintenance sections.
13. Rotate shaft (122) by hand to assure free rotation.

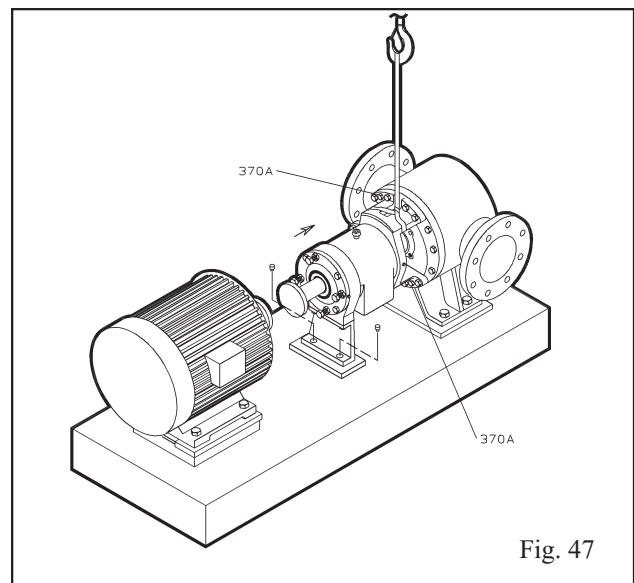

Fig. 47

14. Reinstall coupling hub.
15. Align mixer.
16. Reconnect coupling.
17. Install coupling guard (Fig. 48).
18. Reconnect all auxiliary piping.

NOTE: For pumps supplied with cartridge mechanical seals, be sure the set screws in the seal locking ring have been tightened and the centering clips removed prior to startup. Failure to take these steps could result in damage to the mechanical seal or shaft sleeve.

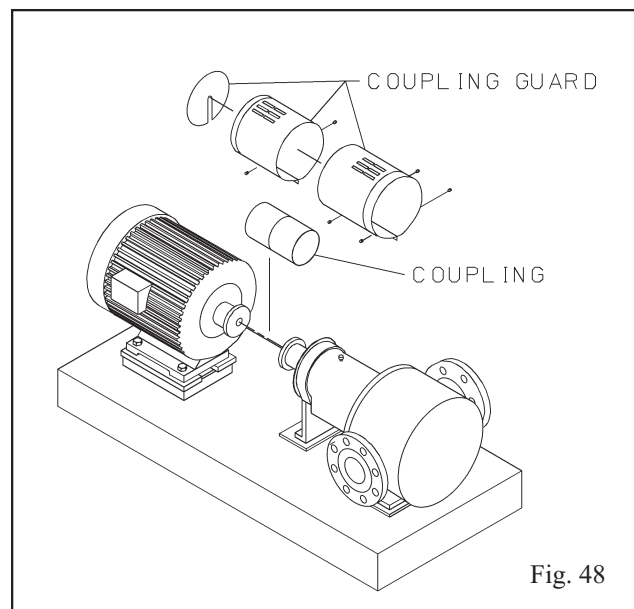

Fig. 48

SPARE PARTS

RECOMMENDED SPARE PARTS. 41
3501 MIXER CROSS SECTIONAL 42
3501 MIXER PARTS LIST WITH MATERIAL OF CONSTRUCTION . 43
HOW TO ORDER PARTS. 44

RECOMMENDED SPARE PARTS

To insure against possible long and costly downtime period, especially on critical services, it is advisable to have spare parts on hand.

MOST DESIRABLE SPARE PARTS

- Back Pull-out assembly, this is a group of assembled parts which includes all parts except the casing.
- Mechanical Seal item 383
- Gaskets and O-rings required for one mixer.

RECOMMENDED SPARE PARTS

- Mechanical Seal item 383
- Shaft Sleeve, item 126
- Bearing, items 112 & 409
- Rotor Nut, item 304
- Impeller Key, item 178
- Bearing Locknut, item 136

- Bearing Lockwasher, item 382
- Shaft, item 122
- Gaskets and O-rings required for one mixer.

MINIMUM RECOMMENDED SPARE PARTS

- Shaft Sleeve, item 126
- Bearing, items 112 & 409
- Bearing Locknut, item 136
- Bearing Lockwasher, item 382
- Rotor Nut, item 304
- Gaskets and O-rings required for one mixer.

Table 10
3501 MIXER PARTS LIST WITH MATERIALS OF CONSTRUCTION

Item No.	Qty Per Mixer	Part Name	Material	
			316SS	Titanium
100	1	Casing	316LSS	Titanium
101	1	Rotor	316LSS	Titanium
109A	1	Cover, End-Radial	Cast Iron	Cast Iron
112	2	Bearing, Thrust - Angular Contact	Steel	Steel
122	1	Shaft	Steel	Duplex
126	1	Shaft Sleeve	316SS	Titanium
131	1	Foot, Casing (Not Shown)	Steel	Steel
134A	1	Housing, Bearing	Cast Iron	Cast Iron
136	1	Locknut, Bearing	Steel	Steel
174	1	Pipe, Chemical Injection (Not Shown)	316LSS	Titanium
178	1	Impeller, Key	17- 4PH	17- 4PH
184	1	Seal Chamber	316SS	Titanium
222S	2	Set Screw, Impeller Nut	316LSS	Titanium
228	1	Frame, Bearing	Cast Iron	Cast Iron
236A	8 or 10	Socket Head Cap Screw - Bearing Retainer to Bearing Housing	Steel	Steel
241	1	Foot, Frame	Steel	Steel
253B	1	Retainer, Bearing	Cast Iron	Cast Iron
304	1	Nut, Impeller	316SS	Titanium
319	1	Window, Sight	Glass	Glass
332A	1	Seal, Labyrinth - Thrust	Bronze/Viton	Bronze/Viton
333A	1	Seal, Labyrinth - Radial	Bronze/Viton	Bronze/Viton
351	1	Gasket, Casing	Non-Asbestos	Non-Asbestos
353	4	Stud, Gland	304SS	304SS
354	4	Washer, Gland Stud	304SS	304SS
355	4	Nut, Gland	304SS	304SS
358H	1	Plug, Pipe, Oiler Tap (Not Shown)	Steel	Steel
360V	1	Gasket, Chemical Injection Pipe (Not Shown)	Non-Asbestos	Non-Asbestos
370A	6	Hex Head Cap Screw-Case to Seal Chamber (Not Shown)	304SS	304SS
370B	2	Hex Head Cap Screw-Seal Chamber to Frame (Not Shown)	Steel	Steel
370C	3 or 4	Hex Head Cap Screw-Housing to Frame	Steel	Steel
370D	2	Hex Head Cap Screw-Frame Foot to Frame	Steel	Steel
370F	4	Hex Head Cap Screw -- Casing Foot to Casing (Not Shown)	Steel	Steel
371A	3 or 4	Hex Tap Bolt-Adjustment	Steel	Steel
382	1	Lockwasher, Bearing	Steel	Steel
400	1	Key, Coupling (Not Shown)	Steel	Steel
408B	1	Plug, Drain	Steel	Steel
408E	4	Plug	Steel	Steel
408H	1	Plug, Oil Fill	Steel	Steel
409	1	Bearing, Roller	Steel	Steel
412A	1	O-ring, Impeller Nut	Teflon®	Teflon®
412F	1	O-ring, Shaft Sleeve	Teflon®	Teflon®
418	2	Hex Headd Cap Screw - Jacking	Steel	Steel
423B	3 or 4	Nut, Hex - Adjusting	Steel	Steel
469Z	8	Hex Head Cap Screw - Frame to Seal Chamber to Casing	304SS	304SS
496	1	O-ring, Housing	Buna-N	Buna-N

Notes: 1. Quantity of Item Number 236A is 8 for M group and 10 for L and XL groups.
2. Quantities of Item Numbers 370C, 371A and 423B are 3 for M group and 4 for L and XL groups.

HOW TO ORDER

**When ordering parts call
1-800-446-8537
or your local Goulds Representative**

EMERGENCY SERVICE

**Emergency parts service is available
24 hours/day, 365 days/year . . .
Call 1-800-446-8537**

Visit our Web site at www.gouldspumps.com

