



GENERAL INSTALLATION, OPERATION AND MAINTENANCE INSTRUCTIONS

MODEL 3900



## IMPORTANT SAFETY NOTICE

*To: Our Valued Customers*

User safety is a major focus in the design of our products. Following the precautions outlined in this manual will minimize your risk of injury.

ITT Goulds pumps will provide safe, trouble-free service when properly installed, maintained, and operated.

Safe installation, operation, and maintenance of ITT Goulds Pumps equipment are an essential end user responsibility. This *Pump Safety Manual* identifies specific safety risks that must be considered at all times during product life. Understanding and adhering to these safety warnings is mandatory to ensure personnel, property, and/or the environment will not be harmed. Adherence to these warnings alone, however, is not sufficient — it is anticipated that the end user will also comply with industry and corporate safety standards. Identifying and eliminating unsafe installation, operating and maintenance practices is the responsibility of all individuals involved in the installation, operation, and maintenance of industrial equipment.

Please take the time to review and understand the safe installation, operation, and maintenance guidelines outlined in this Pump Safety Manual and the Instruction, Operation, and Maintenance (IOM) manual. Current manuals are available at [www.gouldspumps.com/literature\\_ioms.html](http://www.gouldspumps.com/literature_ioms.html) or by contacting your nearest Goulds Pumps sales representative.

**These manuals must be read and understood before installation and start-up.**

For additional information, contact your nearest Goulds Pumps sales representative or visit our Web site at [www.gouldspumps.com](http://www.gouldspumps.com).

# SAFETY WARNINGS

Specific to pumping equipment, significant risks bear reinforcement above and beyond normal safety precautions.

---

 **WARNING**

---

A pump is a pressure vessel with rotating parts that can be hazardous. Any pressure vessel can explode, rupture, or discharge its contents if sufficiently over pressurized causing death, personal injury, property damage, and/or damage to the environment. All necessary measures must be taken to ensure over pressurization does not occur.

---

 **WARNING**

---

Operation of any pumping system with a blocked suction and discharge must be avoided in all cases. Operation, even for a brief period under these conditions, can cause superheating of enclosed pumpage and result in a violent explosion. All necessary measures must be taken by the end user to ensure this condition is avoided.

---

 **WARNING**

---

The pump may handle hazardous and/or toxic fluids. Care must be taken to identify the contents of the pump and eliminate the possibility of exposure, particularly if hazardous and/or toxic. Potential hazards include, but are not limited to, high temperature, flammable, acidic, caustic, explosive, and other risks.

---

 **WARNING**

---

Pumping equipment Instruction, Operation, and Maintenance manuals clearly identify accepted methods for disassembling pumping units. These methods must be adhered to. Specifically, applying heat to impellers and/or impeller retaining devices to aid in their removal is strictly forbidden. Trapped liquid can rapidly expand and result in a violent explosion and injury.

ITT Goulds Pumps will not accept responsibility for physical injury, damage, or delays caused by a failure to observe the instructions for installation, operation, and maintenance contained in this Pump Safety Manual or the current IOM available at [www.gouldspumps.com/literature](http://www.gouldspumps.com/literature).

# SAFETY

## DEFINITIONS

Throughout this manual the words **WARNING**, **CAUTION**, **ELECTRICAL**, and **ATEX** are used to indicate where special operator attention is required.

**Observe all Cautions and Warnings highlighted in this Pump Safety Manual and the IOM provided with your equipment.**



### **WARNING**

Indicates a hazardous situation which, if not avoided, could result in death or serious injury.

**Example:** Pump shall never be operated without coupling guard installed correctly.



### **CAUTION**

Indicates a hazardous situation which, if not avoided, could result in minor or moderate injury.

**Example:** Throttling flow from the suction side may cause cavitation and pump damage.



### **ELECTRICAL HAZARD**

Indicates the possibility of electrical risks if directions are not followed.

**Example:** Lock out driver power to prevent electric shock, accidental start-up, and physical injury.









When installed in potentially explosive atmospheres, the instructions that follow the Ex symbol must be followed. Personal injury and/or equipment damage may occur if these instructions are not followed. If there is any question regarding these requirements or if the equipment is to be modified, please contact an ITT Goulds Pumps representative before proceeding.













**Example:**  Improper impeller adjustment could cause contact between the rotating and stationary parts, resulting in a spark and heat generation.



## GENERAL PRECAUTIONS

### WARNING

A pump is a pressure vessel with rotating parts that can be hazardous. Hazardous fluids may be contained by the pump including high temperature, flammable, acidic, caustic, explosive, and other risks. Operators and maintenance personnel must realize this and follow safety measures. Personal injuries will result if procedures outlined in this manual are not followed. ITT Goulds Pumps will not accept responsibility for physical injury, damage or delays caused by a failure to observe the instructions in this manual and the IOM provided with your equipment.

General Precautions		
WARNING		NEVER APPLY HEAT TO REMOVE IMPELLER. It may explode due to trapped liquid.
WARNING		NEVER use heat to disassemble pump due to risk of explosion from tapped liquid.
WARNING		NEVER operate pump without coupling guard correctly installed.
WARNING		NEVER run pump below recommended minimum flow when dry, or without prime.
WARNING		ALWAYS lock out power to the driver before performing pump maintenance.
WARNING		NEVER operate pump without safety devices installed.
WARNING		NEVER operate pump with discharge valve closed.
WARNING		NEVER operate pump with suction valve closed.
WARNING		DO NOT change service application without approval of an authorized ITT Goulds Pumps representative.
WARNING		<p><b>Safety Apparel:</b></p> <ul style="list-style-type: none"> <li>♦ Insulated work gloves when handling hot bearings or using bearing heater</li> <li>♦ Heavy work gloves when handling parts with sharp edges, especially impellers</li> <li>♦ Safety glasses (with side shields) for eye protection</li> <li>♦ Steel-toed shoes for foot protection when handling parts, heavy tools, etc.</li> <li>♦ Other personal protective equipment to protect against hazardous/toxic fluids</li> </ul>
WARNING		<p><b>Receiving:</b></p> <p>Assembled pumping units and their components are heavy. Failure to properly lift and support equipment can result in serious physical injury and/or equipment damage. Lift equipment only at specifically identified lifting points or as instructed in the current IOM. Current manuals are available at <a href="http://www.gouldspumps.com/literature_ioms.html">www.gouldspumps.com/literature_ioms.html</a> or from your local ITT Goulds Pumps sales representative. Note: Lifting devices (eyebolts, slings, spreaders, etc.) must be rated, selected, and used for the entire load being lifted.</p>
WARNING		<p><b>Alignment:</b></p> <p>Shaft alignment procedures must be followed to prevent catastrophic failure of drive components or unintended contact of rotating parts. Follow coupling manufacturer's coupling installation and operation procedures.</p>

<b>General Precautions</b>		
<b>WARNING</b>		Before beginning any alignment procedure, make sure driver power is locked out. Failure to lock out driver power will result in serious physical injury.
<b>CAUTION</b>		<b>Piping:</b> Never draw piping into place by forcing at the flanged connections of the pump. This may impose dangerous strains on the unit and cause misalignment between pump and driver. Pipe strain will adversely effect the operation of the pump resulting in physical injury and damage to the equipment.
<b>WARNING</b>		<b>Flanged Connections:</b> Use only fasteners of the proper size and material.
<b>WARNING</b>		Replace all corroded fasteners.
<b>WARNING</b>		Ensure all fasteners are properly tightened and there are no missing fasteners.
<b>WARNING</b>		<b>Startup and Operation:</b> When installing in a potentially explosive environment, please ensure that the motor is properly certified.
<b>WARNING</b>		Operating pump in reverse rotation may result in contact of metal parts, heat generation, and breach of containment.
<b>WARNING</b>		Lock out driver power to prevent accidental start-up and physical injury.
<b>WARNING</b>		The impeller clearance setting procedure must be followed. Improperly setting the clearance or not following any of the proper procedures can result in sparks, unexpected heat generation and equipment damage.
<b>WARNING</b>		If using a cartridge mechanical seal, the centering clips must be installed and set screws loosened prior to setting impeller clearance. Failure to do so could result in sparks, heat generation, and mechanical seal damage.
<b>WARNING</b>		The coupling used in an ATEX classified environment must be properly certified and must be constructed from a non-sparking material.
<b>WARNING</b>		Never operate a pump without coupling guard properly installed. Personal injury will occur if pump is run without coupling guard.
<b>WARNING</b>		Make sure to properly lubricate the bearings. Failure to do so may result in excess heat generation, sparks, and / or premature failure.
<b>CAUTION</b>		The mechanical seal used in an ATEX classified environment must be properly certified. Prior to start up, ensure all points of potential leakage of process fluid to the work environment are closed.
<b>CAUTION</b>		Never operate the pump without liquid supplied to mechanical seal. Running a mechanical seal dry, even for a few seconds, can cause seal damage and must be avoided. Physical injury can occur if mechanical seal fails.
<b>WARNING</b>		Never attempt to replace packing until the driver is properly locked out and the coupling spacer is removed.
<b>WARNING</b>		Dynamic seals are not allowed in an ATEX classified environment.
<b>WARNING</b>		DO NOT operate pump below minimum rated flows or with suction and/or discharge valve closed. These conditions may create an explosive hazard due to vaporization of pumpage and can quickly lead to pump failure and physical injury.

General Precautions		
WARNING		Ensure pump is isolated from system and pressure is relieved before disassembling pump, removing plugs, opening vent or drain valves, or disconnecting piping.
WARNING		<b>Shutdown, Disassembly, and Reassembly:</b> Pump components can be heavy. Proper methods of lifting must be employed to avoid physical injury and/or equipment damage. Steel toed shoes must be worn at all times.
WARNING		The pump may handle hazardous and/or toxic fluids. Observe proper decontamination procedures. Proper personal protective equipment should be worn. Precautions must be taken to prevent physical injury. Pumpage must be handled and disposed of in conformance with applicable environmental regulations.
WARNING		Operator must be aware of pumpage and safety precautions to prevent physical injury.
WARNING		Lock out driver power to prevent accidental startup and physical injury.
CAUTION		Allow all system and pump components to cool before handling them to prevent physical injury.
CAUTION		If pump is a Model NM3171, NM3196, 3198, 3298, V3298, SP3298, 4150, 4550, or 3107, there may be a risk of static electric discharge from plastic parts that are not properly grounded. If pumped fluid is non-conductive, pump should be drained and flushed with a conductive fluid under conditions that will not allow for a spark to be released to the atmosphere.
WARNING		Never apply heat to remove an impeller. The use of heat may cause an explosion due to trapped fluid, resulting in severe physical injury and property damage.
CAUTION		Wear heavy work gloves when handling impellers as sharp edges may cause physical injury.
CAUTION		Wear insulated gloves when using a bearing heater. Bearings will get hot and can cause physical injury.

## ATEX CONSIDERATIONS and INTENDED USE

Special care must be taken in potentially explosive environments to ensure that the equipment is properly maintained. This includes but is not limited to:

1. Monitoring the pump frame and liquid end temperature.
2. Maintaining proper bearing lubrication.
3. Ensuring that the pump is operated in the intended hydraulic range.

The ATEX conformance is only applicable when the pump unit is operated within its intended use. Operating, installing or maintaining the pump unit in any way that is not covered in the Instruction, Operation, and Maintenance manual (IOM) can cause serious personal injury or damage to the equipment. This includes any modification to the equipment or use of parts not provided by ITT Goulds Pumps. If there is any question regarding the intended use of the equipment, please contact an ITT Goulds representative before proceeding. Current IOMs are available at [www.gouldspumps.com/literature\\_ioms.html](http://www.gouldspumps.com/literature_ioms.html) or from your local ITT Goulds Pumps Sales representative.

All pumping unit (pump, seal, coupling, motor and pump accessories) certified for use in an ATEX classified environment, are identified by an ATEX tag secured to the pump or the baseplate on which it is mounted. A typical tag would look like this:



The CE and the Ex designate the ATEX compliance. The code directly below these symbols reads as follows:

- II = Group 2
- 2 = Category 2
- G/D = Gas and Dust present
- T4 = Temperature class, can be T1 to T6 (see Table 1)

<b>Code</b>	<b>Max permissible surface temperature °F (°C)</b>	<b>Max permissible liquid temperature °F (°C)</b>
T1	842 (450)	700 (372)
T2	572 (300)	530 (277)
T3	392 (200)	350 (177)
T4	275 (135)	235 (113)
T5	212 (100)	Option not available
T6	185 (85)	Option not available

The code classification marked on the equipment must be in accordance with the specified area where the equipment will be installed. If it is not, do not operate the equipment and contact your ITT Goulds Pumps sales representative before proceeding.

## PARTS

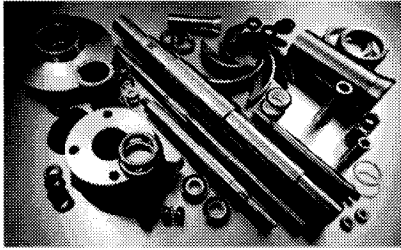

The use of genuine Goulds parts will provide the safest and most reliable operation of your pump. ITT Goulds Pumps ISO certification and quality control procedures ensure the parts are manufactured to the highest quality and safety levels.

Please contact your local Goulds representative for details on genuine Goulds parts.

---

## TABLE OF CONTENTS

SECTION	I - GENERAL
	I-A Importance of Instructions
	I-B Special Warnings
	I-C Receiving Inspection - Shortages
	I-D Preservation and Storage
	I-E Handling Techniques
SECTION	II - INSTALLATION
	II-A Location
	II-B Pump Support
	II-C Rotation Check
	II-D Alignment Procedures
	II-E Piping Recommendations
SECTION	III - PREPARATION FOR OPERATION
	III-A Stuffing Box Preparation
	III-B Seal Chamber Cooling
	III-C Lubrication
	III-D Gauges
	III-E Free Turning
	III-F Valve Line-up
	III-G Priming
SECTION	IV - OPERATION
	IV-A Start-Up Precautions
	IV-B Operational Checks
	IV-C Shutdown Procedures
	IV-D Doweling Motor to Motor Support
SECTION	V - PREVENTATIVE MAINTENANCE
	V-A Lubrication
	V-B Repacking Stuffing Boxes
	V-C Alignment Recommendations
	V-D Vibration
	V-E Overhaul Recommendations
SECTION	VI - CORRECTIVE MAINTENANCE
	VI-A Disassembly of Pump
	VI-B Inspection of Parts
	VI-C Reassembly of Pump
	VI-D Torque Chart
SECTION	VII - PRODUCT DESCRIPTION
	VII-A Sectional View with Parts List and Construction Details
	VII-B Mechanical Seal Options
	VII-C Cooling Water Piping Plans
SECTION	VIII - TROUBLE SHOOTING
SECTION	IX - SPARE PARTS

## INTRODUCTION

This instruction manual is intended to assist those involved with the installation, operation and maintenance of Goulds Model 3900 and 3901 pumps. The Model 3900-3901 has been designed for maximum structural strength and rigidity, while at the same time allowing for maximum accessibility and ease of maintenance in the mechanical seal and stuffing box areas. It is recommended that this manual be thoroughly reviewed prior to installing or performing any work on the pump or motor.

### SECTION I -- GENERAL

#### I-A Importance of Instructions

The design, material and workmanship incorporated in the construction of Goulds pumps makes them capable of giving long, trouble-free service. The life and satisfactory service of any mechanical unit, however are enhanced and extended by correct application, proper installation, periodic inspection and careful maintenance. This instruction manual was prepared to assist operators in understanding the construction and correct methods of installing, operating and maintaining these pumps.

Study thoroughly Sections I, II, III and IV and carefully follow the instructions for installation and operation. Section V, VI, VII and VIII are answers to trouble and maintenance questions. Keep this instruction manual handy for reference. Further information can be obtained by contacting the Engineered Products Division, Goulds Pumps, Inc., Seneca Falls, New York 13148 or your local Goulds branch office.

I-B Special Warnings

Goulds Pumps, Inc. will not be liable for any damages or delay caused by failure to comply with the provisions of this instruction manual.

CAUTION - OPERATION OF THIS EQUIPMENT WITHOUT A SUITABLE COUPLING GUARD IS A VIOLATION OF THE OCCUPATIONAL SAFETY AND HEALTH ADMINISTRATION GUIDELINES.

This pump is not to be operated at speeds, working pressures, discharge pressures or temperatures higher than, nor used with liquids other than stated in the original order acknowledgement without written permission from Goulds Pumps, Inc.

I-C RECEIVING INSPECTION--SHORTAGES

Care should be taken when unloading pumps. If shipment is not delivered in good order and in accordance with the Bill of Lading, note the damage or shortage on both receipt and freight bill. MAKE ANY CLAIMS TO THE TRANSPORTATION COMPANY PROMPTLY.

Instruction sheets on various components, as well as the Instruction Book for the pump, are included in the shipment. DO NOT DISCARD!!

#### I-D. PRESERVATION AND STORAGE

Goulds' normal domestic storage preparation is suitable for protecting the pump during shipment in covered trucks. It also provides protection during covered storage at the jobsite and for a short period between installation and start-up. If the pump is to be idle and exposed to the elements for an extended period, either before or after installation, special precautions are required. One approach is to provide special preservatives and wrappings before shipment. However, after installation, the protective wrappings will have been removed. Therefore, application of preservatives after installation is considered a good practice. Information about various long term preservation and storage options available can be obtained from your local Goulds' representative.

The driver, coupling, and mechanical seal manufacturers should be contacted for their recommendations on preservation and protective procedures.

#### I-E. Handling Techniques

Care should be used in moving pumps. An assembled Model 3900 should be hoisted using a sling thru the motor support. Care should be taken to prevent the motor from turning over when the unit is supported by the sling.

## SECTION II -- INSTALLATION

### II-A Location

Pumping unit should be placed as close as practical to the source of supply. Floor space and head room allotted to the unit must be sufficient for inspection and maintenance. Be sure to allow for crane or hoist service.

### II-B Pump Support

Model 3900 in-line pumps are designed to be mounted directly in, and supported by the piping. No supports under the pump are required. Pipe supports should be located close to the pump, and be designed to support the weight of the complete unit (pump and motor). The pump maybe supported by adding a pad under the pump to support the weight of the unit and assure undue stress is not applied to the pipe flanges.

### II-C Rotation

To prevent seizure of parts with close running clearances in new or recently opened pipe system, it is not advisable to check rotation of driver while coupled to pump.

Before coupling is connected, verify rotation of driver. The direction of

rotation is marked on the motor support. Make sure driver rotates in the same direction.

## II-D Alignment Procedures

### Pumps Shipped Complete

Alignment of pump and driver is of extreme importance for trouble free mechanical operation.

The factory installed motor has been factory aligned and doweled. This alignment may be disturbed during handling and shipment. If pump doesn't rotate freely or vibration levels exceed API 610 the alignment must be checked in the following manner.

The parallel alignment is accomplished by moving the motor around until both axis of its shaft are centered to the pump backplate within .002" (.051 mm)TIR. Angular alignment is adjusted by placing shims between motor base and motor support (240) to obtain a .002" TIR max.

The following steps should be followed to establish proper alignment  
between pump and driver.

MAKE SURE THAT THE MOTOR CONTROLS ARE "LOCKED OUT TO PREVENT ACCIDENTAL ROTATION.

FIGURES 1 & 2

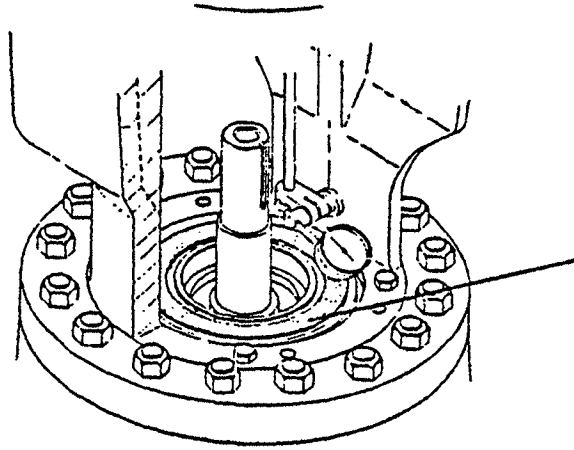

Surface for angular  
alignment

Fig.#1

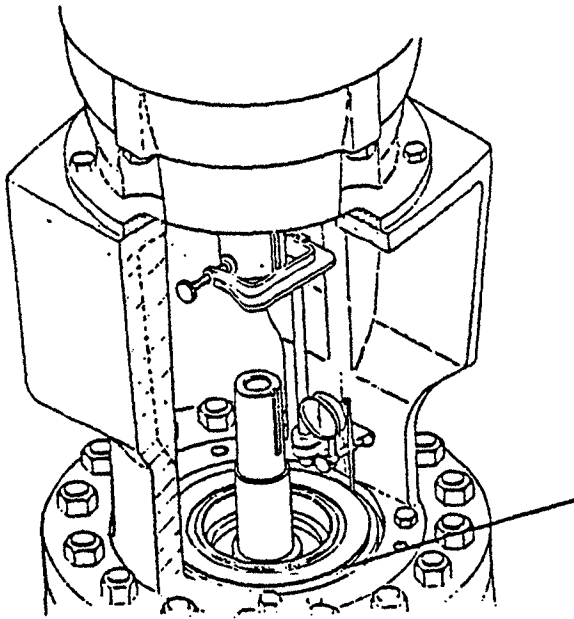

Surface for horizontal  
alignment

Fig.#2

1. Remove coupling guard
2. Remove piping connected to seal chamber
3. Remove rigid coupling assembly (232)
4. Loosen seal chamber hold down nuts (355)
5. Remove shaft retaining ring (216)
6. Rotate seal chamber (159) clockwise to "disengage position"  
this allows removal of seal chamber without pulling bushing  
(197A) and bushing holder (467).
7. Remove seal chamber (157) using jack bolts (418)
8. Remove rotating portion of mechanical seal - "CARE SHOULD BE  
EXERCISED SO THAT THE MECHANICAL SEAL IS NOT DAMAGED".
9. Loosen motor hold down bolts (371)
10. Mount dial indicator on driver shaft to check angular  
alignment (Fig 1). Then mount indicator to check  
horizontal runout (Fig. 2).
11. Tighten motor bolts (371) and recheck alignment
12. Redowel motor to motor support
13. Reassemble pump

Pumps Shipped Less Motor

Alignment Procedures

1. Check driver shaft runout. It is important to check shaft runout on all drivers. Distortion during shipment can occur whether driver is mounted or not. In case of an apparent out of tolerance driver, consult Goulds representative or the driver manufacture.

The maximum face runout .004" TIR.

The maximum shaft runout .001" TIR on LP motors

FIGURES #3 & 4

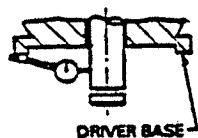

Fig. #3

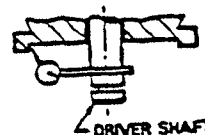

Fig. #4

2. When driver shaft runout has been checked, lift driver on to motor support. Install bolts fingertight.

3. Follow alignment procedure under pump/motor alignment.

## II-E Piping Recommendations

### 1. Piping - General

a. All piping must be supported independently of the pump. The piping should always "line-up" naturally with the pump flanges. NEVER DRAW THE PIPING INTO PLACE BY USE OF FORCE AT THE FLANGED SUCTION AND DISCHARGE CONNECTIONS OF THE PUMP AS THIS MAY IMPOSE DANGEROUS STRAINS ON THE UNIT AND CAUSE LOSS OF INITIAL ALIGNMENT.

b. The piping, both suction and discharge, should be as short and direct as possible. Avoid all unnecessary elbows, bends and fittings, as they increase the friction losses in the piping. The size of pipe and fittings should be carefully selected and of sufficient size to keep the friction losses as low as practical.

c. When handling liquids at elevated temperatures, the forces and moments due to thermal expansion of the piping system that can act on the pump nozzles must be determined and not allowed to exceed the limits as stated in the API 610, Sixth Edition. Use of properly supported and aligned expansion loops or expansion joints are recommended for high temperature services as they will minimize the effects of linear expansion of the piping system to pump nozzles.

d. Expansion joints, when used, should not be intended to make up for misaligned piping and should be of the restrained type only. Use of unrestrained expansion joints or poorly supported expansion loops result in excessive forces on the pump nozzles.

## 2. Piping - Suction

Properly designed suction piping is of extreme importance for trouble-free centrifugal pump operation.

- a. The suction pipe should never be of a smaller diameter than the pump suction nozzle. Use of suction pipe one or two sizes larger than the suction nozzle with a reducer, is desirable. Reducers when used should be of the eccentric type installed directly on the suction nozzle with the sloping side down.
- b. A suction screen should be installed prior to initial start-up and when suction system has been opened for work. The net area equal to at least 3 times the cross sectional area of the suction pipe. The mesh of the screen should be sized to prevent particles larger than 1/16" from entering the pump and installed in a spool piece to allow removal for cleaning (Fig. 5). The screen should remain in the system until periodic inspection shows system is clean.

c. Installation with Pump Above Source of Supply - Suction Lift

1. Keep suction pipe free from air pockets.
2. Piping should slope upwards from source of supply.
3. No portion of piping should extend above the pump suction nozzle.
4. All joints MUST be air tight.

d. Installations with Pump Below Source of Supply - Suction Head or Flooded Suction

1. A gate valve should be installed in the suction line to permit closing of the line for pump inspection and maintenance.
2. Keep suction pipe free from air pockets.
3. Piping should be level or slope gradually downward from the source of supply.
4. The size of entrance from supply should be no smaller than the suction nozzle.

5. The suction pipe should be adequately submerged below the liquid surface at the source of supply.

### 3. PIPING - Discharge

a. Isolation and check valves should be installed in the discharge line. The check valve should be located between the isolation valve and pump to permit inspection of the check valve. The check valve is required to prevent reverse flow through the pump when the driver is turned off.

b. Increasesers, if used in discharge line, should be placed between the pump and check valves. If quick-closing valves are installed in the system, cushioning devices should be used to protect the pump from surges and water hammer. Additional piping information can be found in the "Hydraulic Institute Standards".

### 4. PIPING - AUXILIARY

Auxiliary piping may be required for seal chamber cooling, mechanical seal flush, lantern ring flush or other special features supplied with the pump. Consult pump data sheet for specific auxiliary piping recommendations.

### 5. BYPASS PIPING

Systems that require operation at reduced flows for prolonged periods should be provided with a bypass line connected from the discharge side

(before any valves) to the source of suction. A minimum flow orifice can be sized and installed in bypass line to preclude by-passing excessive flows. Consult nearest sales office or factory for assistance in sizing orifice.

## SECTION III -- PREPARATION FOR OPERATION

### III-A Stuffing Box Preparation

#### 1. PACKING

##### a. Remove Coupling

b. Stuffing box packing and gland are in the box of fittings supplied with the pump.

c. Inspect and thoroughly clean the stuffing box bore. Install three rings of packing in bottom of stuffing box (four rings on the XL frame.) Reinstall the lantern ring into the stuffing box against the third ring. Install the outboard three rings of packing. If the last ring of packing does not completely enter the bore of the stuffing box, do not force. Leave the last ring of packing out until packing adjustments made during operation will permit it to enter.

d. When installing packing rings, twist the rings sideways instead of straight out when putting them on the shaft (FIG. 6). Bending them

straight out will cause some forms of packing to break. Set each ring firmly as it is installed and stagger the joints at least 90 degrees.

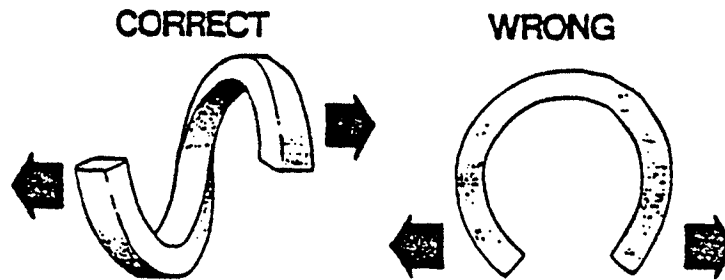

FIG. 6

d. With the packing and lantern ring installed, position one half of the two-piece packing gland on the shaft. Insure that non-sparking bushing enters machined groove at outboard end of gland half. Positoin the other half of the packing gland over the first and fasten the gland half together with the packing gland clamp screws (FIG. 7).

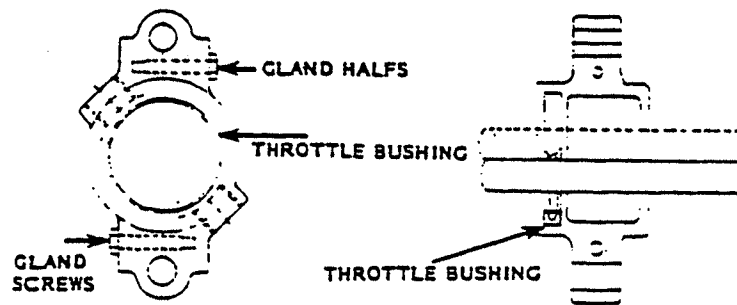

FIG. 7.

e. Install packing gland adjusting nuts. Tighten the gland nuts evenly until the packing gland enters the stuffing box approximately 1/16". Relax adjusting nust and set finger tight.

## 2. LANTERN RING FLUSH

Lantern ring flush is required when the pumpage is dirty or corrosive and occasionally when the stuffing box is below atmospheric pressure (vacuum). When required, connect a clean liquid flush to the lantern ring connection at a pressure approximately 15 PSIG greater than the pump's suction pressure.

## 3. MECHANICAL SEALS

When mechanical seals are supplied on the pump, they are installed and set at the factory. Mechanical seals must not run dry or in abrasives. Study all applicable mechanical seal literature and drawing to determine type of seal and flushing requirements. Some mechanical seal options are shown in Section VII-B and Section VII-C outlines flush/cooling plan variations.

NOTE: Sections VII-B and VII-C are general in nature and are to be used as a guide only.

### III-B SEAL CHAMBER COOLING

The Model 3900 can be supplied with seal chamber cooling provisions, depending on pumpage temperature, and/or customer preference.

Cooling water should be piped to the cooling chamber jacket with isolation valves at inlet and outlet.

Cooling water pressure to the seal chamber cooling jacket should not exceed 75 PSIG. Flows of 1 GPM will generally satisfy all cooling requirements.

See Section VII-B for various cooling water piping flows. Consult pump data sheet for individual pump requirements.

### III-C Lubrication

Drivers require periodic lubrication. Refer to the motor manufacturer's instructions and specifications for the recommended procedure.

### III-D Gauges

Install suction and discharge gauges on or as close as possible to the pump nozzles. Where a suction screen is used, an additional gauge must be installed upstream of the screen to measure pressure drop.

### III-E Check for Free Turning

Before pump is started, rotate shaft by hand to be sure it is free. Drag from packing or seal is normal, but if pump cannot be turned by hand, or binding is felt, investigation and correction of the cause is required.

### III-F Valve Line-Up

The pump discharge valve should be fully closed.

When used, open all recirculation line valves and verify recirculation flow path. The suction valve must be fully open and all air vented from casing.

Open all cooling water valves and establish flows to the mechanical seal (lantern ring connection when used) and any auxiliary equipment when supplied with the unit.

### III-G Priming

Pump and suction pipe must be full of liquid before pump is started.

Usually, suction supply will be primed when pump shutoff valves are opened.

If suction supply is below pump, priming by other means, such as foot valve or ejector, will be required.

## SECTION IV -- OPERATION

### IV-A Start-Up Precautions

1. All equipment and personnel safety related devices and controls must be installed and operating properly.

CAUTION - OPERATION OF THIS EQUIPMENT WITHOUT A SUITABLE COUPLING GUARD IS A VIOLATION OF THE OCCUPATIONAL SAFETY AND HEALTH ADMINISTRATION GUIDELINES.

2. To prevent premature pump failure at initial start-up due to dirt or debris in the pipe system, insure the pump can be run continuously at full speed and flow for 2 to 3 hours. DO NOT "JOG" a coupled pump. If motor rotation has not been checked (Section II-C), uncouple unit and check rotation.
  
3. NEVER THROTTLE A CENTRIFUGAL PUMP ON THE SUCTION SIDE. This can result in cavitation and may seriously damage the pump.
  
4. Pumpage temperatures in excess of 200F will require warm-up of pump prior to operation. Circulate a small amount of pumpage through the pump until the casing temperature is within 100F of the pumpage.

#### IV-B Operational Checks

The following are minimum operational checks for the pump only. Consult driver and auxiliary equipment manufacturer's literature for additional information.

1. Start Unit. After unit reaches rated speed, immediately but slowly open pump discharge valve. Insure pump discharge pressure does not fall off rapidly. When discharge pressure remains stable, open discharge valve fully.
  
2. Check motor bearing temperature using a pyrometer or other accurate temperature measuring device. Monitor bearing temperature frequently

during initial operation to determine if a bearing problem exists as well as to establish normal bearing operation temperatures.

3. Watch stuffing box carefully after start-up. At first sign of excessive heating, shut down and allow box to cool. Do not back off gland on hot box, for this will only result in undesirable leakage around outside of packing. Packing leak-off during initial run-in should be excessive. Do not attempt to reduce leak-off until packing has had a chance to run-in and set itself. After run-in period (usually 2 to 3 hours), leak-off can be slowly reduced to a more tolerable rate. A final leak-off of 40 to 60 drops per minute is satisfactory in most cases. Leak-off rates in excess of 40 to 60 drops may be necessary depending on the size of the packing, shaft sleeve diameter and stuffing box pressures.

4. Check for rough running. When it is determined that the unit is running rough, a vibration analysis should be made to determine the cause.

5. Monitor all gauges to insure pump is running at or near rating and that suction screen (when used) is not being clogged.

#### IV-C Shut Down Procedures

1. When the decision is made to shut down the unit, close the discharge valve and shut down or stop the driver.

2. When the unit comes to a complete stop, de-energize the power to the motor. Remove coupling guard and turn unit by hand. Should unit bind or not turn at all, an investigation must be made and the cause corrected. (Refer to Section VIII for assistance.)

#### IV-D Doweling Motor to Motor Support

The motor must be doweled to the motor support to positively maintain motor position. Two (2) number 7 taper pins are supplied for this purpose.

1. Drill two holes, one in each side of the motor. Use a  $21/64$ " or "Q" size drill. The holes should be drilled through both the motor mounting base and the motor support. This makes cleaning the metal chips produced from drilling and reaming easier.

2. Ream the holes with a number 7 taper pin reamer to the proper fit with the taper dowel pins. The pins should insert to a depth that leaves only the threaded portion exposed when fully seated.

3. The dowel pins should then be removed prior to motor removal by tightening the  $3/8$ " hex nuts provided on the pins. If the pins are not seated deep enough in the motor support, a spacer under the hex nut may be required to lift the pins free when the hex nut is tightened.

CAUTION: Failure to remove the dowel pins prior to motor removal may result in damage.

## SECTION V -- PREVENTATIVE MAINTENANCE

### V-A LUBRICATION

1. Refer to motor manufacturer's recommendation for the lubrication of driver.
2. All bearings operate at some temperature above that of the surrounding atmosphere, unless cooled. Heat is generated within the bearing due to rolling friction, and the drag of the cage. Do not use the human hand as a thermometer.

A temperature which feels "hot" varies from 100F to 130F depending on the individual. Above this temperature, the human hand is useless in estimating temperature. Determine the temperature accurately by placing a contact type thermometer against the motor bearing housing. Refer to motor manufacturer's recommendation for temperature limits. A stable temperature is an indication of normal operation. A sudden increase in temperature is an indication of danger and a signal to investigate. The unit should also be checked for unstable hydraulic operation and unnecessary loads, such as coupling misalignment.

V-B REPACKING STUFFING BOXES

1. Stuffing box packing should be replaced when packing gland adjustment can no longer control the stuffing box leak-off.
  
2. To remove the stuffing box gland assembly, uncouple pumps and unscrew and remove gland adjusting nuts. Slide gland out of the stuffing box over the end of the shaft. This now affords unobstructed access to the stuffing box for repacking.
  
3. Remove the first group of packing rings (3 each) with the aid of a packing hook.
  
4. Remove the lantern ring by inserting wire hooks into the slots on the outer edge of the ring and pulling the ring from the box.
  
5. Remove second group of packing rings again using a packing hook. XL size pumps have four (4) rings of packing behind the lantern ring. All other sizes have three (3).
  
6. Remove all foreign matter from the stuffing box bore.
  
7. Install new stuffing box packing as described in Section III-A.

### V-C ALIGNMENT

A complete alignment check between driver and pump is required if the pump has been disassembled for any reason. Misalignment will cause excessive equipment problems such as frequent bearing, mechanical seal or packing maintenance. See Section II for alignment procedures.

### V-D VIBRATION

A periodic check of vibration is a good preventive maintenance practice. Sudden changes in vibration levels are indicative that a problem is developing and should be analyzed to assist in determining what corrective action is needed. Major causes of sudden vibration changes include misalignment, bad bearings, worn stuffing box throat bushing, impeller imbalance and vibration caused by other operating machinery.

### V-E OVERHAUL

The pump should be opened and inspected on a periodic basis. This can be scheduled yearly or when indications of a problem appear such as loss of performance and excessive vibration. Inspect parts for corrosion, erosion, excessive clearances or other physical damage that would affect the pumps mechanical or hydraulic performance.

SECTION VI -- CORRECTIVE MAINTENANCE

VI-A MECH SEAL AND BUSHING REPLACEMENT

VI-B DISASSEMBLY OF PUMP

1. De-energize power supply to motor so driver cannot be started.
2. Remove any auxiliary piping and/or equipment that will interfere with removal of seal chamber. (159)
3. Remove coupling guard.
4. On the "S" and "M" pumps loosen the coupling bolts (236) and remove coupling (232). Shaft and impeller will drop to the bottom of the casing.
5. On "L" and "XL" pumps loosen coupling bolts (236). Use lifting/lowering device on coupling (232) to lower the shaft/impeller to the bottom of the casing.
6. Remove coupling.
7. Remove shaft thrust plate (216). Bolt has right hand thread.
8. Remove motor dowel pins. Refer to Section IV-D-3
9. Remove motor.
10. On packed box pumps remove gland.
11. On units with mechanical seals loosen seal chamber nuts (355) and rotate seal chamber (159) clockwise to the disengaged position. Remove nuts (353).
12. Use of jacking bolts (418) maybe required to remove the seal chamber.

USE CAUTION REMOVING SEAL CHAMBER NOT TO DAMAGE THE MECHANICAL SEAL.

13. Remove mechanical seal rotary element.
14. Sling motor support.
15. Loosen backplate nuts (425) and tighten jacking bolts ( ).
16. Remove back pullout assembly from the pump casing.  
SHAFT AND IMPELLER MAY DROP OUT OF ASSEMBLY.
17. Take unit to the shop for complete disassembly.
18. Remove motor support by removing motor support to backplate bolts (372J).
19. Use jacking bolts to remove motor support from backplate.
20. On packed box units loosen packed box chamber nuts and rotate the chamber clockwise to the disengaged position.
21. Remove box chamber nuts (355).
22. Using jacking bolts remove packed box chamber.
23. Remove stuffing bushing (197A) and bushing holder by using seal chamber. Rotate seal chamber (159) to engaged position and using jacking bolts (418) extract the bushing holder and bushing from the backplate.

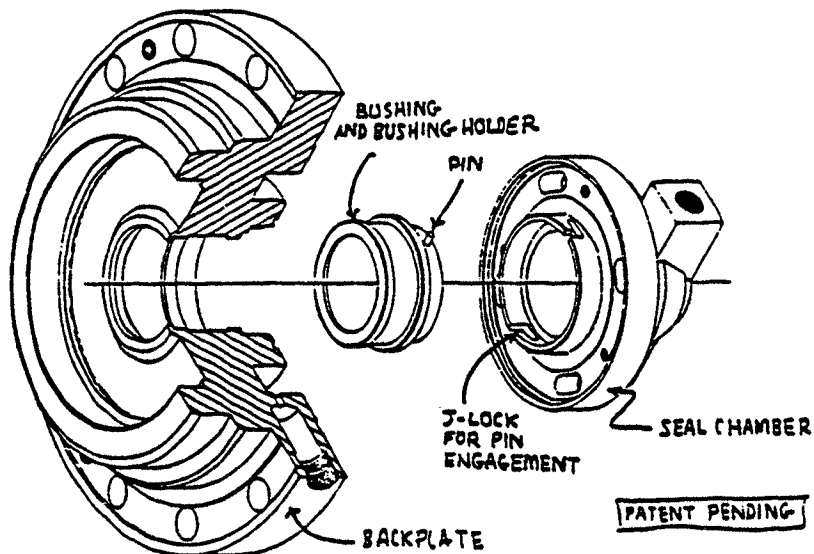
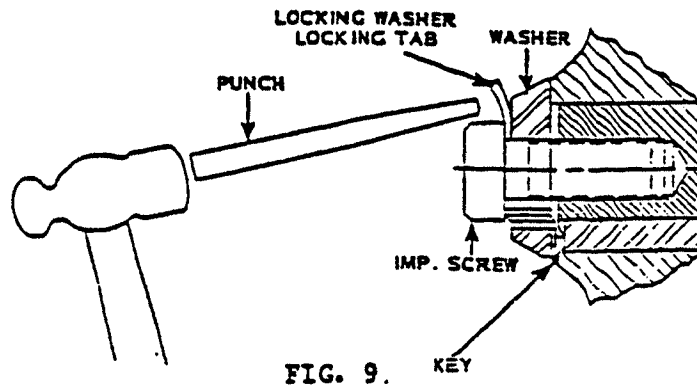

Fig.#8

24. Impeller removal - Upset impeller screws (Fig #9), loosen and remove impeller screw (198). Impeller screw has LEFT HAND THREADS. Remove impeller screw lock washer (199A) and washer (199).



#### VI-B INSPECTION OF PARTS

1. Impeller (101) -- Replace if impeller shows excessive erosion, corrosion or extreme wear. Clean and check impeller bore inside diameter and shaft fit outside diameter. Fit must be from .000" (.00mm) to .001" (.025mm) loose. Replace impeller if clearance is greater. Check impeller balance.

2. Shaft (122) -- Check shaft run out to see that shaft has not been bent. Do not use shaft centers for run out check as they may have been damaged when removing impeller. Use "V" blocks or balance rollers to support the shaft. Replace or straighten shaft if run out exceeds .001" (.025mm).

Check shaft bushing area for condition. Replace shaft if bushing area is ruined and beyond reasonable repair.

Bushing wear limits dia - 2.203"

3. Mechanical Seal -- Seal faces and shaft sealing numbers must be in perfect condition. Replace worn or damaged parts. Protect the lapped faces while working with mechanical seal.

4. Seal Chamber (159) -- All gasket seats must be in perfect condition. Renew mechanical seal throttle bushing (if supplied) when running clearance to shaft is excessive or when bushing is damaged. Replace seal chamber if beyond reasonable repair. Insure all cooling and flushing passages are clean and will allow optimum flows.

5. Wearing rings (202, 203, 164, 230) -- Units are equipped with impeller, casing and stuffing box wearing rings (if required). When the clearances between the rings becomes excessive, hydraulic performance decreases substantially. The minimum diametrical clearance between rings should be:

<u>Diameter of Impeller Ring (Inches)</u>	<u>Minimum Diametrical Clearance (Inches)</u>
Less than 2"	0.010"
2.000" - 2.499"	0.011"
2.500" - 2.999"	0.012"
3.000" - 3.499"	0.014"
3.500" - 4.999"	0.016"
5.000" - 5.999"	0.017"
6.000" - 6.999"	0.018"
7.000" - 7.999"	0.019"
8.000" - 8.999"	0.020"
9.000" - 9.999"	0.021"
10.000" - 10.999"	0.022"
11.000" - 11.999"	0.023"
12.000" - 12.999"	0.024"

For metric conversion, divide any of the above values by .03979.

TABLE 2

NOTE:

--- For operating temperatures above 500F (260C) and for materials with greater galling tendencies, increase clearance dimensions by .005" (0.127mm) diametrical.

--- Replacement of wearing rings is suggested when running clearance exceeds 100% of minimum clearance as shown in Table 2 or when the hydraulic performance has decreased to unacceptable levels.

6. Replacement of Wearing Rings -- Impeller and case wearing rings are held in place by a press fit and locked by three (3) set screws.

a. Removal of Wearing Rings

1. Remove set screws.
2. Use suitable pry or puller to force rings off impeller fit or out of casing fit. Rings may also be machined for removal. Use caution when machining to avoid damaging ring fits.

b. Installation of Wearing Rings

1. Clean ring seats thoroughly, insuring they are smooth and free of scratches.
2. Heat new impeller rings to 180 degrees to 200 degrees F and place on impeller ring seats. Chill new case rings using dry

ice or other suitable chilling substance and set rings into case fits. Be prepared to tap rings into place using a hardwood block or soft faced hammer.

3. Locate, drill and tap three (3) new set screw holes equally spaced between the original holes and the new ring and ring seat areas. Install set screws. Stake replacement wearing ring metal or impeller/casing metal near set screws.
4. Case ring run out (distortion) check. (All materials.) Measure bore of case rings after installation with inside micrometer or vernier caliper at three places (where set screws are located). Any distortion in excess of .003" (.07mm) should be corrected by machining prior to trimming new impeller rings.
5. All replacement impeller wearing rings, except those hard faced, are supplied .020" (0.5mm) to .030" (0.75mm) oversized. Turn impeller rings to size after mounting on impeller. Measure bore of casing ring to establish the required impeller ring diameter to provide the recommended running clearances as indicated in Table 2.
6. Spare hard faced impeller wearing rings are not supplied oversized but are supplied to pre-established proper running clearances when both impeller and case rings are renewed.

Install spare hard faced impeller and case rings as described in Section VI-B.9.b.

7. Impeller Wearing Ring Run-Out Check --

a. Install impeller key and impeller on shaft. Secure impeller firmly with impeller screw. Set up in "V" blocks.

b. Set dial indicator to read on impeller stuffing box side wearing ring (203). Turn shaft and note run out. Repeat this for the impeller case side wearing ring (202). Indicated run out on either impeller ring should not exceed .003" (.075mm). If wearing ring run out is excessive, check for distortion at allen set screw areas. Check shaft run out and all mating surfaces of shaft, shaft sleeve and impeller hub for perpendicularity. True up all surfaces found damaged and recheck shaft run out.

8. Gaskets and Gasket Seats

a. Spiral wound gaskets should not be reused regardless of their apparent condition. Replace case and mechanical seal chamber gaskets at each overhaul.

b. Case and gland gasket seats, including face of backplate, must be smooth and free of physical defects. Replace parts if gasket seats are ruined beyond reasonable repair.

9. Coupling Guard -- It is of utmost importance to insure that the coupling guard is maintained in first-class condition. Inspect guard for corrosion or other physical defects and repair. Replace guard if beyond reasonable repair.

10. General -- In addition, the following items must be inspected and repaired or replaced if inspection indicates continued use would be harmful to satisfactory and safe pump operation.

1. Impeller Screw (198)
2. Impeller Washer (199)
3. Impeller Lock Washer (199A)
4. Carbon Bushing (197A)
5. Bushing holder (467)
6. Packing Gland (107)
7. Lantern Ring (105)
8. Impeller and Coupling Keys
9. All Nuts, Bolts and Screws

#### VI-C REASSEMBLY

This procedure covers reassembly of the pump after complete disassembly. Make sure all directions in Section VI-B "Inspection of Parts" have been followed.

1. Install casing wear ring - measure bore - set screw (320) in place

2. Install impeller wear rings (202 & 203) and set screws - measure diameter.
  
3. Reinstall impeller key. Lubricate shaft and impeller key with an anti-seize compound. Reinstall impeller. Install impeller screw lock washer (199A), impeller screw washer (199) and impeller screw (198). Torque impeller screw to value shown on torque chart, Section VI-D. Set impeller screw lock washer tang against one of the impeller screw flats. (Fig 10).

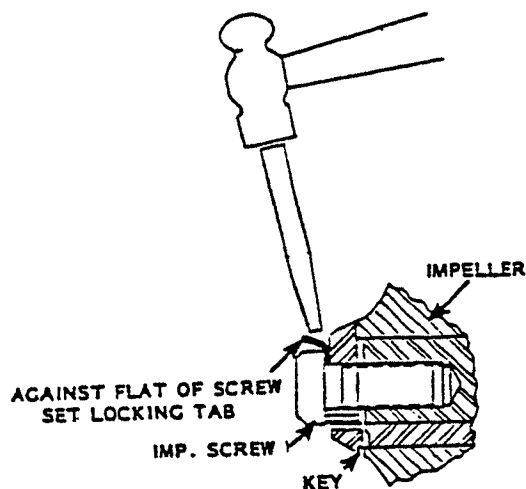

FIG. 10

4. Position impeller (101) and shaft (127) in casing.
  
5. Install wear ring (230) in backplate (444) (if required) and set screw. Measure bore.
  
6. Install new case gasket (351) in fit of casing. Lubricate casing fits with an anti-seize compound. Rig to and position the backplate (444)

to align with casing fits. Carefully guide backplate into casing. Insure case gasket (351) is not damaged.

7. Install backplate to casing (425). Inspect gap between stuffing box cover and case. Adjust case nuts (425) as necessary to square the gap. With gap square, tighten case nuts evenly using alternating pattern until stuffing box is in metal-to-metal contact with the casing. Torque each casing nut to values shown on torque chart Section VI-D. Rotating element must turn free at this time. If rubbing or binding is felt, corrective action is necessary. Refer to Section VI-B for assistance.
8. Install dowel pins (445A) in bushing holes (467). Check that dowel pins do not extend into the bore of the bushing holder. Failure to do so will result in bushing (197A) damage.
9. Press carbon bushing (197A) into bushing holder (467).
10. Apply anti-seize compound to fit between backplate and bushing holder. Install bushing holder in backplate making sure that dowel pins line up with milled slots in backplate.  
  
CARE MUST BE TAKEN TO AVOID DAMAGE TO THE CARBON BUSHING.
11. Install motor support (240) to backplate fit and torque cap screws (372J) to torque value shown in Table VI-D.

PROVISIONS MUST BE MADE TO HOLD PUMP BEFORE INSTALLING MOTOR TO PREVENT INJURY AND DAMAGE TO PUMP.

12. Rig motor and install on motor support. Install and tighten motor bolts (371) and nuts (357E) finger tight.

13. Setting shaft position

Install motor thrust ring (214). Install shaft thrust plate (216) and secure with cap screw (381). Install half of rigid coupling (232). Measure distance from top backplate to shaft shoulder. Add corresponding amount of shim to underside of shaft washer (216). Correct shaft position is achieved when top of backplate and shaft shoulder are in the same plane.

14. Remove coupling and thrust plate.

15. Install mechanical seal and set to appropriate setting dimensions (measured from shaft shoulder).

16. Seal chamber gasket.

17. Install seal chamber (159) and torque hex nuts (355) to value shown in torque table 6 D.

18. Check motor for correct rotation.

19. Install coupling. For ease of assembly install the keyed half of the coupling first and tighten socket head cap screws. Note an even gap is required between both sides of the coupling halves. Check this gap with feeler gauge to ensure it is the same along the length of the coupling.

SECTION VI-D TORQUE CHART

MAXIMUM TORQUE VALUES FOR 3900 FASTENERS (FT. - LB.)

GOULDS MATERIAL		2239	2154	2229	2228	2210
Impeller Bolt	S	173	183	49		
	M	306	324	88		
	L & XL	495	524	141		
Case Studs & Nuts	7", 9", 11"	173	183			
	13"	306	324			
	21"	1052	1112			
Seal Chamber Studs & Nuts (Mech Seal)	S & M	87	92		25	
	L & XL	173	183	49	49	
Motor Support to Backplate Cap Screws	S, M, L & XL	87	92			
Motor to Motor Support Cap Screws	S, M, L & XL					46
Coupling	S, M	35				

MATERIAL

2239 - Chrome Moly Steel  
 2154 - Monel K500  
 2229 - AISI 316  
 2228 - AISI 304  
 2210 - AISI B1112

ASTM REFERENCE

A193 B- 7 AISI 4140 Bolt Material  
 FEDQQ- N- 286 CL-A  
 A276 Type 316  
 A276 Type 304 S 30400  
 A108 GR1211

Where torque values are not shown in above chart, fasteners are not supplied in specified materials.

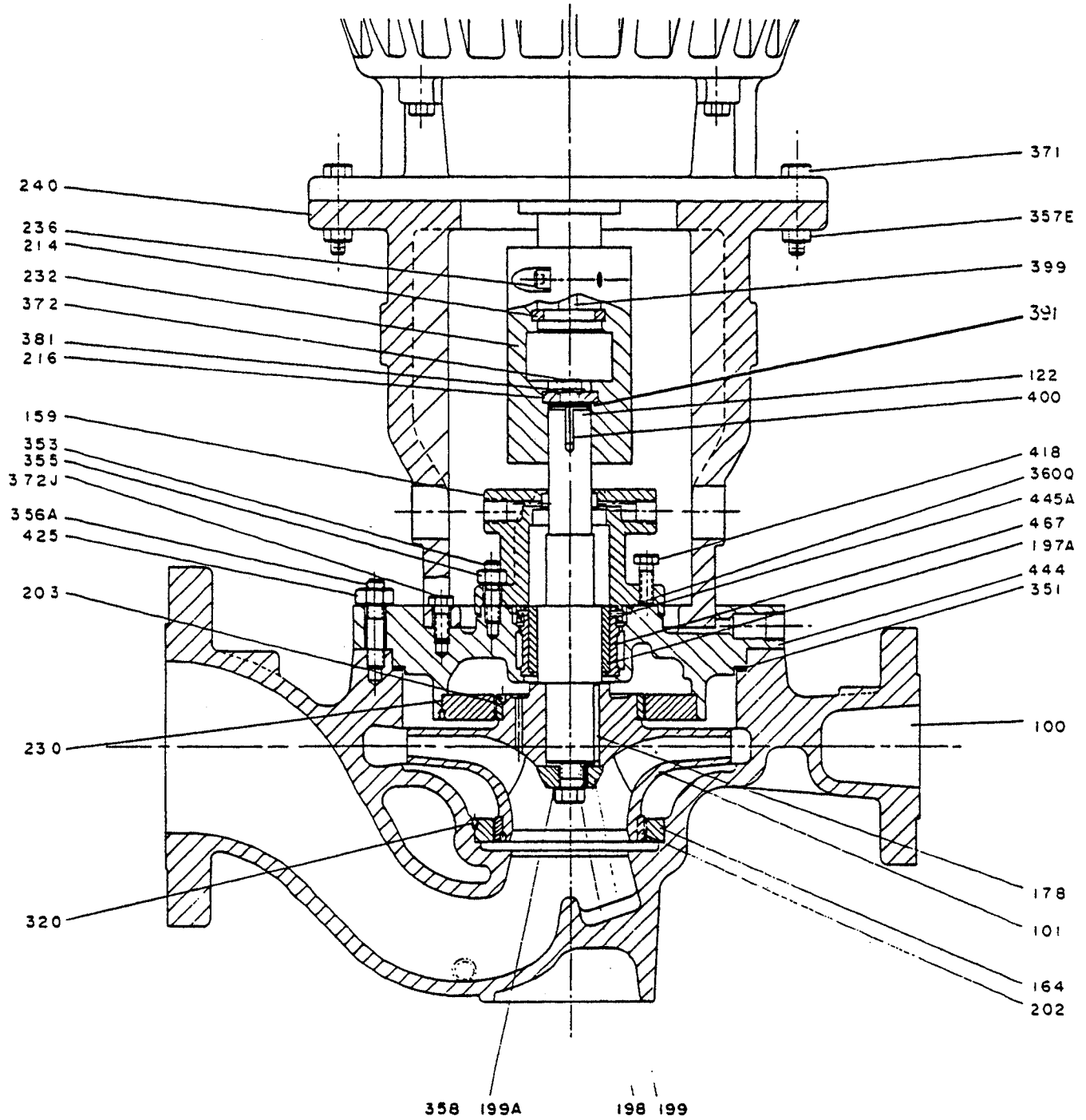
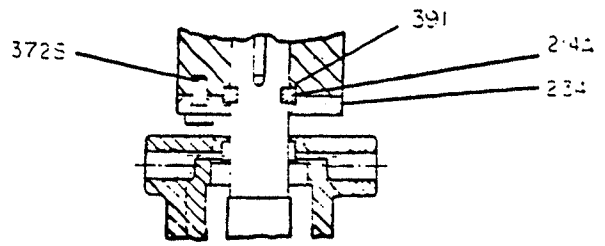

ITEM NO.	NO. REQ'D.	Part Name
100	1	Casing
101	1	Impeller
122	1	Shaft
159	1	Seal Chamber
164	1	Ring Wear Case
178	1	Key Impeller
197A	1	Bushing
198	1	Screw, Impeller
199	1	Washer, Impeller
199A	1	Lockwasher, Impeller
202	1	Ring Wrg. - Impeller (Case)
203	1	Ring Wrg. - Impeller (Bkplt)
214	1	Split Ring - Motor
216	1	Split Ring - Pump
230	1	Ring Wrg. - Backplate
232	1	Coupling - Rigid (Assy)
236	4	Soc. Hd. Screw-Cplg.
240	1	Support - Motor
320	12	Screw, Set-Wear Ring
351	1	Gasket - Case
353	4	Stud - Gland
355	4	Nut, Hex-Gland Stud
356A	Δ	Stud-Stuff. Box-Case
357E	4	Nut, Hex-Support-Mtr.
358	1	Plug - Drain
360Q	1	Gasket-Seal-Chamber
371	4	H. Tap Bolt-Support-Motor
372	1	HHM Bolt - Ring - Shaft
372J	4	H. Tap Bolt - Support-Backplate
381	1	Washer - Bolt - Shaft
399	1	Key - Coupling - Motor
400	1	Key - Coupling - Pump
418	4	H./Tap Bolt - Jacking
425	Δ	Nut, Hex - Case Stud
444	1	Backplate
445A	2	Dowel Pin - Seal Chamber
467	1	Holder - Bushing Assy.

SECTION VII-B MECHANICAL SEAL OPTIONS

# Maximum Sealing Flexibility

**Seal Types** Single, or tandem, inside or outside, balanced or unbalanced.

**Metallurgy** All alloys available.

**Glands** Plain, flush, flush vent and drain, throttle bushings — fixed or floating.

**Seat Mounting** Flexible O-ring mounted or clamped.

### Mechanical Seal API-610 Designations

**1st Letter** — Balanced or Unbalanced (B or U).

**2nd Letter** — Single or Double (S or D).

**3rd Letter** — Gland Plate (P = Plain, T = Throttle Bushing, A = Auxiliary Sealing Device).

**4th Letter** — Gasket Material.

**5th Letter** — Face Material.

#### SINGLE INSIDE BALANCED SEAL

- FLEXIBLE SEAT
- FLUSH, VENT AND DRAIN GLAND
- AUXILIARY STUFFING BOX

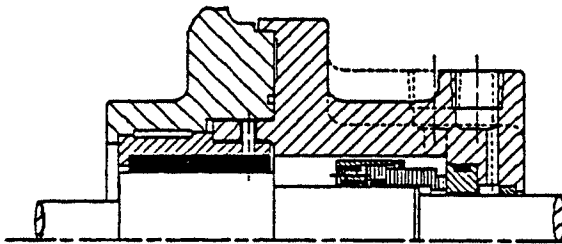

#### SINGLE INSIDE METAL BELLOWS SEAL

- VENT AND DRAIN GLAND WITH BUSHING
- STUFFING BOX FLUSH

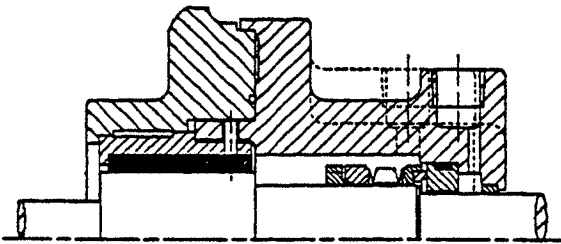

#### STATIONARY METAL BELLOWS SEAL

- FLUSH, VENT AND DRAIN GLAND

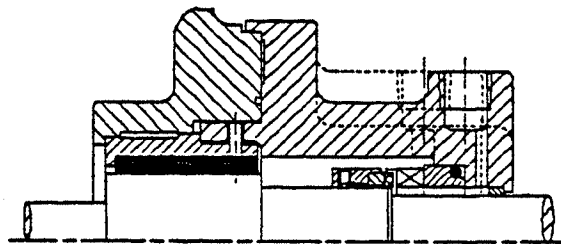

#### PUMPING RING SEAL

- FLEXIBLY MOUNTED PINNED SEAT
- PUMPING RING WITH IN-AND-OUT CIRCULATING CONNECTIONS

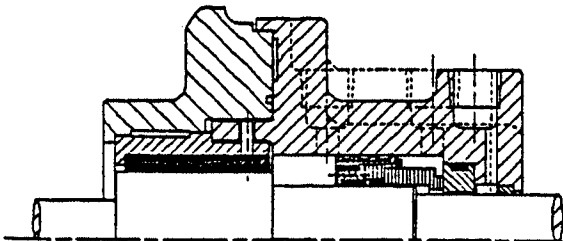

#### TANDEM SEAL

- BALANCED PRIMARY SEAL
- UNBALANCED SECONDARY SEAL
- FLUSH, VENT AND DRAIN GLAND WITH THROTTLE BUSHING

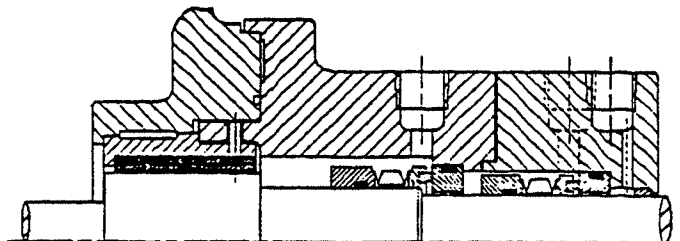

### SECTION VII-C.—COOLING WATER PIPING API-610

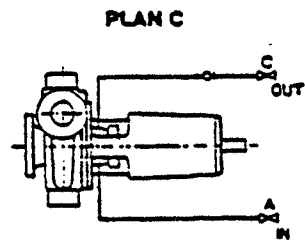

COOLING TO STUFFING BOX JACKET.

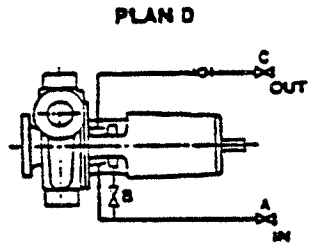

COOLING TO STUFFING BOX JACKET WITH PARALLEL FLOW TO SEAL PLATE.

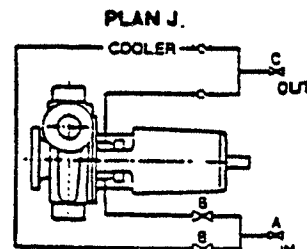

COOLING TO STUFFING BOX JACKET WITH PARALLEL FLOW TO COOLER.

**NOTES.**

- ⊗ VALVE
- ⇨ SIGHT FLOW INDICATOR WHEN SPECIFIED

VALVE 'A'—INLET SHUTOFF VALVE  
VALVE 'B'—BRANCH FLOW CONTROL VALVE

VALVE 'C'—OUTLET SHUTOFF VALVE (OPTIONAL)

SECTION VIII -- TROUBLE SHOOTING

PROBLEM	POSSIBLE CAUSES & CORRECTIONS
A No liquid delivered, not enough liquid delivered, or not enough pressure.	1, 2, 3, 4, 5, 6, 7, 8, 9, 10, 11, 12, 13, 14, 18.
B Pump works a while and then quits.	4, 5, 7, 8, 9, 11, 12, 20.
C Pump takes too much power.	6, 13, 14, 15, 16, 21, 22, 23, 24, 31.
D Pump is noisy or vibrates.	15, 16, 17, 28, 31.
E Pump leaks excessively at stuffing box.	8, 24, 25, 26, 27.
F High bearing temperature.	15, 16, 17, 29, 30, 31.
G Stuffing box overheating.	8, 24, 25, 27.

## CAUSES AND CORRECTIVE MEASURES

1. Pump not primed or properly vented -- check that casing and suction pipe are completely filled with liquid.
2. Speed too low -- check whether motor wiring is correct and receives full voltage.
3. System discharge head too high -- check system head (particularly friction losses).
4. Suction lift too high -- check NPSH available (suction piping too small or long may cause excessive friction losses). Check with vacuum or compound gage.
5. Impeller or piping obstructed -- check for obstructions.
6. Wrong direction of rotation -- check rotation.
7. Air pocket or leak in suction line -- check suction piping for air pockets and/or air leaks.
8. Stuffing box packing or seal worn allowing leakage of air into pump casing -- check packing or seal and replace as required. Check for proper lubrication.
9. Not enough suction head for hot or volatile liquids -- increase suction head, consult factory.

10. Foot valve too small -- install correct size foot valve.
11. Foot valve or suction pipe not immersed deep enough -- consult factory for proper depth. Use baffle to eliminate vortices.
12. Entrained air or gases in liquid -- consult factory.
13. Impeller wear ring clearances too great -- check for proper clearances.
14. Impeller damaged -- inspect and replace as required.
15. Excessive stuffing box throat bushing clearance -- check internal wearing parts for proper clearances.
16. Shaft bent -- straighten or replace as required.
17. Coupling or pump and driver misaligned -- check alignment and realign if required.
18. Impeller diameter too small -- consult factory for proper impeller diameter.
19. Improper pressure gauge location -- check correct position and discharge nozzle or pipe.
20. Casing gasket damaged -- check gaskets and replace as required.

21. Speed too high -- check motor winding voltage or steam pressure received by turbine.
22. Head lower than rating: pumps too much liquid -- consult factory. Install throttle valve, cut impeller.
23. Liquid heavier than anticipated -- check specific gravity and viscosity.
24. Stuffing box not properly packed (insufficient packing, not properly inserted or run-in, packing too tight) -- check packing and repack stuffing box.
25. Incorrect packing or mechanical seal -- consult factory.
26. Damaged mechanical seal -- inspect and replace as required. Consult factory.
27. Shaft scored -- remachine or replace as required.
28. Cavitation -- increase NPSH available. Consult factory.
29. Pump capacity too low -- consult factory for minimum continuous flow.
30. Excessive vibration -- See Section V-C.
31. Improper bearing lubrication or bearings worn out -- inspect and replace as required.

## SECTION IX -- SPARE PARTS

### A. INSTRUCTIONS FOR ORDERING SPARE PARTS

Repair orders will be handled with a minimum of delay if the following directions are followed:

1. Give Model No., Size of the pump and SERIAL NUMBER. These can all be obtained from the nameplate.
2. Write plainly the names, part numbers and materials of the parts required. These names and numbers should agree with those on the Sectional View in Section VI-A.
3. Give the number of parts required.
4. Give complete shipping instructions.
5. In an emergency many parts are in stock and can be shipped the same day an order is called in to the factory or your local Goulds Branch Office.
6. Contact motor rep. for motor spare parts.

## B. SPARE PARTS

To insure against possible long and costly "downtime" periods, especially on critical services, it is advisable to have spare parts on hand.

The most desirable parts to have on hand are the following:

1. Bushing, seal chamber, gasket and casing gasket.
2. Stuffing box packing (106) -- one set.
3. Stuffing box gland packing (107) -- one set.
4. Mechanical Seal (383) -- one.
5. Throat bushing and holder.
6. Wear Rings
7. Shaft

Order either 2 and 3 or 4 as required. With all other parts on hand, pump can be easily and quickly reconditioned by replacing the worn parts.

An alternative, though not as desirable as that stated above, is to have on hand parts that are most likely to wear and which can be used as needed. The following is a list of minimum spare parts that should be on hand to overhaul one pump. Quantities should be adjusted dependent on number of pumps on site and owner experience.

<u>ITEM</u>	<u>NOMENCLATURE</u>	<u>QUANTITY</u>
122	Shaft	1 ea.
	Ball Bearings Motor	1 set
360Q	Gasket Seal Chamber	1 ea.
351	Gasket Case	1 ea.
252	*Throttle Bushing - Packing Gland	1 ea.
106	*Stuffing Box Packing	1 set
203	*Impeller Wear Ring (backplate Side with Set Screws (3 ea.)	1 ea.
330	*Backplate Wear Ring with Set Screws (3 ea.)	1 ea.
202	Impeller Wear Ring (Case Side) with Set Screws (3 ea.)	1 ea.
164	Case Wear Ring with Set Screws (3 ea.)	1 ea.
199A	Impeller Lock Washer	1 ea.
	*Mechanical Seal Complete	1 ea.

\* When supplied

3900/jp/cd



**ITT**

Form I3900