

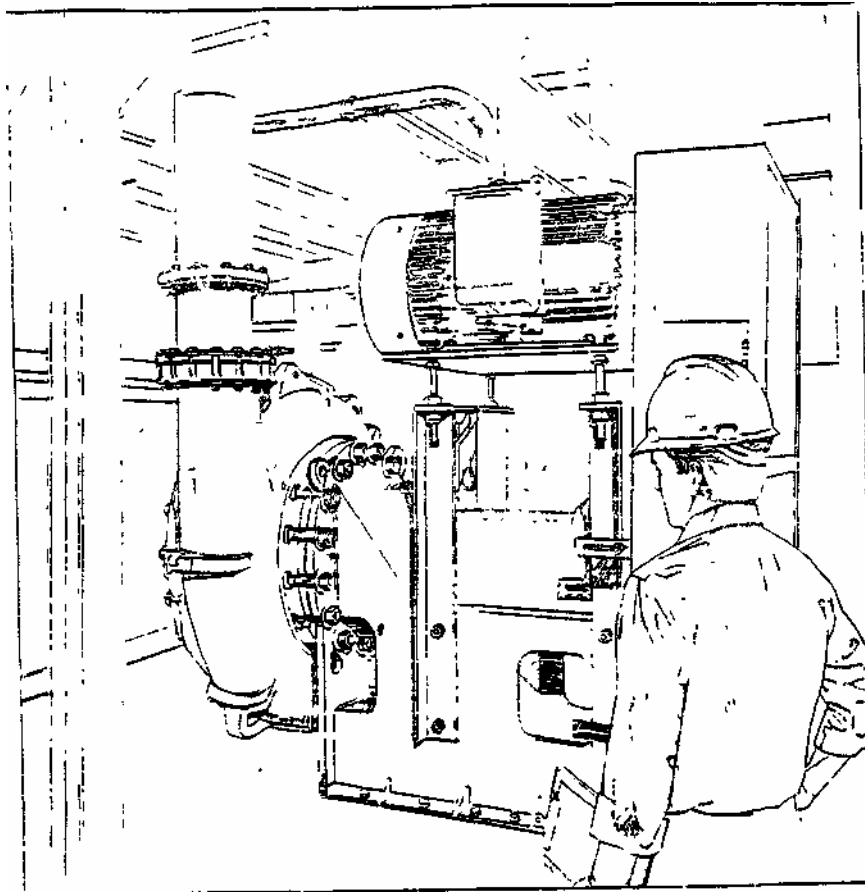

# GOULDS PUMPS, INC.

## SLURRY PUMP DIVISION

INSTALLATION, OPERATION and MAINTENANCE INSTRUCTIONS



### MODEL 5500

NAMEPLATE INFORMATION

**GOULDS PUMPS, INC.**  
SLURRY PUMP DIVISION ASHLAND, PA 17921

SERIAL NO.

MODEL

GPM  FT. HD.  IMPLR.   
DIA.

RPM  MAX. ALLOW. PRESS.   
PSI

SEE INSTRUCTION MANUAL BEFORE OPERATION  
MADE IN U.S.A.

FIG. 1.  
PUMPS NAMEPLATE INFORMATION

All 5500 pumps carry the same Goulds nameplate, shown in Fig. 1. This nameplate provides information about the pump's hydraulic characteristics.

## IMPORTANT SAFETY NOTICE

*To: Our Valued Customers*

User safety is a major focus in the design of our products. Following the precautions outlined in this manual will minimize your risk of injury.

ITT Goulds pumps will provide safe, trouble-free service when properly installed, maintained, and operated.

Safe installation, operation, and maintenance of ITT Goulds Pumps equipment are an essential end user responsibility. This *Pump Safety Manual* identifies specific safety risks that must be considered at all times during product life. Understanding and adhering to these safety warnings is mandatory to ensure personnel, property, and/or the environment will not be harmed. Adherence to these warnings alone, however, is not sufficient — it is anticipated that the end user will also comply with industry and corporate safety standards. Identifying and eliminating unsafe installation, operating and maintenance practices is the responsibility of all individuals involved in the installation, operation, and maintenance of industrial equipment.

Please take the time to review and understand the safe installation, operation, and maintenance guidelines outlined in this Pump Safety Manual and the Instruction, Operation, and Maintenance (IOM) manual. Current manuals are available at [www.gouldspumps.com/literature\\_ioms.html](http://www.gouldspumps.com/literature_ioms.html) or by contacting your nearest Goulds Pumps sales representative.

**These manuals must be read and understood before installation and start-up.**

For additional information, contact your nearest Goulds Pumps sales representative or visit our Web site at [www.gouldspumps.com](http://www.gouldspumps.com).

# SAFETY WARNINGS

Specific to pumping equipment, significant risks bear reinforcement above and beyond normal safety precautions.

---

 **WARNING**

---

A pump is a pressure vessel with rotating parts that can be hazardous. Any pressure vessel can explode, rupture, or discharge its contents if sufficiently over pressurized causing death, personal injury, property damage, and/or damage to the environment. All necessary measures must be taken to ensure over pressurization does not occur.

---

 **WARNING**

---

Operation of any pumping system with a blocked suction and discharge must be avoided in all cases. Operation, even for a brief period under these conditions, can cause superheating of enclosed pumpage and result in a violent explosion. All necessary measures must be taken by the end user to ensure this condition is avoided.

---

 **WARNING**

---

The pump may handle hazardous and/or toxic fluids. Care must be taken to identify the contents of the pump and eliminate the possibility of exposure, particularly if hazardous and/or toxic. Potential hazards include, but are not limited to, high temperature, flammable, acidic, caustic, explosive, and other risks.

---

 **WARNING**

---

Pumping equipment Instruction, Operation, and Maintenance manuals clearly identify accepted methods for disassembling pumping units. These methods must be adhered to. Specifically, applying heat to impellers and/or impeller retaining devices to aid in their removal is strictly forbidden. Trapped liquid can rapidly expand and result in a violent explosion and injury.

ITT Goulds Pumps will not accept responsibility for physical injury, damage, or delays caused by a failure to observe the instructions for installation, operation, and maintenance contained in this Pump Safety Manual or the current IOM available at [www.gouldspumps.com/literature](http://www.gouldspumps.com/literature).

# SAFETY

## DEFINITIONS

Throughout this manual the words **WARNING**, **CAUTION**, **ELECTRICAL**, and **ATEX** are used to indicate where special operator attention is required.

**Observe all Cautions and Warnings highlighted in this Pump Safety Manual and the IOM provided with your equipment.**



### **WARNING**

Indicates a hazardous situation which, if not avoided, could result in death or serious injury.

**Example:** Pump shall never be operated without coupling guard installed correctly.

---



### **CAUTION**

Indicates a hazardous situation which, if not avoided, could result in minor or moderate injury.

**Example:** Throttling flow from the suction side may cause cavitation and pump damage.

---



### **ELECTRICAL HAZARD**

Indicates the possibility of electrical risks if directions are not followed.

**Example:** Lock out driver power to prevent electric shock, accidental start-up, and physical injury.

---



When installed in potentially explosive atmospheres, the instructions that follow the Ex symbol must be followed. Personal injury and/or equipment damage may occur if these instructions are not followed. If there is any question regarding these requirements or if the equipment is to be modified, please contact an ITT Goulds Pumps representative before proceeding.







**Example:**  Improper impeller adjustment could cause contact between the rotating and stationary parts, resulting in a spark and heat generation.













---



## GENERAL PRECAUTIONS

### WARNING

A pump is a pressure vessel with rotating parts that can be hazardous. Hazardous fluids may be contained by the pump including high temperature, flammable, acidic, caustic, explosive, and other risks. Operators and maintenance personnel must realize this and follow safety measures. Personal injuries will result if procedures outlined in this manual are not followed. ITT Goulds Pumps will not accept responsibility for physical injury, damage or delays caused by a failure to observe the instructions in this manual and the IOM provided with your equipment.

General Precautions		
WARNING		NEVER APPLY HEAT TO REMOVE IMPELLER. It may explode due to trapped liquid.
WARNING		NEVER use heat to disassemble pump due to risk of explosion from tapped liquid.
WARNING		NEVER operate pump without coupling guard correctly installed.
WARNING		NEVER run pump below recommended minimum flow when dry, or without prime.
WARNING		ALWAYS lock out power to the driver before performing pump maintenance.
WARNING		NEVER operate pump without safety devices installed.
WARNING		NEVER operate pump with discharge valve closed.
WARNING		NEVER operate pump with suction valve closed.
WARNING		DO NOT change service application without approval of an authorized ITT Goulds Pumps representative.
WARNING		<p><b>Safety Apparel:</b></p> <ul style="list-style-type: none"> <li>♦ Insulated work gloves when handling hot bearings or using bearing heater</li> <li>♦ Heavy work gloves when handling parts with sharp edges, especially impellers</li> <li>♦ Safety glasses (with side shields) for eye protection</li> <li>♦ Steel-toed shoes for foot protection when handling parts, heavy tools, etc.</li> <li>♦ Other personal protective equipment to protect against hazardous/toxic fluids</li> </ul>
WARNING		<p><b>Receiving:</b></p> <p>Assembled pumping units and their components are heavy. Failure to properly lift and support equipment can result in serious physical injury and/or equipment damage. Lift equipment only at specifically identified lifting points or as instructed in the current IOM. Current manuals are available at <a href="http://www.gouldspumps.com/literature_ioms.html">www.gouldspumps.com/literature_ioms.html</a> or from your local ITT Goulds Pumps sales representative. Note: Lifting devices (eyebolts, slings, spreaders, etc.) must be rated, selected, and used for the entire load being lifted.</p>
WARNING		<p><b>Alignment:</b></p> <p>Shaft alignment procedures must be followed to prevent catastrophic failure of drive components or unintended contact of rotating parts. Follow coupling manufacturer's coupling installation and operation procedures.</p>

<b>General Precautions</b>		
<b>WARNING</b>		Before beginning any alignment procedure, make sure driver power is locked out. Failure to lock out driver power will result in serious physical injury.
<b>CAUTION</b>		<b>Piping:</b> Never draw piping into place by forcing at the flanged connections of the pump. This may impose dangerous strains on the unit and cause misalignment between pump and driver. Pipe strain will adversely effect the operation of the pump resulting in physical injury and damage to the equipment.
<b>WARNING</b>		<b>Flanged Connections:</b> Use only fasteners of the proper size and material.
<b>WARNING</b>		Replace all corroded fasteners.
<b>WARNING</b>		Ensure all fasteners are properly tightened and there are no missing fasteners.
<b>WARNING</b>		<b>Startup and Operation:</b> When installing in a potentially explosive environment, please ensure that the motor is properly certified.
<b>WARNING</b>		Operating pump in reverse rotation may result in contact of metal parts, heat generation, and breach of containment.
<b>WARNING</b>		Lock out driver power to prevent accidental start-up and physical injury.
<b>WARNING</b>		The impeller clearance setting procedure must be followed. Improperly setting the clearance or not following any of the proper procedures can result in sparks, unexpected heat generation and equipment damage.
<b>WARNING</b>		If using a cartridge mechanical seal, the centering clips must be installed and set screws loosened prior to setting impeller clearance. Failure to do so could result in sparks, heat generation, and mechanical seal damage.
<b>WARNING</b>		The coupling used in an ATEX classified environment must be properly certified and must be constructed from a non-sparking material.
<b>WARNING</b>		Never operate a pump without coupling guard properly installed. Personal injury will occur if pump is run without coupling guard.
<b>WARNING</b>		Make sure to properly lubricate the bearings. Failure to do so may result in excess heat generation, sparks, and / or premature failure.
<b>CAUTION</b>		The mechanical seal used in an ATEX classified environment must be properly certified. Prior to start up, ensure all points of potential leakage of process fluid to the work environment are closed.
<b>CAUTION</b>		Never operate the pump without liquid supplied to mechanical seal. Running a mechanical seal dry, even for a few seconds, can cause seal damage and must be avoided. Physical injury can occur if mechanical seal fails.
<b>WARNING</b>		Never attempt to replace packing until the driver is properly locked out and the coupling spacer is removed.
<b>WARNING</b>		Dynamic seals are not allowed in an ATEX classified environment.
<b>WARNING</b>		<b>DO NOT</b> operate pump below minimum rated flows or with suction and/or discharge valve closed. These conditions may create an explosive hazard due to vaporization of pumpage and can quickly lead to pump failure and physical injury.

<b>General Precautions</b>		
<b>WARNING</b>		Ensure pump is isolated from system and pressure is relieved before disassembling pump, removing plugs, opening vent or drain valves, or disconnecting piping.
<b>WARNING</b>		<b>Shutdown, Disassembly, and Reassembly:</b> Pump components can be heavy. Proper methods of lifting must be employed to avoid physical injury and/or equipment damage. Steel toed shoes must be worn at all times.
<b>WARNING</b>		The pump may handle hazardous and/or toxic fluids. Observe proper decontamination procedures. Proper personal protective equipment should be worn. Precautions must be taken to prevent physical injury. Pumpage must be handled and disposed of in conformance with applicable environmental regulations.
<b>WARNING</b>		Operator must be aware of pumpage and safety precautions to prevent physical injury.
<b>WARNING</b>		Lock out driver power to prevent accidental startup and physical injury.
<b>CAUTION</b>		Allow all system and pump components to cool before handling them to prevent physical injury.
<b>CAUTION</b>		If pump is a Model NM3171, NM3196, 3198, 3298, V3298, SP3298, 4150, 4550, or 3107, there may be a risk of static electric discharge from plastic parts that are not properly grounded. If pumped fluid is non-conductive, pump should be drained and flushed with a conductive fluid under conditions that will not allow for a spark to be released to the atmosphere.
<b>WARNING</b>		Never apply heat to remove an impeller. The use of heat may cause an explosion due to trapped fluid, resulting in severe physical injury and property damage.
<b>CAUTION</b>		Wear heavy work gloves when handling impellers as sharp edges may cause physical injury.
<b>CAUTION</b>		Wear insulated gloves when using a bearing heater. Bearings will get hot and can cause physical injury.

## ATEX CONSIDERATIONS and INTENDED USE

Special care must be taken in potentially explosive environments to ensure that the equipment is properly maintained. This includes but is not limited to:

1. Monitoring the pump frame and liquid end temperature.
2. Maintaining proper bearing lubrication.
3. Ensuring that the pump is operated in the intended hydraulic range.

The ATEX conformance is only applicable when the pump unit is operated within its intended use. Operating, installing or maintaining the pump unit in any way that is not covered in the Instruction, Operation, and Maintenance manual (IOM) can cause serious personal injury or damage to the equipment. This includes any modification to the equipment or use of parts not provided by ITT Goulds Pumps. If there is any question regarding the intended use of the equipment, please contact an ITT Goulds representative before proceeding. Current IOMs are available at [www.gouldspumps.com/literature\\_ioms.html](http://www.gouldspumps.com/literature_ioms.html) or from your local ITT Goulds Pumps Sales representative.

All pumping unit (pump, seal, coupling, motor and pump accessories) certified for use in an ATEX classified environment, are identified by an ATEX tag secured to the pump or the baseplate on which it is mounted. A typical tag would look like this:



The CE and the Ex designate the ATEX compliance. The code directly below these symbols reads as follows:

- II = Group 2
- 2 = Category 2
- G/D = Gas and Dust present
- T4 = Temperature class, can be T1 to T6 (see Table 1)

<b>Code</b>	<b>Max permissible surface temperature °F (°C)</b>	<b>Max permissible liquid temperature °F (°C)</b>
T1	842 (450)	700 (372)
T2	572 (300)	530 (277)
T3	392 (200)	350 (177)
T4	275 (135)	235 (113)
T5	212 (100)	Option not available
T6	185 (85)	Option not available

The code classification marked on the equipment must be in accordance with the specified area where the equipment will be installed. If it is not, do not operate the equipment and contact your ITT Goulds Pumps sales representative before proceeding.

# PARTS



The use of genuine Goulds parts will provide the safest and most reliable operation of your pump. ITT Goulds Pumps ISO certification and quality control procedures ensure the parts are manufactured to the highest quality and safety levels.

Please contact your local Goulds representative for details on genuine Goulds parts.

---

# TABLE OF CONTENTS

## SAFETY

### NAMEPLATE INFORMATION

PAGE

#### SECTION I - GENERAL

Introduction .....	1
I-A Importance of Instructions .....	1
I-B Special Warnings.....	1
I-C Receiving and Inspection-Shortages.....	1
I-D Preservation and Storage.....	1

#### SECTION II - INSTALLATION INSTRUCTIONS

II-A Pump Handling .....	1
II-B Location of Unit.....	2
II-C Foundation.....	2
II-D Suction and Discharge Pipe .....	2
II-E V-Belt Drive – Alignment .....	2
II-F Direct Connect – Alignment.....	3
II-G Stuffing Box - Packing Installation.....	7

#### SECTION III - PUMP START-UP

III-A Pump Support.....	8
III-B Bearing Lubrication.....	8
III-C Shaft Rotation .....	8
III-D Impeller Clearance.....	8
III-E Correct Motor Rotation .....	8
III-F Stuffing Box Adjustment .....	9

#### SECTION IV - OPERATING AND MAINTENANCE INSTRUCTIONS

IV-A Lubrication .....	9
IV-B Stuffing Box - Lubrication Requirements.....	10
IV-C Maintaining Performance.....	11
IV-D End Cover Seals.....	11

#### SECTION V - DISASSEMBLY AND REASSEMBLY

V-A Disassembly of Pump.....	12
V-B Disassembly of Bearing Housing and Shaft Assembly .....	13
V-C Inspection and Replacement Parts Guidelines .....	13
V-D Reassembly of Bearing Housing and Shaft Assembly .....	14
V-E Reassembly of Pump .....	14
V-F Sectional View and Parts List.....	17

#### SECTION VI - CHECKLIST FOR LOCATING TROUBLE

VI-A Insufficient Capacity .....	19
VI-B Excessive Power Consumption .....	19
VI-C Pump Vibration .....	19

#### SECTION VII - REPLACEMENT PARTS

VII-A Ordering Replacement Parts .....	20
VII-B Reassembly of Bearing Housing and .....	20

#### SECTION VIII - MAINTENANCE TIPS

VIII-A Suction Cover Disassembly.....	21
VIII-B Impeller Removal.....	21
VIII-C Sleeve Removal.....	21
VIII-D Bearing Housing Assembly (B1, B2, B3, and B4 Frame).....	21

SECTION IX - SPECIAL TOOLS .....	22
----------------------------------	----

## SAFETY

### DEFINITIONS

This pump has been designed for safe and reliable operation. A pump is a pressure-containing device with rotating parts that could be hazardous. Operators and maintenance personnel must realize this and follow the necessary safety measures. Gould's Pumps Inc. shall not be liable for damage or delays caused by a failure to observe the instructions in this manual.

Throughout this manual the words **Warning**, **Caution**, and **Note** are used to indicate procedures and situations which require special operator attention:

**NOTE:** Operating procedure, condition, etc. which is essential to observe.

Examples:

### Warning

Pump shall never be operated without coupling guard correctly installed.

### Warning

Operating procedure, practice, etc. which, if not correctly followed, could result in personal injury or loss of life.

### Caution

Never completely restrict the discharge flow. May result in adverse temperature increase and possible explosion.

### Caution

Operating procedure, practice, etc. which, if not correctly followed, could result in damage or destruction of equipment.

**NOTE:** Proper alignment is essential for long pump life.

## GENERAL PRECAUTIONS

### Warning

Personal injuries will result if procedures outlined in this manual are not followed.

- Never operate pump without drive guard correctly installed.
- Never operate pump beyond the rated conditions to which the pump was sold.
- Never run pump below the recommended minimum flow or when dry.
- Always lock out power to the driver when performing pump maintenance.

- Never operate pump without safety devices installed.

- Never operate pump with discharge valve closed.

- Never use heat to disassemble pumps due to risk of explosion from trapped liquid.

- With the pump disconnected from the driver, check the motor rotation. Incorrect motor rotation can cause the impeller to back off of its threads and rupture the casing. It may also cause personal injury.

## SECTION I - GENERAL

### INTRODUCTION

This instruction manual is intended to assist those involved with the installation, operation, and maintenance of Goulds Model 5500 slurry pumps. It is recommended that this manual be thoroughly reviewed prior to installing or performing any work on the pump or motor.

#### I-A. IMPORTANCE OF INSTRUCTIONS

The design, material and workmanship incorporated in the construction of Goulds pumps make them capable of giving trouble-free service. The life and satisfactory service of any mechanical unit, however, is enhanced and extended by periodic inspection and careful maintenance. This instruction manual was prepared to assist operators in understanding the construction and correct methods of installing, operating, and maintaining these pumps.

Study this manual thoroughly, and carefully follow the instructions for installation and operation. Keep this manual available for reference. Further information can be obtained by contacting Goulds Pumps, Inc., Slurry Pump Division, Ashland, Pa. 17921 or your local representative.

#### I-B. SPECIAL WARNINGS

Goulds Pumps will not be liable for any damages or delay caused by failure to comply with the provisions of this instruction manual. This pump is not to be operated at speeds, working pressures, discharge pressures, or temperatures higher than, nor used with liquids other than, stated in the original order acknowledgement without written permission of Goulds Pumps, Inc.

#### I-C. RECEIVING AND INSPECTION SHORTAGES

Care should be taken when unloading pumps. If shipment is not delivered in good order and in accordance with the bill of lading, note the damage or shortage on both receipt and freight bill. **MAKE ANY CLAIMS TO THE TRANSPORTATION COMPANY PROMPTLY.**

#### I-D. PRESERVATION AND STORAGE

Goulds Pumps' normal domestic shipping and storage preparation is suitable for protecting the pump during shipment in covered trucks. It also provides protection during covered storage at the jobsite and for a short period between installation and start-up. If the pump is to be idle and exposed to the elements for an extended period, either before or after installation, Goulds Pumps' long-term storage procedures should be obtained and followed.

## SECTION II -- INSTALLATION INSTRUCTIONS

### II-A. PUMP HANDLING

Care must be taken in handling an assembled pump. Lifting lugs and eyebolts which may be on the pump are intended for use only with the individual parts, not for an entire bare pump. The recommended method for lifting of the entire pump is to attach to the two lifting lugs on the very top of the frame. See Fig. 2.

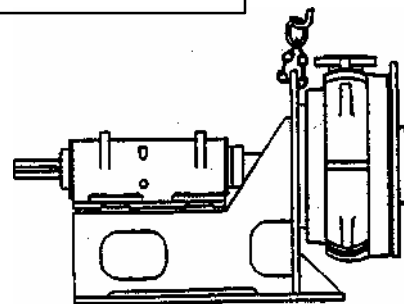

FIG. 2  
LIFTING TECHNIQUE -1-

## II-B. LOCATION OF UNIT

The pump should be located in an area free from flooding. The area should provide adequate space for maintenance and repair, considering complete disassembly and handling of equipment. The unit should be positioned to provide the most efficient pipeline system.

## II-C. FOUNDATION

The foundation must be sufficiently substantial and level to give rigid support to the pump and to absorb any vibration. When necessary to support the pump on a steel structure, the unit must be placed as close as possible to the main supports.

Foundation bolts should be .125-.250" smaller in diameter than the pump frame hole size. The hole size is shown on the certified dimension drawing.

## II-D. SUCTION AND DISCHARGE PIPE

Provision must be made to support suction and discharge piping independently from the pump to prevent nozzle loads. Short, direct suction and discharge pipelines and a minimum of elbows and fittings result in the least amount of frictional losses and ideal operating conditions. Excessive friction losses in suction piping could cause cavitation. The suction must be kept free of air leaks, particularly in long lines or on conditions of suction lift. Flow regulating valves should not be located on the suction side of the pump. It is recommended that a check valve be used in the discharge line to protect the pump from reverse flow and excessive pressure during shutdown.

## II-E. V-BELT DRIVES

Well designed and properly installed V-belt drives are capable of running for years without maintenance. There are a few points that should be checked periodically.

### 1. SHEAVE ALIGNMENT

Alignment must be maintained for full power transmission, minimum vibration, and long drive life. A dial indicator can be used to check runout on the periphery and face of each sheave. A straight edge can be used to check the alignment of pump and drive sheaves according to Fig. 3.

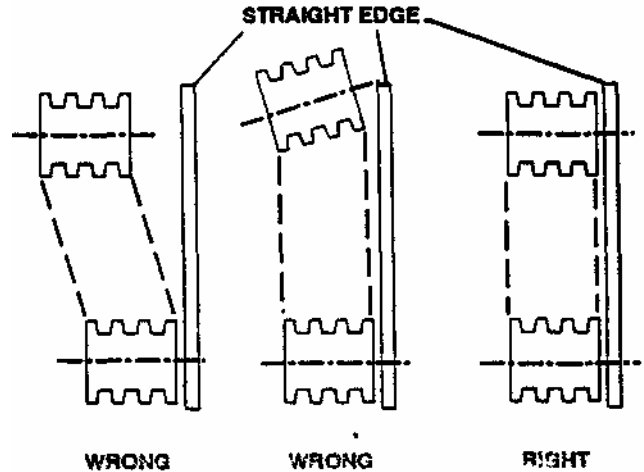

FIG. 3.  
CHECKING V-BELT SHEAVE  
ALIGNMENT

### 2. BELT INSTALLATION

When installing new belts, shorten center distance between sheaves so that belts can be put on without the use of force. NEVER "roll" or "pry" the belts into place, as this could damage the belt cords.

### 3. CHECK BELT FIT

Regardless of the belt section used, the belt should never be allowed to bottom in the groove. This will cause the belts to lose their wedging action and slippage can occur. Sheaves or belts that permit such a condition to occur should be changed.

### 4. BELT TENSION

Proper belt tension is the primary reason for long belt life. Improper tension could cause belt fatigue and/or hot bearings.

The general method for tensioning belts is given below, and should satisfy most drive requirements.

**STEP 1 :** Reduce the center distance so that the belts may be placed over the sheaves and in the grooves without forcing them over the sides of the grooves. Arrange the belts so that both the top and bottom spans have about the same sag. Apply tension to the belts by increasing the center distance until the belts are snug. See Fig. 4.

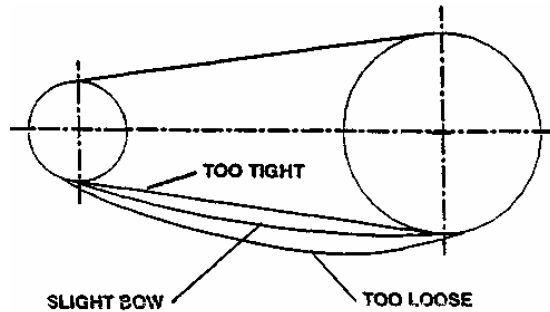

**FIG. 4**  
**V-BELT TENSION**

**STEP 2 :** Operate the drive a few minutes to seat the belts in the sheave grooves. Observe the operation of the drive under its highest load condition (usually starting). A slight bowing of the slack side of the drive indicates proper tension. If the slack side remains taut during the peak load, the drive is too tight. Excessive bowing or slippage indicates insufficient tension. If the belts squeal as the motor comes on or at some subsequent peak load, they are not tight enough to deliver the torque demanded by the drive motor. The drive should be stopped and the belts tightened.

**STEP 3 :** Check the tension on a new drive frequently during the first day by observing the slack side span. After a few days' operation the belts will seat themselves in the sheave grooves and it may become necessary to readjust the drive to show a slight bow in the slack side.

Other methods of determining proper belt tension can be obtained from the drive manufacturer.

## 5. USE BELT GUARDS

Belt guards protect personnel from danger and the drive from contamination. Inspect periodically to assure that belts do not rub against guard.

## 6. KEEP BELTS CLEAN

Dirt and grease reduce belt life. Belt dressing affects performance only temporarily and is NEVER recommended. Maintaining a clean drive is better practice.

If any questions arise pertaining to the drive limitations, consult the drive manufacturer.

## Warning

UNIT MUST NOT BE OPERATED WITHOUT PROPER DRIVE GUARDS IN PLACE. FAILURE TO OBSERVE THIS WARNING COULD RESULT IN PERSONAL INJURY TO OPERATING PERSONNEL.

## II-F. DIRECT CONNECTION

## Warning

BEFORE BEGINNING ANY ALIGNMENT PROCEDURE, MAKE SURE DRIVER POWER IS LOCKED OUT. FAILURE TO LOCK OUT DRIVER POWER WILL RESULT IN SERIOUS PHYSICAL INJURY.

Alignment is achieved by adding or removing shims from under the feet of the driver and shifting equipment horizontally as needed.

*NOTE: Proper alignment is the responsibility of the installer and user of the unit.*

Accurate alignment of the equipment must be attained. Trouble free operation can be accomplished by following these procedures.

## ALIGNMENT CHECKS

INITIAL ALIGNMENT (COLD ALIGNMENT)

- Before Grouting Baseplate - To ensure alignment can be obtained.

- After Grouting Baseplate - To ensure no changes have occurred during grouting process.

- After Connecting Piping - To ensure pipe strains haven't altered alignment. If changes have occurred, alter piping to remove pipe strains on pump flanges.

**FINAL ALIGNMENT (HOT ALIGNMENT)**

-After First Run - To obtain correct alignment when both pump and driver are at operating temperature. Thereafter, alignment should be checked periodically in accordance with plant operating procedures.

*NOTE: ALIGNMENT CHECK MUST BE MADE IF PROCESS TEMPERATURE CHANGES, PIPING CHANGES AND OR PUMP SERVICE IS PERFORMED.*

**ALIGNMENT CRITERIA**

Good alignment is achieved when the dial indicator readings as specified in the alignment procedure are .004" (.10 mm) Total Indicated Reading (T.I.R.) or less when the pump and driver are at operating temperature (Final Alignment). Misalignment over .004" (.10mm) may be allowed depending on the coupling type.

During the installation phase, however, it is necessary to set the parallel alignment in the vertical direction to a different criteria due to differences in expansion rates of the pump and driver. Table 1 shows recommended preliminary (cold) settings for electric motor driven pumps based on different pumpage temperatures. Driver manufacturers should be

<b>TABLE 1</b>	
<b>Cold Setting of Parallel Vertical Alignment</b>	
<b>PUMPAGE TEMPERATURE</b>	<b>SET DRIVER SHAFT</b>
<b>50°F (10°C)</b>	<b>.002in. (.05mm) LOW</b>
<b>150°F (65°C)</b>	<b>.001in. (.03mm) HIGH</b>
<b>250°F (120°C)</b>	<b>.005in. (.12mm) HIGH</b>

consulted for recommended cold settings for other types of drivers (steam turbines, engines, etc).

**SET UP**

1. Mount two dial indicators on one of the coupling halves (X) so they contact the other coupling half (Y) (Fig. 5).

2. Check setting of indicators by rotating coupling half X to ensure indicators stay in contact with coupling half Y but do not bottom out. Adjust indicators accordingly.

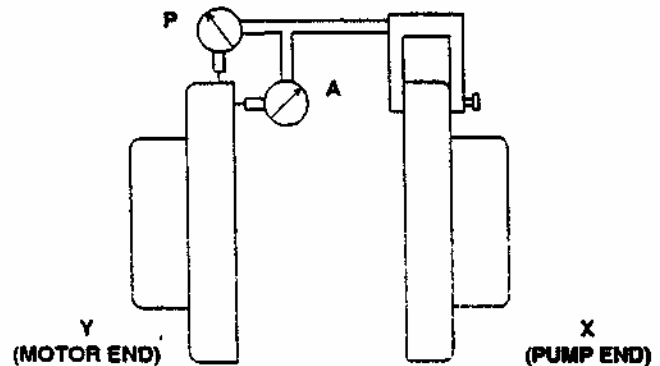

**FIG. 5.**  
**DIAL INDICATOR SET-UP.**

**MEASUREMENT**

1. To ensure accuracy of indicator readings, always rotate both coupling halves together so indicators contact the same point on coupling half Y. This will eliminate any measurement problems due to runout on coupling half Y.

2. Take indicator measurements with driver feet hold-down bolts tightened. Loosen hold down bolts prior to making alignment corrections.

3. Take care not to damage indicators when moving driver during alignment corrections.

**ANGULAR ALIGNMENT**

A unit is in angular alignment when indicator A (Angular indicator) does not vary by more than .004" (.10mm) as measured at four points 90° apart.

### VERTICAL CORRECTION (Top-to-Bottom)

1. Zero indicator A at top dead center (12 o'clock) of coupling half Y.

2. Rotate indicators to bottom dead center (6 o'clock). Observe needle and record reading.

3. **NEGATIVE READING** - The coupling halves are further apart at the bottom than the top. Correct by either raising the driver feet at the shaft end (add shims) or lowering the driver feet at the other end (remove shims), (Fig. 6A).

**POSITIVE READING** - The coupling halves are closer at the bottom than at the top. Correct by either lowering the driver feet at the shaft end (remove shims) or raising the driver feet at the other end (add shims).

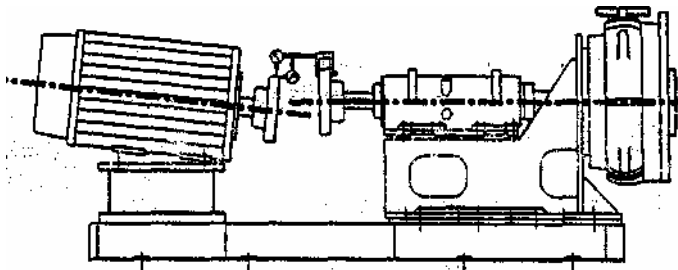

**FIG.6A**  
**VERTICAL CORRECTION OF THE MOTOR.**

4. Repeat steps 1-3 until indicator A reads .002" (.05mm) or less.

### HORIZONTAL CORRECTION (Side-to-Side)

1. Zero indicator A on left side of coupling half Y, 90° from top dead center (9 o'clock).

2. Rotate indicators through top dead center to the right side, 180° from the start (3 o'clock). Observe needle and record reading.

3. **NEGATIVE READING** - The coupling halves are further apart on the right side

than the left. Correct by either sliding the shaft end of the driver to the left or the other end to the right.

**POSITIVE READING** - The coupling halves are closer together on the right side than the left. Correct by either sliding the shaft end of the driver to the right or the other end to the left (Fig. 6B).

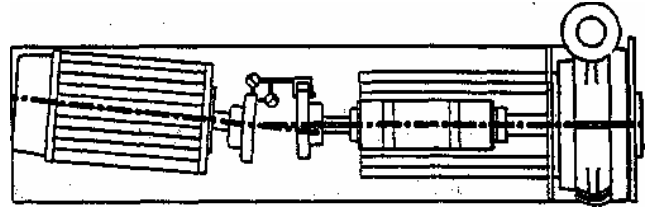

**FIG. 6B**  
**HORIZONTAL CORRECTION OF THE MOTOR.**

4. Repeat steps 1 through 3 until indicator A reads .004" (.10 mm) or less.

5. Re-check both horizontal and vertical readings to ensure adjustment of one did not disturb the other. Correct as necessary.

### PARALLEL ALIGNMENT

A unit is in parallel alignment when indicator P (parallel indicator) does not vary by more than .004" (.10mm) as measured at four points 90° apart at operating temperature. Note the preliminary vertical cold setting criteria, Table 1.

### VERTICAL CORRECTION (Top-to-Bottom)

1. Zero indicator P at top dead center of coupling half Y (12 o'clock) (Fig. 5).

2. Rotate indicator to bottom dead center (6 o'clock). Observe needle and record reading.

3. **NEGATIVE READING** - Coupling half X is lower than coupling half Y. Correct by removing shims of thickness equal to half of the indicator reading under each driver foot.

**POSITIVE READING** - Coupling half X is higher than coupling half Y. Correct by adding shims of thickness equal to half of the indicator reading from each driver foot (Fig. 7A).

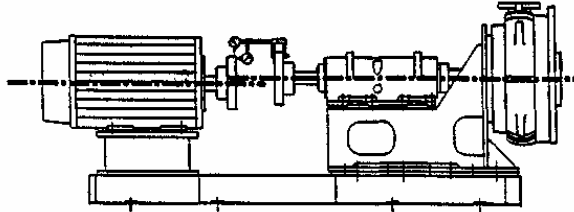

**FIG.7A**  
**VERTICAL CORRECTION OF MOTOR**

*NOTE: EQUAL AMOUNTS OF SHIMS MUST BE ADDED TO OR REMOVED FROM EACH DRIVER FOOT. OTHERWISE, THE VERTICAL ANGULAR ALIGNMENT WILL BE AFFECTED.*

4. Repeat steps 1 through 3 until indicator P reads within .004" (.10mm) or less when hot, or per Table 1 when cold.

**HORIZONTAL CORRECTION (Side-to-Side)**

1. Zero indicator P on the left side of coupling half Y, 90° from top dead center (9 o'clock).

2. Rotate indicators through top dead center to the right side, 180° from the start (3 o'clock). Observe needle and record reading.

3. **NEGATIVE READING** - Coupling half Y is to the left of coupling half X. Correct by sliding driver evenly in the appropriate direction (Fig. 7B).

**POSITIVE READING** - Coupling half Y is to the right of coupling half X. Correct by sliding driver evenly in the appropriate direction.

4. Repeat steps 1 through 3 until indicator P reads .004" (.10mm) or less.

5. Recheck both horizontal and vertical readings to ensure adjustment of one did not disturb the other. Correct as necessary.

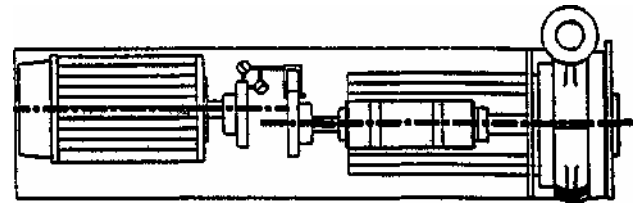

**FIG. 7B**  
**HORIZONTAL CORRECTION OF MOTOR**

**COMPLETE ALIGNMENT**

A unit is in complete alignment when both indicators A (angular) and P (parallel) do not vary by more than .004" (.10 mm) as measured at four points 90° apart.

**VERTICAL CORRECTION (Top-to-Bottom)**

1. Zero indicators A and P at top dead center (12 o'clock) of coupling half Y.

2. Rotate indicator to bottom dead center (6 o'clock). Observe the needles and record the readings.

3. Make corrections as outlined previously.

**HORIZONTAL CORRECTION (Side-to-Side)**

1. Zero indicators A and P on the left side of coupling half Y, 90° from top dead center (9 o'clock).

2. Rotate indicators through top dead center to the right side, 180° from the start (3 o'clock). Observe the needle, measure and record the reading.

3. Make corrections as outlined previously.

4. Recheck both vertical and horizontal readings to ensure adjustment of one did not disturb the other. Correct as necessary.

**TABLE 2  
ALIGNMENT TROUBLE SHOOTING**

PROBLEM	PROBABLE CAUSE	REMEDY
Cannot obtain horizontal (Side-to-Side) alignment, angular or parallel.	Driver feet bolt bound.	Loosen pump hold down bolts and slide pump and driver until horizontal alignment is achieved.
	Baseplate not leveled properly, probably twisted.	Determine which corner(s) of the baseplate are high or low and remove or add shims at the appropriate corner(s) and realign.
Cannot obtain vertical (Top-to-Bottom) alignment, angular or parallel.	Baseplate not leveled properly, probably bowed.	Determine if center of baseplate should be raised or lowered and correct by evenly adding or removing shims at the center of the baseplate.

**WARNING**

UNITS MUST NOT BE OPERATED WITHOUT PROPER DRIVE GUARDS IN PLACE, FAILURE TO OBSERVE THIS WARNING COULD RESULT IN PERSONAL INJURY TO OPERATING PERSONNEL.

**II-G. STUFFING BOX**

Goulds Model 5500 pumps are properly packed at the factory. The packing gland is set finger-tight and may require adjustment during start-up. Refer to section IV for stuffing box adjustment.

Connect pump with a supply of clean water for lubrication of the packing. See Section IV-B for the gland water supply requirements.

The lubricating liquid must be clean and free of grit. Shaft sleeve scoring, packing destruction, and mechanical seal face damage will result from contaminated lubricant.

**PACKING TYPE**

Original equipment packing is a suitable grade for the service intended.

**PACKING PROCEDURE**

a) Stuffing box and shaft sleeve must be clean and free of grit.

b) Form packing over shaft or mandrel of same diameter. Carefully cut to packing length. Discard rings cut too short.

c) Pre-form each ring by coiling 1 - 1/2 turns.

d) To install packing rings, do not pull straight. Expand the coil as a coil spring, see Fig. 8A and 8B for the correct and incorrect method of installing packing. Note the location of the lantern ring prior to packing installation. The lantern ring and packing locations are different for the weep and flush arrangements. See section V-F sectional view.

e) Expand the first coil as shown and insert into stuffing box. Tamp packing to stuffing box shoulder firmly with the gland.

*NOTE: NOTE THE POSITION OF THE CUT.*

f) Install the second and third coil as required by assembly drawing, staggering the cut 90° to 120°.

g) Insert lantern ring into stuffing box, carefully noting its proper position on the assembly drawing. Failure to properly locate the seal cage will result in insufficient packing lubrication. Packing and shaft sleeve damage may result.

h) After packing and lantern ring are properly installed, insert gland into stuffing box. Tighten gland nuts finger tight only. The shaft should turn freely.

i) Turn lubricant supply on, start pump, and adjust the gland as described in the pump start-up procedure.

j) Periodic maintenance is absolutely required for all packed pumps. Normal shaft run-out should be under .005" to avoid pounding of stuffing box packing. With excessive shaft run-out, shaft straightening or replacement is necessary.

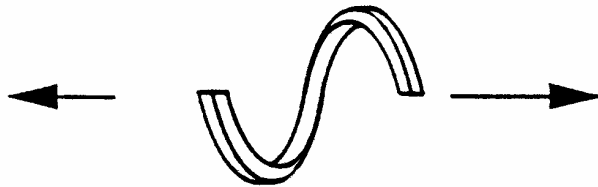

FIG. 8A.  
CORRECT

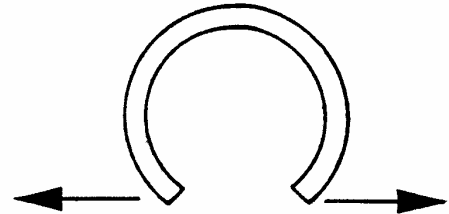

FIG. 8B.  
INCORRECT.

FIG. 8. STUFFING BOX PACKING

## SECTION III - PUMP START-UP

### III-A. PUMP SUPPORT

Before starting a new pump, check the pump foundation and piping to be certain that they conform to the specifications in the "Installation Instructions" Section II.

### III-B. BEARING LUBRICATION

Remove the bearing housing oil drain plug and drain the oil which may be used in assembly. Replace the oil drain plug and fill the bearing housing until the oil starts to come out the static oil level tap located on the side of the bearing housing. This indicates the proper oil fill level when pump is shut down. An oil sight gauge is also provided which indicates the appropriate oil level during operation. See lubrication section IV-A for recommended oil.

### III-C. SHAFT ROTATION

The pump shaft must turn without any binding or rubbing. By manually turning the rotating

element, only the uniform frictional drag of the bearings should be felt. If the pump does not turn freely, it should be checked to determine the cause of binding.

### III-D. IMPELLER CLEARANCE

The pump impeller clearance should be checked before start-up to assure proper positioning of the impeller to provide maximum efficiency and minimum wear. Refer to Section IV-C for impeller adjustment procedures.

## WARNING

CHECK MOTOR ROTATION BEFORE DRIVER IS COUPLED TO THE PUMP. REVERSE ROTATION COULD UNSCREW IMPELLER FROM SHAFT AND CAUSE CONSIDERABLE DAMAGE.

### III-E. CORRECT MOTOR ROTATION

Check the motor rotation to assure that it will drive the pump in the correct direction. The direction of rotation of the driver should be

checked before driver is coupled to the pump. Reverse rotation could unscrew the impeller, causing considerable damage. An arrow on the pump indicates the proper rotation, which is normally clockwise when viewed from the drive end.

The pump must be completely primed before operation.

**WARNING**

DO NOT OPERATE PUMP FOR PROLONGED PERIODS OF TIME WITH A CLOSED DISCHARGE VALVE. THE RESULTING HEAT BUILD-UP COULD LEAD TO PUMP FAILURE AND POSSIBLE PERSONAL INJURY TO OPERATING PERSONNEL.

**III-F. STUFFING BOX ADJUSTMENT**

During the first few hours of operation:

**1. Gland Adjustment** - Adjust the stuffing box if packing is used. When the pump is first started, there should be considerable leakage by the gland to cool the packing. Gradually tighten the gland nuts one flat at a time while observing the leakage and the stuffing box temperature. Packing requires time to "run in" and extra coolant (leakage) while it is being "run in". If the leakage is reduced too quickly, the packing will overheat and may be destroyed. The shaft sleeve may also be damaged.

**2. Leakage** - The normal leakage for a properly adjusted stuffing box, depending on shaft size and speed, varies from a few drops a second to a small trickle out of the gland.

**SECTION IV - OPERATING AND MAINTENANCE INSTRUCTIONS**

**IV-A. LUBRICATION**

Periodically check the oil level using the sight glass when the pump is operating, or the oil fill plug when the pump is stopped. Change the oil every 1000 hours. If the bearing assembly is exposed to dirty or moist conditions, the oil should be changed more often.

This bearing uses an oil bath lubrication. Oil lubricated bearing assemblies are shipped without oil. The recommended amount of oil to order based on the bearing housing size is shown in Tab. 3. Add oil to the housing until it is visible in the center of the indicator. Oil must be added to the bearing housing before starting.

**CAUTION**

DO NOT USE THE AMOUNT SPECIFIED IN TAB. 3. FILL TO THE CENTER OF THE INDICATOR.

TABLE 3 QUANTITY OF OIL TO ORDER	
FRAME SIZE	QUANTITY (Qts.)
B1	2
B2	5
B3	6
B4	11
B5	23

Spin pumps to fill splash reservoirs in the bearing housing. Check oil level indicator and add oil accordingly. Monitor oil level indicator for the first 24 hours of operation and maintain fill level.

If the unit has an external oil lube system, fill the bearing housing and the reservoir to satisfy the system requirements.

The viscosity of the oil should be 150 SSU at the operating temperature to prevent accelerated bearing wear.

For the best results, the minimum oil viscosity should be maintained as shown in Tab. 4:

TABLE 4 MINIMUM MAINTAINED OIL VISCOSITY	
OPERATING TEMPERATURE	GEAR OIL
Below 160°F Below 180°F Below 210°F	SAE40 SAE 50 or 90 SAE140

Industrial type petroleum based rust and oxidation inhibited oil or synthetic lubricants are recommended. Use of oil with extreme pressure additive is optional.

### CAUTION

OPERATION OF THE UNIT WITHOUT PROPER LUBRICATION CAN RESULT IN OVERHEATING OF BEARINGS, BEARING FAILURES, PUMP SEIZURES, AND ACTUAL BREAKUP OF EQUIPMENT, EXPOSING OPERATING PERSONNEL TO POSSIBLE INJURY.

#### IV-B. STUFFING BOX

The stuffing box is supplied with water connections for both the weep type and full flush configurations. Fig. 9 illustrates these two alternatives. The stuffing box cover is marked with an "F" and a "W" to show the proper locations for full flush or weep style connections. Fig. 9 also shows the proper number of rings of

packing required to yield the correct locations for the lantern ring and gland. Make sure that the stuffing box and shaft sleeve are clean before packing a pump. Also verify that the lantern ring is properly positioned to accept the flush water.

Do not over tighten gland nuts. Overtightened packing causes excessive friction between packing and sleeve and will result in damaged components.

The flush water requirements are listed in Tab. 5 for both the weep style and full flush packing arrangements.

TABLE 5 FLUSH WATER REQUIREMENTS			
Frame	Sleeve O.D.	(W) Weep GPM	(F) Full GPM
B1	2.50	.25	19
B2	3.75	.4	28
B3	5.00	.8	42
B4	6.25	1.5	55
B5	8.00	2.5	70

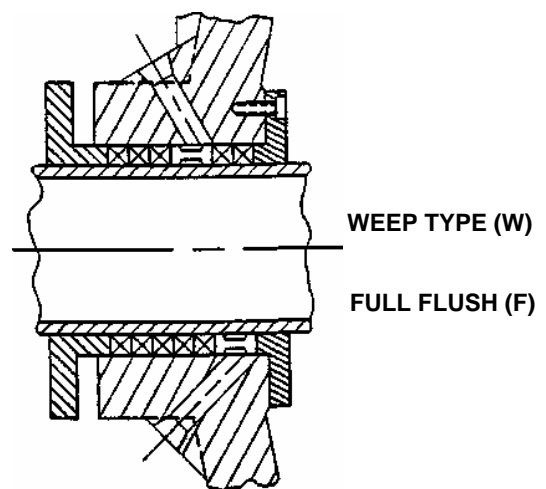

FIG. 9. TYPICAL STUFFING BOX.

To cover all possible situations, the gland water source should be capable of supplying water at a pressure approximately equal to the pump discharge pressure. Depending on the conditions of service, the required box pressure may be somewhat less. A valve should be installed in the gland water line to limit pressure to the optimum for the actual conditions of service. Excessive pressure will increase water consumption, gland water leakage and shaft sleeve wear.

A full flush box will give the best protection in abrasive applications. The flush water should be turned on before pump is started and left on for a short period of time after pump is stopped.

Some units may be supplied with an expeller and a grease packed stuffing box. For these situations, the weep style arrangement is normally used in conjunction with a grease cup or weight loaded greaser.

Periodic maintenance is absolutely required for all packed pumps.

Note: If a mechanical seal is to be installed in the pump there is some clearance available to center the stuffing box around the shaft by moving it in the frame to meet the instructions supplied with the seal. Use a dial indicator to properly locate the seal to the stuffing box and shaft.

#### **IV-C. MAINTAINING PERFORMANCE**

The pump flow and discharge head will decrease as wear occurs between the impeller front shroud and the suction cover. To maintain optimum pump performance and minimize the effects of wear, the impeller clearance should be adjusted periodically. Use the following procedure to set impeller adjustment:

#### **IMPELLER ADJUSTMENT PROCEDURE**

1. Stop pump. Do not attempt adjustment on a running pump.
2. Loosen the eight bearing housing locking screws (370C).
3. Use impeller adjustment screw (370D) to move impeller forward until it makes contact with the suction cover. Then back impeller away from suction cover approximately 1/32" (1/4 turn on impeller adjusting nut) or until impeller turns freely.
4. Lock adjustment screw (370D) in place and secure bearing housing using the bearing housing clamps (402) and bearing housing locking screws (370C).
5. Rotate shaft to insure all parts turn freely.

#### **IV-D. END COVER SEALS**

End cover seals (332, 332A, 333, 333A) must be lubricated to purge contaminants away from the bearing housing. Remove the pipe plugs from the bottom of both end covers and apply grease to the fittings on top until grease flows from the tapped holes. Install the pipe plugs. The seals should be lubricated every 500 hours or as required to maintain grease between the seals.

## SECTION V - DISASSEMBLY AND REASSEMBLY

### V-A. DISASSEMBLY OF PUMP

1. Before disassembly, be sure pump frame (228) is secured to foundation.
2. Lock out power supply to motor.
3. Clean pump exterior to prevent contamination of parts being disassembled.
4. Shut off valves controlling flow to and from the pump. Remove all gland water and auxiliary piping and tubing.
5. Loosen V-belts and remove or disconnect coupling from shaft. Follow drive manufacturer's instructions.
6. Drain oil from bearing housing (134) by removing pipe plug.
7. Unbolt and remove a section of the suction pipe. Drain pump.
8. Support suction cover liner (100B). This may be done through the use of the safety clips which are provided.

### WARNING

SUCTION COVER LINER MUST BE SUPPORTED BEFORE REMOVING SUCTION COVER. FAILURE TO DO SO COULD RESULT IN PERSONAL INJURY AND PROPERTY DAMAGE.

9. Unbolt and remove suction cover (182). (See Section VIII for Maintenance Tips.)
10. Remove suction cover liner (182). Remove gasket (351).
11. Unbolt split gland (107) and remove from stuffing box cover (184).
12. Slightly loosen bearing housing locking screws (370C), but do not remove. Unlock impeller adjusting screw (370D). Slide bearing housing and shaft assembly using impeller adjusting screw (370D) to extend impeller toward the suction side of the casing (100), resulting in better access to the impeller.

13. Remove knock-off deflector (123A). To do this, remove bolts that hold together the two halves of the split ring. Then remove set screws from knockoff deflector and use jacking screws to force knockoff deflector from shaft. Support the impeller (101) with a hook in the eye or a chain through a vane passage. A bar can be placed through the casing tee slots into the impeller to prevent rotation. A tool to support the impeller during disassembly and reassembly is available from Goulds Pumps Inc. Rotate shaft (122) to unscrew impeller. Impeller threads are righthand. At no time should heat be applied to the impeller hub or nose. The cavity at the impeller nose may contain moisture which when converted to steam could cause a violent explosion.

### WARNING

DO NOT APPLY HEAT TO HUB OR NOSE OF THREADED IMPELLER. DANGER OF EXPLOSION.

14. Remove fiber gasket (211) from between impeller (101) and sleeve (126).
15. Unbolt and remove casing (100) and gasket (360).
16. Remove optional expeller (262) if pump is so equipped.
17. Unbolt and remove stuffing box cover (184).
18. From stuffing box cover (184) remove stuffing box bushing (125), packing (106) and lantern ring (105).
19. Slide shaft sleeve (126) from shaft (122). Sleeve has a female threaded end to engage with a standard pipe thread. A sleeve puller tool is available from Goulds Pumps, Inc.
20. Remove bearing housing locking screws (370C) and bearing housing clamps (402).
21. Loosen impeller adjusting screw (370D) and lift bearing housing and shaft assembly from the frame (228).

## V-B. DISASSEMBLY OF BEARING HOUSING AND SHAFT ASSEMBLY

1. Remove inboard end cover (119).
2. Remove bearing locking screw (136A), if pump is so equipped (B5 frame only). The bearing locking screw protrudes into the inboard bearing. It is located on top of the bearing housing at the inboard bearing position.
3. Remove outboard end cover (109).
4. Carefully remove shaft (122) with both bearings from the outboard side of the bearing housing (134).
5. Inspect bearings completely. If bearings and shaft are in good condition, do not disassemble. Protect bearings from dirt and other contaminants.

**NOTE: HAVE REPLACEMENT BEARINGS AVAILABLE WHENEVER BEARINGS ARE TO BE REMOVED FROM THE SHAFT.**

6. To remove inboard bearing (168) from shaft, loosen setscrews on inboard bearing locknut (140) and unscrew (B5 frame only).
7. Remove inboard bearing (168) with an acceptable bearing puller. Loosen setscrews on oil thrower (114), if pump is so equipped, and slide out of the way of the bearing puller if necessary.
8. To remove outboard bearing (112), straighten tang in lockwasher (382A) and remove outboard bearing locknut (136) and keyed washer (140B). A keyed washer is not required on the B3 frame.
9. Remove outboard bearing (112) with an acceptable bearing puller. Loosen setscrews on oil thrower (114), if pump is so equipped, and slide out of the way of the bearing puller if necessary.
10. Remove oil seals (332, 332A, 333, 333A) from the bearing housing end covers. (Note the seal lip positions).

## V-C. INSPECTION AND PARTS REPLACEMENT GUIDELINES.

1. Impeller - Replace if impeller shows excessive erosion, corrosion, wear or vane breakage. Impeller hub must be in good condition. Reduction in hydraulic performance may be caused by excessive impeller wear, especially along the mating surface with the suction cover.
2. Suction Cover - Replace when impeller mating surface is overly worn and hydraulic performance has been significantly reduced. Consideration should be given to rotating the suction cover to equalize wear.
3. Shaft Sleeve - Sleeve surface in stuffing box must be smooth. Replace if badly grooved or cut.
4. Stuffing Box Bushing - Replace if bore is oversize or out-of-round.
5. Expeller - Replace if expeller shows excessive wear, erosion, corrosion, or vane breakage.
6. Casing - Replace if worn.
7. Shaft - Check for runout (.006" max.) to see that shaft has not been bent. Bearing seats and oil seal area must be smooth and free of scratches or grooves. Shaft threads must be in good condition. Replace if necessary.

*NOTE: IF BEARING REPLACEMENT IS NECESSARY, THE NEW BEARINGS INSTALLED SHOULD BE THE SAME BRAND AND CONSTRUCTION AS THE BEARINGS INSTALLED AT THE FACTORY. DESPITE MANUFACTURERS' CLAIMS, THERE IS A DIFFERENCE IN LOAD-CARRYING CAPACITY AND LIFE BETWEEN APPARENTLY INTERCHANGEABLE BEARINGS FROM VARIOUS MANUFACTURERS.*

8. Bearings - Replace if worn, loose, or rough and noisy when rotated.
9. Oil Seals - Replace if worn, damaged, or leaking.

## **V-D. REASSEMBLY OF BEARING HOUSING AND SHAFT ASSEMBLY.**

1. All parts should be cleaned thoroughly before assembly.
2. Check shaft for nicks or worn areas.
3. Press oil seals (332, 332A, 333, 333A) into both end covers (109, 119). Fill the cavity between the seals with grease. Inspect O-Ring (496) on outboard end cover (109) and replace if necessary.
4. Position oil thrower (114) on shaft and secure between bearing fits. B5 Frame only.
5. Press inboard bearing (168) onto shaft (122). For B5 frame, install inboard bearing locknut (140) and secure with setscrews.
6. Press outboard bearing (112) onto shaft (122).

*NOTE: WHEN BEARINGS ARE HEATED FOR INSTALLATION ON THE SHAFT, THE TEMPERATURE SHOULD NOT EXCEED 250°F. DO NOT USE A TORCH OR OPEN FLAME ON THE BEARINGS.*

7. Position keyed washer (1408) (not on B3 frame) and bearing lockwasher (382A) against the bearing shoulder. Tighten outboard bearing locknut (136). Bend tang of lockwasher to engage slot in locknut.
8. From the outboard side of the bearing housing (134), install shaft (122) with both bearings into the bearing housing (134). For inboard spherical roller bearings (B1, B2, B3, and B4 frames) care must be taken to keep the outside race from misaligning. A tool to help maintain alignment is available from Goulds Pumps, Inc. For the B5 frame, position hole in inboard bearing outer race so that it will engage properly with the inboard bearing locking screw (136A). A 1/16" gasket washer must be used under the head of the locking screw (136A) before it is tightened. Make certain that locking screw (136A) does not bottom in the bearing.

9. Attach inboard end cover (119) and gasket (360N). Avoid damaging the seals.
10. Attach outboard end cover (109). Avoid damaging the O-Ring and seals. Note that there should be a nominal .063" gap between the end cover (109) and the bearing housing (134). Do not overtighten capscrews (370N).
11. Install knock-off deflector (123A) onto shaft against shoulder.
12. Rotate shaft to assure all parts are free.

## **V-E REASSEMBLY OF PUMP**

1. Check that frame (228) is securely bolted to the foundation. Clean frame (228). The top of the frame must be clean and burr free where it meets the bearing housing (134).
2. Coat the bearing housing to frame fit with an anti-seizing compound such as "Never Seez" or equal.
3. Position impeller adjusting nuts (370D) apart and place reassembled bearing housing assembly into frame (228).
4. Attach bearing housing clamps (402) with bearing housing locking screws (370C).
5. Apply a small bead of silicone sealant around the shaft 0.25" from the knock off deflector (123A). Coat inside of sleeve with an anti-seizing compound such as "Never Seez" or equal. Slide shaft sleeve (126) onto shaft (122).
6. Install lantern ring (105) on shaft (122) back toward the inboard end cover (119).
7. Insert stuffing box cover (184) into frame (228) and secure studs (370H).
8. Install stuffing box bushing (125) into stuffing box cover (184) and secure hex socket cap screws (459).

9. Place fiber gasket (211) against end of shaft sleeve (126).

10. Install optional expeller (262), if so equipped, over the shaft sleeve.

11. Attach gasket (360) to stuffing box cover (184) with a gasket adhesive.

12. Bolt casing (100) to frame (228) using studs (370B) and hex nuts. Tighten to the values shown in the casing Bolt-Torque chart, Table 6.

13. Slightly loosen bearing housing locking screws (370C)—DO NOT REMOVE and slide bearing housing shaft assembly so that the impeller end of the shaft extends as far as possible toward the suction cover (182). Use the impeller adjusting screw (370D) to position the shaft.

14. Place fiber gasket (563) on the end of expeller, if so equipped. Apply a light coating of grease on the gasket to eliminate tears during tightening.

15. Apply an anti-seizing compound to the shaft threads. Support threaded impeller (101) at the beginning of the shaft (122) and prevent impeller (101) from turning. Rotate shaft (122) to tighten impeller (101) onto shaft (122). Impeller threads are right hand threads.

16. Move impeller (101) toward back wall of casing (100) as far as possible by turning the impeller adjusting nuts (370D).

17. Attach gasket (351) to suction cover (182) using gasket adhesive.

18. Position suction cover (182) into casing (100) and support. A flat bar can be positioned through the tee slots to give support, or the safety clips which are supplied with the pump should be used at this time.

19. Position suction cover clamp (452) over suction cover (182) and bolt in place with bolts (370A). Hand tighten all bolts first. Tighten all bolts evenly using a criss-cross method shown in Fig. (10). Wrench tighten bolts repeatedly using the criss-cross pattern until the torque value listed in Table 6 is reached.

20. Adjust impeller (101) using the impeller adjusting screw (370D) so that the impeller (101) slightly rubs the suction cover. Back off the impeller approximately 1/32" (1/4 turn of the impeller adjusting nut) or until it turns freely. Lock adjusting screws (370D).

21. Tighten bearing housing clamps (402) with bearing housing locking screws (370D).

TABLE 6 5500 CASING BOLT TORQUE VALUES		
LUBRICATE THREADS BEFORE TIGHTENING		
PUMP SIZE	TORQUE (FT. LBS.) SUCTION SIDE (LUBRICATED)	TORQUE (FT. LBS.) STUFFING BOX SIDE (LUBRICATED)
3x4-12	24-29	31-36
3x4-17	160-175	63-69
3x4-18	160-175	63-69
3x4-1 8HP	273-300	105-115
4x6-15	41-45	63-69
4x6-21	113-125	82-90
4x6-29	167-182	108-120
4x6-29HP	334-365	216-235
6x6-18	69-77	123-135
6x8-19	76-85	123-135
6x6-22	113-125	82-90
6x8-26	207-225	125-140
6x8-26HP	356-400	216-235
8x10-21	113-125	82-90
8x10-29	190-210	116-125
10x12-25	77-85	172-190
10x12-34	200-220	116-125
12x14-29	102-115	172-190
12x14-38	207-228	160-175
14x16-42	174-200	106-120

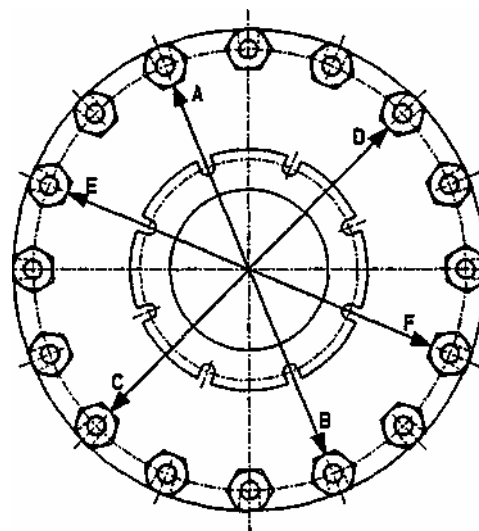

FIG. (10)

22. Rotate shaft to assure all parts are free.

23. Pack pump with square packing (106). See Tab. 7, Packing Chart below. With the weep (W) arrangement, install two rows into the stuffing box cover (184) before the lantern ring (105) and five rows after the lantern ring (105). For full flush (F) water inlets, install the lantern ring (105) before seven rows of packing. Make certain that lantern ring is properly positioned to receive the flush water.

TABLE 7 PACKING CHART		
FRAME	SLEEVE O.D.	PACKING SIZE
B1	2.50	7/16"
B2	3.75	1/2"
B3	5.00	5/8"
B4	6.25	3/4"
B5	8.00	3/4"

24. Position both halves of the gland (107) around the shaft sleeve (126) and bolt together. Push packing into box by tightening gland studs (353) against gland (107) evenly. See section on Operating and Maintenance Instructions for information regarding stuffing box water requirements.

25. Attach suction, discharge, and auxiliary piping.

26. Check drive or coupling alignment as noted in Section II.

27. Follow procedures listed under "Pump Start-Up" for proper lubrication requirements. Be sure to add oil to the bearing housing prior to running the pump.

SECTION V-F. SECTIONAL VIEW & PARTS LIST

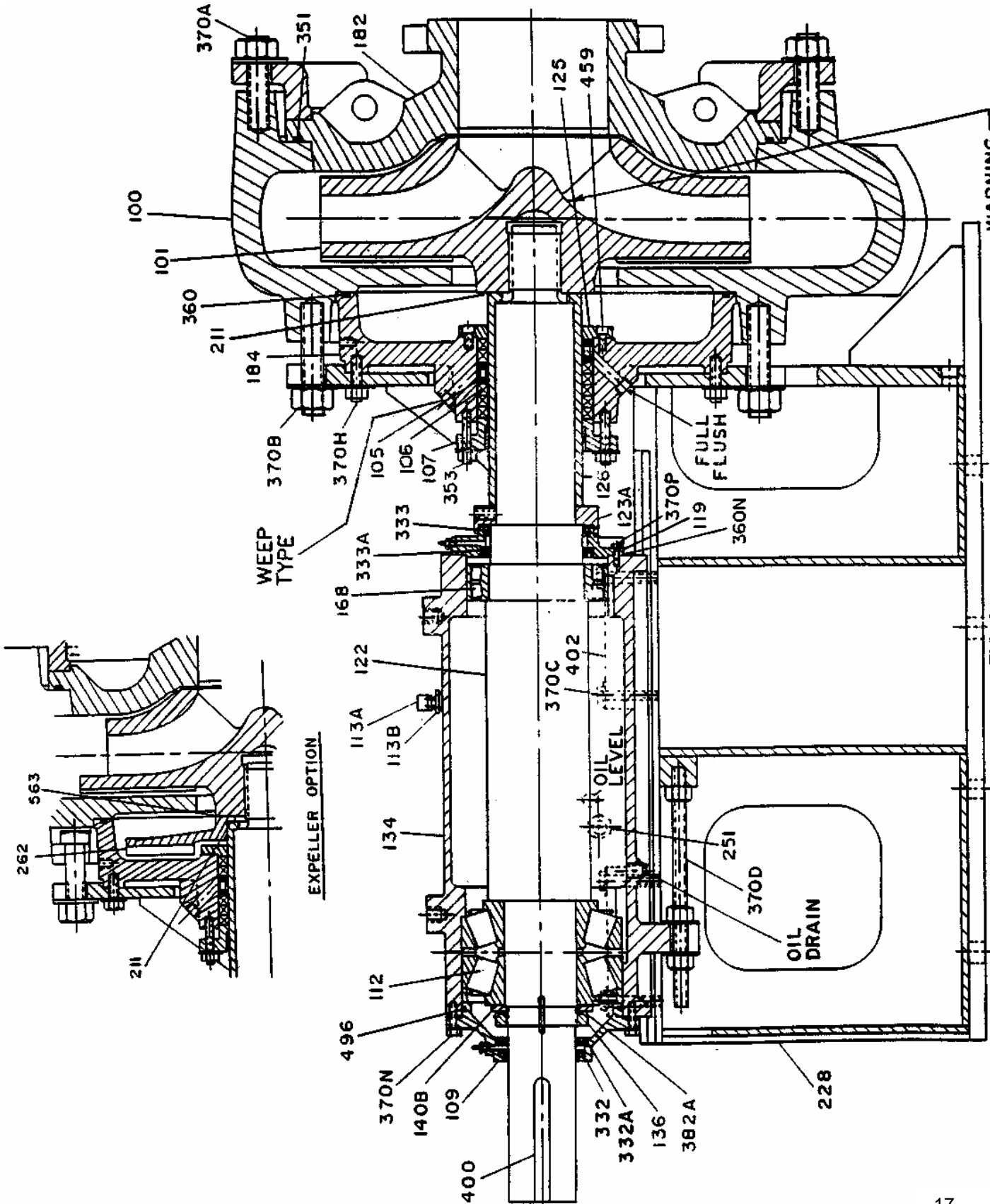

WARNING  
DO NOT APPLY HEAT  
TO NOSE OF IMPELLER  
DANGER OF EXPLOSION!

FIG. 9.  
SECTIONAL DRAWING OF THE 5500.  
(SEE NEXT PAGE FOR THE BILL OF MATERIALS)

## 5500 BILL OF MATERIAL

ITEM NO.	QTY. PER PUMP	PART NAME
100	1	CASING
101	1	IMPELLER
105	1	LANTERN RING
106	1	PACKING
107	1	GLAND
109	1	OUTBOARD END COVER
112	1	OUTBOARD BEARING
113A	1	BREATHER
113B	1	OIL FILL BUSHING
114	1	OIL THROWER (NOT SHOWN)
119	1	INBOARD END COVER
122	1	SHAFT
123A	1	KNOCK OFF DEFLECTOR
125	1	STUFFING BOX BUSHING
126	1	SHAFT SLEEVE
134	1	BEARING HOUSING
136	1	OUTBOARD BEARING LOCKNUT
136A	1	INBOARD BEARING LOCKING SCREW (B5 ONLY, NOT SHOWN)
140	1	INBOARD BEARING LOCKNUT (NOT SHOWN)
140B	i	KEYED WASHER
168	1	INBOARD BEARING
182	1	SUCTION COVER
184	1	STUFFING BOX COVER
211	1	GASKET (101/262-126)
228	1	FRAME
251	1	OIL LEVEL SIGHT
262	1	EXPELLER (OPTIONAL)
332	1	OUTBOARD SEAL, OUTSIDE
332A	1	OUTBOARD SEAL, INSIDE
333	1	INBOARD SEAL, OUTSIDE
333A	1	INBOARD SEAL, INSIDE
351	1	O-RING (CASING-SUCTION COVER)
353	2	GLAND STUD
360	1	O-RING (CASING-STUFFING BOX)
360N	1	GASKET (INBOARD END COVER)
370A	8	SQ. HD BOLT (CASING, SUCTION SIDE)
370B	8	SQ. HD BOLT (CASING - FRAME)
370C	8	BEARING HOUSING LOCKING SCREW
370D	1	IMPELLER ADJUSTING SCREW
370H	2	STUDS (STUFFING BOX-FRAME)
370N	6	HEX CAP SCREWS (OUTBOARD END COVER)
370P	6	HEX CAP SCREWS (INBOARD END COVER)
382A	1	OUTBOARD BEARING LOCKWASHER
400	1	DRIVE KEY
402	8	BEARING HOUSING CLAMP
452	1	SUCTION COVER CLAMP
459	4	HEX SOCKET CAP SCREW
496	1	O-RING (OUTBOARD END COVER)
563	1	GASKET (EXPELLER - IMPELLER)

## SECTION VI - CHECKLIST FOR LOCATING TROUBLE

### VI-A. INSUFFICIENT CAPACITY

1. Pump not primed; check for air leaks in suction line.
2. Speed too low.
3. Total piping system head higher than pump rating.
4. Suction lift too great or insufficient NPSH of system.
5. Impeller passages partially blocked.
6. Suction line partially blocked.
7. Wrong direction of rotation.
8. Mechanical defects: impeller worn or damaged; defective gasket causing leakage.
9. Pumpage viscosity too high.

### VI-B. EXCESSIVE POWER CONSUMPTION

1. Speed too high.
2. Total piping system head lower than pump rating (pump will attempt to pump too much water).
3. Slurry being pumped has higher specific gravity than that for which pump is rated.
4. Mechanical defects: packing too tight; shaft bent, impeller rub, worn bearings, worn impeller or other water end parts.

### VI-C. PUMP VIBRATION

1. Foundation not sufficiently rigid.
2. Impeller partially blocked causing unbalance.
3. Misalignment.
4. Mechanical defects: shaft bent; worn bearings; impeller worn.
5. Insufficient net positive suction available (NPSHa)

## SECTION VII - REPLACEMENT PARTS

### VII-A. ORDERING REPLACEMENT PARTS

When ordering spare parts call

**1-800-4GOULDS  
(1-800-446-8537)**

or your local Goulds representative.

Repair orders will be handled with a minimum of delay if the following directions are followed:

1. Give model number, size of pump, and serial number. These can be obtained from the nameplate on the pump.
2. Write plainly the name and item number of each part required. These names and numbers should agree with those on the sectional drawings.
3. Give the quantity of parts required.
4. Give complete shipping instructions.

### VII-B. RECOMMENDED SPARE PARTS

To ensure against possible long and costly downtime periods, especially on critical services, it is advisable to carry some spare parts on hand. Goulds suggests the following spare parts be carried by the customer.

QTY.	ITEM NO.	ITEM
1	100	Casing
1	182	Suction Cover
1	126	Shaft Sleeve
1	101	Impeller
1	211	Gasket (Impeller to Sleeve)
1	351	Gasket (Casing to Suction Cover)
1	360	Gasket (Casing to Stuffing Box Cover)
1	168	Inboard Bearing
1	112	Outboard Bearing
1	333	Inboard Seal, Outside
1	333A	Inboard Seal, Inside
1	332	*Outboard Seal, Outside
1	332A	*Outboard Seal, Inside
1	122	*Shaft
1	459	Stuffing Box Bushing

If pump is equipped with an expeller, additional recommended parts are;

QTY.	ITEM NO.	ITEM
1	563	Gasket (Expeller to Impeller)
1	184	Stuffing Box Cover
1	262	Expeller

\*In place of the individual items, a customer may wish to carry a complete bearing housing and shaft assembly in stock.

In keeping with Goulds Slurry Pump Division policy, the majority of parts for this pump will be stocked in distributors' warehouses and at the Slurry Pump Division plant in Ashland, Pennsylvania.

SPECIAL NOTE: IN CASES WHERE PUMPS ARE FURNISHED WITH SPECIAL METALS, DELIVERIES ARE QUITE LENGTHY, IT IS THEREFORE ADVISABLE TO ANTICIPATE YOUR REQUIREMENTS SEVERAL MONTHS IN ADVANCE SO THAT POSSIBLE LONG DELIVERIES WILL NOT HANDICAP YOUR OPERATION.

## SECTION VIII - MAINTENANCE TIPS

### VIII-A. SUCTION COVER DISASSEMBLY

To disassemble the water end of the pump, the suction cover (182) should be supported. Two of the bolts (370A) holding the suction cover clamp (452) also hold the suction cover (182) from loosening unexpectedly via the attached safety clips. With the safety clips attached, all but two of the bolts can be removed by loosening slightly and sliding them out of the tee slots. The bolts with the safety clips cannot be removed until they are fully unscrewed and the suction cover clamp (452) is removed. Then the suction cover can be supported with a chain or cable and the safety clip assembly can be taken apart to release the suction cover (182) fully. The suction cover (182) has a tapered fit into the casing to ease disassembly. The suction cover can be loosened by using a pry bar between the tee slot flange and the outside diameter of the suction cover (182). Prying around the entire circumference will provide the best results.

### VIII-B. IMPELLER REMOVAL

To remove the impeller, the knock-off deflector (123A) should be removed first. This will release the tension in the impeller threads. The socket head cap screws and the socket head setscrews should be removed from the knock-off deflector to jack the deflector away from the shaft.

The shaft assembly should be moved toward the suction of the pump as far as possible by slightly loosening the bearing housing locking screws

(370C) (DO NOT REMOVE). Turn the impeller adjusting screw (370D). The largest amount of adjustment can be obtained by removing the gland (107). On pumps equipped with expellers (262), the amount of adjustment will be limited by the clearance between the expeller and the back wall of the casing (100). With the impeller as far out of the casing as possible, a bar, cable, or chain should be put into the impeller (101) to prevent it from rotating. Tighten the bearing housing locking screws to secure the shaft assembly. Turn the shaft from the drive end counterclockwise to loosen the impeller from the shaft. A special tool is available from Goulds Pumps, Inc., to turn the shaft. The impeller must be supported before the impeller is completely unscrewed. A special tool to hold the impeller is also available from Goulds Pumps, Inc.

### VIII-C. SLEEVE REMOVAL

The sleeve has an internal pipe thread on the impeller end. A pipe nipple of the correct size can be screwed in to provide an easy way to attach and pull the sleeve from the shaft. A special sleeve puller tool is also available from Goulds Pumps, Inc.

### VIII-D. BEARING HOUSING ASSEMBLY (B1, B2, B3, AND B4 FRAME)

A tool is available from Goulds Pumps, Inc. to ease assembly of the bearings into the bearing housing. The spherical design of the inboard bearing requires that it must be supported to maintain alignment with the shaft centerline. Proper alignment is essential for easy installation of the bearing into the housing. The bearing holder tool provides such support.

**SECTION IX -- SPECIAL TOOLS**

**TOOLS CAN GREATLY EASE MAINTENANCE**

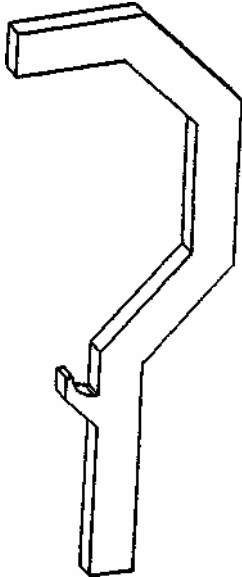

**FIG. 10**  
**IMPELLER HOOK**  
(to install & remove impeller from casing)

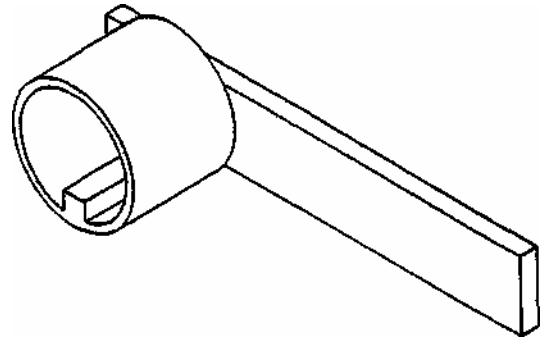

**FIG. 11**  
**SHAFT ROTATOR**  
(to install & remove impeller from casing)

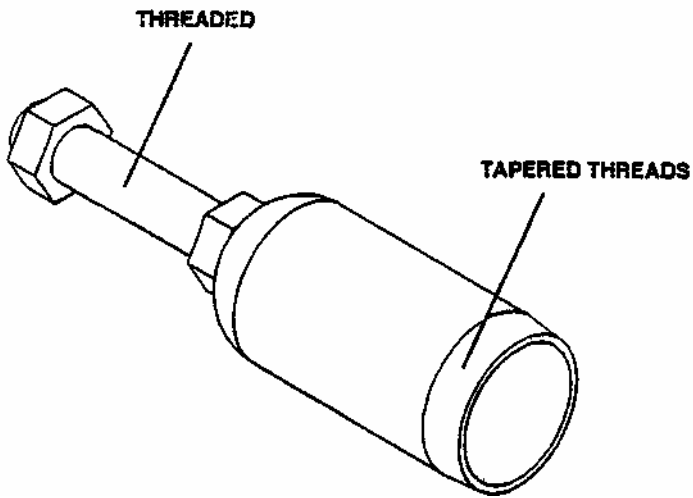

**FIG. 12**  
**SLEEVE PULLER**  
(to remove shaft sleeve)

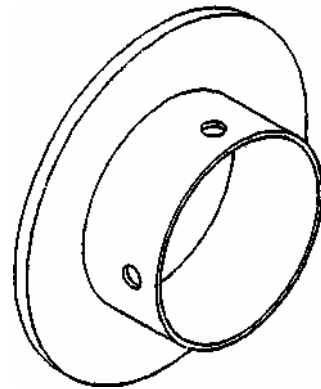

**FIG. 13**  
**BEARING HOLDER**  
(to install shaft & bearing assembly into bearing housing, for B3 & B4 frame only)





**GOULDS PUMPS, INC.  
SLURRY PUMP DIVISION  
EAST CENTRE STREET  
ASHLAND, PA 17921**