

Goulds 3400

Double Suction Pumps

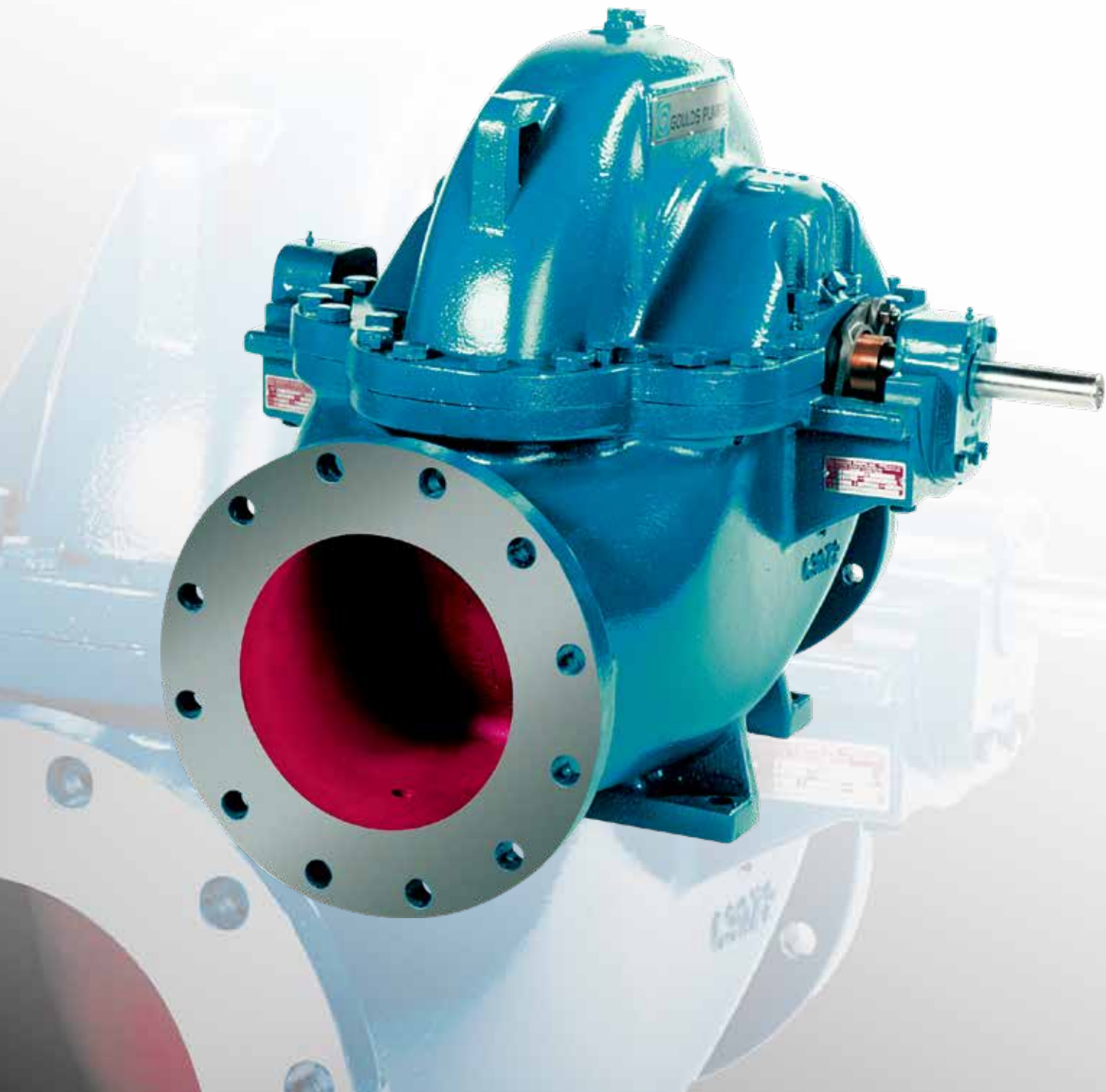

3400

Designing and Manufacturing Dependable Centrifugal Pumps for More Than 125 Years



Model 3498 pumping drinking water through a distribution network in the Western United States.



All 316 stainless steel model 3409 pumps on a solvent extraction application at a large copper mine.



Goulds split case pumps have many applications in the power generation market.



Model 3420 splitcase pump in service at an electric utility plant in the Bahamas.

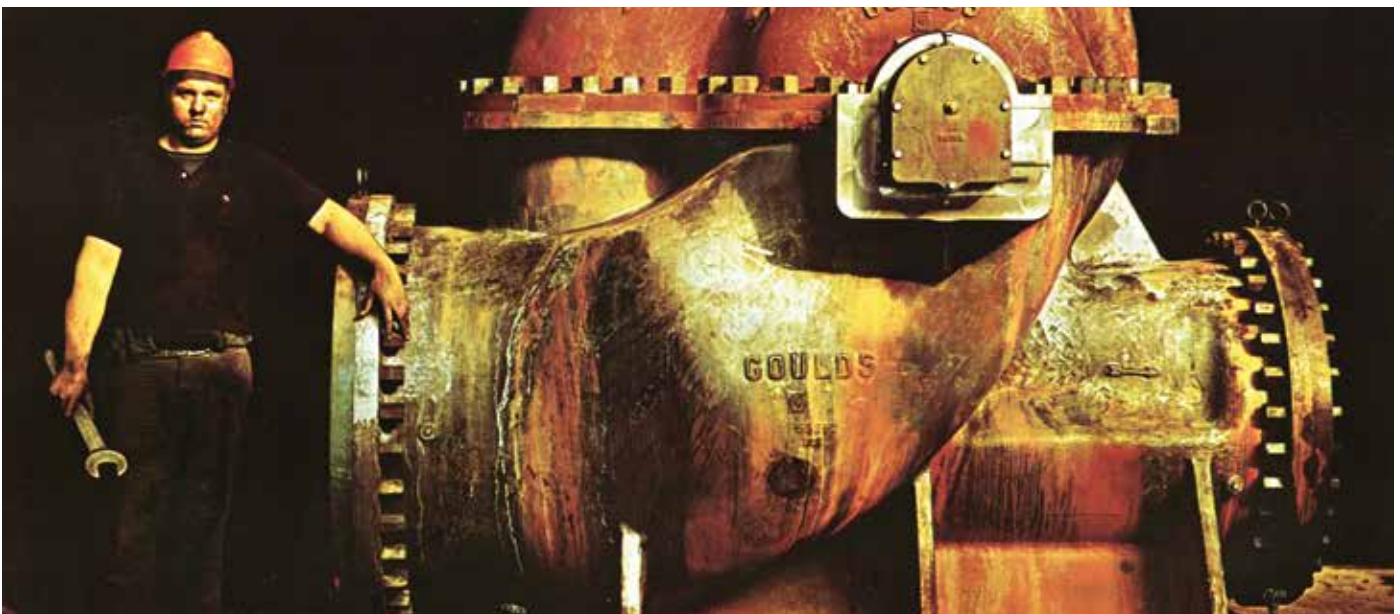

The Most Complete Line of Double Suction Pumps in the Industry



Small Capacity – 3410

Flows to 12,000 GPM

- Capacities to 12,000 GPM (2,725 m³/h)
- Heads to 530 feet TDH (162 m)
- Temperatures to 350° F (177° C)
- Working pressures to 250 PSI (1,724 kPa)

Medium Capacity – 3409

Flows to 12,000 GPM

- Capacities to 12,000 GPM (2,725m³/h)
- Heads to 850 feet TDH (259 m)
- Temperatures to 250° F (120° C)
- Working pressures to 400 PSI (2758 kPa)

Large Capacity – 3420

Flows to 65,000 GPM

- Capacities to 65,000 GPM (14,762 m³/h)
- Heads to 400 feet TDH (122 m)
- Temperatures to 275° F (135° C)
- Working pressures to 200 PSI (1379 kPa)

Extra Large Capacity – 3498

Flows to 225,000 GPM

- Capacities to 225,000 GPM (51,098m³/h)
- Heads to 800 feet TDH (244 m)
- Temperatures to 275° F (135° C)
- Working pressures to 250 PSI (1,724 kPa)

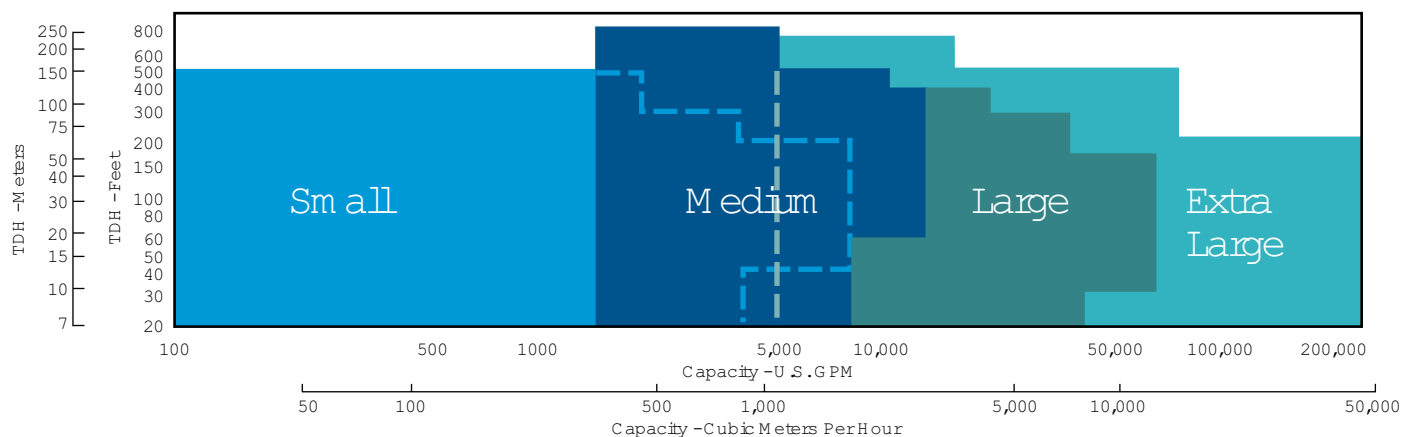

3400

Small Capacity

Model 3410

- Horizontal or Vertical Mounting
- Grease or flood oil lubricated bearings
- NPRO VBX labyrinth bearing isolators standard
- Dual volute casings on most sizes
- Alloy constructions not shown below are also available
- Packing or mechanical seals available (including cartridge and split type seals)

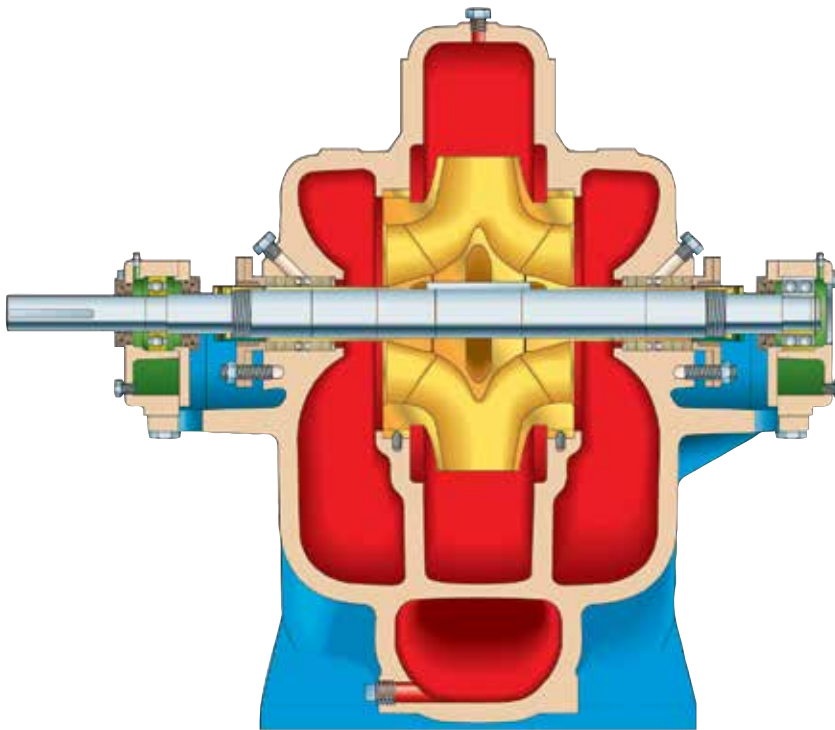

Materials of Construction

Part Description	Bronze Fitted	316 SS Fitted	All 316 SS
Casing	Cast Iron		316 SS
Impeller	Bronze	316 SS	
Lantern Ring	PTFE		
Packing	Graphite Impregnated Yarn		
Packing Gland	316 SS		
Mechanical Seal Gland	Cast Iron		316 SS
Shaft	Carbon Steel		
Shaft Sleeve Nut	Bronze	Nitronic 60	
Shaft Sleeve ¹	Bronze	316 SS	
Casing Wear Ring ¹	Bronze	Nitronic 60	
Bearing Housing	Cast Iron		
Impeller Wear Ring (optional) ¹	Bronze	316 SS	
Bearings	Steel (Anti-Friction)		

¹ Also available in hardened/hard metal coated materials.

Small Capacity con't

Dimensions

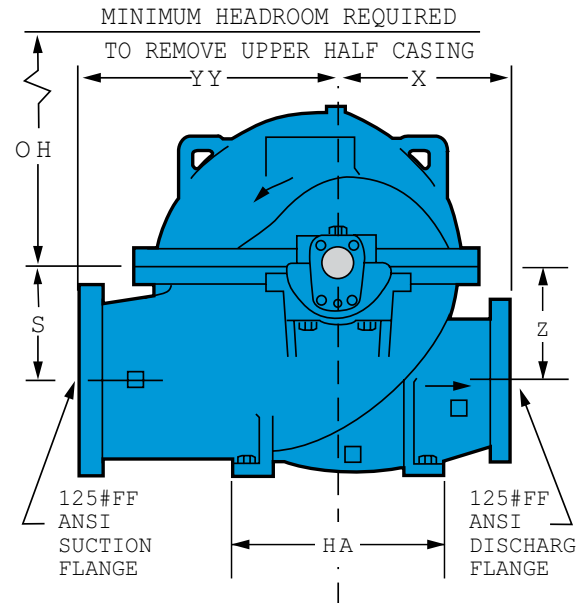
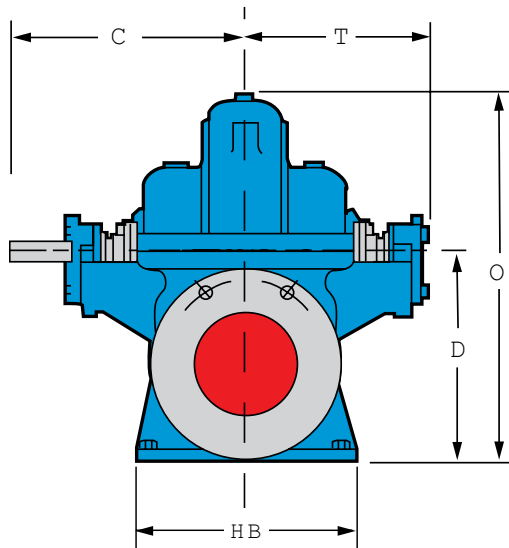

Frame Group	Pump Size	C	T	D	O	OH	S & Z	X	YY	HA	HB	Wt. Lbs. (kg)
S	2x3-11				18.38 (467)	12.38 (314)	7.25 (184)	7.50 (190)	9.00 (229)			330 (150)
	3x4-10				18.91 (480)	12.75 (324)	7.00 (178)	9.00 (229)	10.50 (267)			333 (151)
	4x6-9	14.62 (371)	11.76 (299)	11.50 (292)	17.88 (454)	10.88 (276)	6.00 (152)	8.50 (216)	10.00 (254)	12.00 (305)	12.50 (318)	334 (152)
	4x6-11/H				19.22 (488)	13.25 (336)	6.00 (152)	10.50 (267)	12.38 (314)			410 (186)
	4x6-13/H				20.59 (523)	15.88 (403)	6.00 (152)	11.00 (279)	13.25 (336)			472 (215)
M	4x6-15				25.88 (657)	17.38 (441)	9.50 (241)	10.00 (254)	14.50 (368)			637 (290)
	6x8-11				26.44 (672)	16.00 (406)	9.00 (229)	12.00 (305)	14.50 (368)			692 (315)
	6x8-14/H				25.75 (654)	16.75 (425)	9.00 (229)	13.00 (330)	15.50 (394)			665 (302)
	6x8-17	18.00 (457)	13.88 (353)	16.00 (406)	27.88 (708)	20.62 (524)	9.00 (229)	14.25 (362)	15.75 (400)	16.00 (406)	16.75 (425)	885 (402)
	8x10-11				25.50 (648)	15.25 (391)	9.00 (229)	13.25 (336)	17.00 (432)			737 (335)
	8x10-12				27.31 (694)	17.38 (441)	8.75 (222)	13.00 (330)	19.50 (495)			858 (398)
L	8x10-14				28.50 (724)	19.50 (495)	8.75 (222)	13.88 (352)	19.50 (495)			996 (453)
	6x8-22				40.50 (1029)	22.50 (572)	13.50 (343)	20.50 (520)	22.00 (559)			1495 (680)
	6x10-17				33.88 (860)	20.62 (524)	11.00 (279)	16.50 (419)	20.00 (508)			1015 (461)
	8x10-17/H				34.06 (865)	20.88 (530)	10.00 (254)	16.50 (419)	20.00 (559)			1286 (585)
	8x10-21	21.00 (533)	16.28 (414)	22.00 (559)	36.31 (922)	24.88 (632)	13.00 (330)	17.00 (432)	20.30 (521)	22.50 (572)	18.00 (457)	1520 (691)
	10x12-12				34.88 (886)	19.12 (486)	11.00 (279)	14.00 (356)	21.00 (533)			1229 (559)
XL	10x12-14				34.00 (864)	19.25 (489)	11.00 (279)	16.75 (426)	21.00 (533)			1410 (641)
	10x12-17				37.50 (952)	30.75 (781)	11.50 (292)	17.62 (448)	22.50 (572)			1709 (777)
	10x12-12 H				39.50 (1003)	21.75 (552)	13.00 (330)	15.00 (381)	22.00 (559)			2168 (985)
XL	10x12-15	23.19 (589)	17.64 (448)	24.00 (610)	38.00 (965)	21.50 (533)	13.00 (330)	16.00 (406)	24.00 (610)	22.50 (572)	27.00 (686)	1720 (782)
	12x14-15				36.50 (927)	21.75 (552)	13.00 (330)	18.00 (457)	25.00 (635)			2500 (1136)

All dimensions in inches and (mm). Not to be used for construction. Sizes 2x3-11, 4x6-11/H, 3x4-10, 8x10-21 & 6x8-22 are furnished with 250# FF discharge flange as standard. Standard rotation is right hand (CW). Optional rotation is left hand (CCW). Steel casings will have 150#RF or 300#RF flanges.

3400

Standard Design Features for a Wide Range of

RENEWABLE CASING WEAR RINGS

Eliminate casing wear and permit easy maintenance of proper running clearances for maximum efficiency operation. Positively locked in place in the lower casing half to prevent rotation during pump operation.

HEAVY DUTY SHAFTS

Designed for minimum deflection in the toughest services means excellent shaft seal and bearing life. Renewable shaft sleeves are available in a variety of materials (including hardened metals and hard metal coated) to protect shaft from pumpage.

DOUBLE SUCTION IMPELLERS

Minimizes axial thrust for longer bearing life. Polished waterways and fully machined exterior surfaces assure highly efficient performance. Dynamically balanced as standard for smooth operation.

HEAVY DUTY CASINGS

Rugged foot-mounted design to resist external forces and vibration. Casings designed to withstand high working pressures with minimum distortion and are 100% hydrostatically tested per Hydraulic Institute standards. Suction and discharge connections are in the lower half casing, allowing removal of upper half casing for inspection or removal of complete rotating element without disturbing piping or driver. (Bottom suction casings available on some 3498 sizes.)

BALANCED DESIGN

Dual volute casing design (not available on all sizes). Ideal when pumps must periodically operate at capacities above or below design capacity or at interrupted high head. Combined with double suction impeller for axial balance, the 3400 series is designed for high reliability and low maintenance.

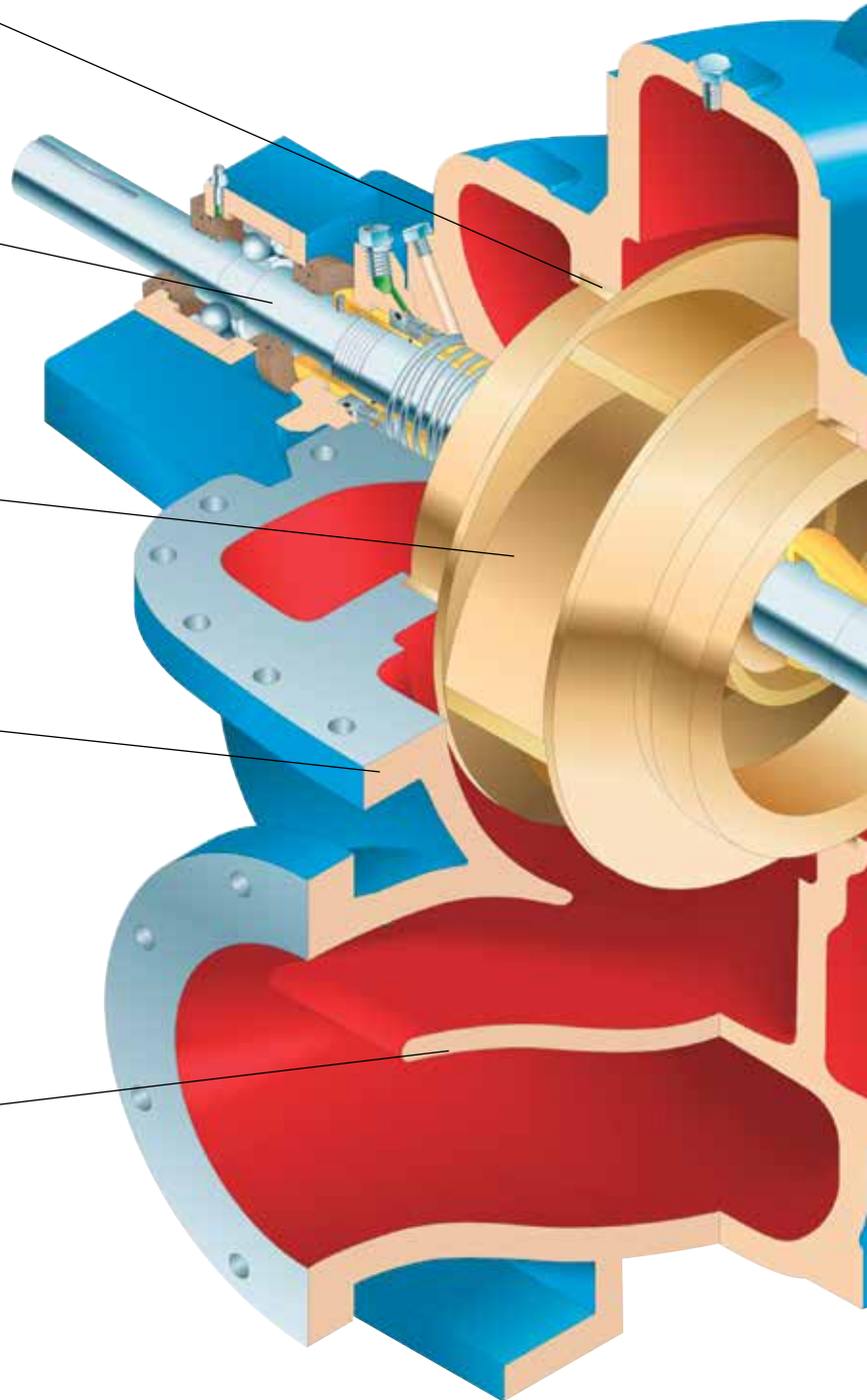

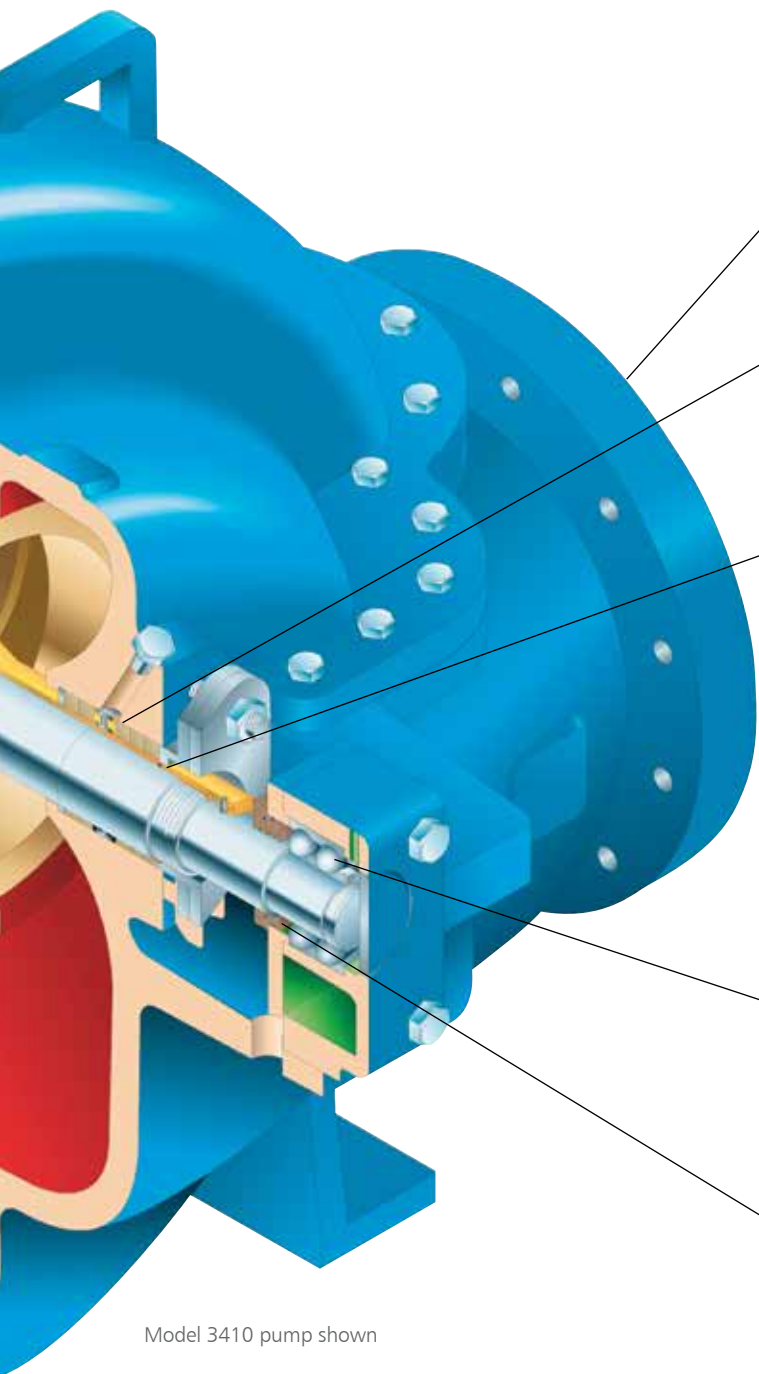

Model 3410 pump shown

LARGE INLET AREAS

Reduce NPSH requirements and ensure smooth, quiet flow to the impeller.

STUFFING BOX

Packing is standard on 3400 series product. A wide variety of mechanical seals, including cartridge and split type, are also available to suit the application.

POSITIVE LIQUID SEALING

Shaft is positively sealed from pumpage between impeller and sleeves, as well as between sleeves and sleeve nuts standard on all 3400 series pumps.

RENEWABLE IMPELLER WEAR RINGS

Positively locked on impeller hubs permit easy renewal of running clearance and protect impeller hubs from wear. Standard on large and extra large capacity models (3420 & 3498). Optional on all others.

DOUBLE ROW THRUST BEARING

Double row thrust bearing for high axial thrust capability is standard on all 3400 series pumps. Locked-on shaft in bearing housing positively positions rotating element and easily carries any residual axial thrust.

LABYRINTH BEARING PROTECTION

Standard on all 3400 series pumps. Significantly reduces the chance for bearing contamination and greatly improves mean time between failure.

3400

Medium Capacity

Model 3409

- Horizontal and vertical mounting
- Grease or ring oil lubricated bearings
- INPRO VBX labyrinth bearing isolators standard
- High pressure casings available
- Dual volute casings standard on all sizes
- Packing or mechanical seals available, (including cartridge and split type seals)
- Alloy constructions not shown below are also available

Materials of Construction

Part Description	Bronze Fitted	All Iron	316 SS Fitted	All 316 SS
Casing		Cast Iron ¹		316 SS
Impeller	Bronze	Cast Iron		316 SS
Lantern Ring		PTFE		
Packing		Graphite Impregnated Yarn		
Packing Gland	Bronze	Cast Iron		316 SS
Mechanical Seal Gland		Cast Iron		316 SS
Shaft		Carbon Steel ²		
Shaft Sleeve Nut	Bronze	Cast Iron		Nitronic 60
Shaft Sleeve ³	Bronze	Cast Iron		316 SS
Casing Wear Ring ³	Bronze	Cast Iron		Nitronic 60
Bearing Housing		Cast Iron		
Impeller Wear Ring (optional) ³	Bronze	Cast Iron		316 SS
Bearings		Steel (Anti-Friction)		

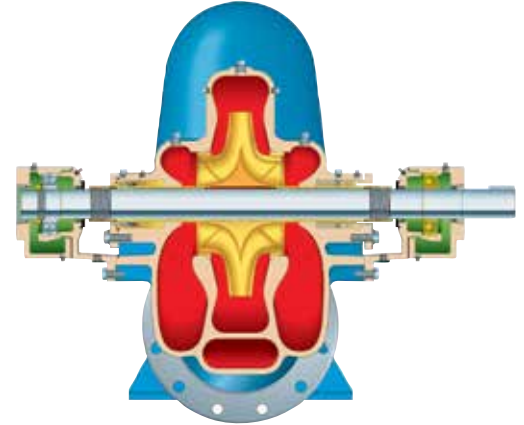

¹ Size 8x12-27 casing material is ductile iron as standard.
² Shaft material will be 17-4 PH for certain size & speed combinations.
³ Also available in hardened/hard metal coated materials.

Dimensions

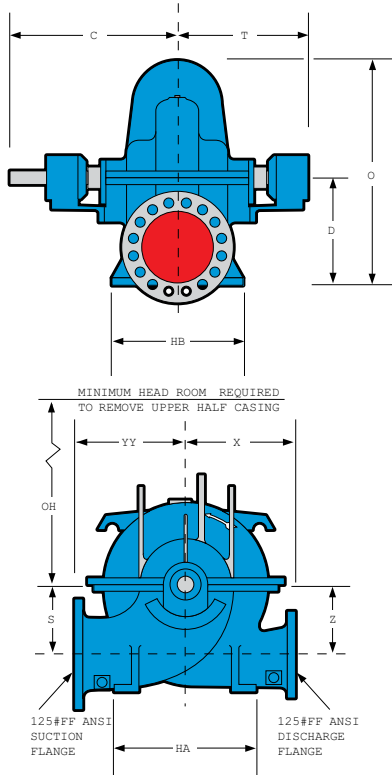

Frame Group	Pump Size	C	T	D	O	OH	S & Z	X	YY	HA	HB	Weight Lbs. (kg)
S	6x10-22				37.9 (962)	30.4 (772)		19 (483)	20			1545 (701)
	8x12-21	28.3 (718)	21.8 (552)	19 (483)		30.8 (782)	12 (305)			24 (610)	18 (457)	1905 (864)
	8x12-22M				38.9 (988)	30.4 (772)		21 (533)	21 (533)			1920 (871)
	8x12-22L					31.4 (798)						1930 (875)
M	8x12-27				43.9 (1115)	36.4 (924)	14.2 (360)	23 (584)	24 (610)			2940 (1334)
	10x14-20S			21 (533)								2000 (907)
	10x14-20L	30.5 (775)	23.8 (603)		42.8 (1086)	31.7 (804)	13 (330)	19 (483)	21 (533)	24 (610)	24 (610)	2050 (930)
	12x16-23			23 (584)	48.9 (1242)	37.4 (949)		25 (635)	25 (635)			2600 (1179)
	14x16-17			23.5 (597)	46.3 (1181)	31.8 (806)	14 (356)	18 (457)	24 (610)			2860 (1297)
L	14x18-23	31.6 (802)	24.8 (629)	24 (610)	47.6 (1210)	35.1 (892)	14 (356)	27 (686)	27 (686)	27 (711)	26 (660)	2940 (1334)
	14x18-28			26 (660)	56.8 (1441)	44.7 (1135)	16 (406)	28 (711)	28 (711)			3255 (1476)

All dimensions in inches and (mm). Not to be used for construction. Sizes 2x3-11, 4x6-11/H, 3x4-10, 8x10-21 & 6x8-22 are furnished with 250# FF discharge flange as standard. Standard rotation is right hand (CW). Optional rotation is left hand (CCW). Steel casings will have 150#RF or 300#RF flanges.

Large Capacity

Model 3420

- Sleeve bearings available
- Grease or ring oil lubricated bearings
- Packing or mechanical seals available (including cartridge and split type seals)
- Dual volute casings standard on all sizes
- Labyrinth bearing protection standard
- Alloy constructions not shown below are also available
- Shaft sleeve nuts threaded against rotation a standard
- Vertical mounting available on some sizes
- Impeller wear rings standard

Materials of Construction

Part Description	Bronze Fitted	All Iron	316 SS Fitted	All 316 SS
Casing		Cast Iron		316 SS
Impeller	Bronze	Cast Iron		316 SS
Lantern Ring		PTFE		
Packing		Graphite Impregnated Yarn		
Packing Gland	Bronze	Cast Iron		316 SS
Mechanical Seal Gland		Cast Iron		316 SS
Shaft		Carbon Steel		
Shaft Sleeve Nut	Bronze	Cast Iron		316 SS
Shaft Sleeve ¹	Bronze	Cast Iron		316 SS
Casing Wear Ring ¹	Bronze	Cast Iron		316 SS
Bearing Housings		Cast Iron		
Impeller Wear Ring ¹	Bronze	Cast Iron		316 SS
Bearings		Steel (Anti-Friction)		

¹ Also available in hardened/hard metal coated materials.

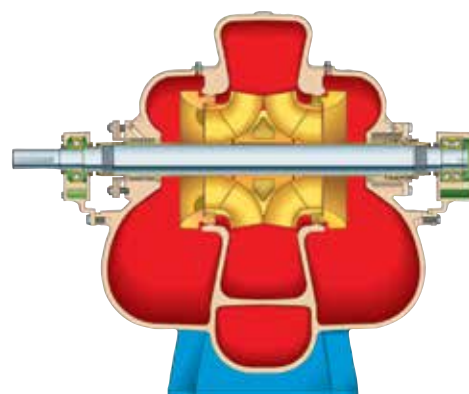

Dimensions

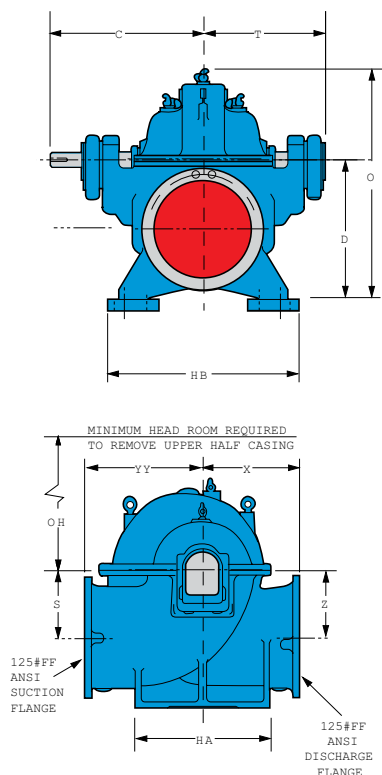

Pump Size	C	T	D	O	OH	S & Z	X	YY	HA	HB	Weight Lbs. (kg)
12x14-15	33.0 (838)	26.7 (679)	26.4 (670)	42.3 (1073)	25.0 (635)	14.8 (375)	17.8 (451)	24.8 (629)	33.0 (838)	24.0 (610)	2600 (1179)
16x18-17/H	33.0 (838)	26.7 (679)	33.5 (851)	54.3 (1378)	31.0 (787)	18.8 (476)	20.9 (530)	31.5 (800)	33.0 (838)	24.0 (610)	3500 (1588)
16x18-30/G/H	44.4 (1127)	36.6 (930)	36.0 (914)	62.3 (1581)	41.3 (1048)	22.5 (572)	28.0 (711)	34.0 (864)	46.0 (1168)	47.0 (1194)	7060 (3202)
18x20-24/G	39.1 (992)	33.5 (851)	35.5 (902)	59.9 (1521)	38.0 (965)	19.5 (495)	20.6 (524)	38.9 (989)	49.0 (1245)	46.0 (1168)	5650 (2563)
18x20-30	44.4 (1127)	36.6 (930)	37.5 (953)	64.3 (1632)	41.8 (1060)	22.8 (578)	29.0 (737)	35.0 (889)	48.0 (1219)	47.0 (1194)	7500 (3402)
20x24-24	44.4 (1127)	36.6 (930)	38.0 (965)	63.8 (1619)	37.8 (959)	20.5 (521)	26.6 (675)	34.0 (864)	42.0 (1067)	47.0 (1194)	7200 (3266)
20x24-28/G/H	37.9 (962)	39.5 (1003)	42.1 (1070)	70.3 (1784)	44.0 (1118)	23.1 (587)	24.5 (622)	46.2 (1173)	56.0 (1422)	54.0 (1372)	8650 (3924)
20x24-30	46.0 (1168)	36.6 (930)	40.5 (1029)	68.0 (1727)	42.5 (1080)	23.5 (597)	29.5 (749)	36.0 (914)	50.0 (1270)	47.0 (1194)	8000 (3629)
24x30-32/G/H/N	44.4 (1127)	39.7 (1008)	44.0 (1118)	74.1 (1883)	45.0 (1143)	22.5 (572)	36.0 (914)	50.0 (1270)	56.0 (1422)	51.0 (1295)	11,500 (5216)
30x30-31/G	50.0 (1270)	43.5 (1104)	53.3 (1353)	86.4 (2196)	50.7 (1287)	33.4 (848)	40.0 (1016)	52.0 (1321)	63.4 (1610)	53.4 (1356)	16,200 (7348)
30x30-38/G	53.0 (1346)	43.7 (1110)	53.3 (1353)	87.5 (2223)	53.3 (1353)	30.8 (781)	36.5 (927)	54.5 (1384)	63.4 (1610)	53.4 (1356)	15,400 (6985)
30x36-42/G/H	60.8 (1545)	47.6 (1209)	58.0 (1473)	97.5 (2477)	62.0 (1575)	34.0 (864)	36.0 (914)	54.5 (1384)	78.0 (1981)	76.0 (1930)	25,250 (11,453)

All dimensions in inches (mm) and are not to be used for construction or installation purposes. Standard rotation is right hand (CW). Optional rotation is left hand (CCW). Steel casings will have 150#RF flanges.

3400

Extra Large Capacity

Model 3498

- Sleeve bearings available
- Grease or ring oil lubricated bearings
- Packing or mechanical seals available (including cartridge and split type seals)
- Dual volute casings standard on some sizes.
- Bottom suction available on some sizes
- Vertical mounting available on some sizes
- Alloy constructions not shown below are also available
- Shaft sleeve nuts threaded against rotation as standard
- Impeller wear rings standard

Materials of Construction

Part Description	Bronze Fitted	All Iron	316 SS Fitted	All 316 SS
Casing		Cast Iron		316 SS
Impeller	Bronze	Cast Iron		316 SS
Lantern Ring		PTFE		
Packing		Graphite Impregnated Yarn		
Packing Gland	Bronze	Cast Iron		316 SS
Mechanical Seal Gland		Cast Iron		316 SS
Shaft		Carbon Steel		
Shaft Sleeve Nut	Bronze	Cast Iron		316 SS
Shaft Sleeve'	Bronze	Cast Iron		316 SS
Casing Wear Ring'	Bronze	Cast Iron		316 SS
Bearing Housings		Cast Iron		
Impeller Wear Ring'	Bronze	Cast Iron		316 SS
Bearings		Steel (Anti-Friction)		

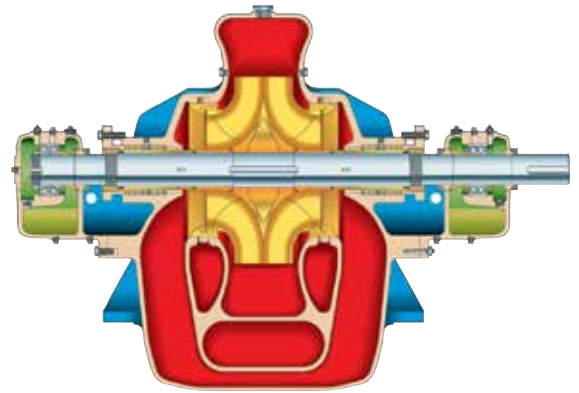

¹ Also available in hardened/hard metal coated materials.

Dimensions

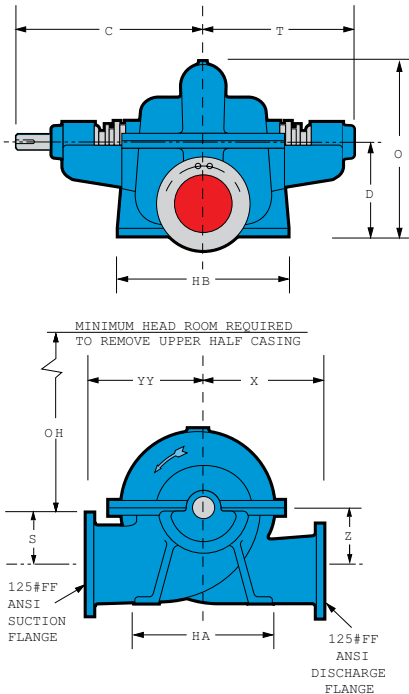

Pump Size	C	T	D	O	OH	S	Z	X	YY	HA	HB	Weight Lbs. (kg)
12x16-28	39.0 (991)	49.0 (1245)	7.0 (178)	23.0 (584)	29.5 (749)	19.0 (483)	19.0 (483)	36.0 (914)	34.0 (864)	31.0 (787)	44.0 (1118)	5900 (2676)
12x18-34*	42.0 (1067)	35.0 (889)	29.0 (737)	54.0 (1372)	42.3 (1073)	22.5 (572)	24.0 (610)	30.0 (762)	38.0 (965)	51.0 (1295)	44.0 (1118)	6600 (2994)
16x18-18*	33.0 (838)	31.0 (787)	23.0 (584)	38.0 (965)	23.9 (606)	13.0 (330)	14.0 (356)	17.0 (432)	24.0 (610)	24.0 (610)	38.0 (965)	3000 (1361)
16x18-28*	40.0 (1016)	36.0 (914)	29.0 (737)	52.0 (1321)	36.7 (931)	23.0 (584)	22.0 (559)	34.0 (864)	35.0 (889)	51.0 (1295)	42.0 (1067)	5000 (2268)
16x20-24	45.0 (1143)	35.5 (902)	28.0 (711)	49.0 (1245)	33.5 (851)	17.0 (432)	19.5 (495)	24.0 (610)	30.0 (762)	30.0 (762)	42.0 (1067)	4600 (2087)
18x20-24*	46.0 (1168)	36.4 (925)	26.0 (660)	47.0 (1194)	33.3 (845)	18.0 (457)	19.0 (483)	21.0 (533)	32.0 (813)	35.0 (889)	51.0 (1295)	4380 (1987)
20x20-18	36.0 (914)	31.0 (787)	29.0 (737)	47.0 (1194)	26.5 (673)	18.0 (457)	18.0 (457)	22.0 (559)	29.0 (737)	31.0 (787)	40.0 (1016)	3480 (1579)
16x24-24	40.0 (1016)	33.0 (838)	20.0 (508)	41.0 (1041)	33.5 (851)	20.0 (508)	20.0 (508)	22.0 (559)	34.0 (864)	36.0 (914)	42.0 (1067)	5700 (2585)
16x24-38*	49.0 (1245)	41.0 (1041)	32.0 (813)	59.5 (1511)	46.5 (1181)	26.0 (660)	26.0 (660)	48.0 (1219)	42.0 (1067)	53.0 (1346)	50.0 (1270)	11,000 (4990)
18x24-34*	45.0 (1143)	38.0 (965)	24.0 (610)	48.0 (1219)	40.5 (1029)	24.0 (610)	21.0 (533)	36.0 (914)	39.0 (991)	56.0 (1422)	50.0 (1270)	6980 (3166)
20x24-20	40.0 (1016)	38.0 (965)	34.0 (864)	55.0 (1397)	30.7 (780)	21.0 (533)	21.0 (533)	25.0 (635)	33.0 (838)	40.0 (1016)	46.0 (1168)	5500 (2495)
20x24-20S/L	34.0 (864)	28.0 (711)	20.0 (508)	40.0 (1016)	29.6 (752)	20.0 (508)	20.0 (508)	20.0 (508)	42.0 (1067)	38.0 (965)	48.0 (1219)	5100 (2313)
24x24-26*	40.0 (1016)	36.0 (914)	35.0 (889)	56.0 (1422)	33.8 (857)	21.0 (533)	21.0 (533)	26.0 (660)	35.0 (889)	40.0 (1016)	54.0 (1372)	6650 (3016)
20x30-28	44.0 (1118)	36.0 (914)	23.0 (584)	48.0 (1219)	39.0 (991)	23.0 (584)	23.0 (584)	27.0 (686)	40.0 (1016)	42.0 (1067)	48.0 (1219)	6750 (3062)
20x30-34*	51.0 (1295)	40.0 (1016)	30.3 (768)	56.0 (1422)	43.0 (1092)	22.5 (572)	22.5 (572)	34.3 (870)	42.0 (1067)	44.0 (1118)	60.0 (1524)	12,200 (5534)
20x30-40*	52.0 (1321)	41.0 (1041)	34.0 (864)	64.0 (1626)	49.5 (1257)	26.3 (667)	26.3 (667)	33.0 (838)	46.0 (1168)	44.0 (1118)	60.0 (1524)	13,500 (6123)
24x30-30*	51.0 (1295)	55.0 (1397)	31.0 (787)	59.0 (1499)	43.4 (1102)	19.0 (483)	22.0 (559)	30.0 (762)	45.0 (1143)	52.0 (1321)	56.0 (1422)	9500 (4309)
24x36-40*	62.0 (1575)	49.0 (1245)	34.0 (864)	68.0 (1727)	54.0 (1372)	29.0 (737)	29.0 (737)	63.0 (1600)	50.0 (1270)	72.0 (1829)	65.0 (1651)	17,500 (7938)
24x36-48*	58.0 (1473)	56.0 (1422)	40.0 (1016)	82.0 (2083)	66.0 (1676)	40.0 (1016)	39.0 (991)	46.0 (1168)	66.0 (1676)	92.0 (2337)	66.0 (1676)	26,200 (11,884)
30x36-34*	56.0 (1422)	49.0 (1245)	36.0 (914)	66.0 (1676)	47.5 (1207)	24.0 (610)	27.0 (686)	33.0 (838)	51.0 (1295)	57.0 (1448)	78.0 (1981)	13,000 (5897)
30x36-35*	62.0 (1575)	50.0 (1270)	36.0 (914)	66.0 (1676)	47.5 (1207)	24.0 (610)	27.0 (686)	33.0 (838)	51.0 (1295)	57.0 (1448)	78.0 (1981)	15,000 (6804)
30x36-36	58.0 (1473)	49.0 (1245)	48.0 (1219)	79.0 (2007)	49.3 (1251)	27.0 (686)	30.0 (762)	38.0 (965)	50.0 (1270)	51.0 (1295)	72.0 (1829)	18,500 (8391)
30x42-46	72.0 (1829)	61.0 (1549)	48.0 (1219)	86.0 (2184)	60.5 (1537)	31.0 (787)	36.0 (914)	84.0 (2134)	54.0 (1372)	75.0 (1905)	96.0 (2438)	22,500 (10,206)
30x42-48*	66.0 (1676)	63.0 (1600)	42.0 (1067)	81.0 (2057)	63.0 (1600)	38.0 (965)	38.0 (965)	50.0 (1270)	72.0 (1829)	90.0 (2286)	79.0 (2007)	24,400 (11,068)
30x42-72*	69.0 (1753)	67.0 (1702)	54.0 (1372)	106.0 (2692)	87.5 (2223)	51.0 (1295)	51.0 (1295)	78.0 (1981)	84.0 (2134)	126.0 (3200)	84.0 (2134)	34,200 (15,513)
36x42-40*	62.0 (1575)	51.0 (1295)	45.0 (1143)	81.0 (2057)	55.5 (1410)	29.0 (737)	30.0 (762)	39.0 (991)	57.0 (1448)	69.0 (1753)	92.0 (2337)	23,300 (10,569)
42x48-48*	69.0 (1753)	58.0 (1473)	54.0 (1372)	97.0 (2464)	67.4 (1711)	33.0 (838)	37.0 (940)	48.0 (1219)	69.0 (1753)	76.0 (1930)	102.0 (2591)	34,000 (15,422)
48x54-58	83.0 (2108)	72.0 (1829)	60.0 (1524)	113.0 (2870)	82.2 (2088)	44.0 (1118)	44.0 (1118)	45.0 (1143)	84.0 (2134)	95.0 (2413)	124.0 (3150)	44,000 (19,958)
48x54-64	69.0 (1753)	60.0 (1524)	45.0 (1143)	90.0 (2286)	76.8 (1951)	45.0 (1143)	45.0 (1143)	50.0 (1270)	86.0 (2184)	102.0 (2591)	88.0 (2235)	50,400 (22,861)
54" to 78" Suction												CONSULT FACTORY

All dimensions in inches (mm) and are not to be used for construction or installation purposes. Standard rotation is right hand (CW). Optimal rotation is left hand (CCW). Side suction casing illustrated. Asterisks indicate sizes available with bottom suction casing. Steel casings will have 150#RF flanges.

