

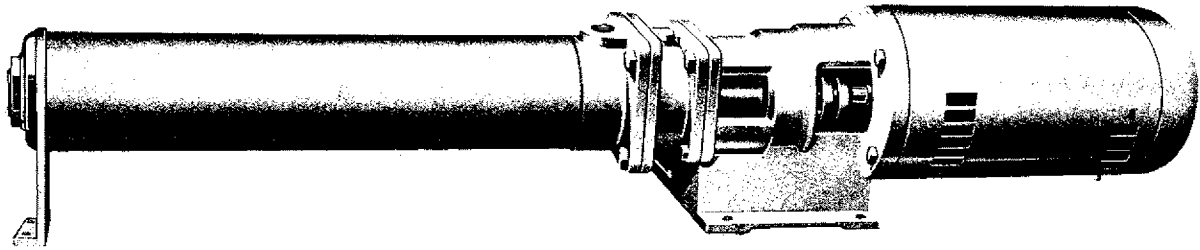

GOULDS PUMPS

Installation, Operation and Maintenance Instructions



MODEL 3934



ITT

IMPORTANT SAFETY NOTICE

To: Our Valued Customers

User safety is a major focus in the design of our products. Following the precautions outlined in this manual will minimize your risk of injury.

ITT Goulds pumps will provide safe, trouble-free service when properly installed, maintained, and operated.

Safe installation, operation, and maintenance of ITT Goulds Pumps equipment are an essential end user responsibility. This *Pump Safety Manual* identifies specific safety risks that must be considered at all times during product life. Understanding and adhering to these safety warnings is mandatory to ensure personnel, property, and/or the environment will not be harmed. Adherence to these warnings alone, however, is not sufficient — it is anticipated that the end user will also comply with industry and corporate safety standards. Identifying and eliminating unsafe installation, operating and maintenance practices is the responsibility of all individuals involved in the installation, operation, and maintenance of industrial equipment.

Please take the time to review and understand the safe installation, operation, and maintenance guidelines outlined in this Pump Safety Manual and the Instruction, Operation, and Maintenance (IOM) manual. Current manuals are available at www.gouldspumps.com/literature_ioms.html or by contacting your nearest Goulds Pumps sales representative.

These manuals must be read and understood before installation and start-up.

For additional information, contact your nearest Goulds Pumps sales representative or visit our Web site at www.gouldspumps.com.

SAFETY WARNINGS

Specific to pumping equipment, significant risks bear reinforcement above and beyond normal safety precautions.

 **WARNING**

A pump is a pressure vessel with rotating parts that can be hazardous. Any pressure vessel can explode, rupture, or discharge its contents if sufficiently over pressurized causing death, personal injury, property damage, and/or damage to the environment. All necessary measures must be taken to ensure over pressurization does not occur.

 **WARNING**

Operation of any pumping system with a blocked suction and discharge must be avoided in all cases. Operation, even for a brief period under these conditions, can cause superheating of enclosed pumpage and result in a violent explosion. All necessary measures must be taken by the end user to ensure this condition is avoided.

 **WARNING**

The pump may handle hazardous and/or toxic fluids. Care must be taken to identify the contents of the pump and eliminate the possibility of exposure, particularly if hazardous and/or toxic. Potential hazards include, but are not limited to, high temperature, flammable, acidic, caustic, explosive, and other risks.

 **WARNING**

Pumping equipment Instruction, Operation, and Maintenance manuals clearly identify accepted methods for disassembling pumping units. These methods must be adhered to. Specifically, applying heat to impellers and/or impeller retaining devices to aid in their removal is strictly forbidden. Trapped liquid can rapidly expand and result in a violent explosion and injury.

ITT Goulds Pumps will not accept responsibility for physical injury, damage, or delays caused by a failure to observe the instructions for installation, operation, and maintenance contained in this Pump Safety Manual or the current IOM available at www.gouldspumps.com/literature.

SAFETY

DEFINITIONS

Throughout this manual the words **WARNING**, **CAUTION**, **ELECTRICAL**, and **ATEX** are used to indicate where special operator attention is required.

Observe all Cautions and Warnings highlighted in this Pump Safety Manual and the IOM provided with your equipment.



WARNING

Indicates a hazardous situation which, if not avoided, could result in death or serious injury.

Example: Pump shall never be operated without coupling guard installed correctly.



CAUTION

Indicates a hazardous situation which, if not avoided, could result in minor or moderate injury.

Example: Throttling flow from the suction side may cause cavitation and pump damage.



ELECTRICAL HAZARD

Indicates the possibility of electrical risks if directions are not followed.

Example: Lock out driver power to prevent electric shock, accidental start-up, and physical injury.



When installed in potentially explosive atmospheres, the instructions that follow the Ex symbol must be followed. Personal injury and/or equipment damage may occur if these instructions are not followed. If there is any question regarding these requirements or if the equipment is to be modified, please contact an ITT Goulds Pumps representative before proceeding.





Example:  Improper impeller adjustment could cause contact between the rotating and stationary parts, resulting in a spark and heat generation.

General precautions



















WARNING:

A pump is a pressure vessel with rotating parts that can be hazardous. Hazardous fluids may be contained by the pump including high temperature, flammable, acidic, caustic, explosive, and other risks. Operators and maintenance personnel must realize this and follow safety measures. Personal injuries will result if procedures outlined in this manual are not followed. ITT Goulds Pumps will not accept responsibility for physical injury, damage or delays caused by a failure to observe the instructions in this manual and the IOM provided with your equipment.

WARNING		NEVER APPLY HEAT TO REMOVE IMPELLER. It may explode due to trapped liquid.
WARNING		NEVER use heat to disassemble pump due to risk of explosion from tapped liquid.
WARNING		NEVER operate pump without coupling guard correctly installed.
WARNING		NEVER run pump below recommended minimum flow when dry, or without prime.
WARNING		ALWAYS lock out power to the driver before performing pump maintenance.
WARNING		NEVER operate pump without safety devices installed.
WARNING		NEVER operate pump with discharge valve closed.
WARNING		NEVER operate pump with suction valve closed.
WARNING		DO NOT change service application without approval of an authorized ITT Goulds Pumps representative.
WARNING		<p>Safety Apparel:</p> <ul style="list-style-type: none"> • Insulated work gloves when handling hot bearings or using bearing heater • Heavy work gloves when handling parts with sharp edges, especially impellers • Safety glasses (with side shields) for eye protection • Steel-toed shoes for foot protection when handling parts, heavy tools, etc. • Other personal protective equipment to protect against hazardous/toxic fluids
WARNING		Receiving:

4 General precautions

		Assembled pumping units and their components are heavy. Failure to properly lift and support equipment can result in serious physical injury and/or equipment damage. Lift equipment only at specifically identified lifting points or as instructed in the current IOM. Current manuals are available at www.gouldspumps.com/literature_ioms.html or from your local ITT Goulds Pumps sales representative. Note: Lifting devices (eyebolts, slings, spreaders, etc.) must be rated, selected, and used for the entire load being lifted.
WARNING		Alignment: Shaft alignment procedures must be followed to prevent catastrophic failure of drive components or unintended contact of rotating parts. Follow coupling manufacturer's coupling installation and operation procedures.
WARNING		Before beginning any alignment procedure, make sure driver power is locked out. Failure to lock out driver power will result in serious physical injury.
CAUTION		Piping: Never draw piping into place by forcing at the flanged connections of the pump. This may impose dangerous strains on the unit and cause misalignment between pump and driver. Pipe strain will adversely effect the operation of the pump resulting in physical injury and damage to the equipment.
WARNING		Flanged Connections: Use only fasteners of the proper size and material.
WARNING		Replace all corroded fasteners.
WARNING		Ensure all fasteners are properly tightened and there are no missing fasteners.
WARNING		Startup and Operation: When installing in a potentially explosive environment, please ensure that the motor is properly certified.
WARNING		Operating pump in reverse rotation may result in contact of metal parts, heat generation, and breach of containment.
WARNING		Lock out driver power to prevent accidental start-up and physical injury.
WARNING		The impeller clearance setting procedure must be followed. Improperly setting the clearance or not following any of the proper procedures can result in sparks, unexpected heat generation and equipment damage.
WARNING		If using a cartridge mechanical seal, the centering clips must be installed and set screws loosened prior to setting impeller clearance. Failure to do so could result in sparks, heat generation, and mechanical seal damage.
WARNING		The coupling used in an ATEX classified environment must be properly certified and must be constructed from a non-sparking material.
WARNING		Never operate a pump without coupling guard properly installed. Personal injury will occur if pump is run without coupling guard.

WARNING		Make sure to properly lubricate the bearings. Failure to do so may result in excess heat generation, sparks, and / or premature failure.
CAUTION		The mechanical seal used in an ATEX classified environment must be properly certified. Prior to start up, ensure all points of potential leakage of process fluid to the work environment are closed.
CAUTION		Never operate the pump without liquid supplied to mechanical seal. Running a mechanical seal dry, even for a few seconds, can cause seal damage and must be avoided. Physical injury can occur if mechanical seal fails.
WARNING		Never attempt to replace packing until the driver is properly locked out and the coupling spacer is removed.
WARNING		Dynamic seals are not allowed in an ATEX classified environment.
WARNING		DO NOT operate pump below minimum rated flows or with suction and/or discharge valve closed. These conditions may create an explosive hazard due to vaporization of pumpage and can quickly lead to pump failure and physical injury.
WARNING		Ensure pump is isolated from system and pressure is relieved before disassembling pump, removing plugs, opening vent or drain valves, or disconnecting piping.
WARNING		Shutdown, Disassembly, and Reassembly: Pump components can be heavy. Proper methods of lifting must be employed to avoid physical injury and/or equipment damage. Steel toed shoes must be worn at all times.
WARNING		The pump may handle hazardous and/or toxic fluids. Observe proper decontamination procedures. Proper personal protective equipment should be worn. Precautions must be taken to prevent physical injury. Pumpage must be handled and disposed of in conformance with applicable environmental regulations.
WARNING		Operator must be aware of pumpage and safety precautions to prevent physical injury.
WARNING		Lock out driver power to prevent accidental startup and physical injury.
CAUTION		Allow all system and pump components to cool before handling them to prevent physical injury.
CAUTION		If pump is a Model NM3171, NM3196, 3198, 3298, V3298, SP3298, 4150, 4550, or 3107, there may be a risk of static electric discharge from plastic parts that are not properly grounded. If pumped fluid is non-conductive, pump should be drained and flushed with a conductive fluid under conditions that will not allow for a spark to be released to the atmosphere.
WARNING		Never apply heat to remove an impeller. The use of heat may cause an explosion due to trapped fluid, resulting in severe physical injury and property damage.
CAUTION		Wear heavy work gloves when handling impellers as sharp edges may cause physical injury.
CAUTION		Wear insulated gloves when using a bearing heater. Bearings will get hot and can cause physical injury.

4 General precautions

WARNING		<p>Noise:</p> <p>Sound pressure levels may exceed 80 dbA in operating process plants. Clear visual warnings or other indicators should be available to those entering an area with unsafe noise levels. Personnel should wear appropriate hearing protection when working on or around any equipment, including pumps. Consider limiting personnel's exposure time to noise or, where possible, enclosing equipment to reduce noise. Local law may provide specific guidance regarding exposure of personnel to noise and when noise exposure reduction is required.</p>
WARNING		<p>Temperature:</p> <p>Equipment and piping surfaces may exceed 130°F (54°C) in operating process plants. Clear visual warnings or other indicators should alert personnel to surfaces that may reach a potentially unsafe temperature. Do not touch hot surfaces. Allow pumps operating at a high temperature to cool sufficiently before performing maintenance. If touching a hot surface cannot be avoided, personnel should wear appropriate gloves, clothing, and other protective gear as necessary. Local law may provide specific guidance regarding exposure of personnel to unsafe temperatures.</p>
WARNING		<p>This product contains Carbon Black a chemical known to the State of California to cause cancer. For more information go to www.P65Warnings.ca.gov</p>

ATEX CONSIDERATIONS and INTENDED USE

Special care must be taken in potentially explosive environments to ensure that the equipment is properly maintained. This includes but is not limited to:

1. Monitoring the pump frame and liquid end temperature.
2. Maintaining proper bearing lubrication.
3. Ensuring that the pump is operated in the intended hydraulic range.

The ATEX conformance is only applicable when the pump unit is operated within its intended use. Operating, installing or maintaining the pump unit in any way that is not covered in the Instruction, Operation, and Maintenance manual (IOM) can cause serious personal injury or damage to the equipment. This includes any modification to the equipment or use of parts not provided by ITT Goulds Pumps. If there is any question regarding the intended use of the equipment, please contact an ITT Goulds representative before proceeding. Current IOMs are available at www.gouldspumps.com/literature_ioms.html or from your local ITT Goulds Pumps Sales representative.

All pumping unit (pump, seal, coupling, motor and pump accessories) certified for use in an ATEX classified environment, are identified by an ATEX tag secured to the pump or the baseplate on which it is mounted. A typical tag would look like this:



The CE and the Ex designate the ATEX compliance. The code directly below these symbols reads as follows:

- II = Group 2
- 2 = Category 2
- G/D = Gas and Dust present
- T4 = Temperature class, can be T1 to T6 (see Table 1)

Code	Max permissible surface temperature °F (°C)	Max permissible liquid temperature °F (°C)
T1	842 (450)	700 (372)
T2	572 (300)	530 (277)
T3	392 (200)	350 (177)
T4	275 (135)	235 (113)
T5	212 (100)	Option not available
T6	185 (85)	Option not available

The code classification marked on the equipment must be in accordance with the specified area where the equipment will be installed. If it is not, do not operate the equipment and contact your ITT Goulds Pumps sales representative before proceeding.

PARTS

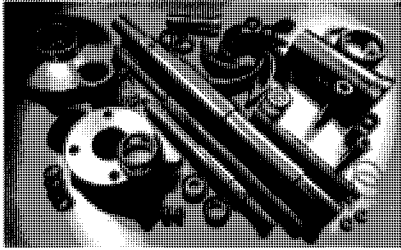

The use of genuine Goulds parts will provide the safest and most reliable operation of your pump. ITT Goulds Pumps ISO certification and quality control procedures ensure the parts are manufactured to the highest quality and safety levels.

Please contact your local Goulds representative for details on genuine Goulds parts.

FOREWORD

The design, material, and workmanship incorporated in the construction of Goulds Pumps makes them capable of giving long, trouble-free service. The life and satisfactory service of any mechanical unit, however, is enhanced and extended by correct application, proper installation, periodic inspection and careful maintenance. This instruction manual was prepared to assist operators in understanding the construction and the correct methods of installing, operating and maintaining these pumps.

Study thoroughly Sections I, II, III and IV and carefully follow the instructions for installation and operation. Sections V and VI are answers to trouble and maintenance questions. Keep this instruction manual handy for reference. Further information can be obtained by contacting the Engineering Application Division, Goulds Pumps, Inc., Seneca Falls, New York or your local branch office.

WARNING: Goulds Pumps, Inc. will not be liable for any damages or delay caused by failure to comply with the provisions of this instruction manual.

TABLE OF CONTENTS

SECTION I — INSTALLATION		PAGE	SECTION IV — OPERATION		PAGE
I-A.	Description of Units	1	IV-A.	Stuffing Box	15
I-B.	Storage, Uncrating & Handling	1	IV-B.	Operating at Reduced Capacities	15
I-C.	Location	1	IV-C.	Operating at Reduced Head	15
I-D.	Installation — "Close-Coupled" & "Vertical" Pumps ..	1	IV-D.	Operating with Surge Conditions in Line	15
I-E.	Installation — "Horizontal" Pumps	2	IV-E.	Operating under Freezing Conditions	15
I-F.	Alignment Procedures	3	SECTION V — TROUBLE CHECK LIST		
I-G.	Piping — General	5	V-A.	No Liquid Delivered	16
I-H.	Piping — Suction	6	V-B.	Not Enough Liquid Delivered	16
I-J.	Piping — Discharge	8	V-C.	Not Enough Pressure	16
I-K.	Connection of Piping	8	V-D.	Pump Works a While & Then Quits	16
I-L.	Rotation	8	V-E.	Pump Takes Too Much Power	16
I-M.	Connection of Coupling	8	V-F.	Pump Leaks Excessively at Stuffing Box	17
SECTION II — PREPARATION FOR OPERATION			V-G.	Pump is Noisy and Vibrates	17
II-A.	Pump Bearings	9	V-H.	High Bearing Temperature	17
II-B.	Driver Bearings & Coupling	9	SECTION VI — CARE AND MAINTENANCE OF BEARINGS		
II-C.	Stuffing Boxes	9	VI-A.	Bearing Temperatures	18
II-D.	Connection of Sealing Liquid or Grease Lubricator...	10	VI-B.	Bearing Inspection	18
II-E.	Connection of Cooling Water Piping	11	VI-C.	Cleaning of Bearings	18
II-F.	Connection of Drain Piping	11	VI-D.	Bearing Removal	18
II-G.	Connection of Equalizing Piping	11	VI-E.	Ball Bearing Installation	19
II-H.	Impeller Adjustment	11	SECTION VII — ORDERING OF SPARE PARTS		
SECTION III — STARTING PUMP			VII-A.	Spare Parts	20
III-A.	Checking for Free Turning	12	VII-B.	Instructions For Ordering Spare Parts	20
III-B.	Regulation of Cooling & Flushing Liquids	12	SECTION VIII — MAINTENANCE (Green Insert in Center)		
III-C.	Priming	12	VIII-A.	Lubrication	1A
III-D.	Initial Inspection After Starting	14	VIII-B.	Impeller Clearance Adjustment	1A
III-E.	Alignment — Final	14	VIII-C.	Disassembly of Pump	1A
III-F.	Doweling	14	VIII-D.	Sectional View and Parts List	2A
			VIII-E.	Inspection and Overhaul	2A
			VIII-F.	Reassembly	2A
			VIII-G.	Bearing and Seal Replacement	3A

NOTE: Refer to pages 6A & 7A (Green Center Section) for Changes and Additions

SEE GREEN CENTER SECTION FOR MAINTENANCE INSTRUCTIONS

SECTION I — INSTALLATION

I - A. DESCRIPTION OF UNITS

Reference is made to several different types of pumps in the following text. To enable the reader to associate these terms to his particular unit, photographs of typical units with an identifying description are shown below.

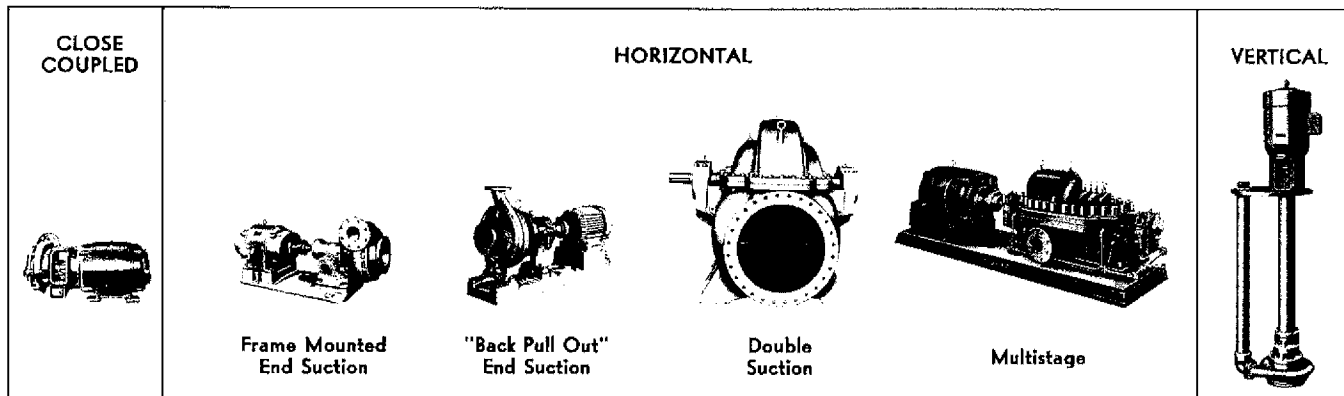

I - B. STORAGE, UNCRATING & HANDLING

STORAGE

Goulds normal domestic storage preparation is suitable for protecting the pump during shipment in covered trucks. It also provides protection during covered storage at the jobsite, and for a short period between installation and start-up.

If the pump is to be idle and exposed to the elements for an extended period, either before or after installation, special precautions are required. One approach is to provide special preservatives and wrapping before shipment. However, after installation, the protective wrappings will have been removed. Therefore, application of preservatives after installation is considered good practice. The driver and coupling manufacturers should be contacted for recommendations on preservations and protection procedures.

It is considered good practice to rotate the shaft on pumps which contain ball or roller bearings approximately 30° every few weeks.

UNCRATING

Care should be taken when uncrating pumps. If shipment is not delivered in good order and in accordance with the Bill-of-Lading, note the damage or shortage on both receipt and freight bill. **MAKE ANY CLAIMS TO THE TRANSPORTATION COMPANY PROMPTLY.**

Instruction sheets on various components as well as the Instruction Book for the pump are included in the shipment. **DO NOT DISCARD!**

HANDLING

Care should be used in moving pumps. Pumps should not be hoisted by eyebolts. These eyebolts are used for removing upper half casings or back pull out

assemblies for maintenance and inspection. Bedplate mounted units should be slung under bedplate (under pump and driver).

I - C. LOCATION

Pumping unit should be placed as close as practical to the source of supply. Floor space and head room allotted to the unit must be sufficient for inspection and maintenance. Be sure to allow for crane or hoist service. On horizontally split case pumps, always allow sufficient head room to remove the upper half casing.

I - D. INSTALLATION — "CLOSE-COUPLED" AND "VERTICAL" PUMPS

"CLOSE-COUPLED"

A "close-coupled" pump may be mounted horizontally or in a vertical position provided motor is above pump. The unit should be bolted to a concrete foundation or an adequately supported structure, substantial enough to absorb any vibration and to form a permanent rigid support for the unit. All units have hold-down bolt holes in the motor feet and pump/adapter feet. Depending upon the motor frame, the pump or adapter feet may be higher or lower than the motor feet. Shim as required, then bolt all feet securely to support or foundation. Since the pump is mounted on the motor, permanent alignment is "built in". No subsequent alignment is necessary.

"VERTICAL"

Vertical pumps may be mounted directly on a pit, using either the pump support plate only or in conjunction with a pit or tank cover. The units are shipped completely assembled except for motor, pit cover (if any), and float controls. Check all bolts and nuts on the entire unit to make sure they are securely tightened. Connect float and controls as shown on Sectional View in Section VIII-D.

Installation must be done with care to avoid damage and insure proper operation. It is recommended that a man be stationed inside the pit, whenever possible, to assist in the initial installation.

Lower the assembled pump (less motor) carefully into the pit. Guide unit carefully so that it does not strike sides of pit. When unit is in place, level the support plate. Shim under support plate as required. Pump must hang perfectly vertical to avoid placing a bending stress on the unit.

The support plate should be bolted to an adequately supported structure, substantial enough to absorb any vibration and to form a permanent, rigid support for the unit.

Place motor on motor support and tighten bolts (with lock washers) snugly.

Alignment of the coupling is of extreme importance for trouble-free mechanical operation. Check for alignment by laying a straight edge across coupling hubs at four points 90° apart. See Fig. 1. When the straight edge rests evenly at all four points, the coupling is aligned.

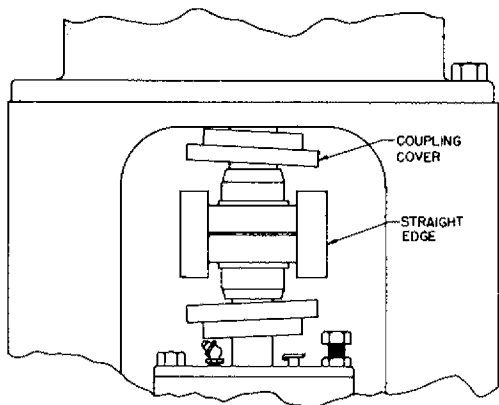

Figure 1

244-94

The machined faces of the motor support and motor will provide angular alignment. However, any foreign material or burrs on the surface will destroy this alignment. Make sure surfaces are clean and smooth.

I - E. INSTALLATION — "HORIZONTAL" PUMPS

Bedplate mounted units are normally mounted on a concrete foundation of liberal thickness poured on a solid footing, using a one-three-five mix. The foundation should be substantial in order to absorb any vibration and to form a permanent, rigid support for the pumping unit.

1. The location and size of foundation bolts are shown on the outline assembly drawing supplied for the unit.
2. When unit is mounted on a concrete foundation, each foundation bolt should be installed with a pipe sleeve around it to allow for adjustment.

The I. D. of the sleeve should be $2\frac{1}{2}$ -3 times the bolt diameter. Place a washer between the bolt head and sleeve to hold bolts. See Fig. 2.

Stuff waste around bolts to prevent concrete from entering between bolt and sleeve. Bolts should be of sufficient length so that they project through the nuts approximately $\frac{1}{4}$ " after allowance has been made for grouting, bedplate thickness, and nut thickness.

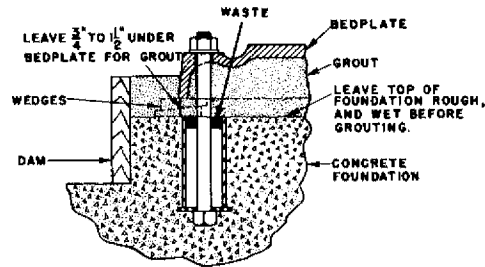

Figure 2

239-82

3. Put the unit in place on wedges. The wedges should be placed at four points as shown in Fig. 3. Some long installations may require additional wedges near the middle of the bedplate.

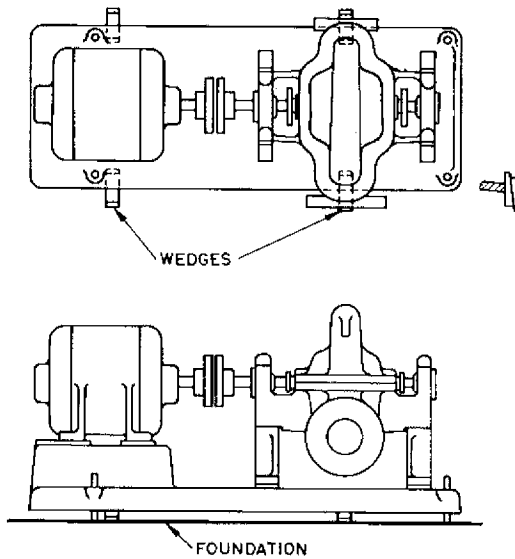

Figure 3

239-78

4. Disconnect coupling between pump and driver. Note: "Spider-Insert" couplings, as shown in Fig. 4, need not be disconnected.

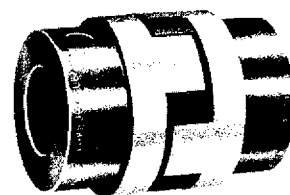

Figure 4

- By adjustment of wedges, bring the unit to an approximate level and provide the proper distance above the foundation for grouting ($\frac{3}{4}$ " to $1\frac{1}{2}$ "). Level or plumb the suction and discharge flanges. Bring the coupling halves into reasonable alignment.

Note: On some units, there are adjustment bolts on bearing frame or casing feet. These can be used for minor adjustment to level the pump. When properly adjusted, there will be approximately a $\frac{1}{4}$ " gap between foot and bedplate. NEVER ATTEMPT TO BRING FOOT FLUSH TO BEDPLATE. Do not attempt further adjustment to align pump. Do not "cock" pump during adjustment. Make sure pump rotates freely by hand. See Fig. 5.

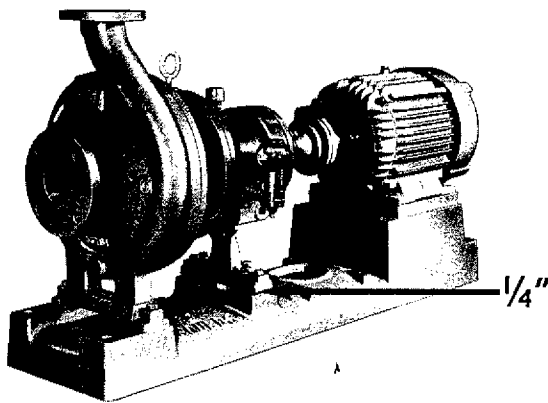

Figure 5

- Tighten foundation bolts, but only finger tight. Maintain the level of the bedplate. *Note:* Final tightening is done after pump is grouted and grout has set at least 48 hours.
- Build wood dam around foundation as shown in Fig. 2, and thoroughly wet top surface of foundation. Pour grout in hole provided in top of bedplate. Use of non-shrink grout is recommended. Grout should be thin enough to flow out under the bedplate but not so wet that sand and cement will separate. Grout should be puddled continuously as it is poured to expel the air and completely fill the space under the bedplate to the level of the grout hole. Strike along top of dam with trowel to give a neat finished appearance. Allow grout to harden at least 48 hours.
- Tighten foundation bolts.
- Tighten pump hold-down bolts.

I - F. ALIGNMENT PROCEDURES

GENERAL

Alignment of the pump and driver is of extreme importance for trouble-free mechanical operation. The following are suggested steps to establish the initial alignment of the unit.

NOTE: THIS IS AN INITIAL ALIGNMENT. The final alignment is done after the unit has been run under actual operating conditions. The final alignment procedure is outlined in Section III-E and must be followed. Make sure motor starting switch is "locked out" to prevent accidental rotation.

Any coupling manufacturer's instruction sheets, sent with the pump, should be studied and used when installing, aligning, or servicing coupling. Note that coupling hubs are not necessarily mounted flush with the shaft ends.

If instructions are not available, the following procedure may be used. The procedure is given for two basic coupling types:

- Flexible Coupling** — Normally furnished on all units except "back pull-out". Normally not assembled (except "spider-insert" type which are preassembled).
- Flexible Spacer Coupling** — Furnished as standard on all "back pull-out" units. Contains a removable spacer piece located between coupling hubs.

NOTE THAT ALIGNMENT IN ONE DIRECTION MAY ALTER ALIGNMENT IN ANOTHER. CHECK THROUGH EACH ALIGNMENT PROCEDURE AFTER MAKING ANY ALIGNMENT ALTERATION.

PARALLEL ALIGNMENT

Unit is in parallel misalignment when the shaft axes are parallel but not concentric. Shift driver as required.

In order to obtain vertical parallel alignment under actual operating conditions, the driver shaft may have to be set higher or lower (using thin shim stock) than the pump shaft due to differences in expansion rates. Pump expansion rates vary with pump design. The following is a suggested cold setting for motor driven units:

Frame Mounted Units

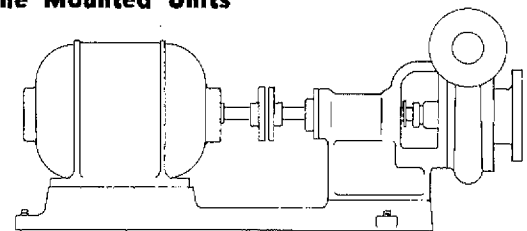

Figure 6

70908

Pumpage Temperature
Above Ambient
Temperature

Set
Motor
Shaft

Ambient	.004" - .006" Low
100°F	.002" - .004" Low
200°F	.000" - .002" Low
300°F	.000" - .002" High

Pedestal Mounted Units

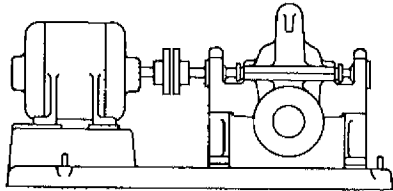

239-78

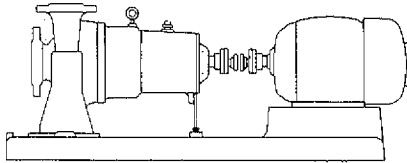

86597

Figure 7

Set motor shaft .002" - .004" low regardless of pumpage temperature.

Casing Mounted Units

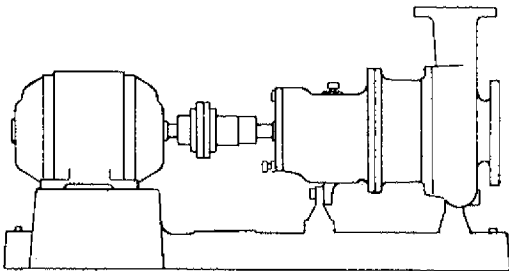

83340

Figure 8

Pumpage Temperature Above Ambient Temperature	Set Motor Shaft
Ambient	.002" - .004" Low
100°F	.000" - .002" High
200°F	.004" - .006" High
300°F	.008" - .010" High
400°F	.012" - .014" High
500°F	.016" - .018" High

To check the parallel alignment:

1. Flexible Couplings

Place a straight edge across both coupling hubs at four points 90° apart. The unit will be in parallel alignment when the straight edge rests evenly on both halves. See Fig. 9.

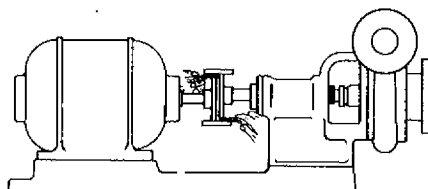
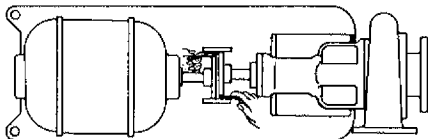

Figure 9

70909

2. "Spider-Insert" Couplings

Place a straight edge across both coupling hubs at four points 90° apart. The unit will be in parallel alignment when the straight edge rests evenly on both halves. See Fig. 9.

3. Flexible Spacer Couplings

Place a dial indicator on one hub and rotate that hub 360° while taking readings on the outside diameter of the other hub. When indicator does not deflect more than .002" total, parallel alignment is achieved. See Fig. 10.

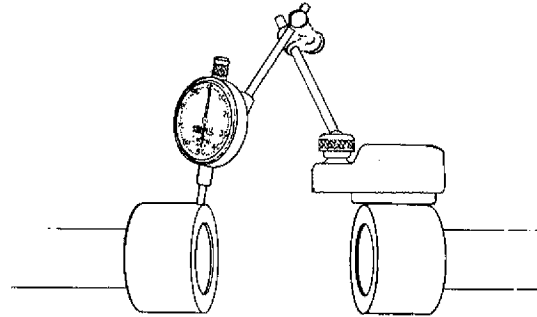

Figure 10

ANGULAR ALIGNMENT

Unit is in angular misalignment when the shaft axes are concentric, but not parallel. Shim unit as required.

1. Flexible Couplings

The normal "gap" (distance between coupling halves) is approximately 1/8". However, the coupling manufacturer's instructions should be followed. Insert a "feeler" or taper gauge at 90° intervals on the circumference of the hubs. When the "gap" is identical within .002", the unit is in angular alignment. See Fig. 11.

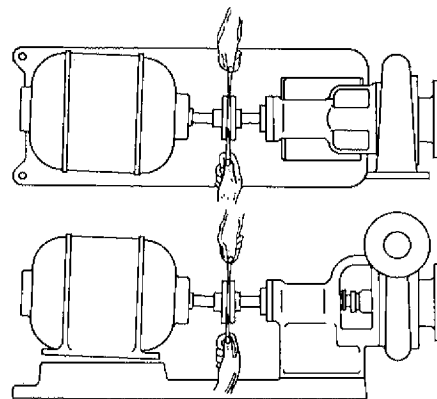

Figure 11

70910

2. "Spider-Insert" Couplings

The normal "gap" (distance between hub and insert) is approximately 1/16". However, the

coupling manufacturer's instructions should be followed. Check alignment by using calipers at 90° intervals on the circumference on the outer end of hubs. When caliper measurements are identical, the unit is in angular alignment. See Fig. 12.

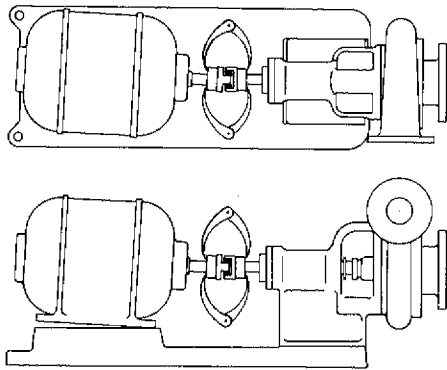

Figure 12

70923

3. Flexible Spacer Couplings

Place a dial indicator on one shaft hub and rotate that hub 360°. Take readings from the face of the other hub. Alignment is achieved when indicator does not deflect more than .002". See Fig. 13.

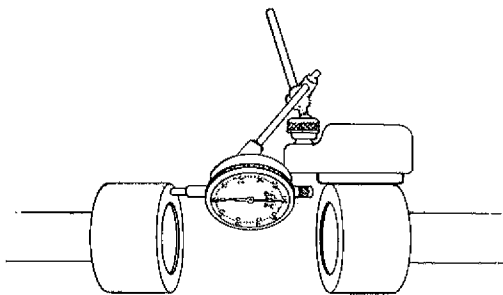

Figure 13

I - G. PIPING — GENERAL

1. All piping must be supported independently of the pump. The piping should always "line-up" naturally with the pump flanges. NEVER DRAW THE PIPING INTO PLACE BY USE OF FORCE AT THE FLANGED SUCTION AND DISCHARGE CONNECTIONS OF THE PUMP, AS THIS MAY IMPOSE DANGEROUS STRAINS ON THE UNIT AND CAUSE MISALIGNMENT BETWEEN PUMP AND DRIVER.

2. The piping, both suction and discharge, should be as short and direct as possible. Avoid all unnecessary elbows, bends, and fittings, as they increase the friction losses in the piping. The size of pipe and fittings should be carefully selected and of sufficient size to keep the friction losses as low as practical.

3. Piping must not be connected to the pump until the grout has thoroughly hardened and the foundation bolts, as well as driver and pump hold down bolts have been tightened.

4. When handling liquids at elevated temperatures, it is suggested that expansion loops or joints be properly installed in suction and/or discharge lines so that linear expansion of the piping will not draw the pump out of alignment.

If such expansion loops or joints are not used, the forces and moments, due to thermal expansion of the piping system, that can act upon the pump inlet and discharge flanges must be determined and must not exceed the limits permissible for the specific pump in question.

Such installations require extremely careful and precise attention to hot alignment procedures. See Section III-E, titled "Alignment-Final."

5. On units handling corrosives, the piping can be arranged so that corrosives can be flushed from pump prior to opening unit for service. See Fig. 14. During operation, valves "1" and "3" would be closed, "2" and "4" open. Prior to dismantling, close valves "2" and "4", open "1" and "3". Introducing water at valve "3" will allow water to flush pump and drain at valve "1".

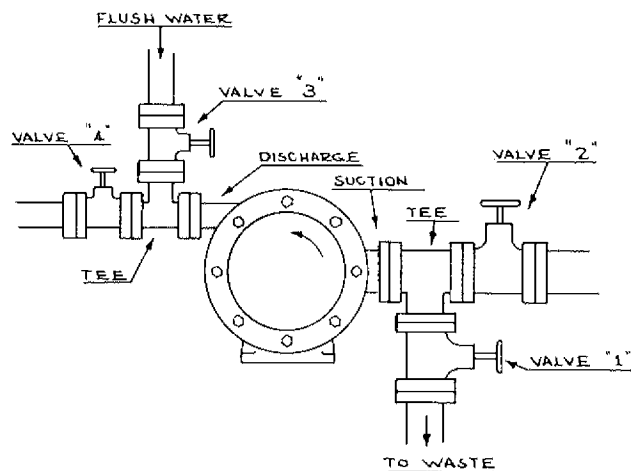

Figure 14

59636

I-H. PIPING — SUCTION

GENERAL

Properly installed suction piping is of extreme importance for trouble-free centrifugal pump operation.

1. Use of elbows close to the pump suction flange should be avoided. Where used, elbows should be long radius.

On double suction pumps, if an elbow must be used at the pump suction flange, it must be in a *vertical position only*. If an elbow must be used in other than a vertical position, it is permissible only providing there is a minimum of two diameters of straight pipe between the elbow and pump suction flange.

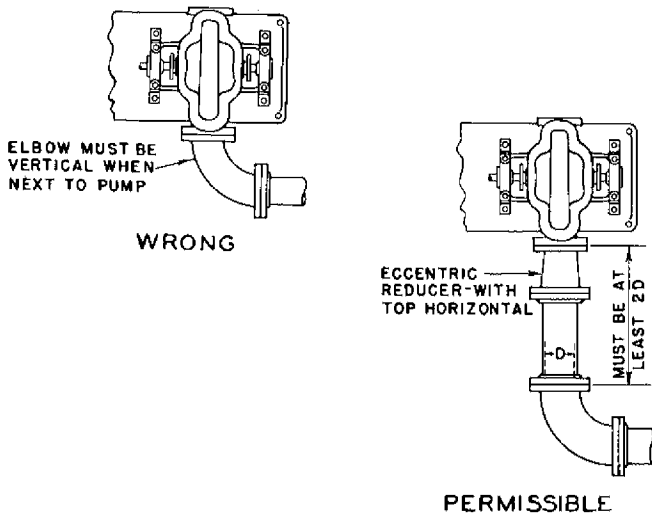

Figure 15

239-81

2. The suction pipe should never be of smaller diameter than the pump suction. Use of suction pipe one or two sizes larger than the pump suction, with a reducer at the pump suction flange, is desirable.
3. Reducers, if used, should be eccentric and preferably at the pump suction flange, sloping side down.

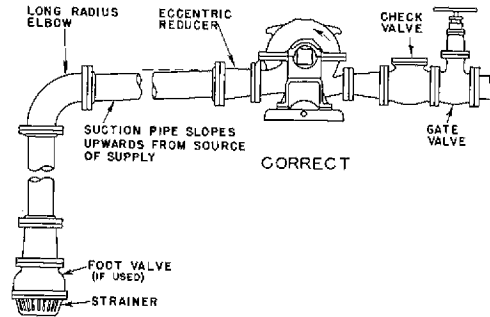
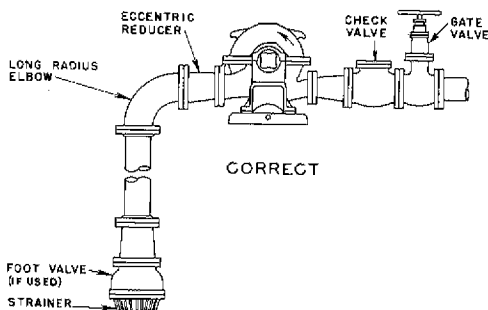

Figure 16

239-81

4. A CENTRIFUGAL PUMP SHOULD NEVER BE THROTTLED ON THE SUCTION SIDE.
5. Suction strainers, when used, should have a net "free area" of at least three times the suction pipe area.
6. Separate suction lines should be used when more than one pump is operating from the same source of supply. If it is not possible to have separate lines, piping arrangement shown in Fig. 17 is recommended.

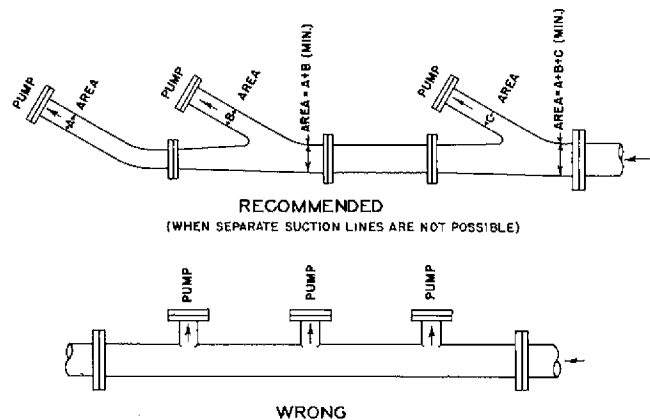

Figure 17

239-85

SUCTION PIPING DESIGN FOR LARGE PUMPS

Large units taking their suction supply from sumps require special attention. A properly designed sump is a must. The larger the unit, the more important these considerations become. A 3000 GPM pump should be considered a large unit.

The following sketches will show the preferred pipe arrangement within the sump. Pipe should be located near the back wall of the sump as shown in Fig. 18 and should not be subjected to rapid changes in direction of the flow pattern.

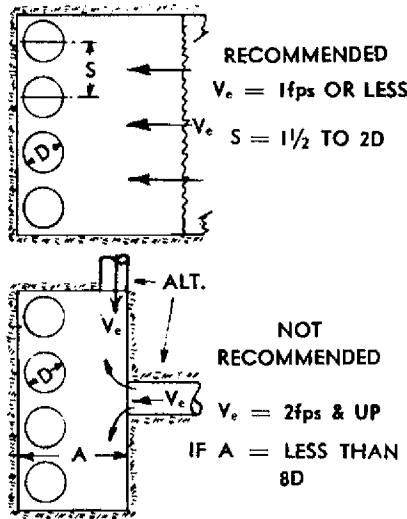

Figure 18 a

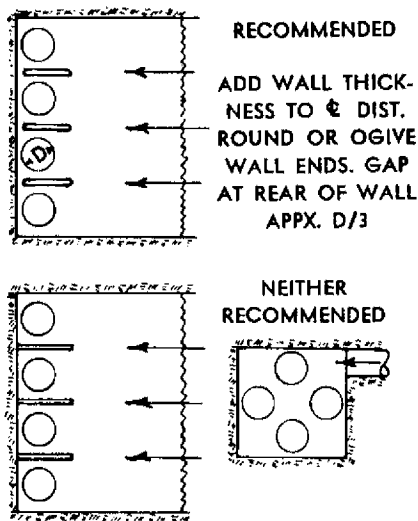

Figure 18 b

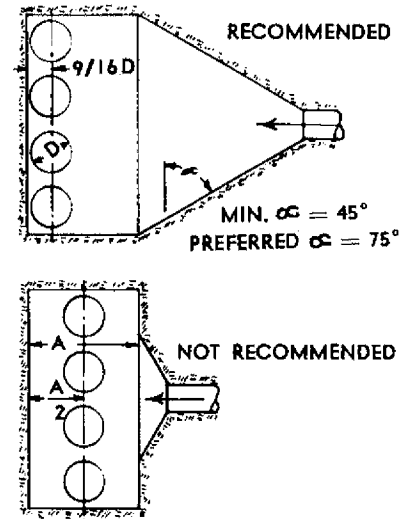

Figure 18 c

The velocity of the water approaching the pump suction pipe should be kept to a maximum of one foot per second to avoid air being drawn into the pump. Pump suction inlet velocities and submergence (the height of the water above the pump inlet) are two additional factors that must be considered. These factors vary so greatly with the size and capacities of the individual pumps and systems that past experience, or a good reference, should be relied upon in arriving at these values.

The suction pipe should be sized to obtain a flow velocity of 4 to 7 feet per second. Changes in flow direction should be avoided wherever possible, especially near the pump suction. A reducer at the pump suction flange to smoothly accelerate and stabilize flow into the pump is desirable.

Refer to the nearest Goulds representative for further information.

INSTALLATIONS WITH PUMP ABOVE SOURCE OF SUPPLY — SUCTION LIFT

1. Keep suction pipe free from air pockets — See Fig. 16.
2. Piping should slope upwards from source of supply.
3. No portion of piping should extend above the pump suction nozzle.
4. All joints *must* be air tight.

INSTALLATIONS WITH PUMP BELOW SOURCE OF SUPPLY — SUCTION HEAD OR FLOODED SUCTION

1. A gate valve should be installed in the suction line to permit closing of the line for pump inspection and maintenance.
2. Keep suction pipe free from air pockets.

3. Piping should be level or slope gradually downward from the source of supply.
4. No portion of the piping should extend below pump suction flange.
5. The size of entrance from supply should be no smaller than the suction pipe.
6. The suction pipe should be adequately submerged below the liquid surface at the source of supply.

I - J. PIPING — DISCHARGE

1. Gate and check valves should be installed in the discharge line. The check valve should be located between the gate valve and pump to permit inspection of the check valve. The gate valve is required for priming, regulation of flow and for inspection and maintenance of the pump. The check valve is required to prevent reverse flow through the pump when the driver is turned off.
2. Increasesers, if used in discharge line, should be placed between the pump and check valves.
3. If quick-closing valves are installed in the system, cushioning devices should be used to protect the pump from surges and water hammer.

I - K. CONNECTION OF PIPING

Connect suction and discharge piping to the pump. Rotate pump shaft several times by hand to be sure there is no binding and that all parts are free. Recheck alignment. NOTE: On non-metallic pumps, use gaskets which are suitable for the flanges. Teflon envelope style is recommended.

I - L. ROTATION

SERIOUS DAMAGE MAY RESULT IF PUMP IS RUN IN WRONG DIRECTION. BEFORE COUPLING IS CONNECTED, THE MOTOR SHOULD BE WIRED AND THE DIRECTION OF ROTATION CHECKED. The direction of rotation is marked on the pump. Make sure driver rotates in the same direction.

I - M. CONNECTION OF COUPLING

Connect coupling. Follow the manufacturers instructions. "Spider-Insert" type couplings are pre-assembled. If a coupling guard is furnished with the unit, make sure it is securely fastened.

SECTION II — PREPARATION FOR OPERATION

II - A. PUMP BEARINGS

OIL LUBRICATION

Oil lubricated pumps are not lubricated at the factory. A high quality turbine type oil, with rust and oxidation inhibitors, should be used. Constant level oilers are supplied with most oil lubricated pumps. They are included in the box of fittings which accompanies the pump. The oiler was adjusted to maintain proper oil level before leaving the factory. The adjustment should be checked in case this setting was disturbed. See Figure 19. Correct dimensions for A and B are giving in Section VIII-A. Check the assembly dimension print for proper location.

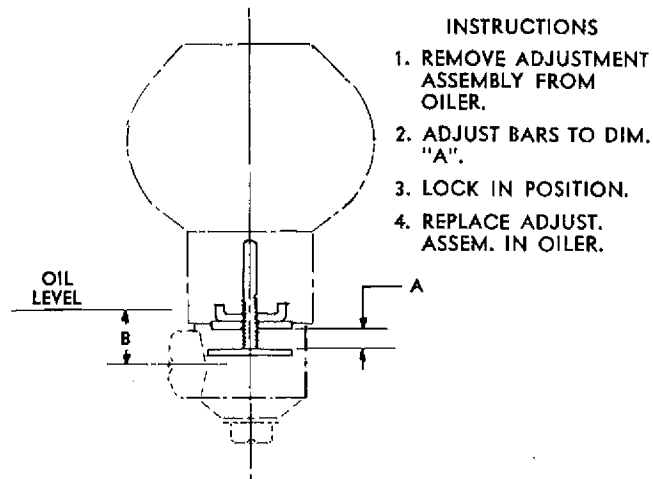

Figure 19

72531

Under normal operating conditions, an oil of 300 SSU viscosity at 100°F. (approximately SAE-20) should be used. For extreme conditions refer to the factory or a lubrication expert for a recommendation.

Fill the bottle with the proper grade of oil and replace in the oiler housing. Oil reservoir in bearing housing is filled when an oil level remains in the bottle. Several fillings of bottle will be required. Never fill through the oil vent or through the oiler without use of the bottle.

GREASE LUBRICATION

Grease lubricated pumps can be identified by the grease fittings located on the bearing housing. Sufficient lubricant is inserted at the factory for 2,000 hours of operation. DO NOT GREASE AT TOO FREQUENT INTERVALS.

It is suggested that additional or replacement lubricant be added after 2,000 hours or at three-month intervals.

The lubricant should be renewed in the housings at least once annually. This should be done when the annual overhaul is made.

The grease should be of sodium lithium base, NGLI #2 consistency. DO NOT USE GRAPHITE. Further greasing instructions are included in Section VIII-A.

"VERTICAL" PUMP BEARINGS

The bearing above the pump support plate is a ball bearing and is grease lubricated. Follow the previous instructions for grease lubrication.

The pump steady bearings (below the pump support plate) are sleeve type and made of various materials depending upon the application of the pump. See Section VIII-A for specific details.

"CLOSE-COUPLED" PUMPS

"Close-coupled" pumps contain no pump bearings. The only bearings in the unit are contained within the motor. Make sure that the motor bearings are properly lubricated. Refer to the motor manufacturer for instructions.

II - B. DRIVER BEARINGS AND COUPLING

Check to be sure that driver bearings are properly lubricated. Contact the motor manufacturer for lubrication instructions. Refer to coupling instructions supplied separately for coupling lubrication.

II - C. STUFFING BOXES

PACKING

Before packing the stuffing box, make sure box is clean and contains no foreign material. If unit has a metal lantern ring, assembled with the pump, make sure ring is outside the stuffing box.

Stuffing box packing is furnished in the box of fittings which accompanies the pump. When packing the stuffing box, refer to the Sectional Assembly in Section VIII-D for the arrangement of packing rings and lantern ring. Depending upon the particular pump and/or application, the lantern ring may be in the middle or bottom of the stuffing box, incorporated in another part or not used at all.

Some packing rings are die-formed and special care must be taken during installation. To install, twist the ring sideways just enough to get it around the shaft or sleeve. **DO NOT ATTEMPT TO PULL RINGS STRAIGHT OUT.** See Fig. 20. Another form of packing ring is the bulk-type packing which is cut to the proper length. Each piece should be placed around the shaft or sleeve and the ends of the packing should just meet to form a smooth, perfect ring. If necessary, the ends should be trimmed to obtain this fit.

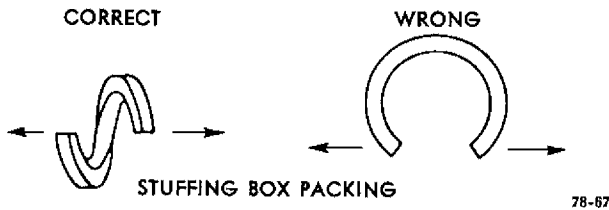

Figure 20

There are two basic types of lantern rings — Teflon and metal. Two-piece Teflon lantern rings are supplied in most units. Install as shown in Fig. 21. Note: 2 pieces make one ring. Notches must face one another but need not be aligned.

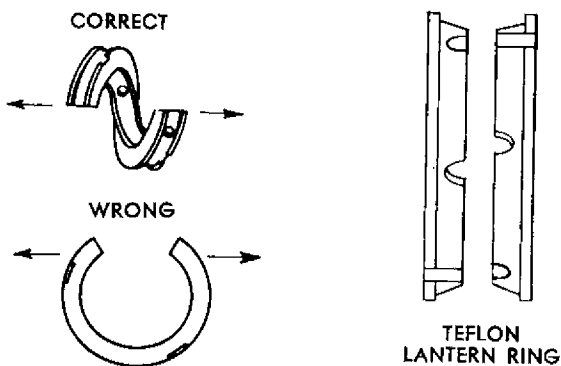

Figure 21

To pack the stuffing box, install the packing and lantern ring in the proper sequence. Each ring should be installed separately. Firmly seat each ring. Use of a wooden split bushing is recommended. See Fig. 22. Use gland to jack the bushing and ring into the box. Stagger joints in each ring 90°. Make sure center of lantern ring lines up with flush tap in the stuffing box. *Any extra rings are spares.*

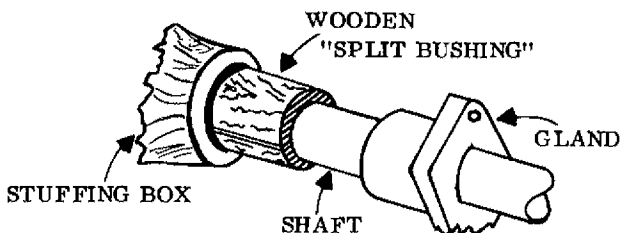

Figure 22

Tighten the gland nuts evenly but not tight. Follow adjustment procedure outlined in Section III-D.

REMOVAL OF PACKING

To remove packing from the stuffing box, the following steps should be followed:

1. Remove gland assembly.
2. Remove packing with a "packing hook."
3. Remove lantern ring by inserting a wire hook into the ring on the outer edge.
4. Clean the stuffing box.
5. On horizontally split case pumps, an alternate method of removing packing is to remove the upper half casing. See Section VIII-C. Remove packing and lantern ring and inspect sleeves. If deeply grooved, sleeves should be replaced.

MECHANICAL SEALS

When mechanical seals are furnished, the description and identification is indicated on the order write-ups which are a part of the order acknowledgement, dimension print, and the packing list. Separate seal manufacturers' installation drawings are attached to the pump. The seals are installed and adjusted at the factory. The manufacturer's drawings should be filed for future use in maintaining the seal and in adjusting the seal when the pump is disassembled. To properly prepare the seal for operation, various cooling and flushing flows may have to be connected. In some cases, these flows are recirculated from the pump casing; in others, liquid from an outside source may be used. Connect cooling and flushing flows to seal as directed in subsequent steps.

II - D. CONNECTION OF SEALING LIQUID OR GREASE LUBRICATOR (PACKED BOX)

If the stuffing box pressure is above atmospheric pressure, and the pumpage is clean, normal gland leakage of 40 to 60 drops per minute is usually sufficient to lubricate and cool the packing and sealing liquid is not required.

Sealing liquid or grease lubricator is required when:

1. Abrasive particles in the pumpage could score the shaft or sleeve.
2. Stuffing box pressure may be below atmospheric pressure due to pump running with suction lift, or when suction source is under vacuum. Under these conditions, the packing will not be cooled and lubricated and air will be drawn into the pump.

SEALING LIQUID

Sealing liquid may be supplied by recirculation of pumpage through a line from the casing to the stuffing box. If the pumpage is abrasive, an outside source of clean compatible liquid must be used at a pressure of 30 to 50 PSI above suction pressure.

GREASE LUBRICATOR

The grease lubricator is supplied when the use of recirculating pumpage or outside sealing liquid is not desired. The grease should be insoluble in the pumpage.

II - E. CONNECTION OF COOLING WATER PIPING

QUENCH GLAND

Most pumps which contain stuffing box packing have quench glands. Quenching prevents heat transfer along the pump shaft to the bearings. Quenching is also most important for smothering vapors and fumes given off at the stuffing box. This is particularly true on applications such as hot water.

The quenching liquid (usually water) must be from an outside source. It should be piped, with flexible pipe, into the tapped opening on top of the stuffing box gland. A shut-off valve should be installed.

BEARINGS

Bearing cooling is available on some units. When it is available, cooling water must be connected to the jacket when pumping hot liquids. See the temperature limits listed under "Construction Details" in Section VIII-D. Valves should be installed in the coolant supply lines to regulate the flow.

STUFFING BOXES

Some units are equipped with cooling jackets around the stuffing box as standard. It is optional on various other models. Coolant lines are connected in the same manner as the bearing cooling lines.

CASING PEDESTALS

On some models, water cooled pedestals are available. Connection of coolant lines is made in the same manner as above.

MECHANICAL SEALS

Seal materials (carbon, ceramic, teflon, etc.) are suitable for use at temperatures to 500°F. (212° to 250°F. if seal has rubber parts). However, for satisfactory operation, there must be a liquid film between the seal faces to lubricate them. If the liquid flashes to vapor, the faces will run dry and be damaged. To prevent this, the liquid must be cool. In general, this requires that the liquid be cooled so that the vapor pressure is well below the stuffing box pressure. Doubtful cases should be referred to Goulds for a recommendation. Refer to seal manufacturer's drawing for location of taps. Some methods which may be used to cool the seal are:

1. Dead Ended Seal Chamber

No liquid is circulated through the stuffing box. The isolated or "dead ended" liquid around the seal is cooled by circulating water in the stuffing box jacket, if any.

2. Cool Liquid Flushing — External Source

A clean, cool compatible liquid is injected from an outside source directly into the seal chamber. The flushing liquid must be at a pressure 20 to 40 PSI greater than the pressure in the stuffing box. One-half to two GPM should be injected. A control valve and rotometer placed in the inlet line permits accurate regulation. Cooling water can be circulated through the stuffing box water jacket (if any) in addition to the external flush.

3. Cool Liquid Flushing — Product Cooling

In this arrangement, pumped liquid is piped from the pump casing, cooled in an external heat exchanger, then injected into the seal chamber. A control valve together with a rotometer and/or a dial thermometer should be installed in a line from the exchanger to the seal chamber. One-half to two GPM should be circulated. Cooling water, one to three GPM, should be circulated through the stuffing box jacket, if any.

II - F. CONNECTION OF DRAIN PIPING

All units contain tapped openings around the stuffing box for draining leakage. On corrosion resistant units, a drain pan is supplied with a tapped opening. Check the assembly dimension print for size and location.

II - G. CONNECTION OF EQUALIZING PIPING

Some multi-stage pumps have equalizing piping to equalize pressure on the stuffing boxes (see Sectional View in Section VIII-D). This piping is in the box of fittings which accompanies the pump. The ends of the piping must be connected to the openings in each stuffing box.

II - H. IMPELLER ADJUSTMENT

Some end suction pumps, in addition to vertical pumps, have means of adjusting impeller clearance within the casing. The clearance was set at the factory, but in transit, the clearance may have been lost. Proper clearance must be attained before a pump is operated or **SERIOUS DAMAGE MAY OCCUR**. Check and reset impeller clearance by method described in Section VIII-B.

SECTION III — STARTING PUMP

III - A. CHECKING FOR FREE TURNING

Rotate shaft by hand to be sure rotating element is free. If element rubs or binds:

1. Check alignment
2. Pipe loads should be removed
3. Check impeller clearance (if external adjustment is possible) as outlined in Section VIII-B.
4. If unit is equipped with leveling bolts on frame or casing foot, check to be sure that bolts are not overtightened.

III - B. REGULATION OF COOLING AND FLUSHING LIQUIDS

The supply of liquid to any cooling jackets, quench glands, or mechanical seals should be regulated by valves in the supply line. *Approximate* flow rates are as follows:

Quench Glands — $\frac{1}{2}$ to 1 GPM

Cooling Jackets — 1 to 3 GPM

Mechanical Seals — $\frac{1}{2}$ to 2 GPM

The cooling lines should be checked periodically to see that they have not become clogged.

III - C. PRIMING

The pump must always be fully primed and the suction pipe full of liquid before pump is started.

If pump is run dry, the rotating parts within the pump may seize to the stationary parts since they depend upon the liquid being pumped for lubrication.

Several different methods of priming can be used, depending upon the type of installation and service involved.

Vertical sump pumps, when submerged, need not be primed since the pump is filled with liquid.

NOTE: ON GLASS-LINED PUMPS, THE THERMAL SHOCK LIMIT OF THE GLASS VARIES WITH THE CONDITIONS OF OPERATION. DO NOT INTRODUCE LIQUID TO PUMP IF TEMPERATURE DIFFERENCE BETWEEN LIQUID AND PUMP IS OVER 100°F. GRADUALLY HEAT PUMP BEFORE INTRODUCING HOT LIQUIDS.

SUCTION SUPPLY ABOVE PUMP

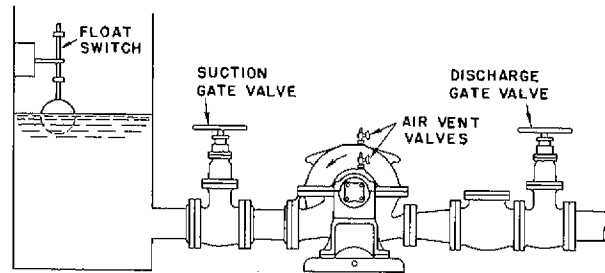

Figure 23

239-77

When pump is installed as shown in Fig. 23, pump will prime itself. Open gate valve on suction and close discharge gate valve. Open air vent valves until all air is expelled and water flows through openings. Close air vent valves, start pump and open discharge gate valve. Pump will continue to be primed for any future starting.

This method is the simplest and, particularly for automatic operation, the safest. A float switch in the suction reservoir can be arranged to stop pump, should there be failure of liquid supply.

PRIMING WITH FOOT VALVE

With pump installed on suction lift, with foot valve at end of suction line, priming can be done any of the following three ways:

1. Outside Supply

Close discharge gate valve, open air vent valves and open valve in priming supply line until all air is expelled and water issues from vent openings. Close air vent valves, close valve in priming supply line, and start pump; then open discharge gate valve.

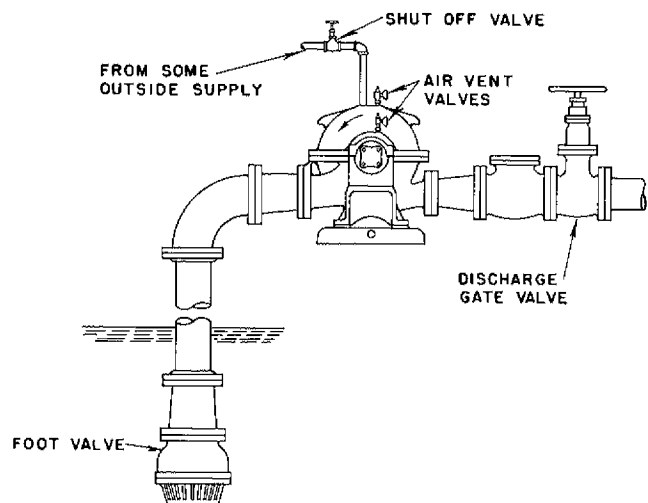

Figure 24

239-78

2. *By Separate Hand, or Manually Controlled, Priming Pump*

Close discharge gate valve (keep air vent valves closed) and open valve in line to priming pump. Exhaust air from pump and suction piping until water flows from priming pump. With priming pump running, close valve in priming line, start pump and open discharge gate valve.

An alternate method is to reverse connections on priming pump and extending priming pump suction to source of liquid supply. The pump may be primed by pumping liquid into casing until liquid comes out of the open air vent valves.

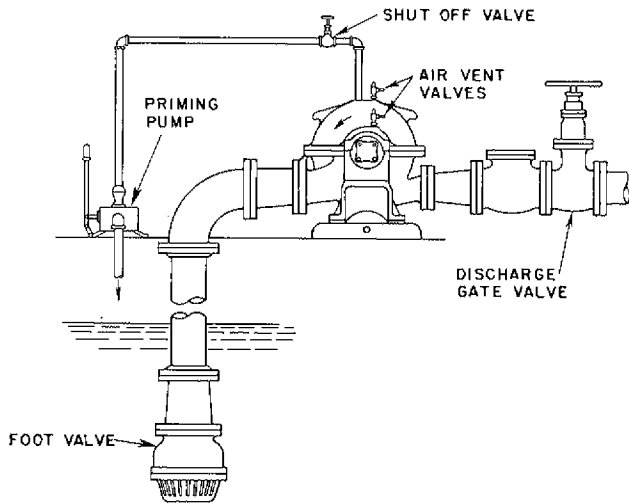

Figure 25

239-78

In either of these methods (1) and (2), the pump will remain primed, provided foot valve is tight. Any failure, however, of foot valve when pump is standing idle, will permit the pump to lose its prime. During long idle periods, the pump can also lose its prime through leakage from stuffing boxes.

3. *Bypassing Around Discharge Check Valve*

This method can be used only when there is liquid under some pressure in the discharge line. The original prime must be effected from some outside source. After subsequent idle periods, open air vent valves and open valve in bypass line around discharge check and gate valves until liquid flows from air vent openings. Close air vent valves and bypass valve, start pump and open discharge gate valve.

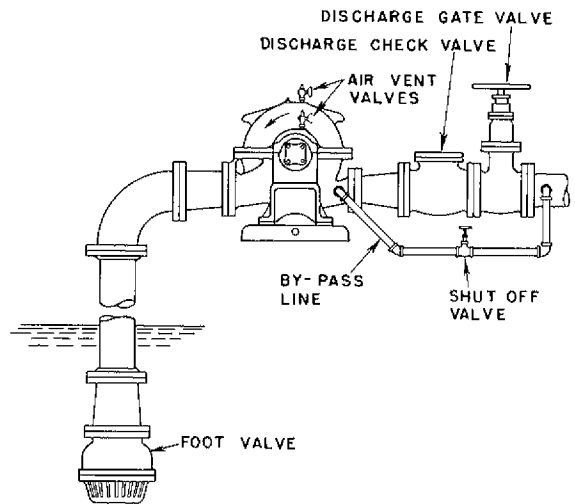

Figure 26

239-78

The valve in bypass can be left open, in which event, during idle periods, loss through foot valve is constantly replenished from discharge line. This system is used for automatic operation where idle periods are of short duration and there is no danger of exhausting all liquid from discharge line, due to a leaky foot valve. The foot valve must be capable of withstanding static head pressure of the system.

PRIMING BY EJECTION

On suction lift installation, an ejector, operated by steam, compressed air, or water under pressure, and connected to tapped opening in top of casing can be used to remove air from casing and suction line, thus priming the pump. See Fig. 27.

Close discharge gate valve, open valve "E" in steam, air or water pressure supply line. Open valve "S" in suction pipe of ejector connected to pump casing. Air will be evacuated and liquid will be drawn up into suction pipe and pump casing. When all air is evacuated, start pump, close valve "S" and valve "E", and open discharge gate valve.

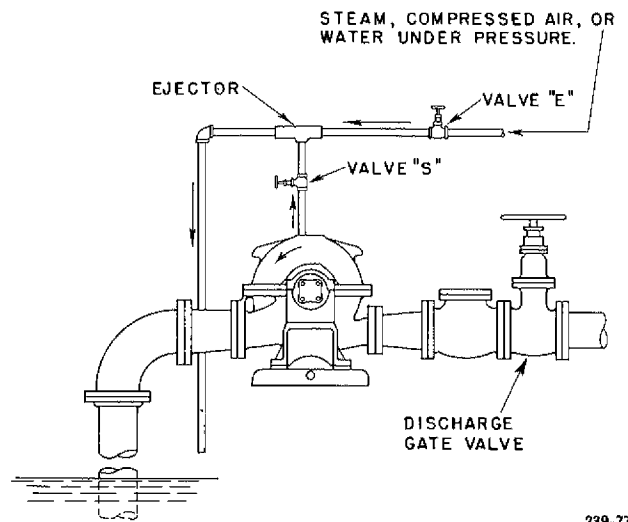

Figure 27

239-77

PRIMING BY AUTOMATIC PRIMER PUMP

Where there is a fluctuating suction lift that occasionally might drop below the normal limits of the pump, or for installations where there is any quantity of air entrained in the pumpage, the system shown in Fig. 28 is very well adapted.

A vacuum tank and a vacuum gauge can be installed near the primer pump and the vacuum switch set to automatically start or stop the primer pump according to the vacuum required to keep the system primed.

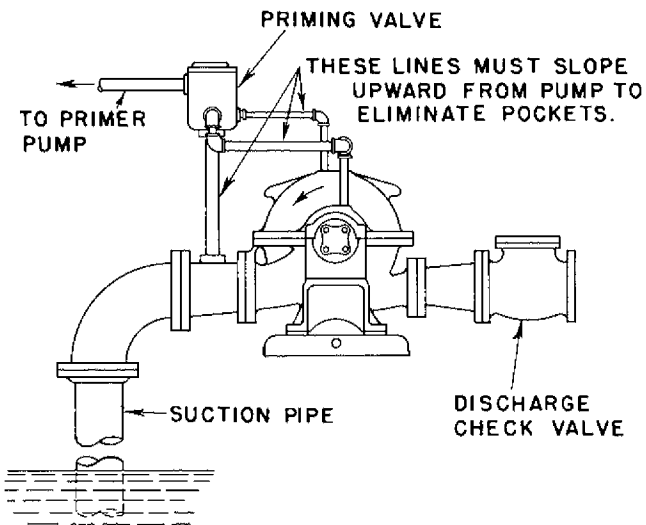

Figure 28

238-77

III - D. INITIAL INSPECTION AFTER STARTING

PACKED BOX

With pump running at rated speed, the stuffing box gland can be adjusted. Draw gland nuts up evenly and only 1/6 of a turn at a time, allowing sufficient time between adjustments for the packing to adjust itself and the effect on the leakage to be observed. If any sign of heating is evident, shut down the pump and allow the box to cool. Several starts may be necessary before the box runs cool. Do not back off the gland nuts on a hot box as this will usually result in liquid leaking between the outer edge of the packing and the stuffing box bore. Remember that it takes newly-installed packing some time to "run in" and that during this period, frequent attention and careful adjustments are necessary. See Section IV-A.

MECHANICAL SEAL

The mechanical seal was adjusted at the factory. If the seal leaks slightly when pump is first started, a few

hours run-in will allow seal to adjust itself. NEVER RUN SEAL DRY. MAKE SURE COOLING FLOW LINES, IF ANY, ARE OPERATING PROPERLY.

III - E. ALIGNMENT — FINAL

Final adjustment can only be accomplished after the unit has been run under actual operating conditions for a sufficient length of time to bring the unit up to operating temperature.

After this warm-up period has elapsed, stop the unit and IMMEDIATELY DISCONNECT THE COUPLING AND CHECK THE ALIGNMENT. On "Back-Pull Out" end suction units, the frame foot should be loosened to relieve any strain due to thermal expansion. On units which have jacking bolts on the foot, loosen the hold-down bolts. On units which have a slotted hole on the foot near the bearing frame, loosen the foot-to-bearing frame bolt. Make sure motor switch is "locked out" to prevent accidental rotation. After a minute or two, retighten foot bolts.

Repeat each alignment procedure outlined in Section IF.

Reconnect coupling.

Check final alignment after approximately one week of operation.

III - F. DOWELING

Some units do not require doweling since lock washers are furnished which hold the pump and driver feet securely in place.

On other units, the pump and driver feet should be doweled after installation is completed, and the unit is in correct final alignment. Taper dowel pins, included in the box of fittings, are furnished for these units.

NOTE: ON ALL MULTI-STAGE UNITS, DOWEL PINS (IF SUPPLIED) SHOULD BE USED ON THE COUPLING END OF PUMP ONLY. DO NOT DOWEL FEET ON OUTBOARD END OF PUMP.

On units to be doweled (except those noted above), drill through two diagonally opposite feet of the pump into the bedplate. Use a reamer with a 1/4" per foot taper. The dowels should extend well into the bedplate but project above the pump feet. Drivers should also be doweled but the driver manufacturer should be contacted for instructions.

SECTION IV — OPERATION

IV - A. STUFFING BOX

1. *Stuffing boxes with packing rings — less quenching liquid or grease lubricator:*

Periodically inspect stuffing box to see that there is sufficient leakage to lubricate the packing and maintain a cool box. Never draw up packing so that the stuffing box heats, as this will cause damage to both packing and sleeve. Draw up gland nuts slowly and evenly and only when pump is running.

After pump has been in operation for some time and the packing has been completely run in, at least 40 to 60 drops per minute of the liquid should be allowed to trickle from the stuffing box at all times for cooling and lubricating the packing and shaft sleeve.

2. *Stuffing boxes with packing rings — with quenching liquid:*

The same precautions as described above apply. However, the amount of leakage through the packing cannot be easily determined, due to the quenching liquid. In most cases, the valve on the quenching liquid supply line can be shut off for a short period and the amount of leakage determined as in IV-A1. In no instance should the gland be drawn up tight. Never throttle the clean liquid supply into the stuffing box as a substitute for proper adjustment of packing — a steady flow from the seal cage into the pump is required to prevent entrance of pumpage into the packing.

3. *Stuffing boxes with packing rings — with grease lubricator:*

Operation is the same as directed in IV-A1, with the addition that the handle on the lubricator should be given a turn or two about every 100 hours of operation.

4. *Stuffing boxes with mechanical seal:*

This type of box requires no attention other than to make sure that the circulating lines do not become clogged.

IV - B. OPERATING AT REDUCED CAPACITIES

DO NOT operate a centrifugal pump at greatly reduced capacities or with discharge gate valve closed, because the energy required to drive the pump is converted into heat. The temperature of the liquid in the pump may increase until the boiling point is reached. If this occurs, the rotating parts are exposed to vapor with no lubrication and they may score or even seize to the stationary parts. **WARNING: IF RUNNING CLEARANCES HAVE ENLARGED DUE TO WEAR, SEIZURE MAY NOT TAKE PLACE AND CONTINUED OPERATION UNDER THESE CONDITIONS MAY CREATE AN EXPLOSIVE**

HAZARD DUE TO THE CONFINED VAPOR UNDER HIGH PRESSURE AND TEMPERATURE.

To guard against possible damage, protective devices are available, such as:

1. Liquid temperature relay or thermostat which will shut off the unit if the liquid temperature in the pump exceeds a predetermined maximum. This device guards against possible damage due to running the pump against a closed valve.
2. Constant open by-pass orifice between the pump discharge and any check or regulating valve in the discharge line. The liquid through the orifice is returned to the suction source. The amount of liquid bypassed is a function of input horsepower and the allowable temperature rise. This device also is insurance against damage due to running the pump against a closed discharge valve or very low flow conditions.
3. Bearing temperature relay which will shut the unit down if the bearing temperature exceeds a predetermined maximum.
4. Low suction pressure control which will shut off the unit should the suction pressure drop below a pre-established minimum. **A CENTRIFUGAL PUMP SHOULD NEVER BE THROTTLED FOR CAPACITY ADJUSTMENT ON THE SUCTION SIDE.**

IV - C. OPERATING AT REDUCED HEAD

On motor driven pumps, when discharge head or pressure is allowed to drop considerably below the rated point for any length of time, the motor should be watched for heating because the pump capacity increases with reduced head, as does horsepower consumption. If this condition is likely to persist, arrangements should be made either to manually or automatically throttle the discharge valve to build up head to a safe point.

IV - D. OPERATING WITH SURGE CONDITIONS IN LINE

If a pump is installed with a quick closing valve in discharge line that closes when pump is running, dangerous pressure surges may be built up that can cause damage to the pump or line. In services of this kind, some cushioning arrangement must be provided to protect the pumping equipment.

IV - E. OPERATING UNDER FREEZING CONDITIONS

When exposed to freezing conditions and pump is standing idle, liquid inside the pump should be drained by removing drain plugs in bottom of casing and opening air cocks at top. Liquid inside cooling jackets or glands should also be drained.

SECTION V — TROUBLE CHECK LIST

V - A. NO LIQUID DELIVERED

1. Pump not primed — casing and suction pipe not completely filled with liquid.
- *2. Speed too low.
3. Discharge head too high. Check system head (particularly friction loss).
4. Suction lift too high (suction pipe may be too small or long, causing excessive friction loss). Check with vacuum or compound gauge.
5. Impeller or suction pipe or opening completely plugged.
6. Wrong direction of rotation or impeller installed backwards.
7. Air pocket in suction line.
8. Stuffing box packing worn — or liquid seal plugged — allowing leakage of air into pump casing.
9. Air leak in suction line.
10. Not enough suction head for hot or volatile liquids. Check carefully as this is a frequent cause of trouble on such service.

V - B. NOT ENOUGH LIQUID DELIVERED

1. Pump not primed — casing and suction pipe not completely filled with liquid.
- *2. Speed too low.
3. Discharge head higher than anticipated. Check system head (particularly friction loss.)
4. Suction lift too high (suction pipe may be too small or long, causing excessive friction loss.) Check with vacuum or compound gauge.
5. Impeller or suction pipe or opening partially plugged.
6. Wrong direction of rotation or impeller installed backwards.
7. Air pocket in suction line.
8. Stuffing box packing worn — or liquid seal plugged — allowing leakage of air into pump casing.
9. Air leak in suction line.
10. Not enough suction head for hot or volatile liquids. Check carefully as this is a frequent cause of trouble on such service.

11. Foot valve too small.
12. Foot valve or suction pipe not immersed deeply enough.
13. Mechanical defects:
 - Impeller clearance too great
 - Impeller damage

V - C. NOT ENOUGH PRESSURE

- *1. Speed too low.
2. Air or gases in liquid.
3. Impeller diameter may be too small.
4. Mechanical defects:
 - Impeller clearance too great
 - Impeller damaged
5. Wrong direction of rotation or impeller installed backwards.
6. Be sure pressure gauge is in correct place on discharge nozzle or discharge pipe.

V - D. PUMP WORKS A WHILE AND THEN QUILTS

1. Leaky suction line.
2. Stuffing box packing worn — or liquid seal plugged — allowing leakage of air into pump casing.
3. Air pocket in suction line.
4. Not enough suction head for hot or volatile liquids. Check carefully as this is a frequent cause of trouble on such service.
5. Air or gases in liquid.
6. Suction lift too high (suction pipe may be too small or long, causing excessive friction loss). Check with vacuum or compound gauge.
7. Impeller plugged.
8. Obstruction in suction or discharge line.
9. Casing gaskets damaged.

V - E. PUMP TAKES TOO MUCH POWER

1. Speed too high.
2. Head lower than rating, pumps too much liquid.
3. Liquid heavier than anticipated. Check viscosity and specific gravity.

* When directly connected to electric motors, check whether motor wiring is correct and receives full voltage. When directly connected to steam turbines, make sure that turbine receives full steam pressure.

4. Mechanical defects:
 - Shaft bent
 - Rotating element binds
 - Stuffing box too tight
 - Impeller clearance too great
5. Wrong direction of rotation, or impeller installed backwards.

V - F. PUMP LEAKS EXCESSIVELY AT STUFFING BOX

1. Packing is worn or not properly lubricated.
2. Packing is incorrectly inserted or not properly run in.
3. Packing is not correct for liquid handled.
4. Shaft sleeve scored.
5. Insufficient packing.
6. Damaged mechanical seal.

V - G. PUMP IS NOISY OR VIBRATES

1. Hydraulic noise — cavitation, suction lift too high. Check with vacuum or compound gauge.
2. Mechanical defects:
 - Shaft bent
 - Rotating parts bind, are loose or broken
 - Bearings worn out.
 - Coupling misaligned.

V - H. HIGH BEARING TEMPERATURE

See Section VI-A

1. Pump and driver misalignment.
2. Pump capacity too low.
3. Improper lubrication.
4. Excessive vibration.
5. Bent shaft.
6. Rotating element binds.

SECTION VI — CARE AND MAINTENANCE OF BEARINGS

VI - A. BEARING TEMPERATURES

All bearings operate at some temperature above that of the surrounding atmosphere, unless cooled. Heat is generated within the bearing due to rolling friction, churning of oil and the "drag" of the race.

Do not use the human hand as a thermometer. A temperature which feels "hot" varies from 120°F. - 130°F. depending upon the individual. Above this temperature, the human hand is worthless in estimating temperature.

Bearing temperatures up to 180°F are normal. Determine the temperature accurately by placing a contact type thermometer against the bearing housing. It should be recorded in a convenient location for reference. **THE STABILITY OF THE TEMPERATURE, RATHER THAN THE NUMBER OF DEGREES, IS THE BEST INDICATION OF NORMAL OPERATION.** A sudden increase in temperature is an indication of danger and a signal to investigate. The unit should be checked for abnormal hydraulic operation and unnecessary loads, such as coupling misalignment, etc.

VI - B. BEARING INSPECTION

1. *Ball and Roller Bearings*

Ball and roller bearings can be checked for visible wear by slowly turning the races and watching for pits or worn areas on the balls, rollers or raceways. The bearings can also be inspected by holding the inner race and spinning the outer race. If any rasping noises are emitted or the bearing "catches", it should be replaced. If any wear on the races is apparent, replacement is suggested.

2. *Sleeve Bearings*

Sleeve bearings should be inspected to determine if any deep scratches or gouges (other than oil grooves) are present. The babbitted surfaces should also be free of high or low spots. Unless these surfaces are completely smooth, they should be replaced if they cannot be "scraped in."

VI - C. CLEANING OF BEARINGS

The life of a bearing can be drastically reduced if contaminated with even a small amount of dust or dirt. All bearing assembly operations should be done in as dust-free an atmosphere as possible. All tools, as well as the hands, should be kept clean.

If new bearings are to be installed, they should not be unwrapped until ready for installation and should not be cleaned or washed.

If old bearings are dirty, they should be replaced. Washing the bearings does not guarantee cleanliness and is risky at best. If new bearings are not readily available, and immediate reassembly is necessary, dirty bearings can be cleaned as follows:

Pour one or two quarts of **CLEAN, WATER-FREE kerosene** into a **CLEAN** pail. Dip the bearings into the kerosene and agitate slowly. Repeat until bearing is completely clean. Blow dry with **CLEAN FILTERED** compressed air. With ball bearings, hold the two races together, but allow the inner race to rotate a few turns now and then to dislodge the kerosene from the retainer pockets. When the bearing has been blown dry, oil it immediately with a good grade of clean machine oil to prevent corrosion or rust.

If there is any question as to the condition of bearings, it is always best to replace them. This may prevent an unplanned shutdown.

VI - D. BEARING REMOVAL

1. *Ball Bearings*

A puller such as the one shown in Fig. 29 should be used. The puller bar must be "square" with the end of the shaft at all times in order to keep even pressure on the outer circumference of the bearing. The puller screw should be tightened steadily to enable the bearing to slide smoothly off the shaft. Do not damage the end of the shaft.

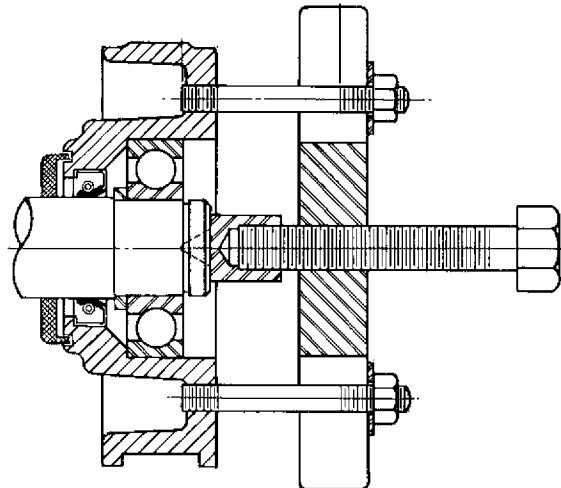

Figure 29

244-95

On some units, the bearing housings slide off the bearings and the puller such as the one shown in Fig. 30 should be used. This type of puller pulls directly against the bearing itself. The puller bar must be "square" with the end of the shaft at all times and the puller screw should be tightened steadily to enable the bearings to slide smoothly off the shaft. Do not damage the end of the shaft.

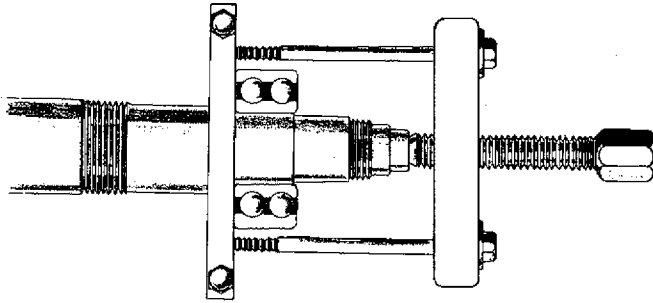

Figure 30

2. Sleeve Bearings

After the bearing shells have been removed, a bearing puller, such as shown in Fig. 30 should be used to remove the ball bearing. The puller bar must be "square" with the end of the shaft at all times and the puller screw should be tightened steadily to enable the bearing to slide smoothly off the shaft. Do not damage the end of the shaft.

After the bearings have been removed, they should be wrapped in clean paper or cloth to prevent contamination. Other parts which surround the bearings, such as bearing housings, should be kept clean in the same manner.

VI - E. BALL BEARING INSTALLATION

A film of clean machine oil should be applied to the bearing seat on the shaft. The bearing should be started on the shaft by tapping the inner race with a hammer or mallet. Do not use a lead mallet. The bearing must be kept "square" at all times. Once the bearing is located on the shaft, a driving sleeve, such as the one shown in Fig. 31 should be used. The sleeve should contact the inner race of the bearing only. The bearing should be pressed or driven until it contacts shoulder "x".

Duplex thrust bearings must be mounted in the proper position as described in Section VIII-F.

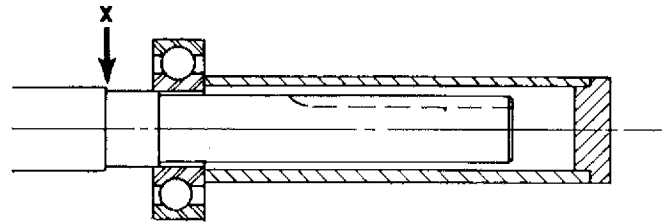

Figure 31

244-95

SECTION VII — ORDERING OF SPARE PARTS

VII - A. SPARE PARTS

To insure against possible long and costly "down-time" periods, especially on critical services, it is advisable to have spare parts on hand.

The most desirable parts to have on hand are the following:

1. *Horizontally Split Case Pumps*
 - a) "Rotating element". This is a group of assembled parts, including bearings, bearing housings, shaft, impeller(s), wearing rings, stuffing box bushings, and all rotating parts except the coupling.
 - b) Stuffing box packing (if any) — one set for each stuffing box.
 - c) Stuffing box gland packing (if any) — one set for each gland.
 - d) Mechanical Seals (if any) — one seal for each stuffing box.
2. *Frame Mounted End Suction Pumps*
 - a) "Support Head". This is a group of assembled parts which includes all parts except the casing, suction cover and coupling. The impeller is not mounted on the shaft.
 - b) Stuffing box packing (if any) — one set.
 - c) Stuffing box gland packing (if any) — one set.
 - d) Mechanical seal (if any) — one.
3. *"Back Pull-Out" End Suction Pumps*
 - a) "Back Pull-Out assembly". This is a group of assembled parts which includes all parts except the casing and the coupling.
 - b) Stuffing box packing (if any) — one set.
 - c) Stuffing box gland packing (if any) — one set.
 - d) Mechanical seal (if any) — one.

With these parts on hand, pump can be easily and quickly reconditioned by replacing the worn parts.

An alternate, though not as desirable as that stated above, is to have on hand parts that are most likely to wear and which can be used as needed.

Following is a list of these suggested parts:

1. Stuffing box packing (if any) — one set for each stuffing box.

2. Stuffing box gland packing (if any) — one set.
3. Mechanical seal (if any).
4. Shaft sleeve (if any).
5. Ball bearings — one of each.
6. Shaft nut (if any).
7. Bearing locknut and washer (if any).
8. Wearing rings (if any).
9. Shaft — one required.
10. Impeller key (if any).
11. Stuffing box bushings (if any).

If it is not convenient or desirable to carry the spare parts listed above, the following list is suggested as a minimum for servicing the pump under ordinary conditions of wear:

1. Stuffing box packing (if any) — one set for each stuffing box.
2. Stuffing box gland packing (if any) — one set.
3. Shaft sleeve (if any).
4. Ball bearings — one of each.
5. Shaft nut (if any).
6. Bearing locknut and washer (if any)

VII - B. INSTRUCTIONS FOR ORDERING SPARE PARTS

Repair orders will be handled with the minimum of delay if the following directions are followed:

1. Give Model No., size of the pump and serial number. These can all be obtained from the nameplate.
2. Write plainly the names, part numbers and materials of the parts required. These names and numbers should agree with those on the Sectional View in Section VIII-D.
3. Give the number of parts required.
4. Give complete shipping instructions.

MODEL 3934

SECTION VIII — MAINTENANCE

Model 3934 pumps are multistage pumps close coupled to the driving motor. Instructions for close coupled pump installation apply. Oil lubricated pumps must be installed in a horizontal position.

Be sure to allow for expansion at the pump foot, as directed on the tag affixed to the pump.

VIII - A. LUBRICATION

1. J Frame

J frame pumps have a greased for life ball bearing. No additional lubrication is required.

2. T & S Frames

T & S frame pumps have ball bearings which are greased at the factory. Bearings should be regreased every 2000 - 3000 hours (3 - 4 months). To regrease bearings:

- a. Remove plug on top of bearing frame. Screw in grease fitting shipped in the box of fittings that came with pump.
- b. Add grease while turning shaft by hand until old grease is forced out of grease relief fitting, and fresh grease appears.
- c. Remove grease fitting and reinstall plug.

3. M, L, X, and Y Frames

M, L, X, and Y frame pumps have flood oil lubricated bearings. **THE BEARINGS ARE NOT LUBRICATED AT THE FACTORY.**

A constant level oiler, #5 Trico, is packed with the pump. The oiler was adjusted to maintain proper oil level before leaving the factory. If adjustment is lost reset according to Fig. #1.

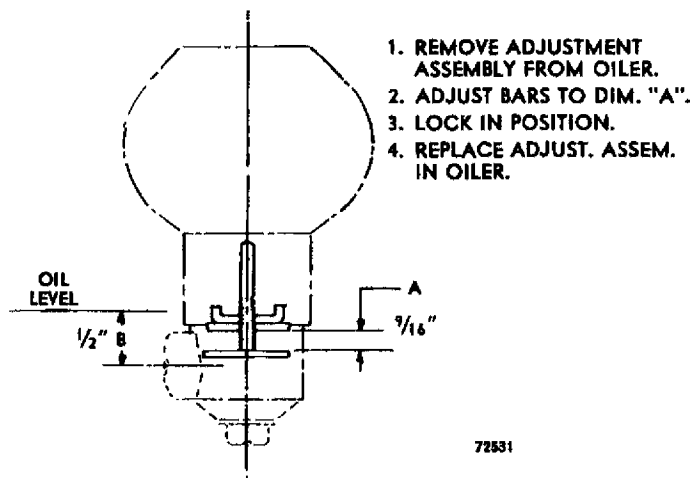

Fig. 1

Remove the 1/4" plastic plug from the 2" pipe plug on left side of frame (viewed from the motor end of pump). Thread the 1/4" elbow-nipple assembly into the tapped opening from which the plastic plug is removed. Thread the lower reservoir on the 1/4" elbow-nipple assembly so the oiler lower reservoir is vertical. (Should you wish to put the oiler on the right side of the pump, viewed from motor end of pump, move 2" plug with 1/4" tapped hole to right side and assemble as above.)

Check oil level adjustment setting. Fill bearing reservoir using the bottle. Several fillings will be required. Maintain oil in bottles at all times. Never fill the frame through the frame breather located on the top of the frame or through the oiler without use of the bottle.

On pump start up remove the breather. If oil is thrown out of the breather hole, lower oil level (A) 1/16". Oil viewed through the breather hole should be a mist and not be thrown out of the frame. Replace breather.

VIII - B. IMPELLER CLEARANCE ADJUSTMENT

There is no external impeller adjustment on the Model 3934.

VIII - C. DISASSEMBLY OF PUMP

1. Shut off valves controlling flow to and from pump. Disconnect piping.
2. Drain pump through plug (408A) in bottom of casing adapter (108).
3. If pump is oil lubricated, drain oil through oil drain plug on bottom side of bearing frame (228A).
4. Unbolt and remove motor from frame (228 or 228A).
5. Loosen set screw in coupling hub (233) and remove hub and key (400) from stub shaft assembly (380).
6. Loosen bolt (371U) so that discharge head (152) can turn in pump foot (131). Do not remove pump foot at this time.
7. Push a heavy bar or pipe through frame, being careful not to let the bar bear against the stub shaft assembly. Place a wrench on the discharge

head. Unscrew the discharge head until casing (100) is loose. Threads are right hand. Do not completely unscrew casing.

8. Set pump in a vertical position, resting on the frame. Remove discharge head and pump foot. Unscrew and remove casing from casing adapter (108). The casing must be removed vertically so that the pump shaft is not bent. The *total* overhead clearance required will be the total pump length less motor, plus the length of the casing.
9. Slide diffusers (150) and impellers (101) off pump shaft (122). Note last discharge diffuser (first diffuser removed) has no impeller. Also note that some pumps may have diffuser blanks (150A) substituted for some of the stages, which must be removed before the diffusers are removed. Note suction diffuser (151) which is the last diffuser removed is different than the others. Be careful not to bend shaft.
10. Unbolt and remove casing adapter from seal housing (159).
11. If pump has standard mechanical seal, pump shaft with rotary seal assembly (383A) can be removed. If double, tandem or special cooled seal is used, seal seat mount (158) must be removed first.
12. Remove seal from shaft only if it is to be replaced.
13. Remove seal seat mount.
14. Unbolt and remove seal housing from bearing frame.
15. Unbolt and remove thrust bearing end cover (109 or 109A). (On J frame thrust bearing cover is not used. Remove retaining ring (361E)).
16. Remove stub shaft assembly from bearing frame.
17. Remove thrust bearing lock nut (136). (J frame does not have lock nut.)
18. Remove ball bearings (112 or 112A and 168A) using a bearing puller as shown in Section V-D, Fig. #29. Care must be taken to prevent damage to bearings. Never use a hammer to drive shaft through bearings. Protect bearings from contamination.

VIII - D. SECTIONAL VIEW, PARTS LIST, CONSTRUCTION DETAILS AND PRESSURE-TEMPERATURE CAPABILITY (See Pgs. 4A & 5A)

VIII - E. INSPECTION AND OVERHAUL

1. *O-rings* — Inspect and replace if damaged.
2. *Shafts* — Check shafts for runout to be sure they are not bent. Bearing seats, retaining ring grooves, keyways, surfaces under oil seals, and surface under mechanical seal should be in good condition. Replace shafts if necessary.
3. *Mechanical Seal* — replace if faces are worn, scarred or cracked, or if rubber bellows is damaged.
4. *Thrust Washers* — Inspect and replace if worn. Eye thrust washer (547) and ring thrust washer (548) are nominal 1/16 inch thick, replace if worn to less than 0.050 inch. Back thrust washer (546) is nominal 1/32 inch thick, replace if worn to less than 0.020 inch.
5. *Oil Seal* — Replace if worn or damaged.
6. *General* — All parts should be clean and free of burrs before assembly. This is especially important at o-ring grooves, threads and bearing areas.

VIII - F. REASSEMBLY OF PUMP

1. Install ball bearings (112 or 112A and 168A) on stub shaft (380). Use procedure described in Section VI - E, page 19. J frame — uses one deep groove sealed for life bearing which can be installed in either direction. S frame — uses a matched pair of angular contact (duplex) bearings. Bearings should be mounted face to face (thin edges of outer races facing each other). M frame — uses one deep groove radial bearing and one angular contact thrust bearing. The radial bearing has both edges of the outer race the same thickness, and is mounted furthest from the motor. The thrust bearing should be mounted so that the thin edge of the outer race faces the radial bearing. A bearing spacer (443) should be installed between the bearings. L, X, and Y frame — uses one deep groove radial bearing and a matched pair of angular contact (duplex) bearings. The radial bearing has both edges of the outer race the same thickness, and is mounted furthest from the motor. The two thrust bearings should be mounted so that the thin edges of the outer races face the radial bearing. A bearing spacer (443) should be installed between the radial and thrust bearings. On Y frame only, install deflector (123).
2. Screw thrust bearing lock nut (136) on stub shaft and tighten firmly. (J frame does not have a lock nut.)

3. Be sure wave washer (529) is in position in bearing frame (228 or 228A). (J frame does not have a wave washer.)
4. Slide stub shaft and bearings into bearing frame.
5. Bolt thrust bearing end cover (109A) to bearing frame. Be sure gasket (360) is in place. (J frame does not have a thrust bearing cover. Install retaining ring (361E) in bearing frame with tapered side of ring away from bearing.)
6. Bolt seal housing (159) to bearing frame.
7. Install o-rings (412L) on seal seat mount (158). Lubricate o-rings well, and press seal seat mount into seal housing.
8. Install o-ring on stationary seat of mechanical seal (383B). Lubricate o-ring well, and press stationary seat into seal seat mount.
9. Install retaining rings shaft (361) (2 rings) in grooves on pump shaft (122). (BP 20 pumps, 5/8" diameter shaft under seal, have only one ring.)
10. Slide rotary unit of mechanical seal (383A) over splined end of pump shaft and against retaining ring. Use care to avoid cutting rubber bellows on spline teeth. (BP 20 pump, 5/8" diameter shaft under seal, seal rests against shoulder on shaft.)
11. Set bearing frame in a vertical position, motor end down.
12. Slide splined end of pump shaft into splined end of stub shaft. Push pump shaft down until it bottoms.
13. Bolt casing adapter (108) to seal housing. Be sure o-ring (412K) is in place.
14. Install impeller key (178) in shaft.
15. Slide suction diffuser (151) on shaft. Note suction diffuser is of different design than other diffusers. Also note all diffusers are machined for O-rings, but an O-ring should be installed only on every 16th diffuser on BP 20, and every 8th diffuser on all other sizes.
16. Slide first stage impeller (100) on shaft. Note first stage impeller does not have a thrust washer, eye (547).
17. Continue adding diffusers (150) and impellers until correct number have been added. Be sure male and female lock fits on diffusers are engaged. Last diffuser does not have an impeller.
18. Add diffuser blanks (150A) if pump was supplied with them.
19. Screw casing (100) on casing adapter.
20. Screw discharge head (152) into casing. Be sure o-ring is in place.
21. Put pump foot (131) on discharge head. Tighten bolt (371U) finger tight.
22. Lay pump in horizontal position. Place heavy bar or pipe through bearing frame to hold frame. Do not allow bar to contact shaft. Tighten discharge head as tight as possible.
23. Plug unused openings in seal housing. Openings are required only for special seals.
24. Tap coupling hub (233) on shaft.
25. Bolt motor to bearing frame.
26. Pump is now ready to reinstall. Follow applicable installation, lubrication and startup procedures.

VIII - G. BEARING AND SEAL REPLACEMENT

Motor, bearing frame and seal housing can be unbolted and removed without disassembling the liquid end, when only the ball bearings and/or mechanical seal require service. Refer to applicable steps in sections VIII C, D, E & F.

VIII - D. SECTIONAL VIEW, PARTS LIST, CONSTRUCTION DETAILS AND PRESSURE-TEMPERATURE CAPABILITY

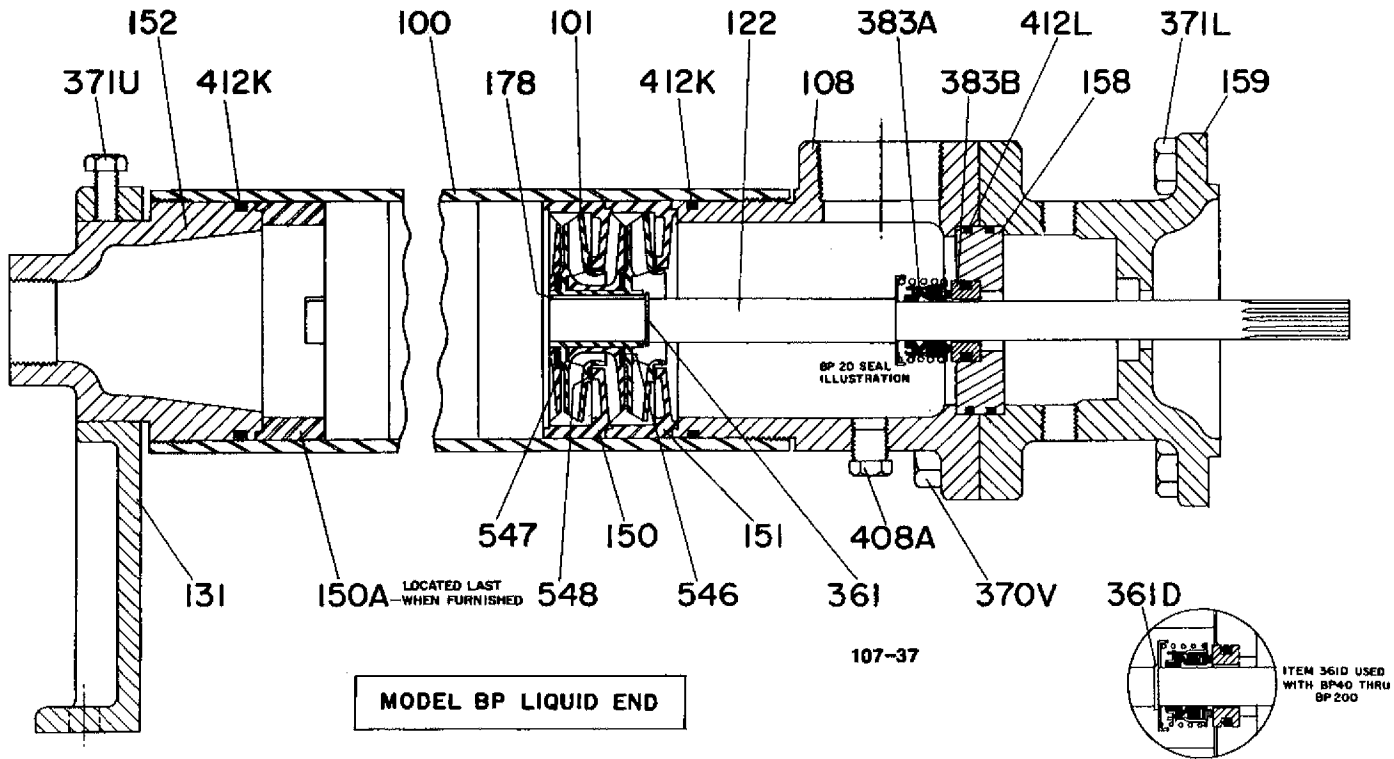

MODEL BP LIQUID END

BILL OF MATERIALS

MODEL 3934 - BP

LIQUID END

COOLING JACKET - OPTIONAL

ITEM NO	PART NAME ● - OPTIONAL	MATERIAL
100	CASING	STEEL TUBE C1025
101	IMPELLER	NI-RESIST TYPE 1
108	CASE ADAPTER	NI-RESIST TYPE 2
122	SHAFT	K-MONEL
150	DIFFUSER	NI-RESIST TYPE 1
150A	DIFFUSER BLANK	NI-RESIST TYPE 2
151	SUCTION DIFFUSER	NI-RESIST TYPE 1
152	DISCHARGE HEAD	NI-RESIST TYPE 2
158	STA SEAT MOUNT	NI-RESIST TYPE 2
159	SEAL HOUSING	NI-RESIST TYPE 2
178	IMPELLER KEY	MONEL ALLOY 400
188 ●	COOLING JACKET	NI-RESIST TYPE 2
361	RETAINING RING, SHFT	AISI 303SS
361D ●	RETAINING RING, MECH SEAL	AISI 303SS
370V	H CAP SCREW-ADPTR TO SEAL HSG	STEEL A307B
371L	H CAP SCREW-SEAL HSG TO FRAME	STEEL A307B
383A	ROTATING ELEMENT	316SS-VITON
383B	STATIONARY SEAT (XP171)	NI-RESIST & VITON
383B	STATIONARY SEAT (XP1D1)	CARBIDE & VITON
408A	PIPE PLUG - DRAIN	FREE CUTTING BRASS ROD
412J ●	O-RING COOLING JKT	BUNA-N
412K	O-RING CASING	VITON
412L	O-RING - STAT SEAT	VITON
473 ●	RESTRICTING BUSHING (COOLING JACKET)	CARBON
546	WASHER - BACK	GLASS-MOLY-TEFLON
547	WASHER - EYE	GLASS-MOLY-TEFLON
548	WASHER - RING	GLASS-MOLY-TEFLON

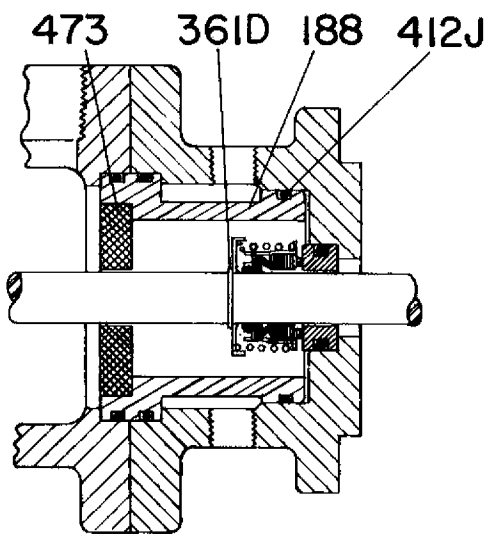

Pressure-Temperature Capability

Pressure Limits:
 Working Pressure: 1500 PSI Max.
 Suction Pressure: 400 PSI Max.

Temperature Limits (Lubricating Fluids):
 W/O Cooling:
 J & S Frame Pumps (grease lube) 250° F.
 Oil Lube Pumps 300° F.
 W/Cooling: 400° F.

Temperature Limits (Water and Other Non-Lubricating Fluids): 250° F.

BILL OF MATERIAL

MODEL 3934 - BP

WHERE USED

FRAME PARTS

ITEM NO	PART NAME	MATERIAL	J	S	M	L	X	Y
			GREASE LUBRICATION		OIL LUBRICATION			
109	BEARING END COVER	CI-A48	-	S	-	-	-	-
109A	BEARING END COVER	CI-A48	-	-	M	L	X	Y
112	BALL BEARING THR	STEEL	MRC3D8SZZ	MRC73D8POF	-	-	-	-
112A	BALL BEARING THR	STEEL	-	-	MRC7408DB	MRC7408DB	MRC7408DB	MRC7313DB
113	GRS RELIEF FITTING	STEEL/CAD PLATE	-	S	-	-	-	-
113A	BREATHER	STEEL/ZINCPLATE	-	-	M	L	X	Y
123	DEFLECTOR	LAM PLASTIC	-	-	-	-	-	-
131	PUMP FOOT (BP 20) ONLY	CI-A48	J	S	M	L	X	Y
131	PUMP FOOT (EXCEPT BP 20)	CI-A48	-	S	M	L	X	Y
136	BRG LOCK NUT	STEEL	-	S	-	-	-	-
168A	BALL BRG CPLG	STEEL	-	-	MRC408S	MRC408S	MRC408S	MRC313S
193	GREASE FITTING	STEEL/ZINCPLATE	-	S	-	-	-	-
228	FRAME - GREASE	CI-A48	J	-	-	-	-	-
228A	FRAME - OIL	CI-A48	-	-	M	L	X	Y
232	CPLG HUB - MOTOR	DIE METAL	J	S	M	L	X	Y
233	CPLG HUB - PUMP	DIE METAL	J	S	M	L	X	Y
235	COUPLING SLEEVE	RUBBER	J	S	M	L	X	Y
251	SIGHT GLER	WHITE MTL/GLASS	-	-	M	L	X	Y
332	GREASE SEAL - BRG COVER	BUNA-N	-	S	-	-	-	-
332A	OIL SEAL - BRG COVER	BUNA-N	-	-	M	L	X	Y
333	GREASE SEAL - FRAME	BUNA-N	-	S	-	-	-	-
333D	OIL SEAL - FRAME	BUNA-N	-	-	M	L	X	Y
360	GASKET END COVER	VELLUMOID	-	S	M	L	X	Y
361E	RETAINING RING - BRG	STEEL C1075	J	-	-	-	-	-
370N	H CAP SCREW-END COVER	STEEL A307B	-	S	M	L	X	Y
371	H CAP SCREW-FR TO MOTOR	STEEL A307B	J	S	M	L	X	Y
371U	H CAP SCREW-PUMP FT RTNG	STEEL A307B	J	S	M	L	X	Y
380	STUB SHAFT ASSY	STEEL C1018	J	S	-	-	-	-
382	BRG LOCK WASHER	STEEL	-	-	-	-	-	-
389	MOTOR ADAPTER	CI-A48	-	-	-	-	-	-
400	COUPLING KEY	STEEL B1112	J	S	M	L	X	Y
443	BEARING SPACER	STEEL C1018	-	-	M	L	X	Y
529	WAVE WASHER	STEEL C1095	-	S	M	L	X	Y

Q - Y FRAME FOR 444 & 445 MOTORS ONLY

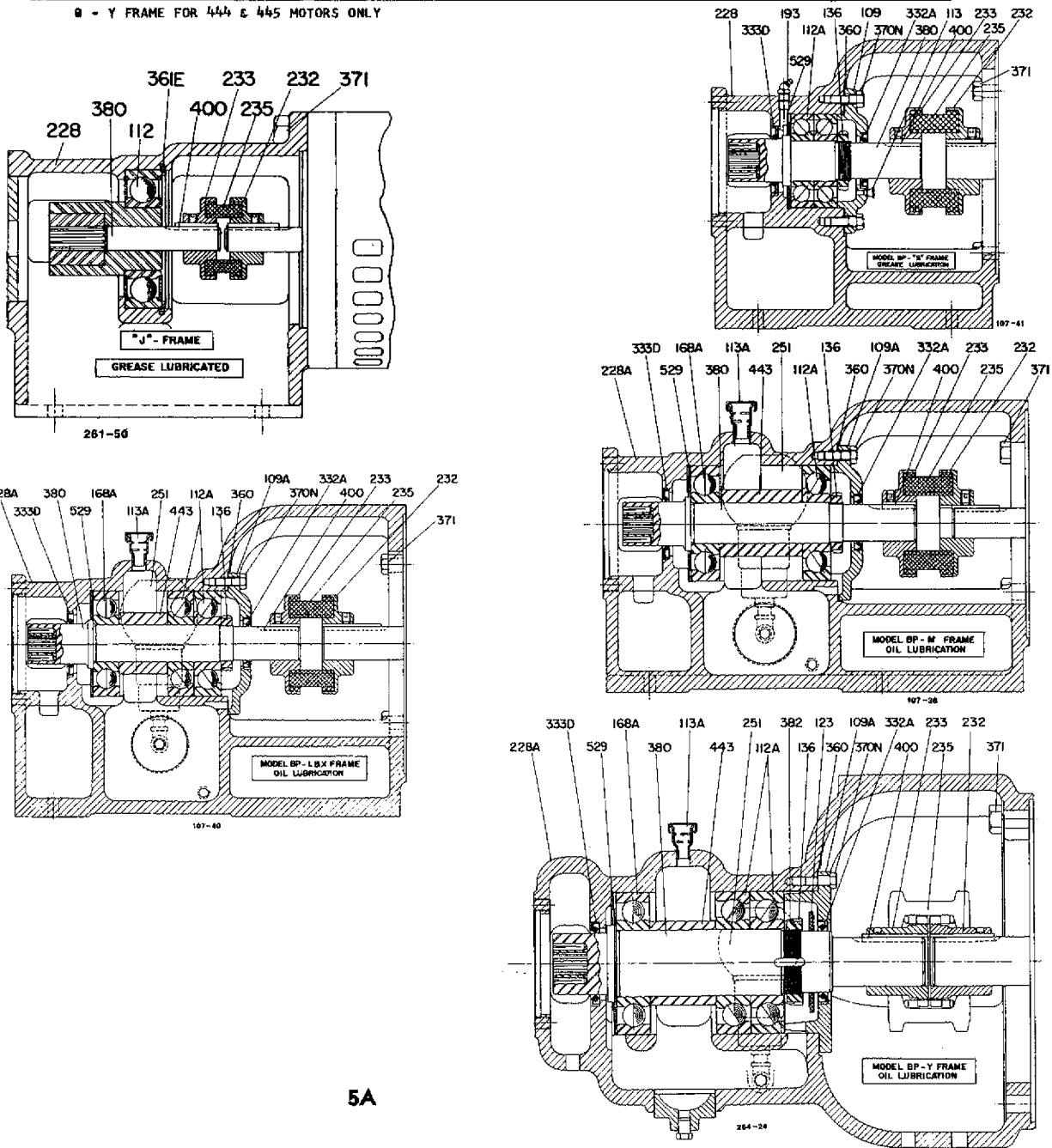

Changes and Additions

Model 3934 Instruction Manual (Form 9293-EL)

The Model 3934 has counter-clockwise rotation when viewed from the motor end. The motor should be checked for correct rotation before it is coupled to the pump.

VIII-A LUBRICATION

3. M, L, X, and Y frames. (This replaces paragraph 3 of Section VIII-A.)

M, L, X, and Y frame pumps have flood oil lubricated bearings.
THE BEARINGS ARE NOT LUBRICATED AT THE FACTORY.

A constant level oiler, #5 TRICO, is packed with the pump.

- a. Before installing the oiler on the bearing frame check the oiler adjustment. The setting dimension (9/16") is illustrated in the insert on Form 9322-EL.
- b. Remove the 1/4" plastic plug from the 2" pipe plug on the left side of the frame as viewed from the motor end of the pump.
- c. The nipple-elbow assembly is assembled finger tight at the factory. Before installing it on the pump, the threaded connections should be made up with pipe sealant.
- d. Install the nipple-elbow assembly so the long nipple (1/4" x 1-3/4") extends horizontally from the frame to the 90° elbow and the close nipple vertically from the elbow to the bottom connection of the oiler. Refer to Form 9322-EL for schematic drawing. Install the oiler reservoir. (See other side for Form 9322-EL.)
- e. Fill bearing reservoir using oiler bottle. Several fillings will be required. Maintain oil in bottle at all times. Never fill the frame through the frame breather located on the top of the frame or through the oiler without use of the bottle.
- f. On pump start-up remove the breather. Oil viewed through the breather hole should be a mist. If oil is thrown out the breather hole or an oil mist is not visible, recheck all dimensions shown on Form 9322-EL. (See other side for Form 9322-EL.)

NOTE: The oiler may be installed on the right side of the pump (viewed from the motor end) by moving the 2" plug with 1/4" tapped hole to right side and assembling as above.

- continued -

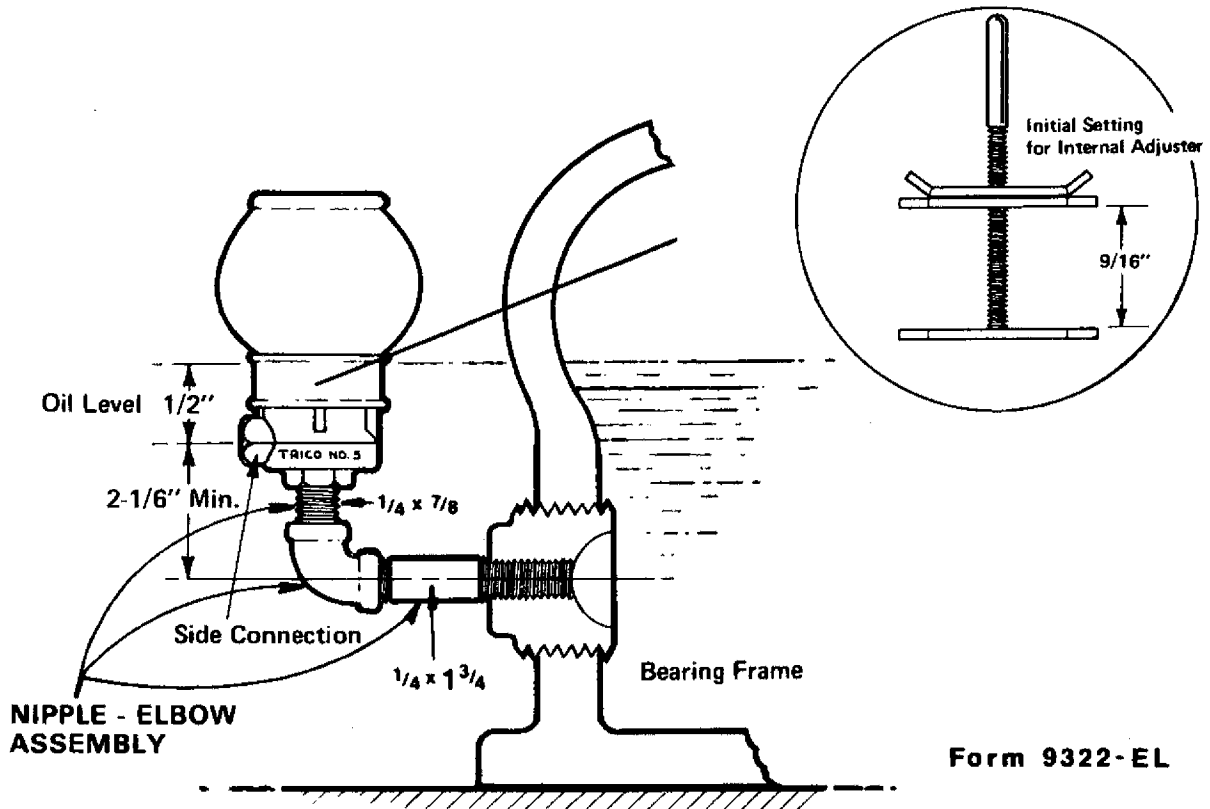

VIII-C. DISASSEMBLY OF PUMP

18. Change "Section V-D" in first sentence to read "Section VI-D".

VIII-F. REASSEMBLY OF PUMP

22. Delete sentence "Tighten discharge head as tight as possible."
 Add: The discharge head must be tightened to the following minimum torque values:

BP 20 Series	400 ft-lbs
BP 40, 70, 100, 200 Series	600 ft-lbs

VIII-D. PARTS LIST

Page 5A, Item 112A Ball Bearing Thrust

Change Thrust Bearing numbers as follows:

<u>FRAME</u>	<u>PRESENT BEARING</u>	<u>BEARING SHOULD BE</u>
M	7408 DB	MRC 7408 or equal
L	7408 DB	MRC 7408 DT or equal
X	7408 DB	MRC 7408 DT or equal
Y	7313 DB	MRC 7313 DT or equal

Nothing but pumps

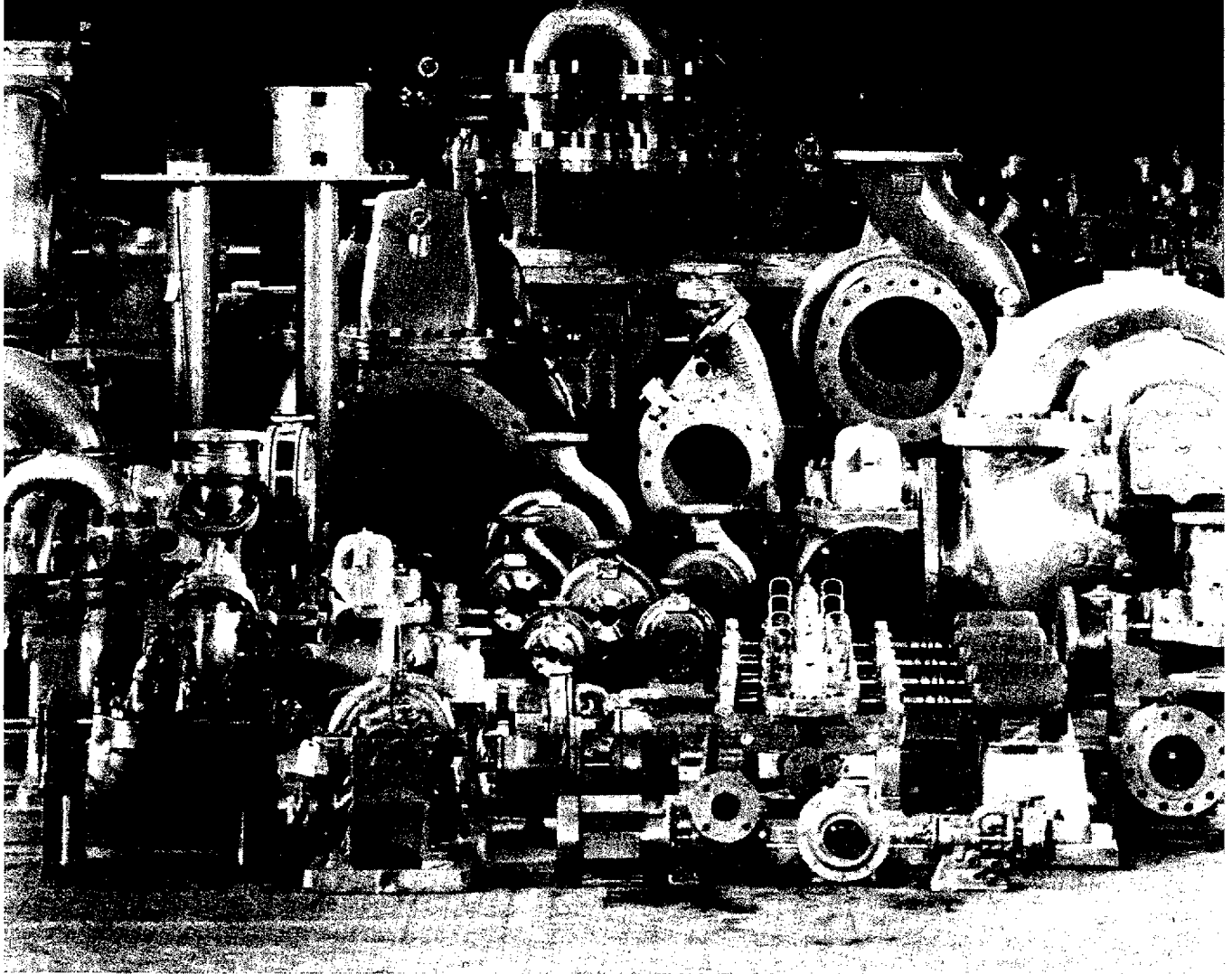

Branch Sales Offices

Atlanta—1760 Tully Circle, N.E., Atlanta, Georgia 30329
Baton Rouge—8506 Airway Drive, Baton Rouge, Louisiana 70805
Boston—209 W. Central St., Natick, Massachusetts 01750
Buffalo—2095 Kensington Ave., Buffalo, New York 14226
Charleston—54 MacCorkle Ave., S.W., St. Albans, West Virginia 25177
Charlotte—4705 Park Road, Charlotte, North Carolina 28209
Chicago—2459 Crescent Dr., Broadview, Illinois 60153
Cincinnati—6301 Wooster Pike, Suite D, Mariemont, Ohio 45227
Cleveland—24700 Center Ridge Road, Westlake, Ohio 44145
Dallas—P.O. Box No. 1332, Richardson, Texas 75080
Denver—300 East Hampden Ave., Suite 402, Englewood, Colo. 80110
Detroit—28437 Greenfield Road, Southfield, Michigan 48076
Houston—5830 Star Lane, Houston, Texas 77027
Jacksonville—P.O. Box 5038, Jacksonville, Florida 32207
Kansas City—207 Westport Road, Room 202, Kansas City, Missouri 64111
Los Angeles—3337 San Gabriel River Pkwy., Whittier, California 90601
Memphis—5050 Poplar Ave., Suite 700, Memphis, Tennessee 38157
Mobile—800 Downtowner Boulevard, Mobile, Alabama 36609
Monroe—205 S. Stanley St., Monroe, Louisiana 71201
New York—299 Fairfield Avenue, Fairfield, N.J. 07006
Philadelphia—4221 Ferns Blvd., Drexel Hill, Pennsylvania 19025
Pittsburgh—Two Parkway Center, Suite 117, Pittsburgh, Pa. 15229
St. Louis—1401 S. Brentwood Blvd., St. Louis, Missouri 63144
San Francisco—1043 Stuart St., LaFayette, California 94649

Tulsa—P.O. Box 45506, Tulsa, Oklahoma 74145
Wilmington—17 Polly Drummond Center, Newark, Delaware 19711
Pacific Northwest—Goulds Pumps Western, Inc.
P.O. Box 8768, Portland, Oregon 97208

International Sales Offices

Goulds Pumps Inc.—Export Dept., Seneca Falls, New York 13148
Canada—Bofort Goulds Div., Bofort Sorel Wainwiley Ltd., Quebec, Canada
Goulds Pumps (Asia) Private Ltd.—Room 1311-12, 51 Godhill Plaza, Singapore 11, Singapore
Goulds Pumps (Philippines) Inc.—P.O. Box 145, Commercial Center, Makati, Rizal D-708, P.I.
Goulds Pumps European Offices—
113 bis, Avenue Charles de Gaulle, F-92200 Neuilly-sur-Seine, France
Goulds Pumps Latin American Offices—Apartado Aereo 90316, Bogota, Colombia
Bombas Goulds de Mexico, S.A. de C.V.—Condor 96, Mexico 20, DF
Goulds Bombas e Equipamentos Ltda.—P.O. Box 3307, Sao Paulo, Brazil

Manufacturing Plants

Main Plant and Headquarters—Seneca Falls, New York 13148
Vertical Pump Division—City of Industry, California 91747
Vertical Pump Division—Lubbock, Texas 79417
Bombas Goulds de Mexico, S.A. de C.V.—Condor 86, Mexico 20, DF
Goulds Bombas e Equipamentos Ltda.—Cx. P. 91 Saito, Estado Sao Paulo, Brazil
Goulds Pumps (Philippines) Inc.—P.O. Box 145, Commercial Center, Makati, Rizal D-708, P.I.



ITT

Form I3934 2023-04

Main Plant and Headquarters, Seneca Falls, N.Y. 13148

Form 9293-EL Printed in U.S.A.