



GOULDS PUMPS

Enclosed Impeller / Single Stage / Close Coupled / End Suction
CENTRIFUGAL PUMPS

MODEL 3655

Capacity 5 to 3800 GPM
Head 15 to 400 Feet TDH
Temperatures To 250° F.
Working Pressure To 150 PSIG

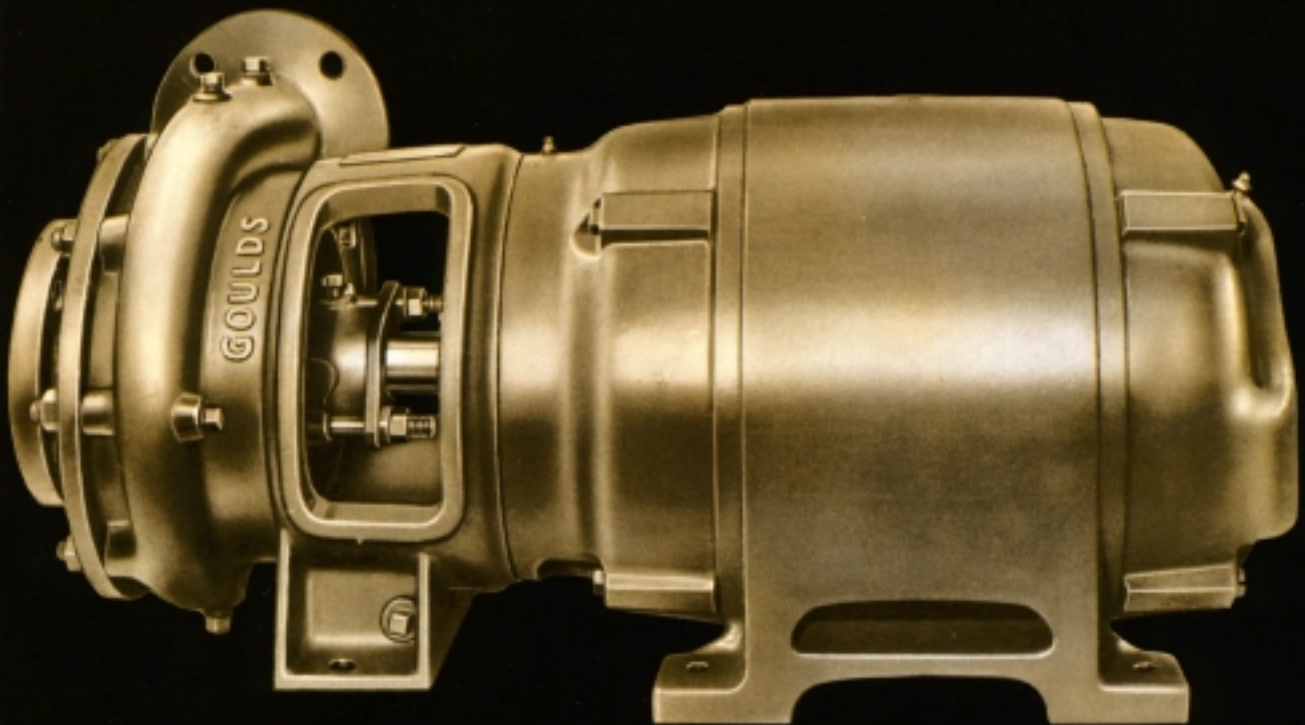

Model 3655

Pump and motor are combined in a single, complete, compact unit, easy to install and ready to run. Single shaft eliminates coupling and assures perfect and maintained alignment with freedom from vibration. Unit construction does away with bedplate to support pump and motor. Simplicity and strength of parts insure long life with minimum maintenance expense under most exacting and rigorous operating conditions.

Model 3655 Close-Coupled Pumps are complete units. Pump and motor are bolted together. Impeller is mounted on extended motor shaft.

- *Flexible couplings or bedplates not required*
- *Permanent alignment built in with machined male and female lock fits*
- *Compact*
- *Easily and quickly installed*
- *Mount vertically or horizontally*
- *Minimum attention*
- *Ideal for OEM Packages — deaerators, washers, etc.*

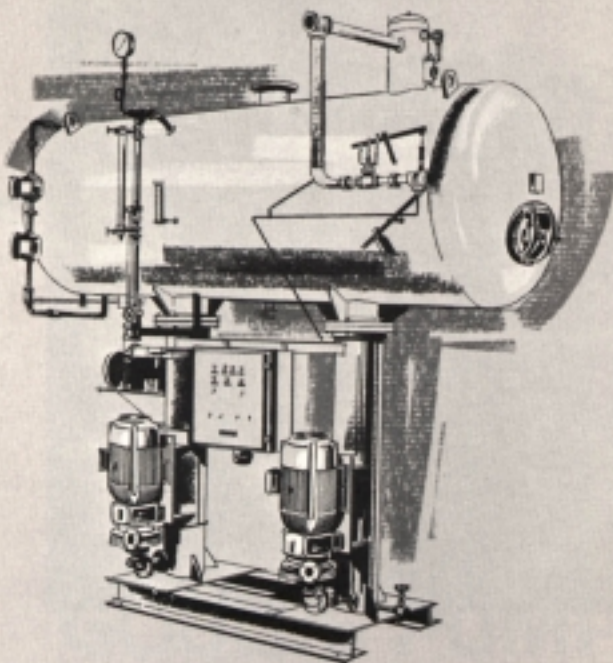

Design Features

VOLUTE CASING (Part 100). Casing is bolted to the adapter. A recessed lock fit between casing and adapter insures permanent alignment. The discharge nozzle can be swivelled to any of three positions for greater flexibility of application. (See dimension print, page 8). The separate suction cover is bolted to the casing through a machined lock joint. No stud or bolt holes are tapped through the casing to the liquid ways. Tapped openings are provided for priming, venting, draining, and for suction and discharge gauge connections. ASA 125 lb. flat face flanges standard on all sizes.

ENCLOSED IMPELLER (Part 101). One piece, single suction impellers are statically balanced to insure smooth operation. All, except some small sizes where end thrust is a minor factor, are also hydraulically balanced. The impeller is mounted directly on the extended motor shaft and is keyed to it. A self locking cap nut holds a compression seal washer securely against the impeller hub to prevent leakage of liquid between shaft sleeve and shaft.

RENEWABLE WEARING RINGS (Parts 103 & 127). Rings maintain proper running clearances to minimize leakage between suction and discharge sides. They can be replaced inexpensively when worn.

SHOULDERED SHAFT SLEEVE (Part 126). The sleeve is shouldered on the shaft near the impeller and covers the full length of the shaft to the motor



end bracket, as illustrated. It is sealed by compression between the impeller hub and the shoulder on the shaft to protect the shaft from contact with the liquid. The shaft sleeve is free to expand or contract with temperature changes.

INTEGRAL STUFFING BOX. Cast as a part of the casing, the box provides for five rings of die-formed packing plus the lantern ring. It has tapped openings for introduction of sealing liquids under pressure — from the pump casing, from an outside clear water supply, or from a lubricator using a lubricant which is non-solvent for the liquid being pumped.

WATER DEFLECTOR (Part 123). The deflector prevents leakage of liquid into the motor bearing, and is securely mounted on the end of the shaft sleeve with a machined recess.

It is drilled and tapped so that in servicing the pump it can be used, with a spanner, to prevent shaft rotation while removing or tightening the impeller nut. Also, when puller studs are attached, it can be used to remove the shaft sleeve.

THE ADAPTER (Part 108). A machined lock between the adapter and the motor end bracket keeps the adapter and casing in permanent alignment with the motor and extended motor shaft. The sides of the adapter are fully open for ready access to stuffing box and gland. A foot (under the adapter on groups "S" and "M", and under casing on group "L") provides support for overhung weight.

MECHANICAL SEALS. In place of stuffing box packing, Model 3655 can be furnished, on order, with a mechanical seal as illustrated. Also, mechanical seals may be substituted in the field with-



out remachining the stuffing box. When seals are used, a shaft sleeve of AISI 303 stainless steel is furnished on all constructions.

SPLIT GLAND (Part 107). The illustration shows how gland halves are held together with hollow washers which slip over bosses on the gland. *It is unnecessary to unbolt gland halves when repacking the stuffing box.* The gland is located at a 45° angle so that leakage will not drip on the gland bolts. Model 3655 can be supplied with a water quenched gland when ordered.



MOTOR. The motor is assembled as an integral part of the complete unit. Its end bracket is machined to match the recessed lock fit on the adapter to insure permanent alignment. Shaft carries impeller and sleeve. Motor ball bearings are designed to carry all radial and thrust loads, and are installed in sealed housings which retain lubricant and exclude dirt and moisture.

Motors regularly stocked are: (1) Drip protected type with splash proof bracket on pump end and drip proof bracket on outboard end. (2) Totally enclosed and polyphase explosion proof type built to meet Underwriters requirements for Class 1, Group D installations. Motors of special constructions are available on order.

ROTATION. All pumps are built for right hand rotation, i.e., clockwise when viewed from the motor end.

MATERIALS. Available in bronze fitted, bronze fitted with iron impeller, all iron, or all bronze. See page 5 for construction materials of all parts.

SECTIONAL VIEWS

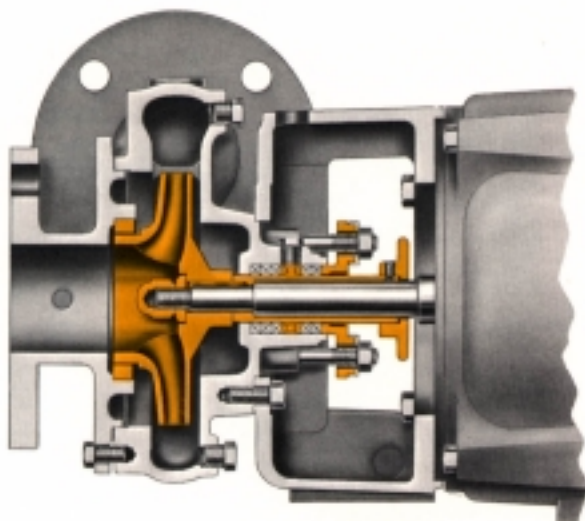
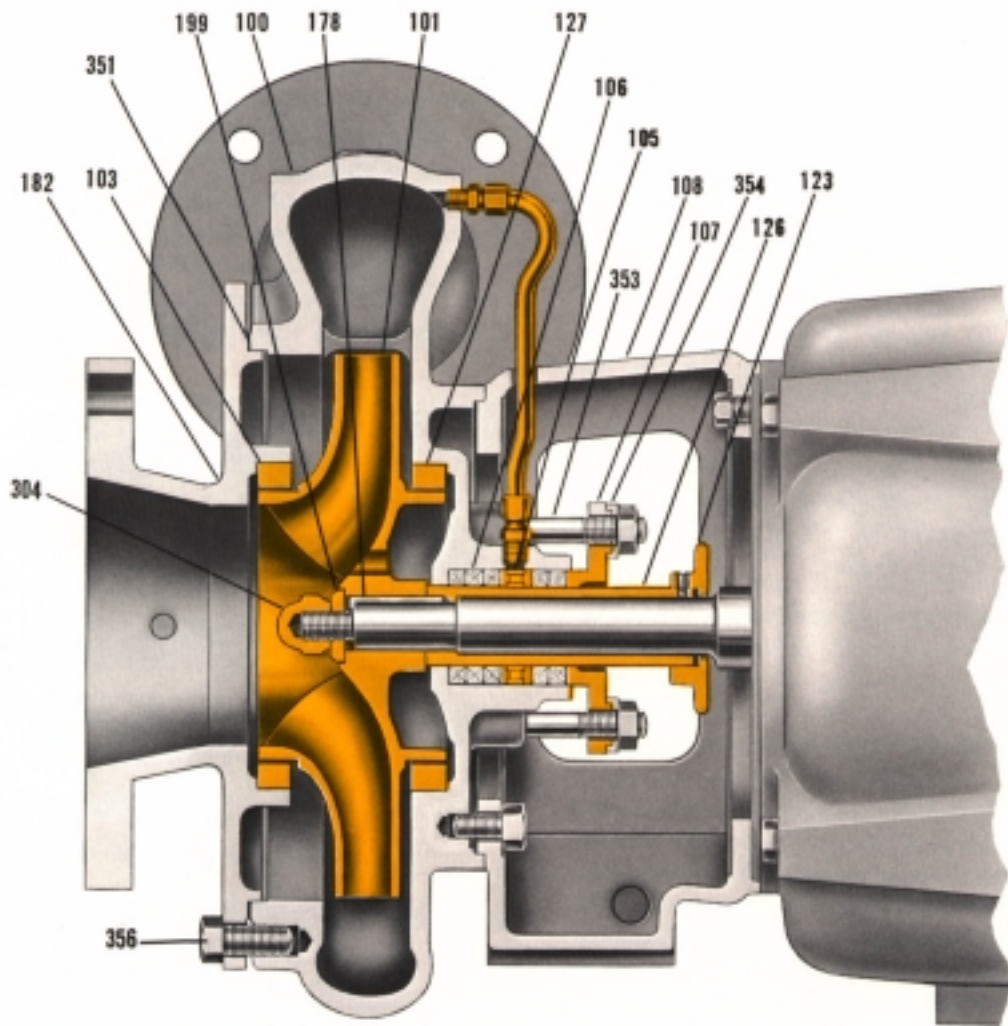

SIZES—with suction wearing ring only

$1\frac{1}{4} \times 1\frac{1}{2}$ —5, $1\frac{1}{4} \times 1\frac{1}{2}$ —7, $1\frac{1}{4} \times 1\frac{1}{2}$ —8,
 $1\frac{1}{2} \times 2$ —5, $2\frac{1}{2} \times 2\frac{1}{2}$ —6 and 4×4 —7.

All other sizes have two casing wearing rings as illustrated above.

COMPOSITE PERFORMANCE CURVES

GROUP "S" • 3500 RPM

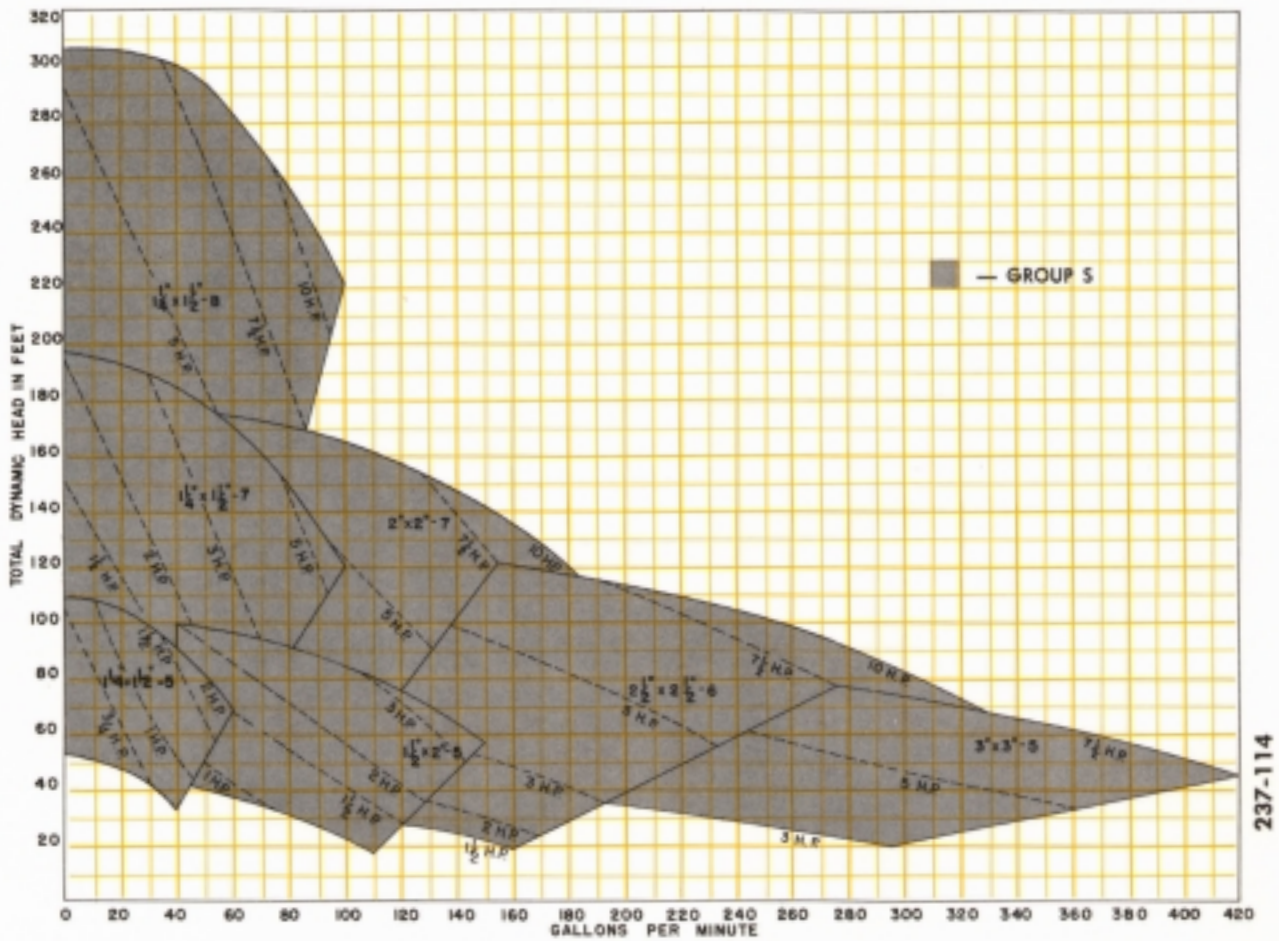

GROUP "M" • 3500 RPM

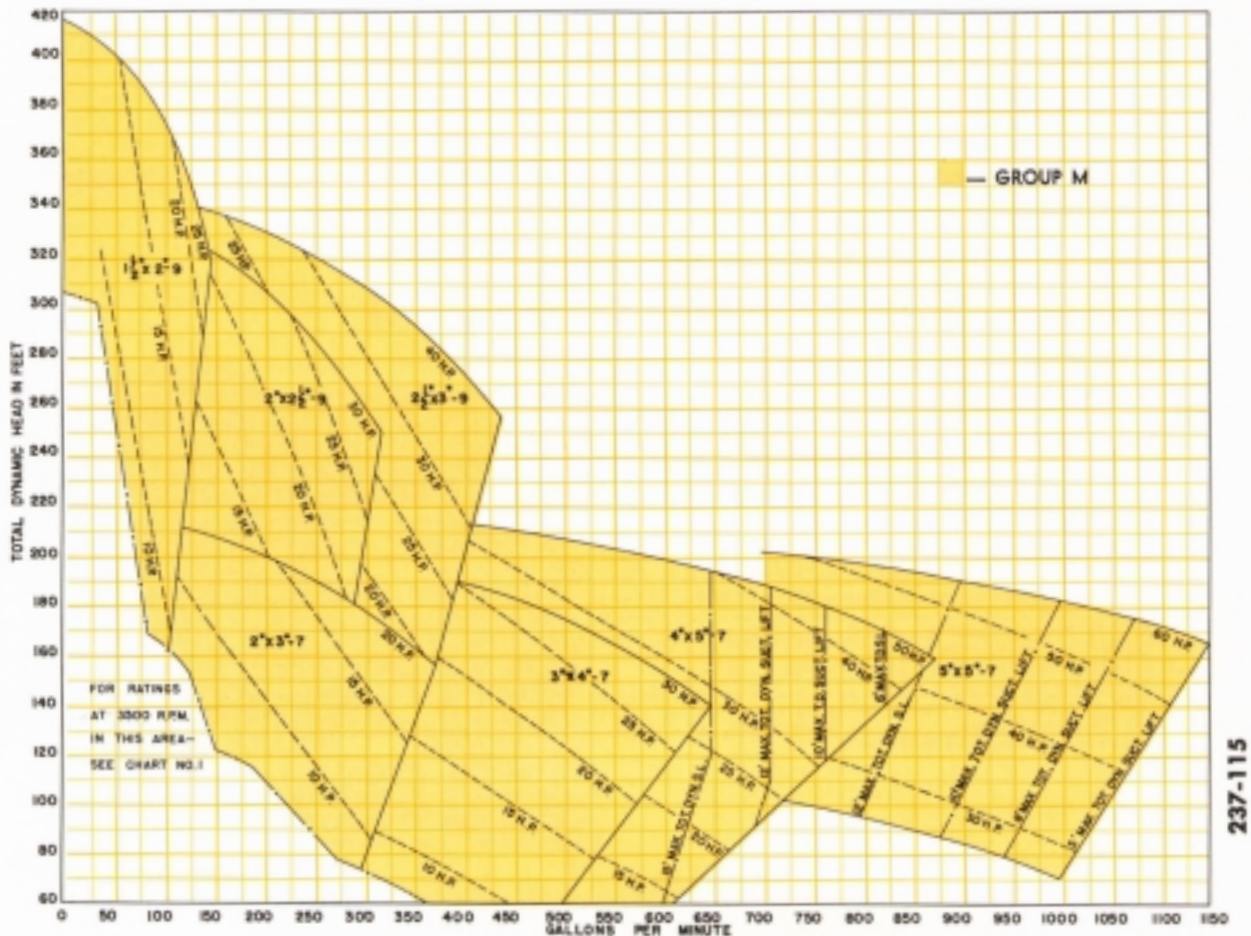

Ratings shown are suitable for 15 ft. suction lift when handling clear, cold water at sea level, except where otherwise noted.

COMPOSITE PERFORMANCE CURVES

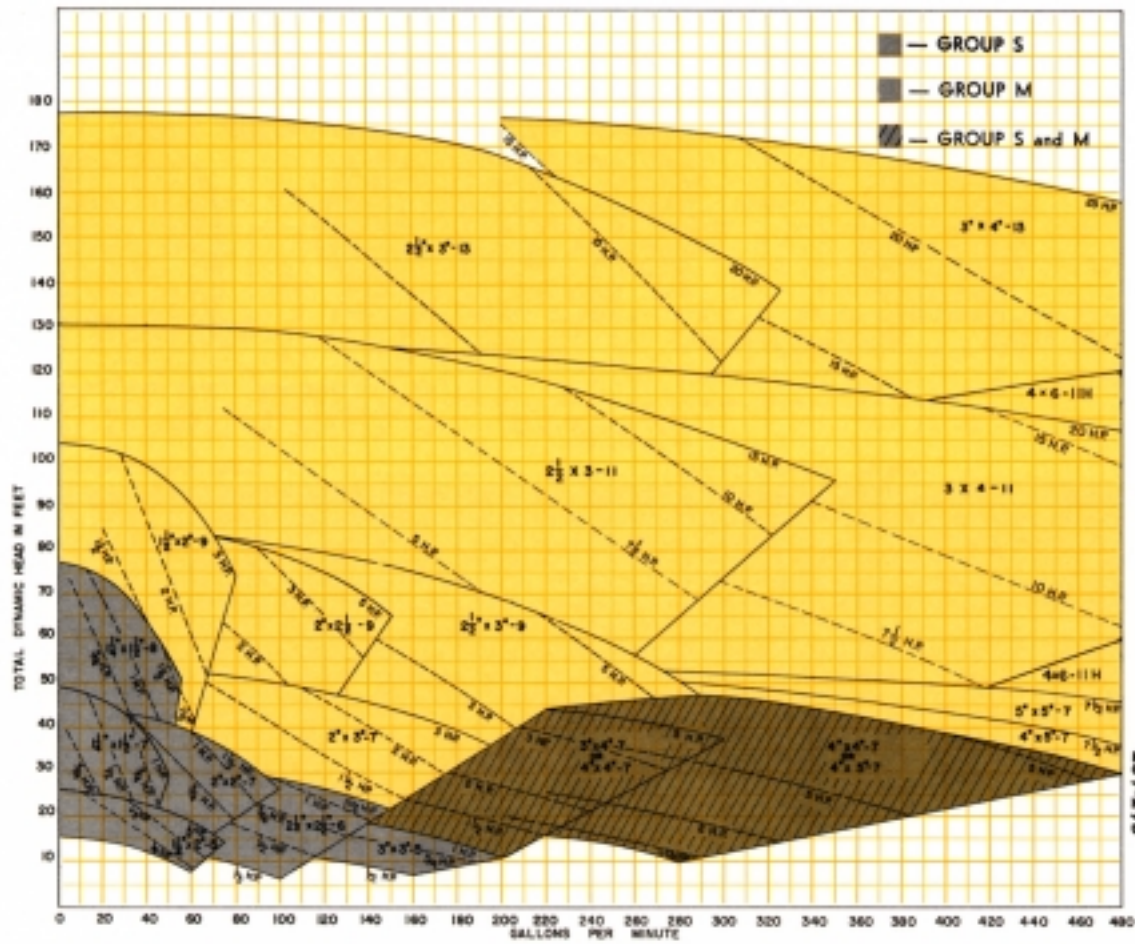

GROUP "S" & "M" • 1750 RPM

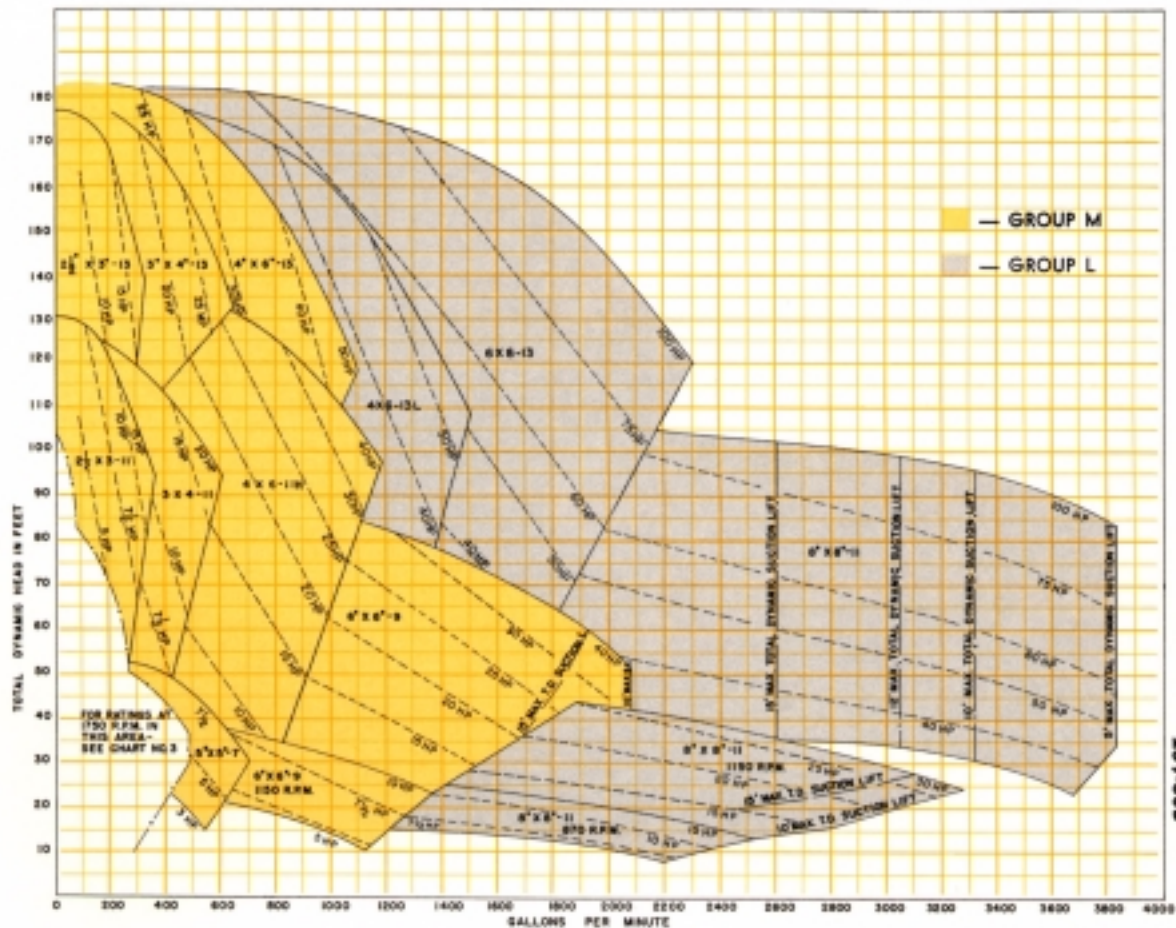

GROUP "M" & "L" • 1750 & 1150 RPM

Ratings shown are suitable for 15 ft. suction lift when handling clear, cold water at sea level, except where otherwise noted.

DIMENSIONS

All Dimensions are in inches.
Not to be used for construction purposes

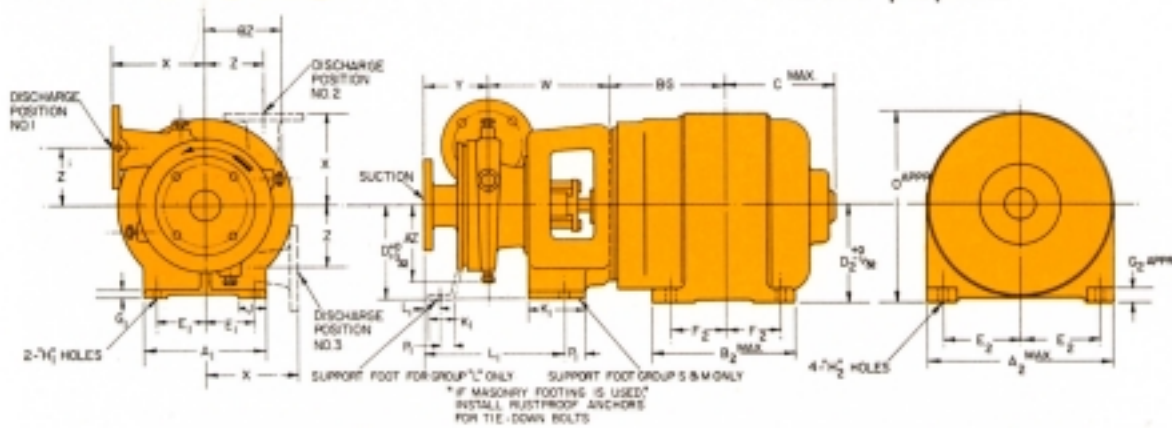

DIMENSIONS DETERMINED BY PUMP

GRP	DISCH SIZE	SUCT SIZE	CASG SIZE	A ₁	E ₁	G ₁	H ₁	J ₁	K ₁	L ₁	W	X	Y	Z	P ₁	A ₂	B ₂	WT.
S	1 1/4	1 1/2	5							7 1/2	4 3/4	3 1/4	3		3 3/8	4	85	
	1 1/2	2	5							7 3/8	4 3/4	3 1/2	3 1/8		4 1/8	4 3/8	70	
	3	3	5							8 1/8	6	4 1/2	3 3/4		4	4 1/2	85	
	2 1/2	2 1/2	6	5/16	2 1/2	3/16	3/16	1 3/4	3/2	7 7/8	5 1/2	4	3 1/4		4 5/8	4 3/4	80	
	1 1/4	1 1/2	7							7 7/8	5 1/4	3 1/4	3 3/4		4 5/8	5 1/8	75	
	2	2	7							7 7/8	5 3/8	3 3/4	3 3/4		4 1/2	4 3/4	80	
	4	4	7							8 1/8	7	5	5		5 3/8	5 3/8	95	
	1 1/4	1 1/2	8							7 3/8	6	3 1/2	4 1/4		5 3/8	5 3/8	80	
M	2	3	7							8 1/8	6 1/2	4 1/2	4		5 7/8	6 1/8	105	
	3	4	7							9 1/8	7	5	4 1/4		6 3/4	6 3/4	120	
	4	5	7							9 1/8	7 1/2	5 1/2	4 1/2		6 3/8	6 3/8	140	
	5	5	7							9 1/8	8	5 1/2	5		6 3/4	6 3/8	160	
	1 1/2	2	9							8 1/8	6 3/4	4	5 1/4		6 3/8	6 1/2	110	
	2	2 1/2	9	5/16	4	3/8	1 1/16	1 3/4	4	8 1/8	6 3/4	4	5		6 3/8	6 1/8	120	
	2 1/2	3	9							8 1/8	7 1/4	4 1/4	5 1/4		6 3/8	6 1/8	125	
	6	6	9							10 5/8	9 1/2	6 3/4	8		8 1/2	8 1/2	165	
	2 1/2	3	11							9 1/8	7 3/4	4 1/4	6 1/2		7 3/8	7 3/8	130	
	3	4	11							9 1/8	7 1/2	5 1/4	7 1/8		7 3/8	8 1/8	155	
	4	6	11H							10 1/8	8 1/2	6	7 1/4		8 3/4	8 3/8	180	
	2 1/2	3	13							9 1/8	8 1/4	8 1/2	4 3/4	7	8 1/8	8 3/8	150	
3	4	13							9 1/8	8 3/4	8 1/2	5 1/8	7 1/2	8 3/8	8 3/8	160		
4	6	13							10 1/8	8 3/8	9	5 1/2	7 1/2	8 1/2	9	190		
L	8	8	11	0	3 1/4	3 1/8	1 1/8	2 1/4	2	2 1/8	10 1/2	8 1/2	10	1 1/4	11 1/4	12 3/4	365	
	4	6	13L							1 1/8	9 1/2	9	5 1/2	7 1/2	1	8 1/2	9 3/4	305
	6	8	13							2	10	6 1/2	8 1/4	1 1/4	9 3/8	10 3/4	330	

FLANGE DIMENSION (25 LB STD)

I.D.	O.D.	B.C.	THICKNESS	NO OF HOLES	SIZE OF HOLES
1 1/4	4 7/8	3 1/2	1/2	4	7/8
1 1/2	5	3 3/4	5/8	4	7/8
2	6	4 3/4	5/8	4	3/4
2 1/2	7	5 1/2	1 1/8	4	3/4
3	7 1/2	6	3/4	4	3/4
4	9	7 1/2	1 1/8	8	3/4
5	10	8 1/2	1 1/8	8	7/8
6	11	9 1/2	1	8	7/8
8	13 1/2	11 3/4	1 1/8	8	7/8

* FLANGE THICKNESS ON 846-11 PUMP IS 1 1/8"

DIMENSIONS DETERMINED BY MOTOR

MOTOR FRAME	A ₂ MAX	B ₂ MAX	B ₃	C	D ₂	D ₁ (RAMP FOOT)	E ₂	F	G ₂ APPROX	H ₂	O MAX	W	APPROX WT. (LBS)	APPROX WT. (KGS)
145TC	7	6	4 1/8	5 1/4	3 1/2	4 1/2	-	2 3/4	2	1 1/8	1 1/2	7 1/4	35	40
145TC	7	6	5 3/8	6 1/4	3 1/2	4 1/2	-	2 3/4	2 1/8	1 1/8	7 1/4	45	50	
182TC	9	8 1/2	5 7/8	6 3/4	4 1/2	4 3/4	6 1/4	3 1/4	2 1/4	1 3/8	9 1/4	70	95	
184TC	9	7 1/2	6 3/8	7 1/4	4 1/2	4 3/4	6 1/4	3 1/4	2 1/4	1 3/8	9 1/4	85	110	
213TC	10 1/2	7 1/2	7 1/4	8 1/4	5 1/4	4 3/4	6 1/4	4 1/4	2 1/4	1 3/8	11 1/4	120	158	
215TC	10 1/2	9	8	9 1/8	5 1/4	4 3/4	6 1/4	4 1/4	3 1/2	1 3/8	11 1/4	140	190	
254TC	12 1/2	10 3/4	8 3/8	10 1/2	6 1/4	4 3/4	6 1/4	5	4 1/8	1 3/8	13 1/2	210	270	
258TC	12 1/2	12 1/2	10	11 3/8	6 1/4	4 3/4	6 1/4	5	5	1 3/8	13 1/2	230	305	
284TC	14	12 1/2	9 3/4	12 1/2	7	7	7	5 1/2	4 3/4	1 3/8	14 1/2	310	405	
286TC	14	14	10 1/2	13 1/4	7	7	7	5 1/2	5 1/2	1 3/8	14 1/2	340	465	
324TC	16	14	10 3/8	13 3/8	8	7	8 1/2	6 1/4	5 1/4	1 3/8	16 1/2	420	575	
326TC	16	15 1/2	11 1/2	14 3/8	8	7	8 1/2	6 1/4	6	1 3/8	16 1/2	470	640	
364TC	18	15 1/4	11 3/4	15 1/2	9	7	8 1/2	7	5 3/8	1 3/8	18 1/2	560	800	
366TC	18	16 1/4	12 1/4	16	9	7	8 1/2	7	6 1/8	1 3/8	18 1/2	630	900	
404TC	20	16 1/4	13	16 1/2	10	-	8 1/2	8	6 3/8	1 3/8	21	830	-	
405TC	20	17 1/4	13 1/4	17 1/4	10	-	8 1/2	8	6 3/8	1 3/8	21	925	1180	

* PUMP FOOT EXTENDS BELOW MOTOR FEET, ON SOME SIZES
PUMP CASING WILL EXTEND BELOW PUMP FOOT &/OR MOTOR FEET.
CHECK DIMENSIONS (A₂, B₂) CAREFULLY BEFORE MAKING FOUNDATION.



GOULDS PUMPS, INC.

Main Plant and Headquarters, Seneca Falls, N.Y. 13158