

 **GOULDS PUMPS**

Installation, Operation, and Maintenance Manual

XHD

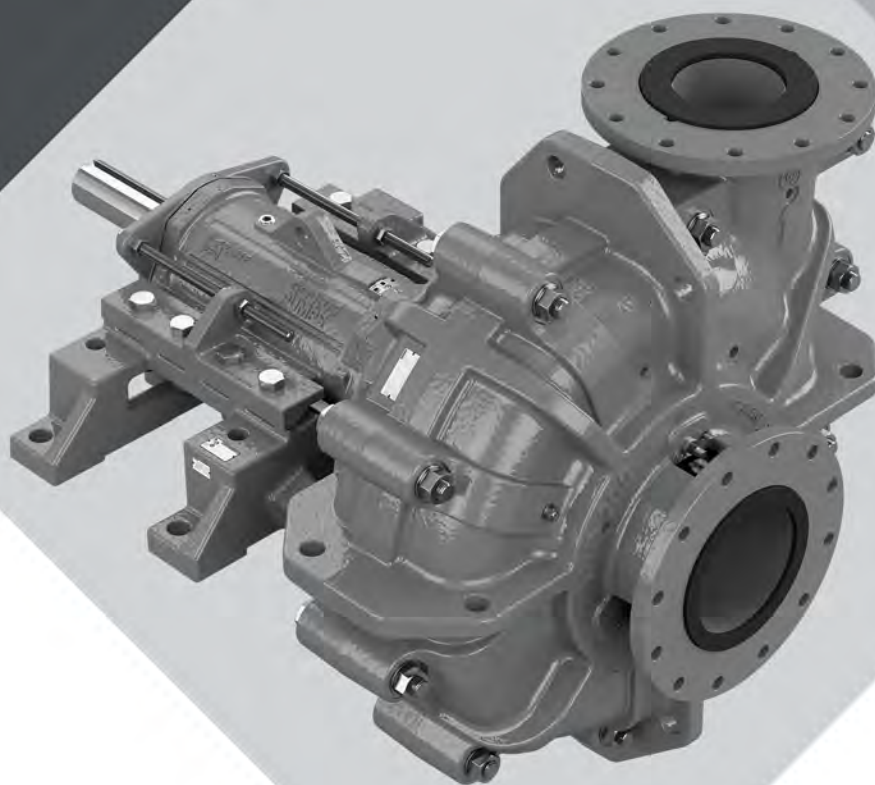

ITT

Table of Contents

1 Introduction and Safety	5
1.1 Introduction.....	5
1.1.1 Requesting other information	5
1.2 Safety	5
1.2.1 Safety terminology and symbols	6
1.2.2 Environmental safety.....	7
1.2.3 User safety	8
1.3 Product approval standards	10
1.4 Ex Considerations and Intended Use.....	11
1.5 Product warranty	15
2 Transportation and Storage.....	17
2.1 Inspect the delivery	17
2.1.1 Inspect the package	17
2.1.2 Inspect the unit.....	17
2.2 Transportation guidelines	17
2.2.1 Precautions	17
2.2.2 Pump handling	17
2.2.3 Lifting methods.....	17
2.3 Storage guidelines.....	19
2.3.1 Storage location	19
2.4 Pump storage requirements	19
2.5 Frostproofing	19
3 Product Description	20
3.1 General description i-ALERT® Equipment Health Monitor	20
3.2 Nameplate information	20
4 Installation.....	24
4.1 Pre-installation.....	24
4.1.1 Pump location guidelines	24
4.1.2 Foundation requirements	25
4.2 Baseplate-mounting procedures	26
4.2.1 Prepare the baseplate for mounting.....	26
4.2.2 Install the baseplate using shims or wedges.....	26
4.2.3 Install the baseplate using jackscrews	27
4.2.4 Direct-coupled baseplateBaseplate-leveling worksheet.....	31
4.3 Install pump, driver, and v-belt drive.....	32
4.3.1 Install and align the sheaves.....	32
4.3.2 Install and tension the belt	32
4.4 Install the pump, driver, and coupling.....	33
4.5 Pump-to-driver alignment	33
4.5.1 Alignment checks	34
4.5.2 Permitted indicator values for alignment checks	34
4.5.3 Alignment measurement guidelines	35
4.5.4 Attach the dial indicators for alignment	35
4.5.5 Pump-to-driver alignment instructions.....	35
4.6 Grout the baseplate.....	39

4.7 Piping checklists.....	40
4.7.1 General piping checklist.....	40
4.7.2 Suction-piping checklist.....	42
4.7.3 Discharge piping checklist.....	45
4.7.4 Bypass-piping considerations	46
4.7.5 Auxiliary-piping checklist.....	47
4.7.6 Final piping checklist.....	47
5 Commissioning, Startup, Operation, and Shutdown	48
5.1 Preparation for startup.....	48
5.2 Remove the V-belt drive guard.....	49
5.3 Remove the coupling guard	50
5.4 Check the rotation	51
5.5 Impeller-clearance check	52
5.5.1 Impeller axial clearances.....	52
5.6 Impeller-clearance setting	52
5.6.1 Set impeller to Suction Seal Ring Clearance Dial Indicator Method	54
5.6.2 Set impeller clearance dial indicator method - XHD.....	57
5.6.3 Suction seal ring clearance check - XHD only	58
5.7 Install the V-belt drive guard.....	59
5.8 V-Belt drive operation.....	59
5.8.1 V belt drive installation checks	59
5.8.2 V-belt drive monitoring and protection.....	59
5.9 Couple the pump and driver.....	60
5.9.1 Install the coupling guard	61
5.10 Bearing lubrication.....	66
5.10.1 Lubricate the bearings with oil.....	66
5.11 Shaft-sealing options	66
5.11.1 Mechanical seal options	67
5.11.2 Connection of sealing liquid for mechanical seals.....	67
5.11.3 Packed stuffing box option	67
5.11.4 Connection of sealing liquid for a packed stuffing box	68
5.11.5 Seal the shaft with a packed stuffing box	68
5.12 Install the shaft guard - if provided	71
5.13 Pump priming	71
5.13.1 Prime the pump with the suction supply above the pump.....	72
5.13.2 Prime the pump with the suction supply below the pump	72
5.13.3 Other methods of priming the pump.....	73
5.14 Start the pump.....	73
5.15 i-ALERT® Equipment Health Monitor.....	74
5.16 Pump operation precautions	74
5.17 Shut down the pump	76
5.18 Deactivate the i-ALERT® Equipment Health Monitor.....	76
5.19 Reset the i-ALERT® Health Monitor	76
5.20 Make the final alignment of the pump and driver	77
6 Maintenance.....	78
6.1 Maintenance schedule	78
6.1.1 Bearing maintenance	79
6.1.2 Lubricating oil requirements	79

6.1.3 Oil volumes	80
6.1.4 Acceptable oil for lubricating bearings	80
6.1.5 Lubricating-grease requirements	81
6.1.6 Shaft-seal maintenance	82
6.2 Disassembly	85
6.2.1 Disassembly precautions	85
6.2.2 Wet end disassembly instructions	86
6.2.3 Tools required	86
6.2.4 Disassembly for Metal-Lined	86
6.2.5 Typical disassembly - Metal-Lined	86
6.2.6 Complete wet end disconnection - XHD only	87
6.2.7 Wet end disassembly instructions	88
6.2.8 Disassembly for Rubber-Lined	97
6.2.9 Disassembly - Rubber-Lined	97
6.2.10 Remove the joint gaskets and flanges - Rubber-Lined	98
6.2.11 Remove the suction half casing - Rubber-Lined	98
6.2.12 Remove the remaining suction half components - Rubber-Lined	99
6.2.13 Remove suction side liner - XHD Single Piece Suction Liner - Rubber-Lined	99
6.2.14 Impeller removal - Rubber-Lined	100
6.2.15 Remove the shaft guard	101
6.2.16 Stuffing box removal	102
6.2.17 Remove the split stuffing box XHD	102
6.2.18 Remove the casing volute liner - Rubber-Lined	102
6.2.19 Remove the power end - quick disconnect option for XHD	104
6.2.20 Remove the expeller (optional feature)	104
6.2.21 Remove the seal cover and gland half casing assembly	105
6.2.22 Optional disassembly of gland half casing, gland liner, and seal cover - Rubber-Lined	106
6.2.23 Locate and lift the volute liner for optional discharge locations (field replacement) - Rubber-Lined	108
6.2.24 Remove the shaft sleeve	108
6.2.25 Remove the power end- XHD and XHD Value Option	109
6.2.26 Disassemble the power end - XHD, oil lubrication	111
6.2.27 Disassembly of other power end configurations	113
6.2.28 Guidelines for i-ALERT® Equipment Health Monitor disposal	114
6.3 Preassembly inspections	114
6.3.1 Replacement guidelines	115
6.3.2 Fastening	115
6.3.3 Power end inspection	116
6.4 Reassembly	116
6.4.1 Assemble the power end- XHD, oil lubrication	116
6.4.2 Assemble the power end to the pedestal	119
6.4.3 Assembly of other power end configurations	120
6.4.4 Wet end assembly instructions	121
6.4.5 Complete wet end connection - XHD	121
6.4.6 Wet end assembly instructions	122
6.4.7 Assembly references	134
6.4.8 Install the shaft guard	140
7 Troubleshooting	142
7.1 Operation troubleshooting	142

7.2 Alignment troubleshooting.....	143
7.3 Assembly troubleshooting	143
8 Parts List and Cross-Sectionals	145
8.1 Assembly drawings - (exploded views)	145
9 Certification.....	156
9.1	156
10 Other Relevant Documentation or Manuals.....	160
10.1 For additional documentation	160
11 Local ITT Contacts	161
11.1 Regional offices	161

1 Introduction and Safety

1.1 Introduction

Purpose of this manual

The purpose of this manual is to provide necessary information for:

- Installation
- Operation
- Maintenance



CAUTION:

Failure to observe the instructions contained in this manual could result in personal injury and/or property damage, and may void the warranty. Read this manual carefully before installing and using the product.

NOTICE:

Save this manual for future reference and keep it readily available.

1.1.1 Requesting other information

Special versions can be supplied with supplementary instruction leaflets. See the sales contract for any modifications or special version characteristics. For instructions, situations, or events that are not considered in this manual or in the sales documents, please contact the nearest ITT representative.

Always specify the exact product type and serial number when requesting technical information or spare parts.

Specifications such as weights, dimensions or centers of gravity of the pump, pump unit or subassemblies are described in the supplier's applicable documentation.

1.2 Safety



WARNING:

- The operator must be aware of the pumpage and take appropriate safety precautions to prevent physical injury.
- Risk of serious injury or death. If any pressure-containing device is over-pressurized, it can explode, rupture, or discharge its contents. It is critical to take all necessary measures to avoid over-pressurization.
- Risk of death, serious personal injury, and property damage. Installing, operating, or maintaining the unit using any method not prescribed in this manual is prohibited. Prohibited methods include any modification to the equipment or use of parts not provided by ITT. If there is any uncertainty regarding the appropriate use of the equipment, please contact an ITT representative before proceeding.
- Risk of serious personal injury. Applying heat to impellers, propellers, or their retaining devices can cause trapped liquid to rapidly expand and result in a violent explosion. This manual clearly identifies accepted methods for disassembling units. These methods must be adhered to. Never apply heat to aid in their removal unless explicitly stated in this manual.

- Risk of serious personal injury or property damage. Dry running may cause rotating parts within the pump to seize to non-moving parts. Do not run dry.
- Running a pump without safety devices exposes operators to risk of serious personal injury or death. Never operate a unit unless appropriate safety devices (guards, etc.) are properly installed. See specific information about safety devices in other sections of this manual.
- Risk of death, serious personal injury, and property damage. Heat and pressure buildup can cause explosion, rupture, and discharge of pumpage. Never operate the pump with suction and/or discharge valves closed.
- Precautions must be taken to prevent physical injury. The pump may handle hazardous and/or toxic fluids. Proper personal protective equipment should be worn. Pumpage must be handled and disposed of in conformance with applicable environmental regulations.
- If the pump or motor is damaged or leaking, electric shock, fire, explosion, liberation of toxic fumes, physical harm, or environmental damage may result. Do not operate the unit until the problem has been corrected or repaired.



CAUTION:

Risk of injury and/or property damage. Operating a pump in an inappropriate application can cause over pressurization, overheating, and/or unstable operation. Do not change the service application without the approval of an authorized ITT representative.

1.2.1 Safety terminology and symbols

About safety messages

It is extremely important that you read, understand, and follow the safety messages and regulations carefully before handling the product. They are published to help prevent these hazards:

- Personal accidents and health problems
- Damage to the product
- Product malfunction

Hazard levels

Hazard level	Indication
<p>DANGER:</p>	A hazardous situation which, if not avoided, will result in death or serious injury
<p>WARNING:</p>	A hazardous situation which, if not avoided, could result in death or serious injury
<p>CAUTION:</p>	A hazardous situation which, if not avoided, could result in minor or moderate injury
<p>NOTICE:</p>	<ul style="list-style-type: none"> • A potential situation which, if not avoided, could result in undesirable conditions • A practice not related to personal injury

Hazard categories

Hazard categories can either fall under hazard levels or let specific symbols replace the ordinary hazard level symbols.

Electrical hazards are indicated by the following specific symbol:



ELECTRICAL HAZARD:

These are examples of other categories that can occur. They fall under the ordinary hazard levels and may use complementing symbols:

- Crush hazard
- Cutting hazard
- Arc flash hazard

1.2.2 Environmental safety

The work area

Always keep the station clean to avoid and/or discover emissions.



WARNING:

Move equipment to a safe/non Ex environment for repairs/adjustments or use spark resistant tools and work methods.

Waste and emissions regulations

Observe these safety regulations regarding waste and emissions:

- Appropriately dispose of all waste.
- Handle and dispose of the processed liquid in compliance with applicable environmental regulations.
- Clean up all spills in accordance with safety and environmental procedures.
- Report all environmental emissions to the appropriate authorities.



WARNING:

If the product has been contaminated in any way, such as from toxic chemicals or nuclear radiation, do NOT send the product to ITT until it has been properly decontaminated and advise ITT of these conditions before returning.

Electrical installation

For electrical installation recycling requirements, consult your local electric utility.

1.2.2.1 Recycling guidelines

Always follow local laws and regulations regarding recycling.

1.2.3 User safety

General safety rules

These safety rules apply:

- Always keep the work area clean.
- Pay attention to the risks presented by gas and vapors in the work area.
- Avoid all electrical dangers. Pay attention to the risks of electric shock or arc flash hazards.
- Always bear in mind the risk of drowning, electrical accidents, and burn injuries.

Safety equipment

Use safety equipment according to the company regulations. Use this safety equipment within the work area:

- Hardhat
- Safety goggles, preferably with side shields
- Protective shoes
- Protective gloves
- Gas mask
- Hearing protection
- First-aid kit
- Safety devices

Electrical connections

Electrical connections must be made by certified electricians in compliance with all international, national, state, and local regulations. For more information about requirements, see sections dealing specifically with electrical connections.

Noise



WARNING:

Sound pressure levels may exceed 80 dbA in operating process plants. Clear visual warnings or other indicators should be available to those entering an area with unsafe noise levels. Personnel should wear appropriate hearing protection when working on or around any equipment, including pumps. Consider limiting personnel's exposure time to noise or, where possible, enclosing equipment to reduce noise. Local law may provide specific guidance regarding exposure of personnel to noise and when noise exposure reduction is required.

Temperature



WARNING:

Equipment and piping surfaces may exceed 130°F (54°C) in operating process plants. Clear visual warnings or other indicators should alert personnel to surfaces that may reach a potentially unsafe temperature. Do not touch hot surfaces. Allow pumps operating at a high temperature to cool sufficiently before performing maintenance. If touching a hot surface cannot be avoided, personnel should wear appropriate gloves, clothing, and other protective gear as necessary. Local law may provide specific guidance regarding exposure of personnel to unsafe temperatures.

1.2.3.1 Precautions before work

Observe these safety precautions before you work with the product or are in connection with the product:

- Provide a suitable barrier around the work area, for example, a guard rail.
- Make sure that all safety guards are in place and secure.
- Recognize the site emergency exits, eye wash stations, emergency showers and toilets.
- Allow all system and pump components to cool before you handle them.
- Make sure that you have a clear path of retreat.
- Make sure that the product cannot roll or fall over and injure people or damage property.
- Make sure that the lifting equipment is in good condition.
- Use a lifting harness, a safety line, and a breathing device as required.
- Make sure that the product is thoroughly clean.
- Make sure that there are no poisonous gases within the work area.
- Make sure that you have quick access to a first-aid kit.
- Disconnect and lock out power before servicing.
- Check the explosion risk before you weld or use electric hand tools.

1.2.3.2 Precautions during work

Observe these safety precautions when you work with the product or are in connection with the product:



CAUTION:

Failure to observe the instructions contained in this manual could result in personal injury and/or property damage, and may void the warranty. Read this manual carefully before installing and using the product.

- Never work alone.
- Always wear protective clothing and hand protection.
- Stay clear of suspended loads.
- Always lift the product by its lifting device.
- Beware of the risk of a sudden start if the product is used with an automatic level control.
- Beware of the starting jerk, which can be powerful.
- Rinse the components in water after you disassemble the pump.
- Do not exceed the maximum working pressure of the pump.
- Do not open any vent or drain valve or remove any plugs while the system is pressurized. Make sure that the pump is isolated from the system and that pressure is relieved before you disassemble the pump, remove plugs, or disconnect piping.
- Never operate a pump without a properly installed v-belt or coupling guard.
- Always bear in mind the risk of drowning, electrical accidents, and burn injuries.
- Never heat the condition monitor to temperatures in excess of 300°F (149°C).
- Never expose the condition monitor to open flames.
- Do not use the condition monitor in atmospheres containing acetic acid.
- Always wear protective gloves. The pump and condition monitor can be hot.

1.2.3.3 Hazardous liquids

The product is designed for use in liquids that can be hazardous to your health. Observe these rules when you work with the product:

- Make sure that all personnel who work with biologically hazardous liquids are vaccinated against diseases to which they may be exposed.
- Observe strict personal cleanliness.
- A small amount of liquid will be present in certain areas like the seal chamber.

1.2.3.4 Wash the skin and eyes

1. Follow these procedures for chemicals or hazardous fluids that have come into contact with your eyes or your skin:

Condition	Action
Chemicals or hazardous fluids in eyes	<ol style="list-style-type: none"> 1. Hold your eyelids apart forcibly with your fingers. 2. Rinse the eyes with eyewash or running water for at least 15 minutes. 3. Seek medical attention.
Chemicals or hazardous fluids on skin	<ol style="list-style-type: none"> 1. Remove contaminated clothing. 2. Wash the skin with soap and water for at least 1 minute. 3. Seek medical attention, if necessary.

1.3 Product approval standards

Regular standards



WARNING:

Use of equipment unsuitable for the environment can pose risks of ignition and/or explosion. Ensure the pump driver and all other auxiliary components meet the required area classification at the site. If they are not compatible, do not operate the equipment and contact an ITT representative before proceeding.

All standard products are approved according to CSA standards in Canada and UL standards in USA. The drive unit degree of protection follows IP68 See the nameplate for maximum submersion, according to standard IEC 60529.

All electrical ratings and performance of the motors comply with IEC 600341.

Explosion-proofing standards

All explosion-proof products for use in explosive atmospheres are designed in compliance with one or more of the following approvals:

- FM According to NEC
 - Class 1 Div 1 Groups “C”, and “D”
 - Class 2 Div 1 Groups “E”, “F”, and “G”
 - Class 3 Div 1 Hazardous Locations

CSA certification

Intrinsically safe for:

- Class I, Div. 1, Groups A, B, C, D

- Class II, Div. 1, Groups E, F, G
- Class III
- Certified to Canadian and US requirements

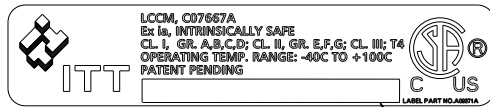

SERIAL NO& YEAR OF
MANUFACTURE HERE.

1.4 Ex Considerations and Intended Use

Special care must be taken in potentially explosive environments to ensure that the equipment is properly operated and maintained. Compliance with the essential safety and health requirements has been assured by compliance with the following standards, method of protection Constructional Safety (C): ISO 80079-36 ISO 80079-37



Follow these special handling instructions if you have an Ex-approved unit.

Personnel requirements

These are the personnel requirements for Ex-approved products in potentially explosive atmospheres:

- All work on the product must be carried out by certified electricians and ITT-authorized mechanics. Special rules apply to installations in explosive atmospheres.
- All users must know about the risks of electric current and the chemical and physical characteristics of the gas, the vapor, or both present in hazardous areas.
- Any maintenance for Ex-approved products must conform to international and national standards (for example, EN 60079-17).

ITT disclaims all responsibility for work done by untrained and unauthorized personnel.

Product and product handling requirements

These are the product and product handling requirements for Ex-approved products in potentially explosive atmospheres:

- Only use the product in accordance with the approved motor data.
- The Ex-approved product must never run dry during normal operation. Dry running during service and inspection is only permitted outside the classified area.
- Before you start work on the product, make sure that the product and the control panel are isolated from the power supply and the control circuit, so they cannot be energized.
- Do not open the product while it is energized or in an explosive gas atmosphere.
- Make sure that thermal contacts are connected to a protection circuit according to the approval classification of the product, and that they are in use.

- Intrinsically safe circuits are normally required for the automatic level-control system by the level regulator if mounted in zone 0.
- Do not modify the equipment without approval from an authorized ITT representative.
- Only use parts that are provided by an authorized ITT representative.

Description of Ex-Directives

The Ex-directives are a specification enforced in Europe and the United Kingdom for electrical and non-electrical equipment installed in those locations. Ex-directives deal with the control of potentially explosive atmospheres and the standards of equipment and protective systems used within these atmospheres. The relevance of the Ex-requirements is not limited to Europe or the UK. You can apply these guidelines to equipment installed in any potentially explosive atmosphere.

Guidelines for compliance

Compliance is fulfilled only when you operate the unit within its intended use. Do not change the conditions of the service without the approval of an ITT representative. When you install or maintain explosion proof products, always comply with the directive and applicable standards (for example, IEC/EN 60079-14).

1. Monitoring the pump frame liquid end temperature.
2. Maintaining proper bearing lubrication.
3. Ensuring that the pump is operated in the intended hydraulic range.

The Ex conformance is only applicable when the pump unit is operated within its intended use. Operating, installing or maintaining the pump unit in any way that is not covered in the Instruction, Operation, and Maintenance manual (IOM) can cause serious personal injury or damage to the equipment. This includes any modification to the equipment or use of parts not provided by ITT Goulds Pumps. If there is any question regarding the intended use of the equipment, please contact an ITT Goulds representative before proceeding.

Current IOMs are available at <https://www.gouldspumps.com/en-US/Tools-and-Resources/Literature/IOMs/> or from your local ITT Goulds Pumps Sales representative.

All pumping unit (pump, seal, coupling, motor and pump accessories) certified for use in an Ex classified environment, are identified by an Ex tag secured to the pump or the baseplate on which it is mounted. A typical tag would look like this:

If applicable, your pump may have either a CE Ex (ATEX) tag or UKCA Ex tag affixed to the pump. See the Safety section for a description of the symbols and codes. Typical nameplate only shown below, the actual area classification may be different.

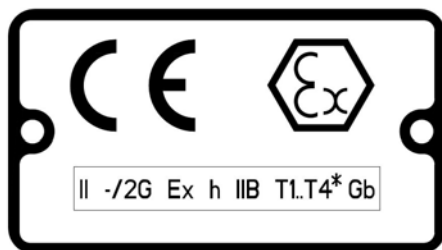

Figure 1: Typical Ex nameplate



Figure 2: Typical UKCA Ex nameplate

Table 1: Temperature class definitions

Code	Maximum permissible surface temperature in °C °F	Maximum permissible liquid temperature in °C °F
T1	440 824	372 700
T2	290 554	267 513
T3	195 383	172 342
T4	130 266	107 225
T5	Option not available	Option not available
T6	Option not available	Option not available

* Maximum liquid temperature may be limited by the pump model and order specific options. [Table 1: Temperature class definitions on page 13](#) is for the purpose of determining 'T' code for Ex applications with liquid temperatures exceeding 107°C | 225°F.

The code classification marked on the equipment must be in accordance with the specified area where the equipment will be installed. If it is not, do not operate the equipment and contact your ITT Goulds Pumps sales representative before proceeding.

Recommended bearing replacement interval (based on L10 life) = 17,520 hours of operation.

Equipment for monitoring

For additional safety, use condition-monitoring devices. Condition-monitoring devices include but are not limited to these devices:

- Pressure gauges
- Flow meters
- Level indicators
- Motor load readings
- Temperature detectors
- Bearing monitors
- Leak detectors
- PumpSmart control system



WARNING:

- When pumping unit is installed in a potentially explosive atmosphere, the instructions after the Ex symbol must be followed. Personal injury and/or equipment damage may occur if these instructions are not followed. If there is any question regarding these requirements or if the equipment is to be modified, please contact a Goulds representative before proceeding.
- If equipment is to be installed in a potentially explosive atmosphere and these procedures are not followed, personal injury or equipment damage from an explosion may result.
- Particular care must be taken when the electrical power source to the equipment is energized.
- Improper impeller adjustment could cause contact between the rotating and stationary parts, resulting in a spark and heat generation.
- Lock out driver power to prevent electric shock, accidental start-up and physical injury.
- NEVER start pump without proper prime (all models), or proper liquid level in self-priming pumps (Model 3796 and SP3298).
- Equipment that will operate in a potentially explosive environment must be installed in accordance with the following instructions.

- All equipment being installed must be properly grounded to prevent unexpected static electric discharge. This includes ensuring that the PFA lined pumps (Model 3198), ETFE lined pumps (Model 3298, SP3298, V3298), and the non-metallic liquid end pumps (Model NM3196) are pumping fluids that are conductive. If not, a static electric discharge may occur when the pump is drained and disassembled for maintenance purposes.
- All equipment being installed must be properly grounded to prevent unexpected static electric discharge.
- When pumping fluids with conductivity less than 1000 ps/m follow IEC TS 60079 32-1 guidelines.
- Alignment procedures must be followed to prevent unintended contact of rotating parts. Follow coupling manufacturer's installation and operation procedures.
- When installing in a potentially explosive environment, ensure that the motor and accessories are properly certified.
- The impeller clearance setting procedure must be followed. Improperly setting the clearance or not following any of the proper procedures can result in sparks, unexpected heat generation and equipment damage.
- The impeller and wear ring clearance setting procedures must be followed. Improperly setting the clearance or not following any of the proper procedures can result in sparks, unexpected heat generation and equipment damage.
- Service temperature in an Ex classified environment is limited to the area classification specified on the Ex tag affixed to the pump (reference Table 1 in the Safety section for Ex classifications).
- The coupling used in an Ex classified environment must be properly certified.
- The coupling guard used in an Ex classified environment must be constructed from a spark-resistant material.
- Bearings must be lubricated properly in order to prevent excess heat generation, sparks and premature failure.
- The mechanical seal used in an Ex classified environment must be properly certified.
- The mechanical seal must have an appropriate seal flush system. Failure to do so will result in excess heat generation and seal failure.
- Packed stuffing boxes are not allowed in an Ex classified environment.
- Dynamic seals are not allowed in an Ex classified environment.
- Pumps that are not self-priming must be fully primed at all times during operation. The only model lines that are self-priming is the 3796 and SP3298.
- Pumps must be fully primed at all times during operation.
- The preventive maintenance section must be adhered to in order to keep the applicable Ex classification of the equipment. Failure to follow these procedures will void the Ex classification for the equipment. Bearing replacement intervals are given in the specific pump model IOM.
- Inspection intervals should be shortened appropriately if the pumpage is abrasive and/or corrosive, or if the environment is classified as potentially explosive.
- Throughout this section on bearing lubrication, different pumpage temperatures are listed. If the equipment is Ex certified and the listed temperature exceeds the applicable value shown in Table 1 under SAFETY, then that temperature is not valid. Should this situation occur, please consult with your ITT/Goolds representative.
- Cooling systems, such as those for bearing lubrication, mechanical seal systems, etc., where provided, must be operating properly to prevent excess heat generation, sparks and premature failure.
- Rotate shaft by hand to ensure it rotates smoothly and there is no rubbing which could lead to excess heat generation, sparks and premature failure.

- Flange loads from the piping system, including those from thermal expansion of the piping, must not exceed the limits of the pump. Casing deformation can result in contact with rotating parts which can result in excess heat generation, sparks and premature failure.
 - Ensure that pump and systems are free of foreign objects before operating and that objects cannot enter the pump during operation. Foreign objects in the pumpage or piping system can cause blockage of flow which can result in excess heat generation, sparks and premature failure.
 - Do not insulate or allow the bearing housings to accumulate a dust layer as this can result in excess heat generation, sparks and premature failure.
 - Check for magnetism on the pump shaft and demagnetize the shaft if there is any detectable magnetism. Magnetism will attract ferritic objects to the impeller, seals and bearings which can result in excess heat generation, sparks and premature failure.
 - Leakage of process liquid may result in creation of an explosive atmosphere. Ensure the materials of the pump casing, impeller, shaft, sleeves, gaskets and seals are compatible with the process liquid.
 - Leakage of process liquid may result in creation of an explosive atmosphere. Follow all pump and seal assembly procedures.
 - A buildup of gases within the pump, sealing system and or process piping system may result in an explosive environment within the pump or process piping system. Ensure process piping system, pump and sealing system are properly vented prior to operation.
 - Sealing systems that are not self purging or self venting, such as plan 23, require manual venting prior to operation. Failure to do so will result in excess heat generation and seal failure.
 - Do not apply additional paint or coatings to the pump when in an Ex environment. Static electric discharge can be initiated when contacting or rubbing surfaces with excessive coating thickness.
 - Potential electrostatic charging hazard. Do not rub, clean, or blast equipment with dry cloth or dry media.
 - Stray electrical currents may ignite explosive atmospheres. Ensure drives are certified for variable frequency drive operation by the manufacturer.
 - User shall observe necessity of using a safety device, such as a flame arrestor, to prevent flame entering or leaving the pump sump, tank, or barrel when applicable.
 - For variable speed motor applications, the electric motor must be specified with shaft grounding and used with a conductive type coupling suitable for the area classification.
 - In plants or pumps with cathodic corrosion protection, a small current constantly flows through the construction. This is not permissible on the complete pump or partially-assembled machinery without further precautions being taken. ITT should be consulted in this context.
-

1.5 Product warranty

Coverage

ITT undertakes to remedy faults in products from ITT under these conditions:

- The faults are due to defects in design, materials, or workmanship.
- The faults are reported to an ITT representative within the warranty period.
- The product is used only under the conditions described in this manual.
- The monitoring equipment incorporated in the product is correctly connected and in use.
- All service and repair work is done by ITT-authorized personnel.

- Genuine ITT parts are used.
- Only Ex-approved spare parts and accessories authorized by ITT are used in Ex-approved products.

Limitations

The warranty does not cover faults caused by these situations:

- Deficient maintenance
- Improper installation
- Modifications or changes to the product and installation made without consulting ITT
- Incorrectly executed repair work
- Normal wear and tear

ITT assumes no liability for these situations:

- Bodily injuries
- Material damages
- Economic losses

Warranty claim

ITT products are high-quality products with expected reliable operation and long life. However, should the need arise for a warranty claim, then contact your ITT representative.

2 Transportation and Storage

2.1 Inspect the delivery

2.1.1 Inspect the package

1. Inspect the package for damaged or missing items upon delivery.
2. Note any damaged or missing items on the receipt and freight bill.
3. File a claim with the shipping company if anything is out of order.
If the product has been picked up at a distributor, make a claim directly to the distributor.

2.1.2 Inspect the unit

1. Remove packing materials from the product.
Dispose of all packing materials in accordance with local regulations.
2. Inspect the product to determine if any parts have been damaged or are missing.
3. If applicable, unfasten the product by removing any screws, bolts, or straps.
For your personal safety, be careful when you handle nails and straps.
4. Contact your sales representative if anything is out of order.

2.2 Transportation guidelines

2.2.1 Precautions



WARNING:

- Stay clear of suspended loads.
 - Observe accident prevention regulations in force.
-

2.2.2 Pump handling



WARNING:

Dropping, rolling or tipping units, or applying other shock loads, can cause property damage and/or personal injury. Ensure that the unit is properly supported and secure during lifting and handling.



CAUTION:

Risk of injury or equipment damage from use of inadequate lifting devices. Ensure lifting devices (such as chains, straps, forklifts, cranes, etc.) are rated to sufficient capacity.

2.2.3 Lifting methods



WARNING:

- Risk of serious personal injury or equipment damage. Proper lifting practices are critical to safe transport of heavy equipment. Ensure that practices used are in compliance with all applicable regulations and standards.

- Safe lifting points are specifically identified in this manual. It is critical to lift the equipment only at these points. Integral lifting eyes or eye bolts on pump and motor components are intended for use in lifting the individual components only.
- Lifting and handling heavy equipment poses a crush hazard. Use caution during lifting and handling and wear appropriate Personal Protective Equipment (PPE, such as steel-toed shoes, gloves, etc.) at all times. Seek assistance if necessary.

Table 2: Methods

Pump type	Lifting method
A bare pump without lifting handles	Use a suitable sling attached properly to solid points like the casing, the flanges, or the frames.
A bare pump with lifting lugs	Use a suitable sling attached to the lifting lugs in the casing and bearing cartridge.
A base-mounted pump	Use slings under the pump casing and the drive unit, under the base rails, or through lifting lugs, when provided.

Examples

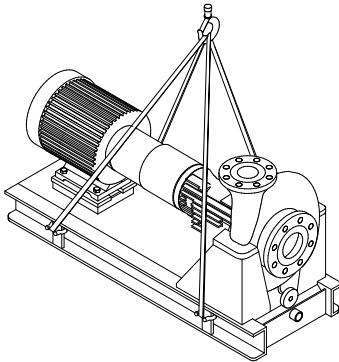

Figure 3: Example of a proper lifting method

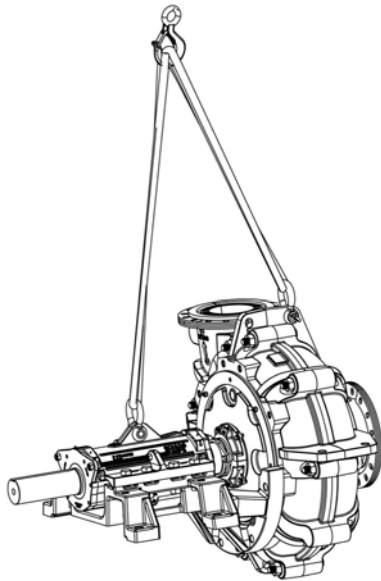

Figure 4: Example of bare pump proper lifting method

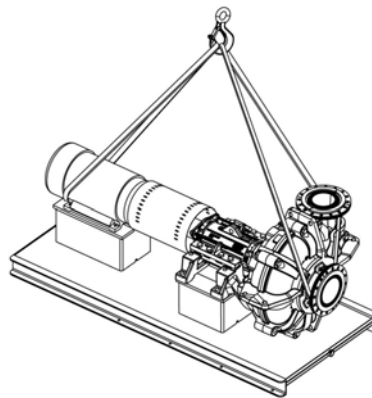

Figure 5: Example of base mounted pump proper lifting method

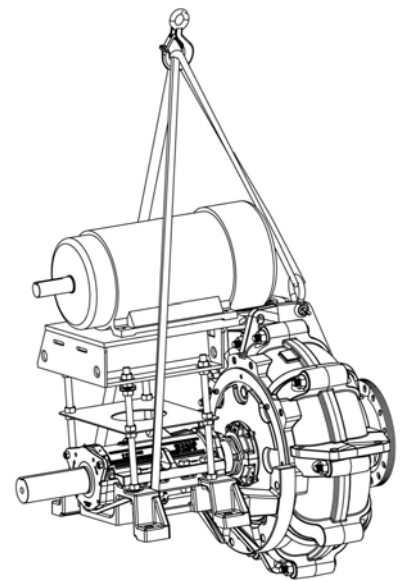

Figure 6: Example of overhead mounted pump proper lifting method

2.3 Storage guidelines

2.3.1 Storage location

The product must be stored in a covered and dry location free from heat, dirt, and vibrations.

NOTICE:

- Protect the product against humidity, heat sources, and mechanical damage.
 - Do not place heavy weights on the packed product.
-

2.4 Pump storage requirements

Storage requirements depend on the amount of time that you store the unit. The normal packaging is designed only to protect the unit during shipping.

Length of time in storage	Storage requirements
Upon receipt/short-term (less than six months)	<ul style="list-style-type: none"> • Store in a covered and dry location. • Store the unit free from dirt and vibrations.
Long-term (more than six months)	<ul style="list-style-type: none"> • Store in a covered and dry location. • Store the unit free from heat, dirt, and vibrations. • Rotate the shaft by hand several times at least every three months.

Treat bearing and machined surfaces so that they are well preserved. Refer to drive unit and coupling manufacturers for their long-term storage procedures.

You can purchase long-term storage treatment with the initial unit order or you can purchase it and apply it after the units are already in the field. Contact your local ITT sales representative.

2.5 Frostproofing

This table shows to what degree the pump is frostproof:

When the pump is...	Then...
Operating	The pump is frostproof.
Immersed in a liquid	The pump is frostproof.
Lifted out of a liquid into a temperature below freezing	The impeller might freeze.
Sitting idle	The pump might freeze.

3 Product Description

3.1 General description i-ALERT® Equipment Health Monitor

Description

The i-ALERT® Equipment Health Monitor is a compact, battery-operated monitoring device that continuously measures the vibration and temperature of the pump power end. The i-ALERT® sensor uses blinking LED and wireless notification to alert the pump operator when the pump exceeds vibration and temperature limits. This allows the pump operator to make changes to the process or the pump before a catastrophic failure occurs. The i-ALERT® monitor allows customers to identify potential problems before they become costly failures. It tracks vibration, temperature, change in electromagnetic field and run-time hours and wirelessly syncs the data with the i-ALERT Gateway or with a smart phone or tablet using i-ALERT® mobile app.

More information available on <https://www.i-alert.com/products/>

Current IOMs are available at <http://www.gouldspumps.com/en-us/tools-and-resources/literature/> - and - [resources/literature/](https://www.i-alert.com/) IOMs, <https://www.i-alert.com/> or your local ITT Goulds Pumps Sales Rep.

Alarm mode

The condition monitor enters alarm mode when either vibration or temperature limits are exceeded over two consecutive readings within a user defined period. Alarm mode is indicated with red flashing LED.

Table 3: Temperature and vibration limits

Variable	Limit
Temperature	100°C 195°F Surface Temperature
Vibration	100% increase over the baseline level

Battery life

The i-ALERT® Condition Monitor battery is replaceable.

The battery life is not covered as part of the standard pump warranty.

This table shows the average condition monitor battery life under normal and alarm-mode operating conditions.

Condition monitor operational state	Battery life
Normal operating and environmental conditions	Three to five years
Alarm mode	One year

3.2 Nameplate information

Important information for ordering

Every pump has nameplates that provide information about the pump. The nameplates are located on the casing and the bearing frame.

When you order spare parts, identify this pump information:

- Model
- Size
- Serial number

- Item numbers of the required parts

Item numbers can be found in the spare parts list.

Refer to the nameplate on the pump casing for most of the information. See Parts List for item numbers.

Nameplate on the pump casing using English units

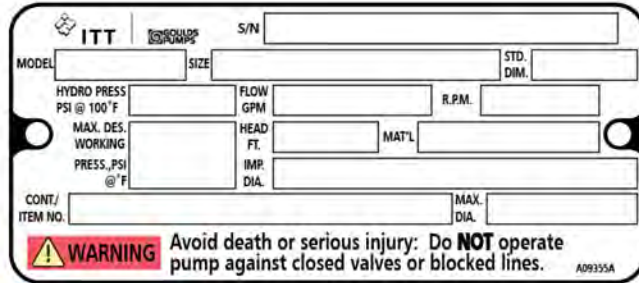

Figure 7: Nameplate on the pump casing using English units

Table 4: Explanation of nameplate on the pump casing

Nameplate field	Explanation
IMPLR. DIA.	Impeller diameter, in inches
MAX. DIA.	Maximum impeller diameter, in inches
GPM	Rated pump flow, in gallons per minute
FT HD	Rated pump head, in feet
RPM	Rated pump speed, revolutions per minute
MOD.	Pump model
SIZE	Size of the pump
STD. NO.	Does not apply
MAT L. CONST.	Material of which the pump is constructed
SER. NO.	Serial number of the pump
MAX DSGN PSI @ 100°F	Maximum pressure at 100° F according to the pump design

Nameplate on the pump casing using metric units

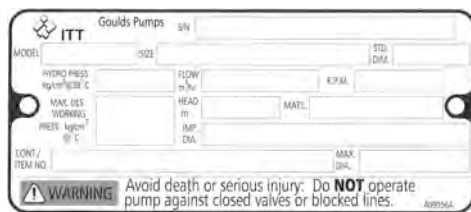

Figure 8: Metric units - nameplate on pump casing

Table 5: Explanation of the nameplate on the pump casing

Nameplate field	Explanation
IMPLR. DIA.	Impeller diameter
MAX. DIA.	Maximum impeller diameter
M ³ /HR	Rated pump flow, in cubic meters per hour
M HD	Rated pump head, in meters

3.2 Nameplate information

Nameplate field	Explanation
RPM	Rated pump speed, in revolutions per minute
MOD.	Pump model
SIZE	Size of the pump
STD. NO.	Does not apply
MAT L. CONST	Material of which the pump is constructed
SER. NO.	Serial number of the pump
MAX. DSGN KG/CM ² @20 °C	Kilograms per square centimeter at 20°C

Nameplate on the bearing frame



Figure 9: Nameplate on the bearing frame

Table 6: Explanation of the nameplate on the bearing frame

Nameplate field	Explanation
BRG. O. B.	Outboard bearing designation
BRG. I. B.	Inboard bearing designation
S/N	Serial number of the pump
LUBE	Lubricant, oil or grease

Ex nameplate

All pumping unit (pump, seal, coupling, motor and pump accessories) certified for use in an Ex classified environment, are identified by an Ex tag secured to the pump or baseplate on which it is mounted. A typical tag would look like this:

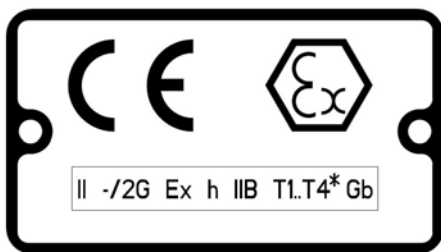

Figure 10: Typical Ex nameplate



Figure 11: Typical UKCA Ex nameplate

Table 7: Temperature class definitions

Code	Maximum permissible surface temperature in °C °F	Maximum permissible liquid temperature in °C °F
T1	440 824	372 700
T2	290 554	267 513
T3	195 383	172 342
T4	130 266	107 225
T5	Option not available	Option not available

Code	Maximum permissible surface temperature in °C °F	Maximum permissible liquid temperature in °C °F
T6	Option not available	Option not available

Recommended bearing replacement interval (based on L10 life) = 17,520 hours of operation.

The code classification marked on the equipment should be in accordance with the specified area where the equipment will be installed. If it is not, please contact your ITT/Goulds representative before proceeding.



WARNING:

Use of equipment unsuitable for the environment can pose risks of ignition and/or explosion. Ensure the pump driver and all other auxiliary components meet the required area classification at the site. If they are not compatible, do not operate the equipment and contact an ITT representative before proceeding.



WARNING:

- When pumping fluids with conductivity less than 1000 ps/m follow IEC TS 60079 32-1 guidelines.
 - The preventive maintenance section must be adhered to in order to keep the applicable Ex classification of the equipment. Failure to follow these procedures will void the Ex classification for the equipment. Bearing replacement intervals are given in the specific pump model IOM.
 - Do not insulate or allow the bearing housings to accumulate a dust layer as this can result in excess heat generation, sparks and premature failure.
 - Do not apply additional paint or coatings to the pump when in an Ex environment. Static electric discharge can be initiated when contacting or rubbing surfaces with excessive coating thickness.
 - Potential electrostatic charging hazard. Do not rub, clean, or blast equipment with dry cloth or dry media.
 - Stray electrical currents may ignite explosive atmospheres. Ensure drives are certified for variable frequency drive operation by the manufacturer.
 - User shall observe necessity of using a safety device, such as a flame arrestor, to prevent flame entering or leaving the pump sump, tank, or barrel when applicable.
-

4 Installation

4.1 Pre-installation

WARNING:

Equipment that will operate in a potentially explosive environment must be installed in accordance with the following instructions.

Precautions

WARNING:

- When installing in a potentially explosive environment, ensure that the motor is properly certified.
- All equipment being installed must be properly grounded to prevent unexpected discharge. Discharge can cause equipment damage, electric shock, and result in serious injury. Test the ground lead to verify it is connected correctly.

NOTICE:

- Electrical connections must be made by certified electricians in compliance with all international, national, state and local regulations.
- Supervision by an authorized ITT representative is recommended to ensure proper installation. Improper installation may result in equipment damage or decreased performance.

4.1.1 Pump location guidelines

Guideline	Explanation/comment
Keep the pump as close to the liquid source as practically possible.	This minimizes the friction loss and keeps the suction piping as short as possible.
Make sure that the space around the pump is sufficient.	This facilitates ventilation, inspection, maintenance, and service.
If you require lifting equipment such as a hoist or tackle, make sure that there is enough space above the pump.	This makes it easier to properly use the lifting equipment and safely remove and relocate the components to a safe location.
Protect the unit from weather and water damage due to rain, flooding, and freezing temperatures.	This is applicable if nothing else is specified.
Do not install and operate the equipment in closed systems unless the system is constructed with properly-sized safety devices and control devices.	Acceptable devices: <ul style="list-style-type: none"> • Pressure relief valves • Compression tanks • Pressure controls • Temperature controls • Flow controls <p>If the system does not include these devices, consult the engineer or architect in charge before you operate the pump.</p>
Take into consideration the occurrence of unwanted noise and vibration.	The best pump location for noise and vibration absorption is on a concrete floor with subsoil underneath.

Guideline	Explanation/comment
If the pump location is overhead, undertake special precautions to reduce possible noise transmission.	Consider a consultation with a noise specialist.

4.1.2 Foundation requirements

Requirements



- All equipment being installed must be properly grounded to prevent unexpected static electric discharge. If not, a static electric discharge may occur when the pump is drained and disassembled for maintenance purposes.
- The location and size of the foundation bolt holes must match those shown on the assembly drawing provided with the pump data package.
- The foundation must weigh between two and three times the weight of the complete pump, baseplate, and drive assembly.
- Provide a flat, substantial concrete foundation in order to prevent strain and distortion when you tighten the foundation bolts.

Sleeve-type bolts

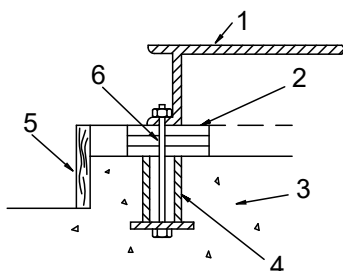

Item	Description
1.	Baseplate
2.	Shims
3.	Foundation
4.	Sleeve
5.	Dam
6.	Bolt

Figure 12: Sleeve type bolts

J-type bolts

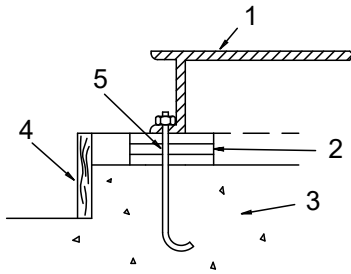

Item	Description
1.	Baseplate
2.	Shims or wedges
3.	Foundation
4.	Dam
5.	Bolt

Figure 13: J-type bolts

NOTICE:

Slurry Pumps are typically driven with motors mounted overhead, coupled with V-belts and sheaves. This configuration does not require the pump to be mounted and grouted into place. The pump pedestal can be bolted onto a concrete foundation using J-type bolts or Sleeve-type bolts, thru the pedestal or mounting feet.

4.2 Baseplate-mounting procedures

4.2.1 Prepare the baseplate for mounting

1. Remove all the attached equipment from the baseplate.
2. Clean the underside of the baseplate completely.
3. If applicable, coat the underside of the baseplate with an epoxy primer.
Use an epoxy primer only if using an epoxy-based grout.
4. Remove the rust-proofing coat from the machined mounting pads using an appropriate solvent.
5. Remove water and debris from the foundation-bolt holes.

4.2.2 Install the baseplate using shims or wedges

Required tools:

- Two sets of shims or wedges for each foundation bolt
- Two machinist's levels
- Baseplate-leveling worksheet

This procedure is applicable to cast iron and fabricated steel baseplates.

1. If you use sleeve-type bolts, fill the bolt sleeves with packing material or rags to prevent grout from entering the bolt holes.
2. Put the sets of wedges or shims on each side of each foundation bolt.
The sets of wedges should have a height of between 19 mm | 0.75 in. and 38 mm | 1.50 in.

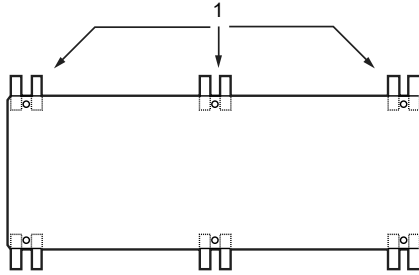

1. Shims or wedges

Figure 14: Top view

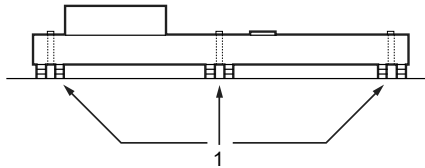

1. Shims or wedges

Figure 15: Side view

3. Lower the baseplate carefully onto the foundation bolts.
4. Put the machinist's levels across the mounting pads of the driver and the mounting pads of the pump.

NOTICE:

Remove all dirt from the mounting pads in order to ensure that the correct leveling is achieved. Failure to do so can result in equipment damage or decreased performance.

5. Level the baseplate both lengthwise and across by adding or removing shims or moving the wedges.

These are the leveling tolerances:

- A maximum difference of 3.2 mm | 0.125 in. lengthwise
- A maximum difference of 1.5 mm | 0.059 in. across

You can use the baseplate-leveling worksheet when you take the readings.

6. Hand-tighten the nuts for the foundation.

4.2.3 Install the baseplate using jackscrews

Tools required:

- Anti-seize compound
- Jackscrews
- Bar stock
- Two machinist's levels
- Baseplate-leveling worksheet

This procedure is applicable to the feature-fabricated steel baseplate and the advantage base baseplate.

1. Apply an anti-seize compound on the jackscrews.
The compound makes it easier to remove the screws after you grout.
2. Lower the baseplate carefully onto the foundation bolts and perform these steps:

- a) Cut the plates from the bar stock and chamfer the edges of the plates in order to reduce stress concentrations.
- b) Put the plates between the jackscrews and the foundation surface.
- c) Use the four jackscrews in the corners in order to raise the baseplate above the foundation. Make sure that the distance between the baseplate and the foundation surface is between 19 mm | 0.75 in. and 38 mm | 1.50 in.
- d) Make sure that the center jackscrews do not touch the foundation surface yet.

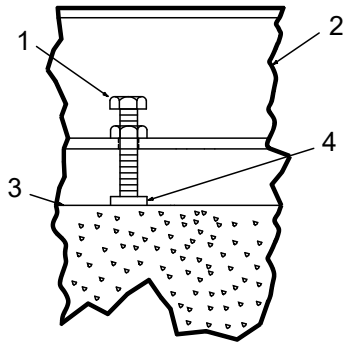

Item	Description
1.	Jackscrew
2.	Baseplate
3.	Foundation
4.	Plate

Figure 16: Jackscrews

3. Level the driver mounting pads:

NOTICE:

Remove all dirt from the mounting pads in order to ensure that the correct leveling is achieved. Failure to do so can result in equipment damage or decreased performance.

- a) Put one machinist's level lengthwise on one of the two pads.
- b) Put the other machinist's level across the ends of the two pads.
- c) Level the pads by adjusting the four jackscrews in the corners. Make sure that the machinist's level readings are as close to zero as possible, both lengthwise and across.

Use the baseplate-leveling worksheet when you take the readings.

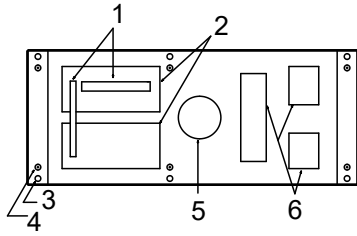

Item	Description
1.	Machinist's levels
2.	Driver's mounting pads
3.	Foundation bolts
4.	Jackscrews
5.	Grout hole
6.	Pump's mounting pads

Figure 17: Level driver mounting pads

4. Turn the center jackscrews down so that they rest on their plates on the foundation surface.
5. Level the pump mounting pads:

NOTICE:

Remove all dirt from the mounting pads in order to ensure that the correct leveling is achieved. Failure to do so can result in equipment damage or decreased performance.

- a) Put one machinist's level lengthwise on one of the two pads.
 - b) Put the other level across the center of the two pads.
 - c) Level the pads by adjusting the four jackscrews in the corners.
- Make sure that the machinist's level readings are as close to zero as possible, both lengthwise and across.

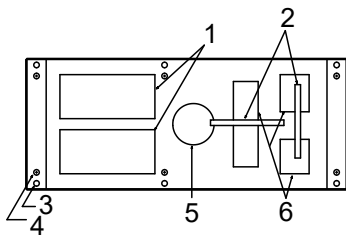

Item	Description
1.	Driver's mounting pads
2.	Machinist's levels
3.	Foundation bolts
4.	Jackscrews
5.	Grout hole
6.	Pump's mounting pads

Figure 18: Level pump mounting pads

6. Hand-tighten the nuts for the foundation bolts.

7. Check that the driver's mounting pads are level and adjust the jackscrews and the foundation bolts if necessary.

The correct level measurement is a maximum of 0.167 mm/m | 0.002 in./ft .

4.2.4 Direct-coupled baseplate

Baseplate-leveling worksheet

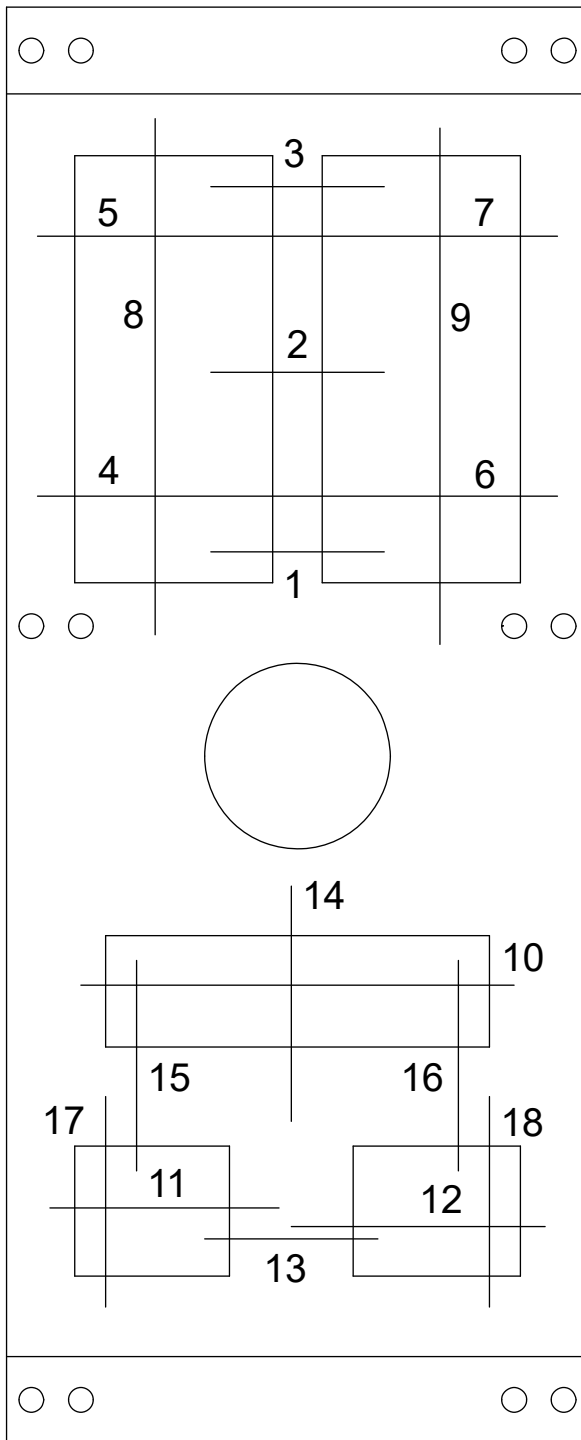

- 1) _____
- 2) _____
- 3) _____
- 4) _____
- 5) _____
- 6) _____
- 7) _____
- 8) _____
- 9) _____
- 10) _____
- 11) _____
- 12) _____
- 13) _____
- 14) _____
- 15) _____
- 16) _____
- 17) _____
- 18) _____

4.3 Install pump, driver, and v-belt drive

4.3.1 Install and align the sheaves

Before installing the driver onto an overhead motor mount or side-by-side base, ensure that Foundation requirements and baseplate mounting procedures sections are complete.



Alignment procedures must be followed to prevent unintended contact of rotating parts. Follow coupling manufacturer's installation and operation procedures.

1. Mount and fasten the pump on the pedestal spacer, foundation, or baseplate as applicable. Use appropriate hardware.
2. For a motor that is mounted overhead, install the overhead motor mount.
3. For a motor that is mounted to the side of the pump, fasten the motor slide base on the baseplate or pump. Fasten the motor slide base on the baseplate or foundation, as applicable. Use appropriate hardware.
4. Mount the driver on the overhead motor mount or slide base, as applicable. Use appropriate hardware.
5. Install the v-belt drive bushings and sheaves. See the installation instructions from the v-belt drive manufacturer.

After the v-belt drive bushings and sheaves are installed, check the sheave alignment using a straight edge as shown in the following diagram.

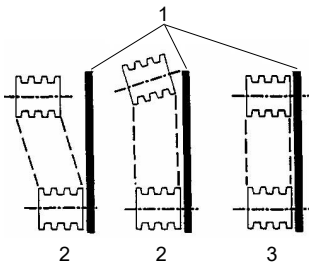

1. Straight edge
2. Incorrect
3. Correct

Figure 19: Sheave alignment

NOTICE:

Make sure that the sheaves are properly aligned. Proper alignment is necessary to guarantee the correct power transmission and speed ratio, and ensures minimum vibration and long drive life.

4.3.2 Install and tension the belt

1. After alignment of the sheaves, reduce the center distance between the pump and motor shafts so that the belts can be easily mounted into the sheave grooves.

For...	Reduce the center distance by...
Overhead mounted motors	Adjusting the leveling nuts

For...	Reduce the center distance by...
Side mounted motors	Adjusting the motor slide base

Make sure that the center distance between the pump and motor shaft is reduced to the point where the belts can be put on the sheaves without the use of force. Never roll or pry the belts into place, as this could damage the belt cords.

2. After the belts are seated in the sheave grooves, increase the center distance between the pump and motor shafts to tension the belts.

Refer to pump general arrangement drawing for center distance ranges.

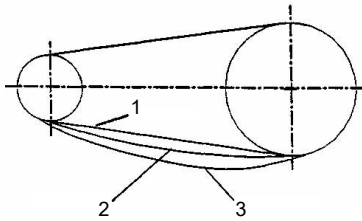

Figure 20: V-belt tension

Many v-belt drive manufacturers offer tension measurement tools that can aid in setting proper belt tension. Contact the v-belt drive manufacturer for more information.

3. Secure the overhead motor mount on slide base in place once the belts are properly tensioned.
4. Install the unit after installation to ensure that the belts and sheaves do not come into contact with the guard.



CAUTION:

The unit must not be operated without the proper drive guard in place. Operating the unit without the drive guard in place could result in personal injury to operating personnel.

4.4 Install the pump, driver, and coupling

1. Mount and fasten the pump on the baseplate. Use applicable bolts.
2. Mount the driver on the baseplate. Use applicable bolts and hand tighten.
3. Install the coupling.
See the installation instructions from the coupling manufacturer.

4.5 Pump-to-driver alignment

Precautions



WARNING:

- Failure to disconnect and lock out driver power may result in serious physical injury or death. Always disconnect and lock out power to the driver before performing any installation or maintenance tasks.
 - Electrical connections must be made by certified electricians in compliance with all international, national, state, and local rules.
 - Refer to driver/coupling/gear manufacturer's installation and operation manuals (IOM) for specific instructions and recommendations.

4.5.1 Alignment checks

When to perform alignment checks

You must perform alignment checks under these circumstances:

- The process temperature changes.
- The piping changes.
- The pump has been serviced.

Types of alignment checks

Type of check	When it is used
Initial alignment (cold alignment) check	Prior to operation when the pump and the driver are at ambient temperature.
Final alignment (hot alignment) check	After operation when the pump and the driver are at operating temperature.

Initial alignment (cold alignment) checks

When	Why
Before you grout the baseplate	This ensures that alignment can be accomplished.
After you grout the baseplate	This ensures that no changes have occurred during the grouting process.
After you connect the piping	This ensures that pipe strains have not altered the alignment. If changes have occurred, you must alter the piping to remove pipe strains on the pump flanges.

Final alignment (hot alignment) checks

When	Why
After the first run	This ensures correct alignment when both the pump and the driver are at operating temperature.
Periodically	This follows the plant operating procedures.

4.5.2 Permitted indicator values for alignment checks

NOTICE:

The specified permitted reading values are valid only at operating temperature. For cold settings, other values are permitted. The correct tolerances must be used. Failure to do so can result in misalignment. Contact ITT for further information.

When dial indicators are used to check the final alignment, the pump and drive unit are correctly aligned when the total indicator runout is a maximum of 0.10 mm | 0.004 in. at operating temperature.

4.5.2.1 Cold settings for parallel vertical alignment

Introduction

This section shows the recommended preliminary (cold) settings for electric motor-driven pumps based on different temperatures of pumped fluid. Consult driver manufacturers for recommended cold settings for other types of drivers such as steam turbines and engines.

Recommended settings for model XHD

Pumped fluid temperature	Recommended setting for driver shaft
10°C 50°F	0.05 mm 0.002 in., low
65°C 150°F	0.03 mm 0.001 in., high
120°C 250°F	0.12 mm 0.005 in., high

4.5.3 Alignment measurement guidelines

Guideline	Explanation
Rotate the pump coupling half and the driver coupling half together so that the indicator rods have contact with the same points on the driver coupling half.	This prevents incorrect measurement.
Move or shim only the driver in order to make adjustments.	This prevents strain on the piping installations.
Make sure that the hold-down bolts for the driver are tight when you take indicator measurements.	This keeps the driver stationary since movement causes incorrect measurement.
Make sure that the hold-down bolts for the driver are loose before you make alignment corrections.	This makes it possible to move the driver when you make alignment corrections.
Check the alignment again after any mechanical adjustments.	This corrects any misalignments that an adjustment may have caused.

4.5.4 Attach the dial indicators for alignment

You must have two dial indicators in order to complete this procedure.

1. Attach two dial indicators on the pump coupling half (X):
 - a) Attach one indicator (P) so that the indicator rod comes into contact with the perimeter of the driver coupling half (Y).
This indicator is used to measure parallel misalignment.
 - b) Attach the other indicator (A) so that the indicator rod comes into contact with the inner end of the driver coupling half.
This indicator is used to measure angular misalignment.

Figure 21: Dial indicator attachment

2. Rotate the pump coupling half (X) in order to check that the indicators are in contact with the driver coupling half (Y) but do not bottom out.
3. Adjust the indicators if necessary.

4.5.5 Pump-to-driver alignment instructions

4.5.5.1 Perform angular alignment for a vertical correction

Before you start this procedure, make sure that the dial indicators are set up correctly.

1. Set the angular alignment indicator to zero at the top-center position (12 o'clock) of the driver coupling half (Y).
A unit is in angular alignment when the angular indicator (A) does not vary by more than 0.10 mm | 0.004 in as measured at 4 points 90° apart at the operating temperature.
2. Rotate the indicator to the bottom-center position (6 o'clock).
3. Record the indicator reading.

When the reading value is...	Then...
Negative	The coupling halves are farther apart at the bottom than at the top. Perform one of these steps: <ul style="list-style-type: none"> • Add shims in order to raise the feet of the driver at the shaft end. • Remove shims in order to lower the feet of the driver at the other end.
Positive	The coupling halves are closer at the bottom than at the top. Perform one of these steps: <ul style="list-style-type: none"> • Remove shims in order to lower the feet of the driver at the shaft end. • Add shims in order to raise the feet of the driver at the other end.

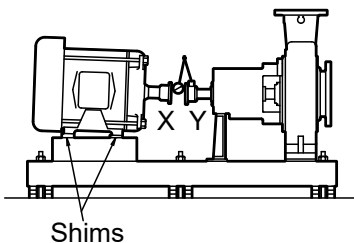

Figure 22: Side view of an incorrect vertical alignment

4. Repeat the previous steps until the permitted reading value is achieved.

4.5.5.2 Perform angular alignment for a horizontal correction

1. Set the angular alignment indicator (A) to zero on left side of the driver coupling half (Y), 90° from the top-center position (9 o'clock).
2. Rotate the indicator through the top-center position to the right side, 180° from the start position (3 o'clock).
3. Record the indicator reading.

When the reading value is...	Then...
Negative	The coupling halves are farther apart on the right side than the left. Perform one of these steps: <ul style="list-style-type: none"> • Slide the shaft end of the driver to the left. • Slide the opposite end to the right.
Positive	The coupling halves are closer together on the right side than the left. Perform one of these steps: <ul style="list-style-type: none"> • Slide the shaft end of the driver to the right. • Slide the opposite end to the left.

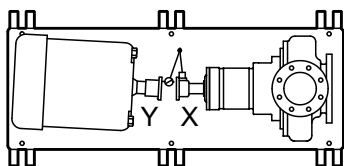

Figure 23: Top view of an incorrect horizontal alignment

4. Repeat the previous steps until the permitted reading value is achieved.

Maximum permitted value for angular alignment:

4.5.5.3 Perform parallel alignment for a vertical correction

Refer to the alignment table in "Permitted indicator values for alignment checks" (see Table of Contents for location of table) for the proper cold alignment value based on the motor temperature rise and the pump operating temperature.

Before you start this procedure, make sure that the dial indicators are correctly set up.

A unit is in parallel alignment when the parallel indicator (P) does not vary by more than 0.10 mm | 0.004 in. as measured at four points 90° apart at the operating temperature.

1. Set the parallel alignment indicator (P) to zero at the top-center position (12 o'clock) of the driver coupling half (Y).
2. Rotate the indicator to the bottom-center position (6 o'clock).
3. Record the indicator reading.

When the reading value is...	Then...
Negative	The pump coupling half (X) is lower than the driver coupling half (Y). Remove shims of a thickness equal to half of the indicator reading value under each driver foot.
Positive	The pump coupling half (X) is higher than the driver coupling half (Y). Add shims of a thickness equal to half of the indicator reading value to each driver foot.

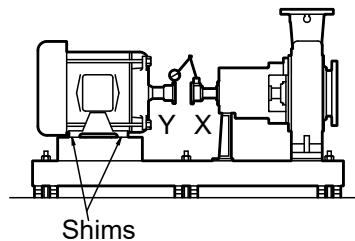

Figure 24: Side view of an incorrect vertical alignment

4. Repeat the previous steps until the permitted reading value is achieved.

NOTICE:

The specified permitted reading values are valid only at operating temperature. For cold settings, other values are permitted. The correct tolerances must be used. Failure to do so can result in misalignment. Contact ITT for further information.

4.5.5.4 Perform parallel alignment for a horizontal correction

Refer to the alignment table in "Permitted indicator values for alignment checks" (see Table of Contents for location of table) for the proper cold alignment value based on the motor temperature rise and the pump operating temperature.

A unit is in parallel alignment when the parallel indicator (P) does not vary by more than 0.10 mm | 0.004 in. as measured at four points 90° apart at the operating temperature.

1. Set the parallel alignment indicator (P) to zero on the left side of the driver coupling half (Y), 90° from the top-center position (9 o'clock).
2. Rotate the indicator through the top-center position to the right side, 180° from the start position (3 o'clock).

- Record the indicator reading.

When the reading value is...	Then...
Negative	The driver coupling half (Y) is to the left of the pump coupling half (X).
Positive	The driver coupling half (Y) is to the right of the pump coupling half (X).

- Slide the driver carefully in the appropriate direction.

NOTICE:

Make sure to slide the driver evenly. Failure to do so can negatively affect horizontal angular correction.

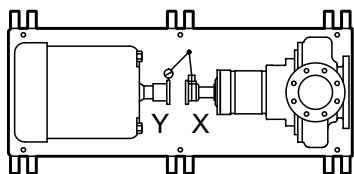

Figure 25: Top view of an incorrect horizontal alignment

- Repeat the previous steps until the permitted reading value is achieved.

NOTICE:

The specified permitted reading values are valid only at operating temperature. For cold settings, other values are permitted. The correct tolerances must be used. Failure to do so can result in misalignment. Contact ITT for further information.

4.5.5.5 Perform complete alignment for a vertical correction

A unit is in complete alignment when both the angular indicator (A) and the parallel indicator (P) do not vary by more than 0.05 mm | 0.002 in. as measured at four points 90° apart.

- Set the angular and parallel dial indicators to zero at the top-center position (12 o'clock) of the driver coupling half (Y).
- Rotate the indicators to the bottom-center position (6 o'clock).
- Record the indicator readings.
- Make corrections according to the separate instructions for angular and parallel alignment until you obtain the permitted reading values.

4.5.5.6 Perform complete alignment for a horizontal correction

A unit is in complete alignment when both the angular indicator (A) and the parallel indicator (P) do not vary by more than 0.10 mm | 0.004 in. as measured at four points 90° apart.

- Set the angular and parallel dial indicators to zero at the left side of the driver coupling half (Y), 90° from the top-center position (9 o'clock).
- Rotate the indicators through the top-center position to the right side, 180° from the start position (3 o'clock).
- Record the indicator readings.
- Make corrections according to the separate instructions for angular and parallel alignment until you obtain the permitted reading values.

4.6 Grout the baseplate

Required equipment:

- Cleaners: Do not use an oil-based cleaner because the grout will not bond to it. See the instructions provided by the grout manufacturer.
 - Grout: Non-shrink grout is recommended.
1. Clean all the areas of the baseplate that will come into contact with the grout.
 2. Build a dam around the foundation.
 3. Thoroughly wet the foundation that will come into contact with the grout.
 4. Pour grout through the grout hole into the baseplate up to the level of the dam.

When you pour the grout, remove air bubbles from it by using one of these methods:

 - Puddle with a vibrator.
 - Pump the grout into place.
 5. Allow the grout to set.

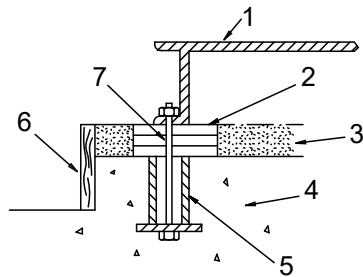

Item	Description
1.	Baseplate
2.	Shims or wedges
3.	Grout
4.	Foundation
5.	Sleeve
6.	Dam
7.	Bolt

Figure 26: Pour grout into baseplate

6. Fill the remainder of the baseplate with grout, and allow the grout to set for at least 48 hours.

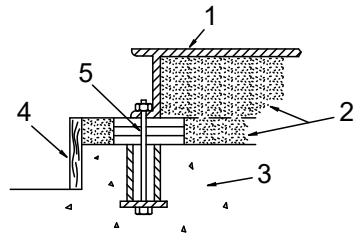

Item	Description
1.	Baseplate
2.	Grout
3.	Foundation
4.	Dam
5.	Bolt

Figure 27: Fill remainder of baseplate with grout

7. Tighten the foundation bolts.
8. Recheck the alignment.

4.7 Piping checklists

4.7.1 General piping checklist

Precautions



WARNING:

- Risk of premature failure. Casing deformation can result in misalignment and contact with rotating parts, causing excess heat generation and sparks. Flange loads from the piping system, including those from the thermal expansion of the piping, must not exceed the limits of the pump.
- Risk of serious personal injury or property damage. Fasteners such as bolts and nuts are critical to the safe and reliable operation of the product. Ensure appropriate use of fasteners during installation or reassembly of the unit.
 - Use fasteners of the proper size and material only.
 - Replace all corroded fasteners.
 - Ensure that all fasteners are properly tightened and that there are no missing fasteners.



CAUTION:

Do not move the pump to the pipe. This could make final alignment impossible.

NOTICE:

Vary the capacity with the regulating valve in the discharge line. Never throttle the flow from the suction side. This action can result in decreased performance, unexpected heat generation, and equipment damage.

Piping guidelines

Guidelines for piping are given in the Hydraulic Institute Standards available from the Hydraulic Institute at 9 Sylvan Way, Parsippany, NJ 07054-3802. You must review this document before you install the pump.

Checklist

Check	Explanation/comment	Checked
Check that all piping is supported independently of, and lined up naturally with, the pump flange.	<ul style="list-style-type: none"> • Strain on the pump • Misalignment between the pump and the drive unit • Wear on the pump bearings and the coupling 	
Keep the piping as short as possible.	This helps to minimize friction losses.	
Keep the piping as straight as possible. Avoid unnecessary bends. Use 45° or long radius 90° fittings where necessary.	This helps to minimize friction losses.	
Check that only necessary fittings are used.	This helps to minimize friction losses.	
Make sure that the inside diameters match properly when you use flange joints.	—	
Do not connect the piping to the pump until: <ul style="list-style-type: none"> • The grout for the baseplate or sub-base becomes hard. • The grout for the pit cover becomes hard. • The hold-down bolts for the pump and the driver are tightened. 	—	
Make sure that all the piping joints and fittings are airtight.	This prevents air from entering the piping system or leaks that occur during operation.	
If the pump handles corrosive fluids, make sure that the piping allows you to flush out the liquid before you remove the pump.	—	
	This helps to prevent misalignment due to linear expansion of the piping.	
Make sure that all piping components, valves and fittings, and pump branches are clean prior to assembly.	—	
Make sure that the isolation and check valves are installed in the discharge line.	Locate the check valve between the isolation valve and the pump. This will permit inspection of the check valve. The isolation valve is required for regulation of flow, and for inspection and maintenance of the pump. The check valve prevents pump or seal damage due to reverse flow through the pump when the driver is turned off.	
Use cushioning devices.	This protects the pump from surges and water hammer if quick-closing valves are installed in the system.	
In no case should loads on the pump flanges exceed the limits stated in API Standard 610, 11th Edition (ISO 13709).	Bottom of casing should be supported by a solid foundation or casing feet should be used.	

Example: Installation for expansion

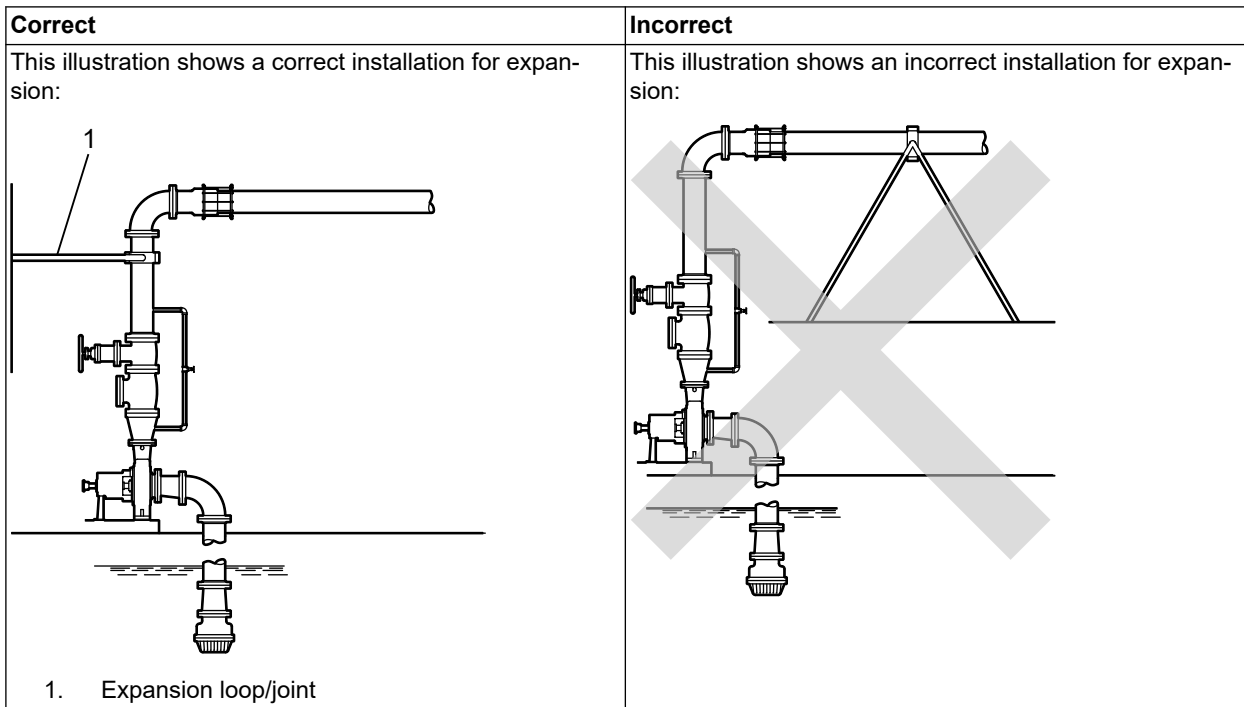

4.7.2 Suction-piping checklist

Performance curve reference

Suction-piping checks

Check	Explanation/comment	Checked
Check that the distance between the inlet flange of the pump and closest flow disruption (elbow, valve, strainer, or expansion joint) is at least five pipe diameters.	This minimizes the risk of cavitation in the suction inlet of the pump due to turbulence.	
Check that elbows in general do not have sharp bends.	See the Example sections for illustrations. —	
<p>Check that the suction piping is one or two sizes larger than the suction inlet of the pump.</p> <p>Install an eccentric reducer between the pump inlet and the suction piping.</p> <p>Suction pipe reducers should have no more than two pipe diameter changes per reducer.</p>	<p>The suction piping must never have a smaller diameter than the suction inlet of the pump.</p> <p>See the Example sections for illustrations.</p>	
<p>Check that the eccentric reducer at the suction flange of the pump has the following properties:</p> <ul style="list-style-type: none"> • Sloping side down • Horizontal side at the top 	See the example illustrations.	

Check	Explanation/comment	Checked
<p>Suggested suction strainers are used. Check that they are at least three times the area of the suction piping.</p> <p>Monitor the pressure drop across the suction strainer.</p> <p>An increased pressure drop across the strainer of 34.5 kPa 5 psi indicates that the strainer should be removed and cleaned.</p> <p>After a period of time (24 hours minimum) system flushing should be complete and the suction strainer can be removed.</p>	<p>Suction strainers help to prevent debris from entering the pump.</p> <p>Mesh holes with a minimum diameter of 1.6 mm 1/16 in. are recommended.</p> <p>Liquids with specific gravity less than 0.60 a pressure drop across the suction strainer may be due to ice buildup. Ice buildup can cause turbulence, low pressure areas and pumpage vaporization.</p>	
<p>If more than one pump operates from the same liquid source, check that separate suction-piping lines are used for each pump.</p>	<p>This recommendation helps you to achieve a higher pump performance and prevent vapor locking especially with specific gravity of liquid less than 0.60.</p>	
<p>If necessary, make sure that the suction piping includes a drain valve and that it is correctly installed.</p>	—	
<p>Assure adequate insulation is applied for liquids with specific gravity less than 0.60.</p>	<p>To assure sufficient NPSHa.</p>	

Liquid source below the pump

Check	Explanation/comment	Checked
<p>Make sure that the suction piping is free from air pockets.</p>	<p>This helps to prevent the occurrence of air and cavitation in the pump inlet.</p>	
<p>Check that the suction piping slopes upwards from the liquid source to the pump inlet.</p>	—	
<p>If the pump is not self-priming, check that a device for priming the pump is installed.</p>	<p>Use a foot valve with a diameter that is at least equivalent to the diameter of the suction piping.</p>	

Liquid source above the pump

Check	Explanation/comment	Checked
<p>Check that an isolation valve is installed in the suction piping at a distance of at least two times the pipe diameter from the suction inlet.</p>	<p>This permits you to close the line during pump inspection and maintenance.</p> <p>Do not use the isolation valve to throttle the pump. Throttling can cause these problems:</p> <ul style="list-style-type: none"> • Loss of priming • Excessive temperatures • Damage to the pump • Voiding the warranty 	
<p>Make sure that the suction piping is free from air pockets.</p>	<p>This helps to prevent the occurrence of air and cavitation in the pump inlet.</p>	
<p>Check that the piping is level or slopes downward from the liquid source.</p>	—	
<p>Make sure that no part of the suction piping extends below the suction flange of the pump.</p>	—	

Check	Explanation/comment	Checked
Make sure that the suction piping is adequately submerged below the surface of the liquid source.	This prevents air from entering the pump through a suction vortex.	

Example: Elbow (or other flow disruption) close to the pump suction inlet

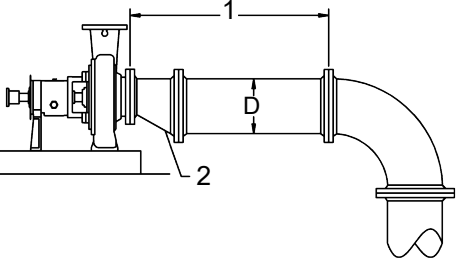
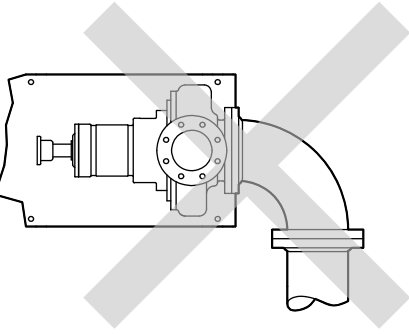
Correct	Incorrect
<p>The correct distance between the inlet flange of the pump and the closest flow disruption (elbow, valve, strainer, or expansion joint) must be a least five pipe diameters.</p>  <p>NOTICE: This illustration shows a correctly installed elbow.</p>	 <p>NOTICE: This illustration shows an incorrectly installed elbow.</p>

Example: Suction piping equipment

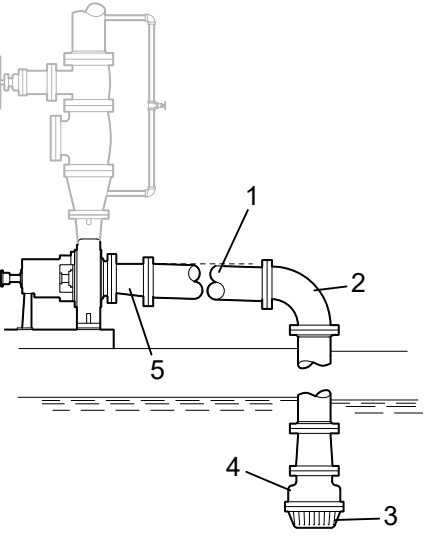
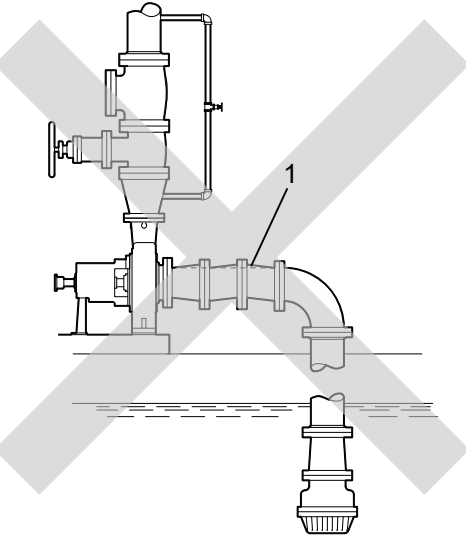
Correct	Incorrect
 <ol style="list-style-type: none"> 1. Suction pipe sloping upwards from liquid source 2. Long-radius elbow 3. Strainer 4. Foot valve 5. Eccentric reducer with a level top <p>NOTICE: This illustration shows correctly installed equipment for the suction piping.</p>	 <ol style="list-style-type: none"> 1. Air pocket, because the eccentric reducer is not used and because the suction piping does not slope gradually upward from the liquid source <p>NOTICE: This illustration shows incorrectly installed equipment for the suction piping.</p>

4.7.3 Discharge piping checklist

Checklist

Check	Explanation/comment	Checked
<p>Check that an isolation valve is installed in the discharge line. For specific gravity less than 0.60, minimize distance from pump discharge.</p>	<p>The isolation valve is required for:</p> <ul style="list-style-type: none"> • Priming • Regulation of flow • Inspection and maintenance of the pump • Reduce risk of pumpage vaporization and vapor locking at low flow rates for low specific gravity liquids. <p>See Example: Discharge piping equipment for illustrations.</p>	

Check	Explanation/comment	Checked
Check that a check valve is installed in the discharge line, between the isolation valve and the pump discharge outlet.	The location between the isolation valve and the pump allows inspection of the check valve. The check valve prevents damage to the pump and seal due to the back flow through the pump, when the drive unit is shut off. It is also used to restrain the liquid flow. See Example: Discharge piping equipment for illustrations.	
If increasers are used, check that they are installed between the pump and the check valve.	See Example: Discharge piping equipment for illustrations.	
If quick-closing valves are installed in the system, check that cushioning devices are used.	This protects the pump from surges and water hammer.	

Example: Discharge piping equipment

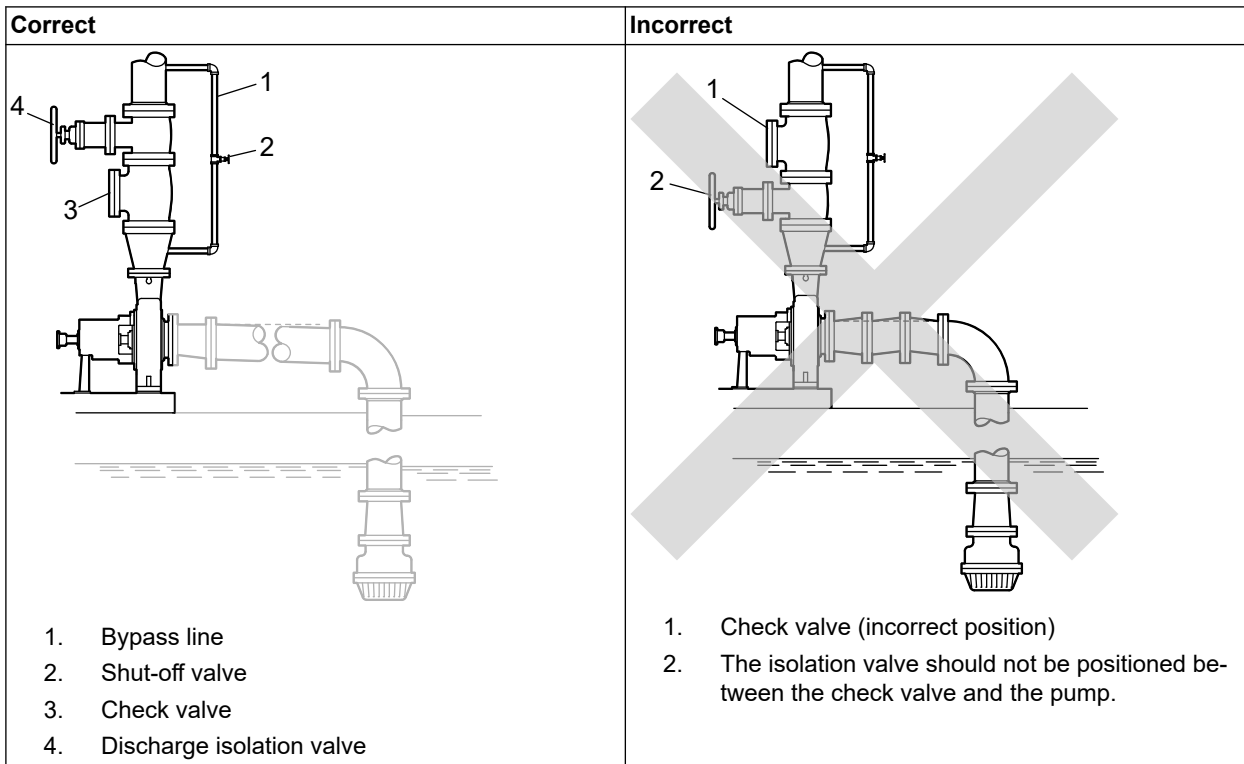

4.7.4 Bypass-piping considerations

When to use a bypass line

Provide a bypass line for systems that require operation at reduced flows for prolonged periods. Connect a bypass line from the discharge side (before any valves) to the source of suction.

When to install a minimum-flow orifice

You can size and install a minimum-flow orifice in a bypass line in order to prevent bypassing excessive flows. Consult your ITT representative for assistance in sizing a minimum-flow orifice.

When a minimum-flow orifice is unavailable

Consider an automatic recirculation control valve or solenoid-operated valve if a constant bypass (minimum-flow orifice) is not possible.

4.7.5 Auxiliary-piping checklist**Precautions****NOTICE:**

- Auxiliary cooling and flush systems must be operating properly to prevent excess heat generation, sparks, and/or premature failure. Ensure auxiliary piping is installed as specified on the pump data sheet prior to startup.

When to install

You may need to install auxiliary piping for bearing cooling, seal-chamber cover cooling, mechanical seal flush, or other special features supplied with the pump. Consult the pump data sheet for specific auxiliary piping recommendations.

Checklist

Check	Explanation/comment	Checked
Check that the minimum flow for each component is 4 lpm 1 gpm. If the bearing and seal chamber cover cooling are provided, then the auxiliary piping must flow at 8 lpm 2 gpm.	–	
Check that the cooling water pressure does not exceed 7.0 kg/cm ² 100 psig .	–	

4.7.6 Final piping checklist

Check	Explanation/comment	Checked
Check that the shaft rotates smoothly.	Rotate the shaft by hand. Make sure there is no rubbing that can lead to excess heat generation or sparks.	
Re-check the alignment to make sure that pipe strain has not caused any misalignment.	If pipe strain exists, then correct the piping.	

5 Commissioning, Startup, Operation, and Shutdown

5.1 Preparation for startup



WARNING:

- Risk of serious physical injury or death. Exceeding any of the pump operating limits (e.g. - pressure, temperature, power, etc.) could result in equipment failure, such as explosion, seizure, or breach of containment. Assure that the system operating conditions are within the capabilities of the pump.
- Risk of death or serious injury. Leaking fluid can cause fire and/or burns. Ensure all openings are sealed prior to filling the pump.
- Breach of containment can cause fire, burns, and other serious injury. Failure to follow these precautions before starting the unit may lead to dangerous operating conditions, equipment failure, and breach of containment.
- Risk of explosion and serious physical injury. Do not operate pump with blocked system piping or with suction or discharge valves closed. This can result in rapid heating and vaporization of pumpage.



- The impeller clearance setting procedure must be followed. Improperly setting the clearance or not following any of the proper procedures can result in sparks, unexpected heat generation, and equipment damage.



- When installing in a potentially explosive environment, make sure that the motor is properly certified and that all equipment is installed in accordance with instructions for that environment.
- Risk of breach of containment and equipment damage. Ensure the pump operates only between minimum and maximum rated flows. Operation outside of these limits can cause high vibration, mechanical seal and/or shaft failure, and/or loss of prime.

**WARNING:**

- Risk of death, serious personal injury, and property damage. Heat and pressure buildup can cause explosion, rupture, and discharge of pumpage. Never operate the pump with suction and/or discharge valves closed.
- Running a pump without safety devices exposes operators to risk of serious personal injury or death. Never operate a unit unless appropriate safety devices (guards, etc.) are properly installed.
- Failure to disconnect and lock out driver power may result in serious physical injury or death. Always disconnect and lock out power to the driver before performing any installation or maintenance tasks.
 - Electrical connections must be made by certified electricians in compliance with all international, national, state, and local rules.

- Refer to driver/coupling/gear manufacturer's installation and operation manuals (IOM) for specific instructions and recommendations.
- Risk of seizure, breach of containment, or explosion. Ensure balance line is installed and piped back to either the pump suction or suction vessel. This prevents rapid vaporization of the pumped fluid.

Precautions



WARNING:

The mechanical seal used in an Ex-classified environment must be properly certified.



CAUTION:

When a cartridge mechanical seal is used, ensure that the set screws in the seal locking ring are tightened and that the centering clips have been removed prior to startup. This prevents seal or shaft sleeve damage by ensuring that the seal is properly installed and centered on the sleeve.

NOTICE:

- Verify the driver settings before you start any pump. Refer to the applicable drive equipment IOMs and operating procedures.
 - Excessive warm-up rates can cause equipment damage. Ensure the warm-up rate does not exceed 1.4°C | 2.5°F per minute.
-

NOTICE:

You must follow these precautions before you start the pump:

- Flush and clean the system thoroughly to remove dirt or debris in the pipe system in order to prevent premature failure at initial startup.
 - Bring variable-speed drivers to the rated speed as quickly as possible.
 - If temperatures of the pumped fluid will exceed 93°C | 200°F, then warm up the pump prior to operation. Circulate a small amount of fluid through the pump until the casing temperature is within 38°C | 100°F of the fluid temperature. Accomplish this by flowing fluid from pump inlet to discharge drain (optionally, the casing vent can be included in warm-up circuit but not required). Soak for (2) hours at process fluid temperature.
-

At initial startup, do not adjust the variable-speed drivers or check for speed governor or over-speed trip settings while the variable-speed driver is coupled to the pump. If the settings have not been verified, then uncouple the unit and refer to instructions supplied by the driver manufacturer.

After observing the precautions above, the v-belt or coupling guard must be removed to check driver rotation and set the impeller clearance. Refer to the appropriate guard removal instructions specific to your unit(s).

5.2 Remove the V-belt drive guard

1. Remove the drive guard assembly hardware as appropriate.
2. Remove the hardware that secures the drive guard in place.
3. Disassemble and remove the drive guard assembly.

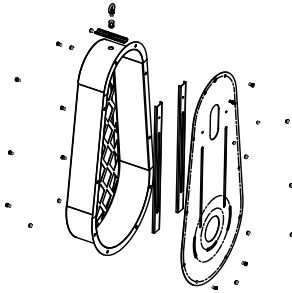
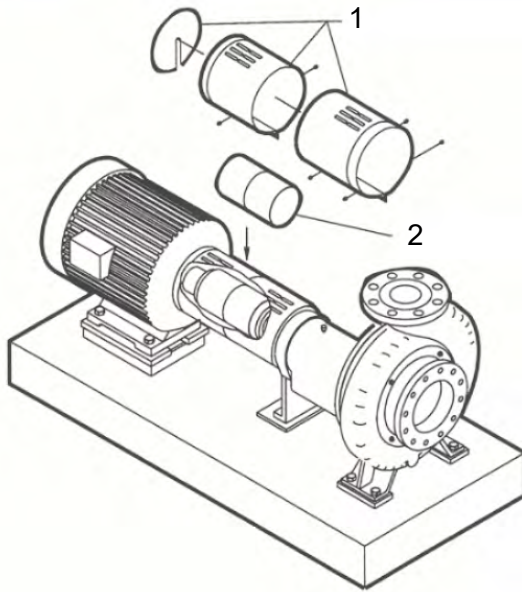

Figure 28: Belt guard removal

5.3 Remove the coupling guard

1. Remove the nut, bolt, retainer and washer from the slotted hole in the center of the coupling guard.
2. Slide the driver half of the coupling guard toward the pump.
3. Remove the nut, bolt, retainer and washer from the driver half of the coupling guard.
4. Remove the driver half of the coupling guard:
 - a) Slightly spread the bottom apart.
 - b) Lift upwards.
5. Remove the remaining nut, bolt, retainer and washer from the pump half of the coupling guard. It is not necessary to remove the end plate from the pump side of the bearing housing. You can access the bearing-housing tap bolts without removing this end plate if maintenance of internal pump parts is necessary.
6. Remove the pump half of the coupling guard:
 - a) Slightly spread the bottom apart.
 - b) Lift upwards.



Item	Description
1.	Coupling guard
2.	Coupling

5.4 Check the rotation



WARNING:

- Starting the pump in reverse rotation can result in the contact of metal parts, heat generation, and breach of containment. Ensure correct driver settings prior to starting any pump.
- Failure to disconnect and lock out driver power may result in serious physical injury or death. Always disconnect and lock out power to the driver before performing any installation or maintenance tasks.
 - Electrical connections must be made by certified electricians in compliance with all international, national, state, and local rules.
 - Refer to driver/coupling/gear manufacturer's installation and operation manuals (IOM) for specific instructions and recommendations.



WARNING:

The coupling used in an ATEX classified environment must be properly certified.

1. Lock out power to the driver.
2. Make sure that the coupling hubs or v-belt sheaves are fastened securely to the shafts.
3. Make sure that the coupling spacer is removed, if applicable.
The pump ships with the coupling spacer removed.
4. Unlock power to the driver.
5. Make sure that everyone is clear, and then jog the driver long enough to determine that the direction of rotation corresponds to the arrow on the bearing housing or casing.
6. Lock out power to the driver.

5.5 Impeller-clearance check

The impeller-clearance check ensures the following:

- The pump turns freely.
- The pump operates at optimal efficiency for long equipment life and low energy consumption.

5.5.1 Impeller axial clearances

Total axial adjustment

NOTICE:



Service temperature in an Ex classified environment is limited to the area classification specified on the Ex tag to the pump.

(refer to ATEX classifications) [1.3 Product approval standards on page 10](#).

The total axial adjustment of the impeller between the suction seal ring and the stuffing box cover should be as noted in the chart below.

Impeller clearance (total travel)

Pump size	Impeller Maximum Total Clearance mm inches	Impeller Minimum Total Clearance mm inches
XHD50	9.4 0.37	2.0 0.08
XHD75	9.4 0.37	2.0 0.08
XHD80	9.4 0.37	2.0 0.08
XHD100	9.8 0.39	2.0 0.08
XHD125	9.8 0.39	2.0 0.08
XHD150	10.8 0.43	3.3 0.13
XHD200	11.8 0.47	4.1 0.16
XHD250	11.9 0.47	4.0 0.16
XHD300	12.8 0.51	4.6 0.18

5.6 Impeller-clearance setting

Importance of a proper impeller clearance

A proper impeller clearance ensures that the pump runs at high performance.

NOTICE:

Set the cold (ambient) impeller clearance according to [Table 9: Impeller clearance - Metal-lined on page 56](#), [Table 10: Impeller clearance - Rubber-lined on page 56](#) and [Table 11: Field setting impeller back clearance with an expeller - Metal-lined assemblies on page 56](#). Failure to do so may result in heat generation and equipment damage. Higher clearances are used above 93°C | 200°F to prevent the impeller from contacting the casing due to thermal expansion.

**WARNING:**

The impeller clearance setting procedure must be followed. Improperly setting the clearance or not following any of the proper procedures can result in sparks, unexpected heat generation, and equipment damage.

**WARNING:**

- The pump should be run for a period of 15 minutes to verify the impeller is properly tightened onto the shaft. In addition to verifying the impeller is properly tightened, it is necessary to verify that the bearing frame adjustment plate bolts (352G) and nuts (427D) are properly secured and tight. Failure to check that the impeller is tight and the bearing frame adjustment plate bolts and nuts are properly tightened can result in the rotating element shifting during operation.

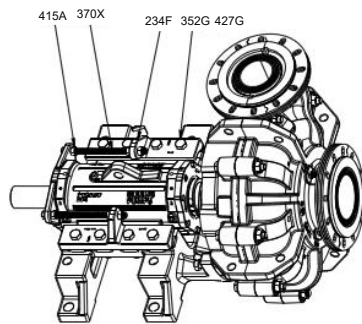

Figure 29: Securing the bearing frame adjustment plate

- Risk of mechanical seal damage leading to breach of containment. If a cartridge mechanical seal is used, ensure that the set screws in the seal locking ring are loosened and that the centering clips have been installed prior to clearance adjustment.

The front clearance is set at .51 mm (0.020 in) at the factory but could change due to piping attachment during installation. A change in pump performance may be noted over time by a drop in head or flow or an increase in power required.

Table 8: Impeller clearance methods

The XHD and XHD Value Option models have different methods of setting the impeller clearance.

Pump Model	Method
XHD	<p>The impeller clearance is set by measuring the gap between the rear shroud of the impeller and the casing volute liner, and measuring the gap between the front of the impeller and the suction seal ring clearance.</p> <p>Skip to the "Set Impeller to Suction seal Ring Clearance Dial Indicator Method - XHD" step.</p> <p>After impeller rear clearance has been set on the XHD, the suction seal ring clearance must also be set.</p>
XHD Value Option	<p>The impeller clearance is set by measuring the gap between the front of the impeller and the suction side liner. Use the "Set the impeller clearance dial indicator method - XHD Value Option" step. All units that do not have the Adjustable Suction Seal Ring as part of the assembly are set via this method.</p>

5.6.1 Set impeller to Suction Seal Ring Clearance Dial Indicator Method



WARNING:

Failure to disconnect and lock out driver power may result in serious physical injury or death. Always disconnect and lock out power to the driver before performing any installation or maintenance tasks.

- Electrical connections must be made by certified electricians in compliance with all international, national, state, and local rules.
- Refer to driver/coupling/gear manufacturer's installation and operation manuals (IOM) for specific instructions and recommendations.



- The impeller clearance setting procedure must be followed. Improperly setting the clearance or not following any of the proper procedures can result in sparks, unexpected heat generation, and equipment damage.

NOTICE:

In order to use this method for setting the impeller clearance, the unit must be assembled with the Adjustable Suction Seal Ring. For units assembled without the adjustable suction seal ring, skip this section and refer to: [5.6.2 Set impeller clearance dial indicator method - XHD on page 57](#)

All of the instructions that are stated in the following steps are based on viewing the unit from the rearward (drive) end.

1. Remove the coupling or v-belt guard.
2. Loosen the two adjusting nuts (415A) on the forward sides of the bearing frame adjustment plates (234F) by turning them counterclockwise. This will temporarily hold the frame in place until step 15 is completed.
3. Loosen but do not remove the adjustment plate hold-down bolts (352G) and nuts (427D) that clamp the bearing frame adjustment plates (234F) to the pedestal (131). Do not remove the adjustment plate hardware. Keep hardware finger tight to keep the power frame constrained to the pedestal.
4. Back up the Impeller: Turn the two adjusting nuts (415A) on the rearward sides of the bearing frame adjustment plates (234F) counterclockwise sequentially, 1/2 of a turn each at a time, to draw the power end and impeller (101) backward until the face of the rear pump out vanes of the impeller contacts the volute liner (561). Turn the shaft (122) clockwise to ensure that there is contact between the impeller (101) and volute liner (561). Stop turning the adjusting nuts (415A) when a firm drag is encountered.
5. Place and zero the indicator: Place the dial indicator so that the button contacts either the shaft end, face of the coupling, face of the sheave bushing, or on the face of the bearing end cover. Zero the indicator.
6. Loosen the two adjusting nuts (415A) on the rear sides of the bearing frame adjustment plates (234F) that were tightened in step 4 above by turning them counter clockwise.
7. Move Impeller forward the sum of impeller back clearance plus the impeller front clearance from table 7: Turn the two adjusting nuts (415A) on the forward sides of the bearing frame adjustment plates (234F) clockwise sequentially, 1/2 of a turn at a time, to draw the power end forward until there is a 2.54mm (.100 in) or 3.0 mm (.118 in) gap between the impeller (101) and suction volute liner (561) as measured on the dial indicator.
8. Tighten the adjustment plate hold-down bolts (352G) and nuts (427D) that clamp the bearing frame adjustment plates (234F) to the pedestal (131). Make sure that the dial indicator reading remains at the proper setting. This will temporarily hold the frame in place until step 15 is completed.
9. Loosen the three seal ring jam nuts (357B) by turning them counterclockwise.

10. Move Seal Ring to contact to the impeller: Turn the three square head adjusting bolts (356F) sequentially counter clockwise, 1/3 of a turn each at a time, until the seal ring (822) contacts the impeller (101) and is square with the wear surface of the impeller. Turn the shaft (122) clockwise while performing step 10 to ensure there is contact between the seal ring (822) and impeller (101). Stop turning the square head adjusting bolts (356F) when a firm drag is encountered.
11. Tighten the seal ring adjusting bolt jam nuts (357B) by turning counterclockwise until the nuts contact the suction casing (100A).
12. Loosen the adjustment plate hold down bolts (352G) and nuts (427D).
13. Loosen the two adjusting nuts (415A) on the forward sides of the bearing frame adjustment plates (234F) by turning them counterclockwise.
14. Back up the impeller .51mm | 0.020 in: Turn the two adjusting nuts (415A) on the rearward sides of the bearing frame adjustment plates (234F) sequentially clockwise, 1/2 of a turn each at a time, to draw the power end backward until the impeller (101) dial indicator measures the proper field setting impeller back clearance from table 7. To verify the correct impeller to suction seal ring clearance has been made, a feeler gage can be inserted thru the casing suction between the impeller (101) and seal ring (822) in 3 places to assure the seal ring is square to the impeller face.
15. Tighten the adjustment plate hold-down bolts (352G) and nuts (427D) that clamp the bearing frame adjustment plates (234F) to the pedestal (131). Make sure that the dial indicator reading remains at the proper setting.

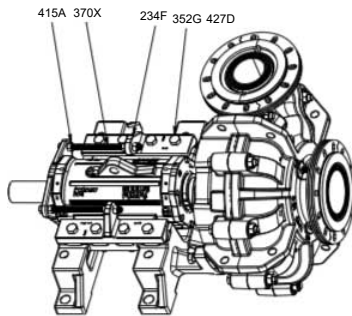

Figure 30: Tighten frame adjustment plate hold down bolts

NOTICE:

It is critical that adjustment plate hold down bolts (352G) and nuts (427D) are properly torqued to prevent the power frame from moving during operation.

16. Tighten the two adjusting nuts (415A) on the forward side of the bearing frame adjustment plates (234F) by turning counterclockwise until they contact the adjustment plates.

This procedure should yield .51mm | 0.02in gap between the impeller (101) and suction seal ring (822), and leave the approximate back clearance noted in table 7 gap between the rear shroud of the impeller (101) and the volute liner (561).

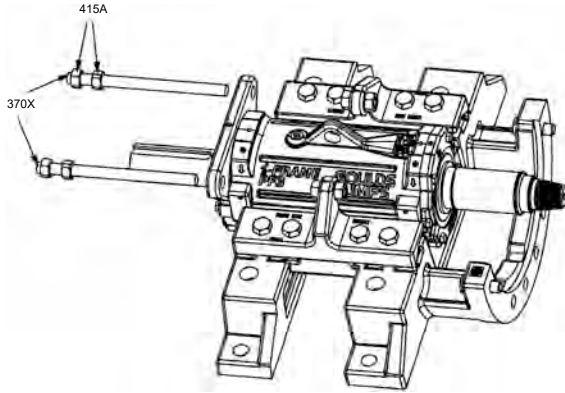

Figure 31: Frame adjusting bolt assembly

Table 9: Impeller clearance - Metal-lined

Pump Size	Field Setting Impeller Back Clearance mm inches	Field Setting Impeller Front Clearance mm inches
XHD50	NA	0.51 0.02
XHD75	NA	0.51 0.02
XHD80	2 0.08	0.51 0.02
XHD100	2 0.08	0.51 0.02
XHD125	2 0.08	0.51 0.02
XHD150	2 0.08	0.51 0.02
XHD200	2.5 0.1	0.51 0.02
XHD250	2.5 0.1	0.51 0.02
XHD300	2.5 0.1	0.51 0.02

Table 10: Impeller clearance - Rubber-lined

Pump Size	Field Setting Impeller Front Clearance mm inches
XHD50	0.75 0.03
XHD75	0.75 0.03
XHD80	0.75 0.03
XHD100	0.75 0.03
XHD125	0.75 0.03
XHD150	0.75 0.03
XHD200	0.75 0.03

NOTICE:

Currently rubber lined assemblies are configured only with single piece suction liners. Impeller adjustment is only accomplished via adjusting the frame adjusting bolts.

Table 11: Field setting impeller back clearance with an expeller - Metal-lined assemblies

Pumps that have the dynamic seal option require different impeller running clearances to maximize expeller performance. Refer to the table below for running clearances for pumps with expeller.

Pump Size	Field Setting Impeller Back Clearance mm inches	Field Setting Impeller Seal Ring Clearance mm inches
XHD50	NA	0.51 0.02

Pump Size	Field Setting Impeller Back Clearance mm inches	Field Setting Impeller Seal Ring Clearance mm inches
XHD75	NA	0.51 0.02
XHD80	1.02 0.04	0.51 0.02
XHD100	1.02 0.04	0.51 0.02
XHD125	1.52 0.06	0.51 0.02
XHD150	1.52 0.06	0.51 0.02
XHD200	1.52 0.06	0.51 0.02
XHD250	2.03 0.08	0.51 0.02
XHD300	2.03 0.08	0.51 0.02

5.6.2 Set impeller clearance dial indicator method - XHD



WARNING:

Failure to disconnect and lock out driver power may result in serious physical injury or death. Always disconnect and lock out power to the driver before performing any installation or maintenance tasks.

- Electrical connections must be made by certified electricians in compliance with all international, national, state, and local rules.
- Refer to driver/coupling/gear manufacturer's installation and operation manuals (IOM) for specific instructions and recommendations.

NOTICE:

- For rubber lined assemblies, refer to steps 1-10 that follow.
- The Suction seal ring option is under currently development.
- Refer to *Impeller clearance - Rubber-Lined* table to define the impeller front clearance setting.

All of the instructions that are stated in the following steps are based on viewing the unit from the rearward (drive) end.

1. Remove the coupling or v-belt guard.
2. Loosen the two adjusting nuts (415A) on the forward sides of the bearing frame adjustment plates (234F) by turning them clockwise.
3. Loosen but do not remove the adjustment plate hold-down bolts (352G) and nuts (427D) that clamp the bearing frame adjustment plates (234F) to the pedestal (131). Do not remove the adjustment plate hardware. Keep hardware finger tight to keep the power frame constrained to the pedestal.
4. Turn the two adjusting nuts (415A) on the forward sides of the bearing frame adjustment plates (234F) sequentially clockwise, 1/2 of a turn each at a time, to draw the power end forward until the impeller (101) contacts the Suction Liner (562).
5. Turn the shaft (122) clockwise while performing step 4 above to ensure that there is contact between the impeller (101) and Suction Liner (562). Stop turning the forward adjusting nuts when a firm drag is encountered.
6. Place the dial indicator so that the button contacts either the shaft end, face of the coupling, or face of the sheave bushing or the face of the bearing end cover. Zero the indicator.
7. Turn the two adjusting nuts (415A) on the rear sides of the bearing frame adjustment plates (234F) sequentially counterclockwise, 1/2 of a turn each at a time, to draw the power end and impeller (101) backward until there is an approximate 0.02 inch (.50 mm) gap between the impeller (101) and suction liner (562) as measured on the dial indicator.

8. Tighten the adjustment plate hold-down bolts (352G) and nuts (427D) that clamp the bearing frame adjustment plates (234F) to the pedestal (131). Make sure that the dial indicator reading remains at the proper setting.
9. Tighten the two adjusting nuts (415A) on the rearward side of the bearing frame adjustment plates (234F) that were loosened in step 5 above by turning them clockwise. Make sure that the dial indicator reading remains at the proper setting.

NOTICE:

It is critical that adjustment plate hold down bolts (352G) and nuts (427D) are properly torqued to prevent the power frame from moving during operation.

10. Replace the coupling or v-belt guard.

5.6.3 Suction seal ring clearance check - XHD only



WARNING:

Failure to disconnect and lock out driver power may result in serious physical injury or death. Always disconnect and lock out power to the driver before performing any installation or maintenance tasks.

- Electrical connections must be made by certified electricians in compliance with all international, national, state, and local rules.
 - Refer to driver/coupling/gear manufacturer's installation and operation manuals (IOM) for specific instructions and recommendations.
-

In addition to checking the impeller clearance, the suction seal ring clearance on the XHD model must also be checked according to the following instructions for optimal efficiency and wear.

All of the instructions that are stated in the following steps are based on viewing the unit from the rearward (drive) end.

1. Loosen the three seal ring jam nuts (357B) by turning them counterclockwise.
2. Turn the three square head adjusting bolts (356F) sequentially clockwise, 1/3 of a turn each at a time, until the seal ring (822) contacts the impeller (101).
3. Turn the shaft (122) clockwise while performing step 2 above to ensure there is contact between the seal ring (822) and impeller (101). Stop turning the square head adjusting bolts when a firm drag is encountered.
4. Turn the three square head adjusting bolts (356F) sequentially counterclockwise, 1/3 of a turn each at a time, while measuring the gap between the impeller (101) and seal ring (822) using a set of feeler gauges inserted in the suction of the pump.
5. Continue adjusting the square head adjusting bolts as outlined in step 3 above until there is the appropriate gap from table 7 between the suction seal ring (822) and the impeller (101). The gap is properly established when a appropriate feeler gauge fits snugly into the space between the impeller (101) and seal ring (822).
6. Lock the square head adjusting bolts (356F) in place by turning the jam nuts (357B) clockwise until tightened against the suction half casing (100A).

After the clearances have been checked/set, the v-belt or coupling guard can be re-installed. Refer to the appropriate guard installation instructions specific to your unit(s).

Impeller to Suction liner / Seal Ring Front clearance
0.02 inches
0.50 mm

5.7 Install the V-belt drive guard



WARNING:

The driver guard used in an Ex classified environment must be constructed from a spark resistant material.

1. Assemble the drive guard as necessary. Use appropriate hardware.
2. Secure the drive guard in place to the foundation or baseplate and pump as necessary. Use appropriate hardware.

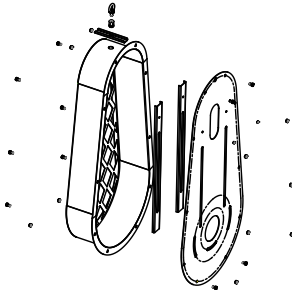

Figure 32: V-belt drive guard

5.8 V-Belt drive operation

5.8.1 V belt drive installation checks

Use the following steps and guidelines to make sure that the v-belt drive is properly installed and that the belts are properly tensioned.

1. Operate the drive for a few minutes as the belts seat into the sheave grooves.
2. Observe the operation of the drive under its highest load condition, which is usually at startup.
3. A slight bowing of the slack side of the drive indicates proper tension.
4. The following indicate improper belt tensioning:
 - a) If the slack side of the drive remains too taut during peak load, the drive is too tight.
 - b) Excessive bowing or slippage of the slack side indicates insufficient tension.
 - c) If the belts squeal as the motor is started, or at some subsequent peak load, the belts are not tight enough to deliver the torque that is demanded by the motor.
5. If any of the conditions that are listed under (4) are evident, stop the drive and readjust the belts.
6. If conditions persist, check the sheave alignment as outlined in the previous sections.
7. The belt tension on a newly installed drive should be checked throughout the first day of continuous operation by observing the slack side span. After a few days of operation, the belts will fully seat themselves in the sheave grooves, and further readjustment may be necessary. Use the steps and guidelines above as necessary.

5.8.2 V-belt drive monitoring and protection

1. Use all of the information in these sections to ensure that the v-belt drive is properly installed for correct operation and long life.
2. Keep the v-belts clean. Exposure to dirt and grease can reduce belt life. Maintaining a clean drive is the one of the best practices a user can employ to ensure drive longevity.
3. Always follow safety procedures. Never adjust any components of the v-belt drive while the unit is in operation.

4. Always observe v-belt running operation through the mesh portions of the drive guard at a safe distance.
5. Always keep all appendages, clothing, and site tooling out of reach while the drive is running. Failure to do so could result in personal injury and unit damage.
6. Never run the unit without the drive guard in place.

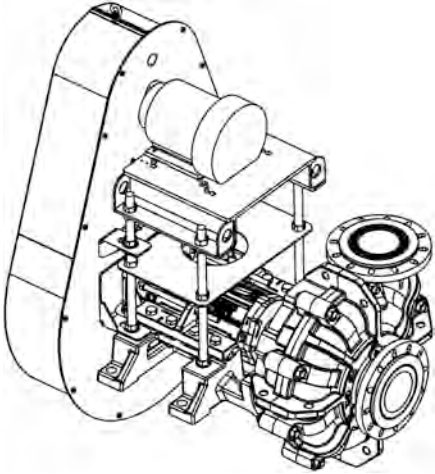

Figure 33: Pump with OHMM and belt guard installed

5.9 Couple the pump and driver



WARNING:

Failure to disconnect and lock out driver power may result in serious physical injury or death. Always disconnect and lock out power to the driver before performing any installation or maintenance tasks.

- Electrical connections must be made by certified electricians in compliance with all international, national, state, and local rules.
 - Refer to driver/coupling/gear manufacturer's installation and operation manuals (IOM) for specific instructions and recommendations.
-



Couplings must have proper certification to be used in an Ex classified environment. Use the instructions from the coupling manufacturer in order to lubricate and install the coupling. Refer to driver/coupling/gear manufacturers IOM for specific instructions and recommendations.

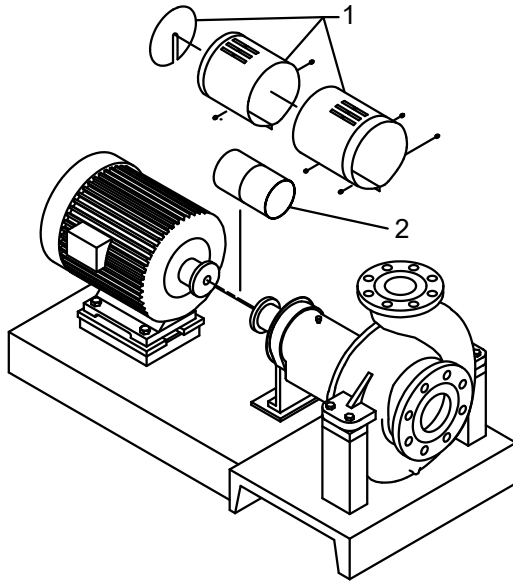

1. Coupling guard
2. Coupling

Figure 34: Coupling guard assembly

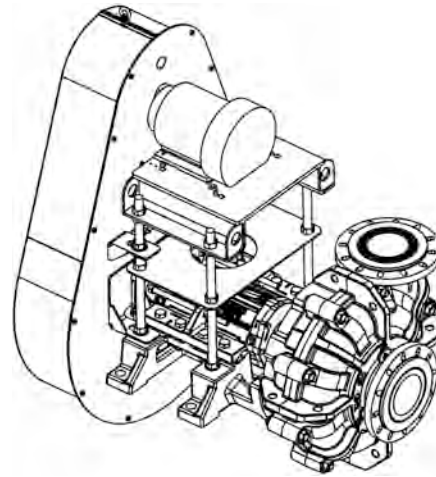

Figure 35: Pump with OHMM and belt guard installed

5.9.1 Install the coupling guard



WARNING:

- Running a pump without safety devices exposes operators to risk of serious personal injury or death. Never operate a unit unless appropriate safety devices (guards, etc.) are properly installed.
- Failure to disconnect and lock out driver power may result in serious physical injury or death. Always disconnect and lock out power to the driver before performing any installation or maintenance tasks.
 - Electrical connections must be made by certified electricians in compliance with all international, national, state, and local rules.
 - Refer to driver/coupling/gear manufacturer's installation and operation manuals (IOM) for specific instructions and recommendations.



WARNING:

The coupling guard used in an Ex classified environment must be properly certified and constructed from a spark resistant material.

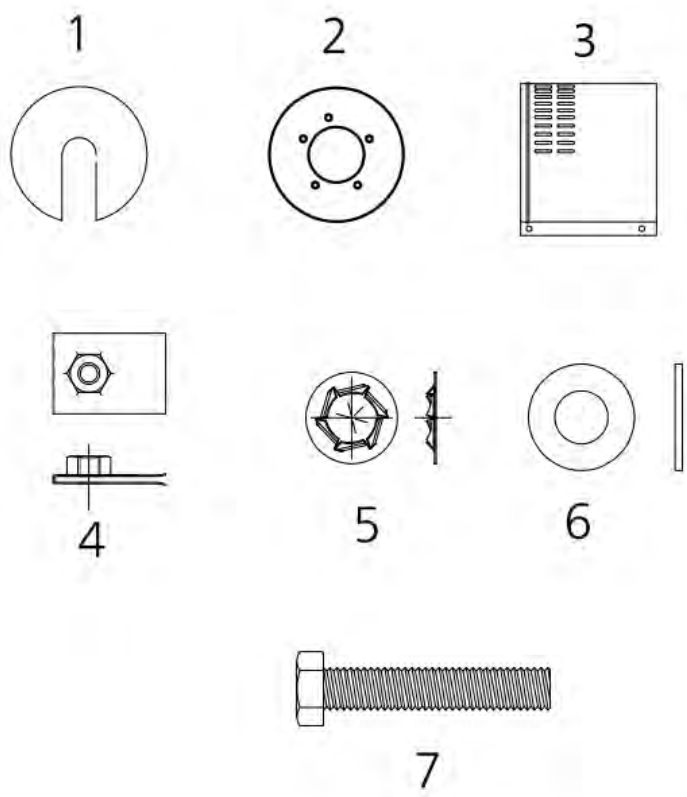

Part No.	Description	Part No.	Description
1	Cover driver	5	Retainer (Qty 3)
2	Cover pump	6	Washer (Qty 4)
3	Guard (Qty 2)	7	Hex head bolt (Qty 3)
4	U-nut (Qty 3)		

Figure 36: Required parts

1. De-energize the motor, place the motor in a locked-out position, and place a caution tag at the starter that indicates the disconnect.
2. Put the pump-side end plate in place.
If the pump-side end plate is already in place, make any necessary coupling adjustments and then proceed to the next step.
3. Slightly spread the opening of the coupling guard half and place it over the pump end plate.
 - a) The annular groove in the guard is located around the end plate.
 - b) Position the opening (flange) so that it does not interfere with the piping but still allows for access when you install the bolts.

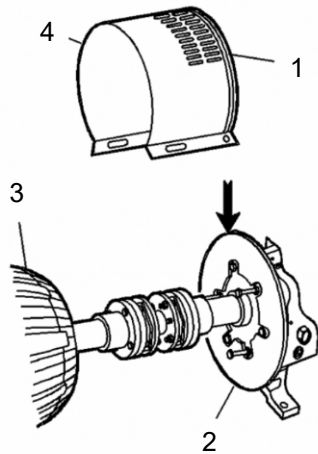

Item	Description
1.	Annular groove
2.	Pump-side end plate
3.	Driver
4.	Pump half of the coupling guard

Figure 37: Align pump end guard half with annular groove

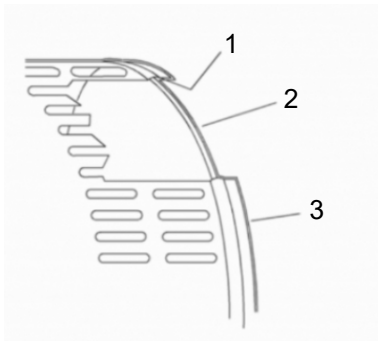

Item	Description
1.	Annular groove
2.	End plate (pump end)
2.	Guard half

Figure 38: Annular groove in coupling guard

4. Place one washer over the bolt and insert the bolt through the round hole at the front end of the guard half.

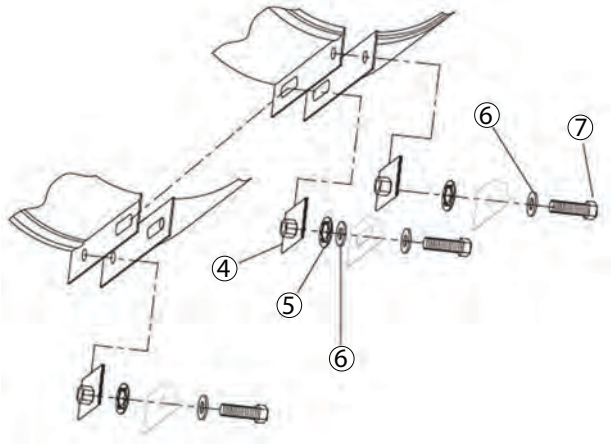

Figure 39: Captured hardware component assembly

5. Install the bolt retainer over the exposed end of the bolt, and the U-Nut into the slot in the coupling guard if it was not done from the factory.
6. Thread bolt into the U-Nut and tighten firmly.
7. Slightly spread the opening of the remaining coupling guard half and place it over the installed coupling guard half so that the annular groove in the remaining coupling guard half faces the motor.

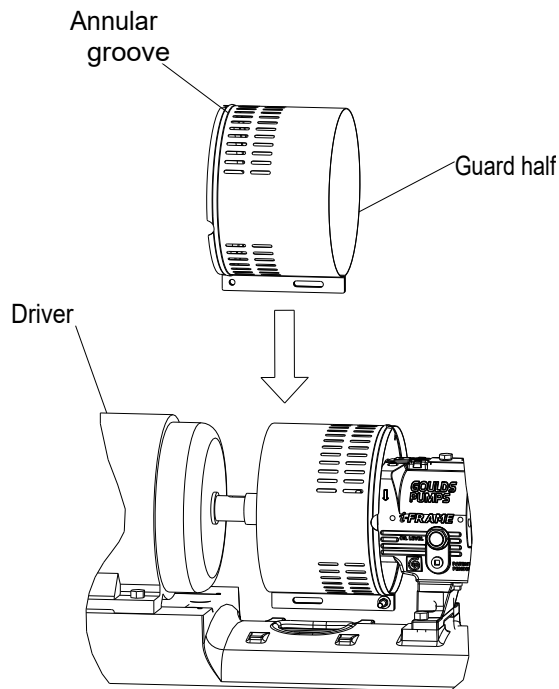

Figure 40: Placement of driver half of coupling guard

8. Place the end plate over the driver shaft and locate the end plate in the annular groove at the rear of the coupling guard half.

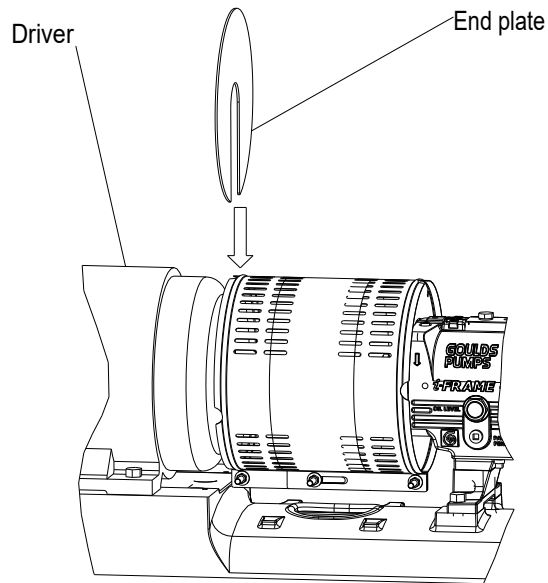

Figure 41: Placement of driver half of coupling guard

9. Hand-tighten only. Repeat Steps 4 through 6 for the rear end of the coupling guard half. The hole is located on the driver-side of the coupling guard half.
10. Slide the driver-half of the coupling guard towards the motor so that the coupling guard completely covers the shafts and coupling.

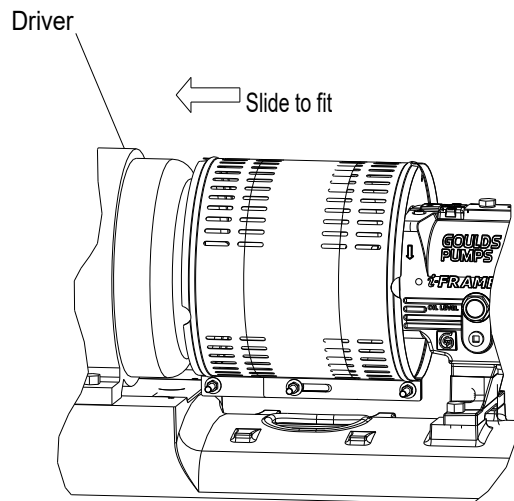

Figure 42: Slide driver-half of coupling guard towards motor

11. Repeat Steps 4 through 6 for the center slots in the coupling guard.
12. Tighten all nuts on the guard assembly.

5.10 Bearing lubrication



WARNING:

Risk of explosive hazard and premature failure from sparks and heat generation. Ensure bearings are properly lubricated prior to startup.

NOTICE:

Grease can settle in equipment left idle leaving bearings improperly lubricated. Check the greasing on a pump that has been out of service for a long period of time and re-grease if necessary.

5.10.1 Lubricate the bearings with oil



WARNING:



Risk of explosive hazard and premature failure from sparks and heat generation. Ensure bearings are properly lubricated prior to startup.

1. Remove the oil fill pipe plug (319B).
2. Fill the bearing frame with oil through the filler connection that is located on the top of the bearing frame.
3. Fill the bearing frame with oil until the oil level reaches the middle of the sight glass or opposite sight glass (319 or 408N). The correct volume of oil required for each size of bearing frame can be found in the 'Oil Volume Requirements' section in the 'Bearing Maintenance' / 'Maintenance' portion of the IOM.

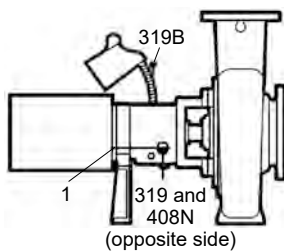

1. Correct level

Figure 43: Oil lubricated bearings

4. Replace the oil fill pipe plug (319B).

5.11 Shaft-sealing options

In most cases, the manufacturer seals the shaft before shipping the pump. If your pump does not have a sealed shaft, see the Shaft-seal maintenance section in the Maintenance chapter.



WARNING:

- The mechanical seal used in an Ex classified environment must be properly certified.

- The mechanical seal must have an appropriate seal-flush system. Failure to do so will result in excess heat generation and seal failure.

This model uses these types of shaft seals:

- Cartridge mechanical seal
- Packed-stuffing-box option

5.11.1 Mechanical seal options

Pumps are usually shipped with mechanical seals installed. If they are not, then refer to the mechanical seal manufacturer's installation instructions.

These are the mechanical seal options for this pump:

- Cartridge mechanical seal

5.11.2 Connection of sealing liquid for mechanical seals

Seal lubrication is required

Seal faces must have liquid film between them for proper lubrication. Locate the taps using the illustrations shipped with the seal.

If a flushless slurry seal was ordered, then consult manufacturers instructions for seal lubrication.

Seal flushing methods

Table 12: You can use these methods in order to flush or cool the seal:

Method	Description
Product flush	Run the piping so that the pump pushes the pumped fluid from the casing and injects it into the seal gland. If necessary, an external heat exchanger cools the pumped fluid before it enters the seal gland.
External flush	Run the piping so that the pump injects a clean, cool, compatible liquid directly into the seal gland. The pressure of the flushing liquid must be 0.35 to 1.01 kg/cm ² 5 to 15 psi greater than the seal chamber pressure. The injection rate must be 2 to 8 lpm 0.5 to 2 gpm.
Other	You can use other methods that employ multiple gland or seal chamber connections. Refer to the mechanical seal reference drawing and seal flush/cooling piping diagrams.

5.11.3 Packed stuffing box option



WARNING:

Packed stuffing boxes are not allowed in an Ex-classified environment.

The factory does not install the packing, lantern ring, or split gland.

These parts are included with the pump in the box of fittings. Before you start the pump, you must install the packing, lantern ring, and split gland according to the Packed stuffing box maintenance section in the Maintenance chapter.

5.11.4 Connection of sealing liquid for a packed stuffing box



WARNING:



The mechanical seal must have an appropriate seal-flush system. Failure to do so will result in excess heat generation and seal failure.

NOTICE:

Make sure to lubricate the packing. Failure to do so may result in shortening the life of the packing and the pump.

You must use an external sealing liquid under these conditions:

- The pumped fluid includes abrasive particles.
- The stuffing-box pressure is below atmospheric pressure when the pump is running with a suction lift or when the suction source is in a vacuum. Under these conditions, packing is not cooled and lubricated and air is drawn into pump.

Conditions for application of an external liquid

Condition	Action
The stuffing box pressure is above atmospheric pressure and the pumped fluid is clean.	Normal gland leaks of 40 to 60 drops per minute is usually sufficient to lubricate and cool the packing. You do not need sealing liquid.
The stuffing box pressure is below atmospheric pressure or the pumped fluid is not clean.	An outside source of clean compatible liquid is required.
An outside source of clean compatible liquid is required.	You must connect the piping to the lantern ring connection with a 40 to 60 drops-per-minute leak rate. The pressure must be 1.01 kg/cm ² 15 psi above the stuffing box pressure.

5.11.5 Seal the shaft with a packed stuffing box



WARNING:

- Packed stuffing boxes are not allowed in an Ex-classified environment.
- Dynamic seals are not allowed in an Ex-classified environment.



WARNING:

Failure to disconnect and lock out driver power may result in serious physical injury. Never attempt to replace the packing until the driver is properly locked out.

Pumps are shipped without the packing, lantern ring, or split gland installed. These parts are included with the box of fittings shipped with each pump and must be installed before startup.

1. Carefully clean the stuffing-box bore.
2. Twist the packing enough to get it around the shaft.

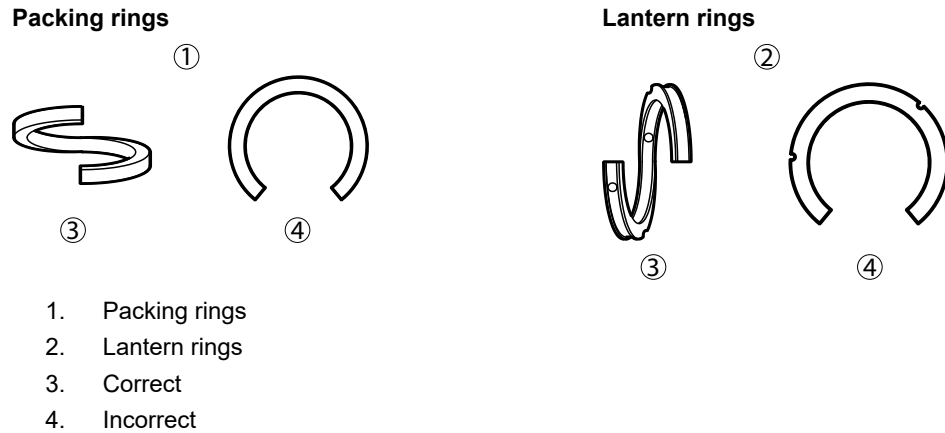
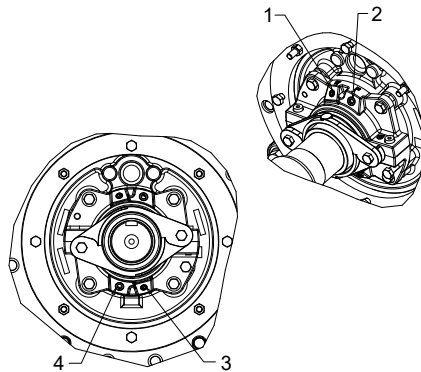

Figure 44: Packing rings and lantern rings

The XHD stuffing box is supplied with water connections for both the weep type and full flush configurations. The stuffing box cover is marked with an "F" and a "W" to show the proper locations for full flush or weep style connections.



1. Water flush (weep flush)
2. Water flush (full flush)
3. Water drain (weep flush)
4. Water drain (full flush)

Figure 45: Stuffing box water connections

Make sure that the stuffing box and shaft sleeve are clean before packing a pump. Also verify that the lantern ring is properly positioned to accept the flush water as shown.

3. Insert the packing and stagger the joints in each ring by 90°. Install the stuffing box parts in this order:
For weep flush setting **(2L3)**:
 - a) Two packing rings (106)
 - b) One lantern ring (105)
 - c) Three packing rings (106)

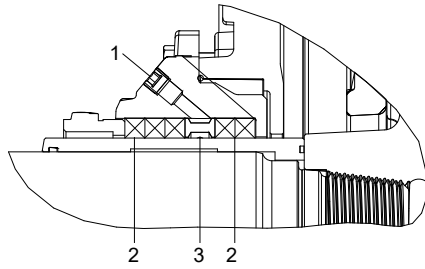

- i. Flush connection
- ii. Packing rings
- iii. Lantern ring

Figure 46: Weep flush setting (2L3)

For full flush setting (L5):

- a) One lantern ring (105)
- b) Five packing rings (106)

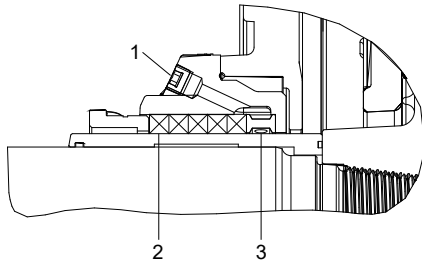

- i. Flush connection
- ii. Packing rings
- iii. Lantern ring

Figure 47: Full flush setting (L5)

For full flush setting (1L4):

- a) One packing ring (106)
- b) One lantern ring (105)
- c) Four packing rings (106)

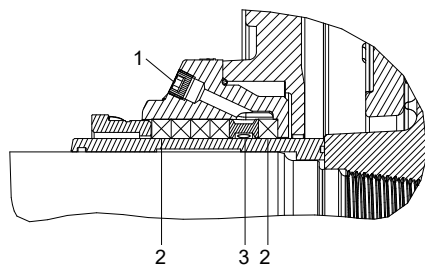

- i. Flush connection
- ii. Packing rings
- iii. Lantern ring

Figure 48: Full flush setting (1L4)

4. Install the gland halves and evenly hand-tighten the nuts .

NOTICE:

Do not overtighten gland nuts. Overtightened packing causes excessive friction between packing and sleeve and will result in damaged components.

Table 13: Flush water requirements

The flush water requirements are listed for both the weep style and full flush packing arrangements.

Group	Size	(L5) Full Flush liters/min GPM	Full Flush (1L4) liters/min GPM	(2L3) Weep Flush liters/min GPM	Mechanical Seal Flush
PF1	XHD50,75	38 10	26 6	0.8 0.2	Consult Seal Mfg
PF2	XHD80	57 15	38 10	1.1 0.3	
PF3	XHD125	87 23	68 18	2.3 0.6	
PF4, PF4S	XHD150,200	140 37	121 32	4.2 1.1	
PF5	XHD250,300	231 61	212 56	8.3 2.2	

5.12 Install the shaft guard - if provided

**WARNING:**

- Running a pump without safety devices exposes operators to risk of serious personal injury or death. Never operate a unit unless appropriate safety devices (guards, etc.) are properly installed.
- Failure to disconnect and lock out driver power may result in serious physical injury or death. Always disconnect and lock out power to the driver before performing any installation or maintenance tasks.
 - Electrical connections must be made by certified electricians in compliance with all international, national, state, and local rules.
- Exposed rotating shaft between pump seal and bearing frame. Avoid contact and/or install proper guarding. If guarding is not provided with the pump, contact Goulds for price and availability of proper guarding.

5.13 Pump priming

**WARNING:**

These pumps are not self priming and must be fully primed at all times during operation. Loss of prime can lead to excessive heat and severe damage to the pump and seal.

**WARNING:**

Pumps that are not self-priming must be fully primed at all times during operation.

**WARNING:**

A build-up of gases within the pump, sealing system, or process piping system may result in an explosive environment. Make sure the process piping system, pump and sealing system are properly vented prior to operation.

5.13.1 Prime the pump with the suction supply above the pump

1. Slowly open the suction isolation valve.
2. Open the air vents on the suction and discharge piping until the pumped fluid flows out.
3. Close the air vents.

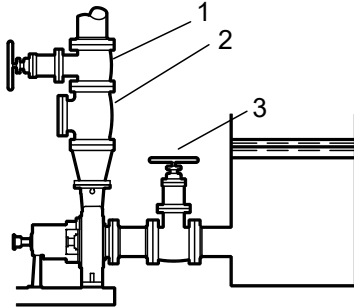

Item	Description
1.	Discharge isolation valve
2.	Check valve
3.	Suction isolation valve

Figure 49: Suction supply above pump

5.13.2 Prime the pump with the suction supply below the pump

Use a foot valve and an outside source of liquid in order to prime the pump. The liquid can come from one of these sources:

- A priming pump
 - A pressurized discharge line
 - Another outside supply
1. Close the discharge isolation valve.
 2. Open the air vent valves in the casing.
 3. Open the valve in the outside supply line until only liquid escapes from the vent valves.
 4. Close the vent valves.
 5. Close the outside supply line.

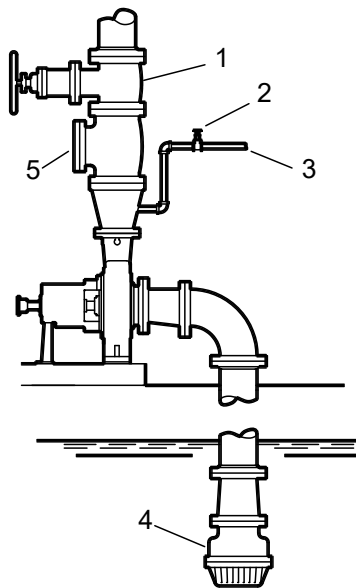

Item	Description
1.	Discharge isolation valve
2.	Shutoff valve
3.	From outside supply
4.	Foot valve
5.	Check valve

Figure 50: Pump priming with suction supply below pump with foot valve and an outside supply

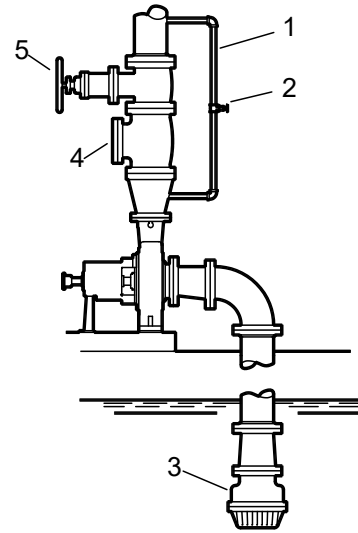

Item	Description
1.	By-pass line
2.	Shutoff valve
3.	Foot valve
4.	Check valve
5.	Discharge isolation valve

Figure 51: Pump priming with suction supply below pump with foot valve using bypass around check valve

5.13.3 Other methods of priming the pump

You can also use these methods in order to prime the pump:

- Prime by ejector
- Prime by automatic priming pump

5.14 Start the pump



WARNING:

- Risk of equipment damage, seal failure and breach of containment. Ensure all flush and cooling systems are operating correctly prior to starting pump.
-

NOTICE:

- Risk of equipment damage due to dry operation. Immediately observe the pressure gauges. If discharge pressure is not quickly attained, stop the driver immediately, reprime, and attempt to restart the pump.

- On frame mounted units, ensure that the oil level is correct prior to starting pump. Close coupled pumps do not have oil lubricated bearings.
-
-

NOTICE:

Risk of equipment damage on pure or purge-oil mist-lubricated units. Remove the viewing port plugs to verify that oil mist is flowing properly. Reinstall the plugs after confirming.

Before you start the pump, you must perform these tasks:

- Open the suction valve.
 - Open any recirculation or cooling lines.
1. Fully close or partially open the discharge valve, depending on system conditions.
 2. Start the driver.
 3. Slowly open the discharge valve until the pump reaches the desired flow.
 4. Immediately check the pressure gauge to ensure that the pump quickly reaches the correct discharge pressure.
 5. If the pump fails to reach the correct pressure, perform these steps:
 - a) Stop the driver.
 - b) Prime the pump again.
 - c) Restart the driver.
 6. Monitor the pump while it is operating:
 - a) Check the pump for bearing temperature, excessive vibration, and noise.
 - b) If the pump exceeds normal levels, then shut down the pump immediately and correct the problem.

A pump can exceed normal levels for several reasons. See Troubleshooting for information about possible solutions to this problem.

5.15 i-ALERT® Equipment Health Monitor



WARNING:

Explosive hazard and risk of personal injury. Heating to high temperatures could cause combustion of the condition monitor. Never heat the condition monitor to temperatures in excess of 149°C | 300°F or dispose of in a fire.

For all information refer to the i-ALERT® Equipment Health Monitor Installation, Operation and Maintenance manual. <https://www.i-alert.com/support/>

5.16 Pump operation precautions

General considerations



WARNING:

- Risk of serious personal injury or property damage. Dry running may cause rotating parts within the pump to seize to non-moving parts. Do not run dry.
 - Risk of explosion and serious physical injury. Do not operate pump with blocked system piping or with suction or discharge valves closed. This can result in rapid heating and vaporization of pumpage.
-

NOTICE:

- Vary the capacity with the regulating valve in the discharge line. Never throttle the flow from the suction side. This action can result in decreased performance, unexpected heat generation, and equipment damage.
- Risk of equipment damage from unexpected heat generation. Do not overload the driver. Ensure that the pump operating conditions are suitable for the driver. The driver can overload in these circumstances:
 - The specific gravity or viscosity of the fluid is greater than expected
 - The pumped fluid exceeds the rated flow rate.
- Do not operate pump past maximum flow. For maximum flow refer to pump performance curve.
- Do not operate pump below hydraulic or thermal minimum flow. For hydraulic minimum flows refer to technical manual and pump performance curves. To calculate thermal minimum flow, refer to HI Centrifugal Pump Design and Application ANSI/HI 1.3-2000.

Operation at reduced capacity**WARNING:**

- Risk of breach of containment and equipment damage. Excessive vibration levels can cause damage to bearings, stuffing box, seal chamber, and/or mechanical seal. Observe pump for vibration levels, bearing temperature, and excessive noise. If normal levels are exceeded, shut down and resolve.
- Risk of explosion and serious physical injury. Do not operate pump with blocked system piping or with suction or discharge valves closed. This can result in rapid heating and vaporization of pumpage.
- Risk of equipment damage and serious physical injury. Heat build-up can cause rotating parts to score or seize. Observe pump for excessive heat build-up. If normal levels are exceeded, shut down and resolve.

**CAUTION:**

- The pump and system must be free of foreign objects. If pump becomes plugged, shut down and unplug prior to restarting the pump.
- Avoid increased radial load. Failure to do so can cause stress on the shaft and bearings.

NOTICE:

- Cavitation can cause damage to the internal surfaces of the pump. Ensure net positive suction head available ($NPSH_A$) always exceeds $NPSH$ required ($NPSH_R$) as shown on the published performance curve of the pump.
-

Operation under freezing conditions**NOTICE:**

Do not expose an idle pump to freezing conditions. Drain all liquid that will freeze that is inside the pump and any auxiliary equipment. Failure to do so can cause liquid to freeze and damage

the pump. Note that different liquids freeze at different temperatures. Some pump designs do not drain completely and may require flushing with a liquid that doesn't freeze.

5.17 Shut down the pump



WARNING:

Precautions must be taken to prevent physical injury. The pump may handle hazardous and/or toxic fluids. Proper personal protective equipment should be worn. Pumpage must be handled and disposed of in conformance with applicable environmental regulations.

1. Slowly close the discharge valve.
2. Shut down and lock out the driver to prevent accidental rotation.

5.18 Deactivate the i-ALERT® Equipment Health Monitor

NOTICE:

Always deactivate the health monitor when the pump is going to be shut down for an extended period of time. Failure to do so will result in reduced battery life.

Disengage the snap fit of the i-ALERT® using a flat head tool as shown below:



Figure 52: Disengage the battery from the sensor when shutting the pump for an extended period of time

5.19 Reset the i-ALERT® Health Monitor

To deactivate or reset the i-ALERT® monitor, please refer to the i-ALERT® IOM, <http://i-alert.com/>

Always reset the health monitor when the pump is started after maintenance, system change, or being shut down for an extended period of time. Failure to do so may result in false baseline levels that could cause the health monitor to alert in error.

5.20 Make the final alignment of the pump and driver

**WARNING:**

- Failure to disconnect and lock out driver power may result in serious physical injury or death. Always disconnect and lock out power to the driver before performing any installation or maintenance tasks.
 - Electrical connections must be made by certified electricians in compliance with all international, national, state, and local rules.
 - Refer to driver/coupling/gear manufacturer's installation and operation manuals (IOM) for specific instructions and recommendations.
- Misalignment can cause decreased performance, equipment damage, and even catastrophic failure of frame-mounted units leading to serious injury. Proper alignment is the responsibility of the installer and the user of the unit. Check the alignment of all drive components prior to operating the unit.
 - Follow the coupling installation and operation procedures from the coupling manufacturer.

You must check the final alignment after the pump and driver are at operating temperature. For initial alignment instructions, see the Installation chapter.

1. Run the unit under actual operating conditions for enough time to bring the pump, driver, and associated system to operating temperature.
2. Shut down the pump and the driver.
3. Remove the coupling guard or v-belt drive.
See Remove the coupling guard or Remove the v-belt drive guard section in this chapter.
4. Check the alignment while the unit is still hot.
Refer to [4.5 Pump-to-driver alignment on page 33](#) for either coupled or v-belt driven unit in the Installation chapter.
5. Reinstall the coupling guard or v-belt drive.
6. Restart the pump and driver.

6 Maintenance

6.1 Maintenance schedule

NOTICE:

The preventive maintenance section must be adhered to in order to keep the applicable Ex classification of the equipment. Failure to follow these procedures will void the Ex classification for the equipment.

Maintenance inspections

A maintenance schedule includes these types of inspections:

- Routine maintenance
- Routine inspections
- Three-month inspections
- Annual inspections

Shorten the inspection intervals appropriately if the pumped fluid is abrasive or corrosive or if the environment is classified as potentially explosive.

Routine maintenance

Perform these tasks whenever you perform routine maintenance:



WARNING:

Move equipment to a safe/non Ex environment for repairs/adjustments or use spark resistant tools and work methods.

- Lubricate the bearings.
- Inspect the seal.

Routine inspections

Perform these tasks whenever you check the pump during routine inspections:



WARNING:

Move equipment to a safe/non Ex environment for repairs/adjustments or use spark resistant tools and work methods.

- Check the level and condition of the oil through the sight glass on the bearing frame.
- Check for unusual noise vibration, and bearing temperatures.
- Check the pump and piping for leaks.
- Analyze the vibration.*
- Inspect the discharge pressure.
- Inspect the temperature.*
- Check the seal chamber and stuffing box for leaks.

- Ensure that there are no leaks from the mechanical seal.
- Adjust or replace the packing in the stuffing box if you notice excessive leaking.

Three-month inspections

Perform these tasks every three months:

- Check that the foundation and the hold-down bolts are tight.
- Check the packing if the pump has been left idle, and replace as required.
- Change the oil every three months (2000 operating hours) at minimum.
- Check the shaft alignment, and realign as required.

Annual inspections

Perform these inspections one time each year:

- Check the pump capacity.
- Check the pump pressure.
- Check the pump power.

If the pump performance does not satisfy your process requirements, and the process requirements have not changed, then perform these steps:

1. Disassemble the pump.
2. Inspect it.
3. Replace worn parts.

6.1.1 Bearing maintenance



These bearing lubrication sections list different temperatures of the pumped fluid. If the pump is Ex-certified and the temperature of the pumped fluid exceeds the permitted temperature values, then consult your ITT representative.



For Ex applications bearing replacement (all) is recommended after 17,500 hours of operation.

Bearing lubrication schedule

Type of bearing	First lubrication	Lubrication intervals
Oil-lubricated bearings	Add oil before you install and start the pump. Change the oil after 200 hours for new bearings.	After the first 200 hours, change the oil every 1000 operating hours or every two months.
Grease-lubricated bearings	Grease-lubricated bearings are initially lubricated at the factory.	Regrease bearings every 500 operating hours or every month.

6.1.2 Lubricating oil requirements

Use a high quality turbine oil with rust and oxidation inhibitors.

You can use an oil of ISO viscosity grade VG 220 (SAE grade 50W) for all bearing operation temperature ranges.

6.1.3 Oil volumes

Oil volume requirements

Frame	Milliliters	Quarts	Ounces
PF1	1040	1.1	35
PF2	1400	1.5	48
PF3	1600	1.7	54
PF4S	2630	2.78	89
PF4	3975	4.2	134
PF5	4600	4.9	157

6.1.4 Acceptable oil for lubricating bearings

Acceptable lubricants

Use a high quality turbine oil with rust and oxidation inhibitors.

Oil ISO viscosity recommendations can vary based on Operating speed, Ambient temperature and Rotating element loading.

The following recommendations for oil viscosity will suit a variety of XHD product applications. Due to variables during operation such as operational speed, SG of liquid being pumped, ambient temperature, bearing setting preload and other factors, the tapered roller bearings used on XHD products can routinely operate at temperatures as high as 99°C | 210°F. As a general rule, oil temperature above 102°C | 215°F should be avoided, except during initial break in of new equipment. In no case should bearings ever operated above 121°C | 250°F for any period of time.

In the event of excessive bearing temperatures as defined above, monitor bearing and oil temperature to confirm then investigate the root cause. Bearing preload, and improper assembly are possible causes. Confirm bearing preload (End cover shimming) for correct assembly per the procedure outlined in the assembly section of this IOM. Based on Ambient temperature, operating speed, and application variables (SG / temp) a different oil viscosity may be selected for the application.

Table 14: Frame Designation Oil Viscosity (General Recommendation)

Frame Designation	Oil Viscosity
PF1	100
PF2	100
PF3	100
PF4 / PF4S	150
PF5	220

Table 15:

Brand	Lubricant Type		
	Castrol	Hyspin R&O 220	Hyspin R&O 150
Chevron	GST 220	GST ISO 150	GST ISO 100
Exxon	Teresstic 220	Teresstic 150	Teresstic 100
Mobil	DTE Oil BB	- - -	VG100
	Gear 630	Gear 150	Gear 627
Shell	Morlina 220	Morlina 150	Morlina 100
	Tellus 220	- - -	Tellus 100
Sunoco	Sunvis 9220	Sunvis 9150	Sunvis 9100

Brand	Lubricant Type		
Texaco	Regal R&O 220	Regal R&O 150	Regal R&O 100
	Rando HD 220	Rando HD 150	Rando HD 100
Royal Purple	Synfilm GT 220	Synfilm GT 150	Synfilm GT 100
	Synergy 220	Synergy 150	Synergy 100

6.1.5 Lubricating-grease requirements

Precautions

NOTICE:

- Avoid equipment damage or decreased performance. Never mix greases of different consistencies (NLGI 1 or 3 with NLGI 2) or with different thickeners. For example, never mix a lithium-based grease with a polyurea based grease. If it is necessary to change the grease type or consistency, remove the rotor and old grease from the housing before re-greasing.

Grease recommendations

Use a lithium-based mineral-oil grease with a consistency of NLGI 2 with EP additives.

This table shows which brand and type of grease to use when lubricating the pump.

Brand	Grease type
Castrol	Castrol EPL2
Exxon	Unirex EP2
Lubriplate	SYN 1602
Mobil	Mobilux EP 2
	Mobilux EP460
Shell	Alvania EP2
SKF	LGEP2
	LGWA 2
Texaco	Multifak EP 2

Grease amounts

Size	Initial grease in grams ounces per bearing	Regrease amount in grams ounces per bearing
PF1 Outboard	62 2.2	17 0.6
PF1 Inboard	48 1.7	
PF2 Outboard	107 3.8	28 1.0
PF2 Inboard	74 2.6	
PF3 Outboard	298 10.5	45 1.6
PF3 Inboard	175 6.2	
PF4S Outboard	340 12	45 1.6
PF4S Inboard	212 7.5	
PF4 Outboard	1378 48.6	88 3.1
PF4 Inboard	1108 39.1	
PF5 Outboard	1408 49.7	122 4.3
PF5 Inboard	1408 49.7	

6.1.5.1 Regrease the grease-lubricated bearings

NOTICE:

Risk of equipment damage. Ensure that the grease container, the greasing device, and the fittings are clean. Failure to do so can result in impurities entering the bearing housing while regreasing the bearings.

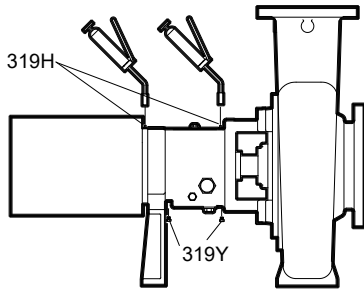

Figure 53: Grease-lubricated bearings

1. Wipe dirt from the grease fittings(319H).
2. Fill both of the grease cavities through the fittings with a recommended grease until the fresh grease comes out of the relief fittings (319Y).
3. Make sure that the grease retention rings (253) are seated in the bearing housing. If they are not, press them in place with the drains located at the bottom.
4. Wipe off any excess grease.
5. Recheck the alignment.

The bearing temperature usually rises after you regrease due to an excess supply of grease. Temperatures return to normal in about two to four operating hours as the pump runs and purges the excess grease from the bearings.

6.1.5.2 Lubricate the bearings after a shutdown period

1. Flush out the bearings and bearing frame with a light oil to remove contaminants. During flushing, make sure to rotate the shaft slowly by hand.
2. Flush the bearing housing with the proper lubricating oil to ensure oil quality after cleaning.
3. Refer to *Reassembly* section for proper bearing greasing procedure.

6.1.6 Shaft-seal maintenance

6.1.6.1 Mechanical-seal maintenance



WARNING:

- The mechanical seal used in an Ex-classified environment must be properly certified.
-



WARNING:

The mechanical seal used in an Ex classified environment must be properly certified.

**CAUTION:**

Running a mechanical seal dry, even for a few seconds, can cause seal failure and physical injury. Never operate the pump without liquid supplied to the mechanical seal.

Cartridge-type mechanical seals

Cartridge-type mechanical seals are commonly used. Cartridge seals are preset by the seal manufacturer and require no field settings. Cartridge seals installed by the user require disengagement of the holding clips prior to operation, allowing the seal to slide into place. If the seal has been installed in the pump by ITT, these clips have already been disengaged.

Other mechanical seal types

For other types of mechanical seals, refer to the instructions provided by the seal manufacturer for installation and setting.

Reference drawing

The manufacturer supplies a reference drawing with the data package. Keep this drawing for future use when you perform maintenance and seal adjustments. The seal drawing specifies the required flush fluid and attachment points.

Before you start the pump

Check the seal and all flush piping.

Mechanical seal life

The life of a mechanical seal depends on the cleanliness of the pumped fluid. Due to the diversity of operating conditions, it is not possible to give definite indications as to the life of a mechanical seal.

6.1.6.2 Packed stuffing-box maintenance**WARNING:**

Packed stuffing boxes are not allowed in an Ex-classified environment.

**WARNING:**

Failure to disconnect and lock out driver power may result in serious physical injury. Never attempt to replace the packing until the driver is properly locked out.

Accepted leakage rate

It is not necessary to shut down or disassemble the pump to inspect the packing operation. During normal operation, the packing should leak approximately one drop per second.

Adjustment of gland

Adjust the gland if the leakage rate is greater than or less than the specified rate.

Evenly adjust each of the two gland bolts with a one-quarter (1/4) turn until the desired leakage rate is obtained. Tighten the bolts to decrease the rate. Loosen the bolts to increase the rate.

Tightening of packing

NOTICE:

Never over-tighten packing to the point where less than one drop per second is observed. Over-tightening can cause excessive wear and power consumption during operation.

If you cannot tighten the packing to obtain less than the specified leakage rate, then replace the packing.

6.1.6.3 Dynamic seal maintenance

Precautions



WARNING:

- Packed stuffing boxes are not allowed in an Ex-classified environment.
 - Dynamic seals are not allowed in an Ex-classified environment.
-

Dynamic seal parts

Dynamic seal parts normally do not wear enough to affect operation unless the service is particularly abrasive. The dynamic seal consists of two parts:

- The expeller seal prevents leakage during operation.
- The secondary seal prevents or minimizes leakage during shutdown of the unit.
 - Graphite packing, provides adequate life when it runs dry but can provide longer performance if it is lubricated with clean water (Flush) or grease via a spring loaded grease cup.

Expeller seal maintenance

Some services might require a flush if solids have built up on the expeller. The unit contains a flush tap for that purpose.

Graphite packing maintenance

Graphite packing requires the same maintenance as any other packing. When adjustments can no longer be made with the gland because it contacts the box face, perform these maintenance tasks:

- Shut down the pump.
- Relieve the pressure.
- Add another ring of packing to the box.

If the lantern ring connection is used but no longer lines up with the flush port, you need to clean and repack the stuffing box. The repacking procedure is the same as the procedure outlined in the Commissioning, Startup, Operation, and Shutdown chapter except this is the arrangement:

- One ring of packing
- The lantern ring
- Two rings of packing

Acceptable leaks

Slight leaks can be considered normal, but excessive dripping or spray indicates a problem.

Stuffing box cover

The stuffing box cover used with the dynamic seal option is equipped with two lantern ring connections:

- One expeller flush connection
- One expeller drain connection

The lantern ring connection can be used to inject flush liquid or grease when required on specific applications.

Drain tap

The drain tap allows you to drain the liquid that remains in the expeller chamber upon pump shutdown. Consider removing this liquid before you service the pump in order to prevent it from hardening, or protect the pump during freezing weather. The flush tap allows injection of water or steam directly into the repeller chamber near the base of the repeller vanes.

Injected liquid

Injected liquid can be used in conjunction with the drain in order to flush the chamber of solids or potentially harmful liquids.

6.2 Disassembly

6.2.1 Disassembly precautions



WARNING:

- Failure to disconnect and lock out driver power may result in serious physical injury or death. Always disconnect and lock out power to the driver before performing any installation or maintenance tasks.
 - Electrical connections must be made by certified electricians in compliance with all international, national, state, and local rules.
 - Refer to driver/coupling/gear manufacturer's installation and operation manuals (IOM) for specific instructions and recommendations.
- Risk of serious personal injury. Applying heat to impellers, propellers, or their retaining devices can cause trapped liquid to rapidly expand and result in a violent explosion. This manual clearly identifies accepted methods for disassembling units. These methods must be adhered to. Never apply heat to aid in their removal unless explicitly stated in this manual.
- Handling heavy equipment poses a crush hazard. Use caution during handling and wear appropriate Personal Protective Equipment (PPE, such as steel-toed shoes, gloves, etc.) at all times.
- Precautions must be taken to prevent physical injury. The pump may handle hazardous and/or toxic fluids. Proper personal protective equipment should be worn. Pumpage must be handled and disposed of in conformance with applicable environmental regulations.
- Risk of serious physical injury or death from rapid depressurization. Ensure pump is isolated from system and pressure is relieved before disassembling pump, removing plugs, opening vent or drain valves, or disconnecting piping.
- Risk of serious personal injury from exposure to hazardous or toxic liquids. A small amount of liquid will be present in certain areas like the seal chamber upon disassembly.

**CAUTION:**

- Avoid injury. Worn pump components can have sharp edges. Wear appropriate gloves while handling these parts.
-

6.2.2 Wet end disassembly instructions

Follow these precautions before disassembly:

- Remove the v-belt or coupling guard.
- For pumps that are coupled to the motor, uninstall the coupling.
- On a pump that is v-belt driven, the overhead mount or side-by-side slide base must be adjusted to loosen the belts.
- De-energize, lock-out, and tag-out the motor.
- Check to ensure that the pedestal frame is securely fastened to the foundation, base plate, or work surface, such as a workbench.

6.2.3 Tools required

In order to disassemble the pump, you need these tools:

- Allen wrenches
- Metric stud drivers
- Cleaning agents and solvents
- Chisel
- Dial indicators
- Hoist and strap
- Pry bars
- Sockets
- Soft face hammer
- Spanner wrench
- Torque wrench
- Wrenches
- Lifting eyebolt (dependent on pump / motor size)

6.2.4 Disassembly for Metal-Lined

The disassembly steps for Metal-lined and Rubber-lined differ. This section, beginning with *Typical disassembly* and ending with *Remove the shaft sleeve*, pertains to Metal-lined pumps.

For Rubber-lined pumps, refer to the sub-section, [6.2.8 Disassembly for Rubber-Lined on page 97](#).

6.2.5 Typical disassembly - Metal-Lined

The XHD slurry pump is available in two models: the basic version, referred to as XHD and the XHD Value Option. The method of disassembly and assembly can vary between these models. The XHD is a front pull out design. Typical disassembly steps can be followed for both the XHD and XHD Value Option.

The suction half casing and attached components can be removed for further disassembly and replacement of the suction side liner (562) and adjustable seal ring (822, XHD only) as necessary. After removing the impeller (101) by disengaging the knock-off ring (149), the gland half casing (100D) can remain mounted to the pedestal (131) and the casing volute liner (561) removed for replacement. Other components such as the gland, packing, seal cover etc. can also be removed in a methodical fashion as needed for inspection and replacement. In addition to traditional sequential disassembly methods, the entire

wet end can be completely removed from the pedestal and bearing frame on the XHD model, as outlined in the following section: XHD Complete Wet End Disconnection.

6.2.6 Complete wet end disconnection - XHD only

The XHD model features a "quick disconnect" wet end option. Removal of the entire wet end from the bearing frame and pedestal can be performed as follows:

1. Loosen the two forward adjusting nuts rod nuts (415A) on both sides of the power frame by turning them clockwise.
2. Loosen the hold-down bolts (352G) that clamp the adjustment plates (234F) to the bearing cartridge housing (228) but do NOT remove. Bolts should remain finger-tightened to keep the bearing frame constrained to the pedestal while allowing it to slide along the pedestal rails.
3. Turn the two rearward adjusting nuts (415A) on both sides of the power frame sequentially clockwise, 1/3 turn of each nut at a time, to draw the bearing frame and impeller (101) toward the casing volute liner (561). Stop when the impeller is firmly seated against the volute liner.
4. Loosen the three adjustable seal ring jam nuts (357A) by turning them clockwise.
5. Turn the seal ring square head adjusting bolts (356F) sequentially, counterclockwise 1/3 of a turn at a time, to move the adjustable seal ring forward in the casing until it is firmly seated against the impeller.
6. Lock the seal ring adjusting bolts (356F) in place by re-tightening the jam nuts (357A) against the suction half casing (100A).
7. Remove the 2 piece Knockoff ring and bolts (149) to remove the tension on the impeller threads, then turn the shaft (122) counterclockwise to disengage the shaft threads from the impeller. This will cause the bearing frame to move rearward on the pedestal until the shaft disengages from the impeller (101) held captive in the casing by the adjustable seal ring. NOTE: This should take 4 - 5 complete shaft turns.
8. Attach hoist hook to the gland half casing (100D) lifting lug and tension to support. Do not over-tension the hoist. Over-tensioning and lifting up on the wet end assembly with the hoist could cause shaft and bearing frame component damage.
9. Remove the tapered alignment stud hex nuts (427L) that attach the gland half casing (100D) to the pedestal (131).
10. Remove the hex head cap screws (370Y) that attach the gland half casing (100D) to the pedestal (131).
11. Remove the entire wet end from the pedestal and power end. The wet end will need to be moved forward horizontally enough to clear the end of the shaft before the wet end is lifted or lowered using the hoist. While moving the wet end forward, keep the entire assembly level and concentric with the shaft.

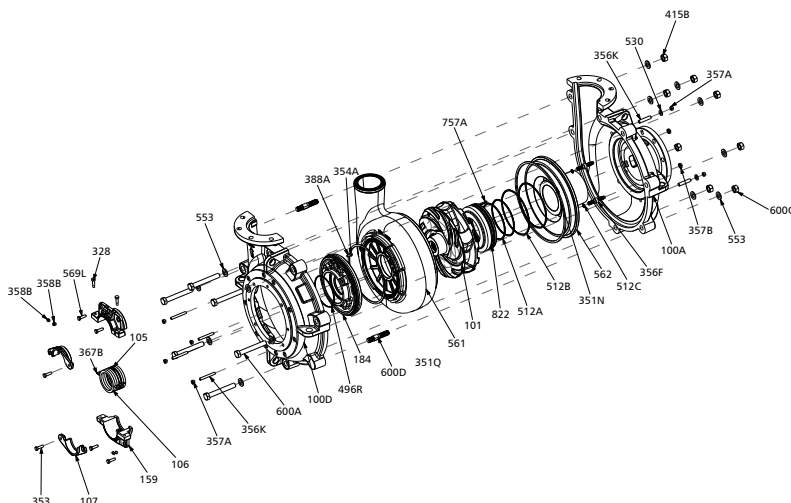

Figure 54: Wet end exploded view, Metal lined

6.2.7 Wet end disassembly instructions

Follow these precautions before disassembly:

- Remove the v-belt or coupling guard.
- For pumps that are coupled to the motor, uninstall the coupling.
- On a pump that is v-belt driven, the overhead mount or side-by-side slide base must be adjusted to loosen the belts.
- De-energize, lock-out, and tag-out the motor.
- Check to ensure that the pedestal frame is securely fastened to the foundation, base plate, or work surface, such as a workbench.

6.2.7.1 Remove the joint gaskets and flanges - Metal-Lined

1. Remove the discharge joint flat gasket (351A).
2. Remove the suction flat gasket (351B).
3. Remove the two-piece suction and discharge flanges (195C, XHD sizes 150 and above only).

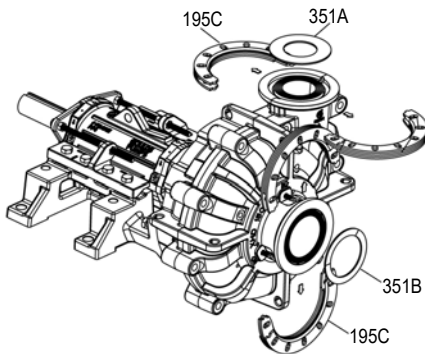

Figure 55: Removal of joint gaskets and flanges - metal lined

6.2.7.2 Remove the suction half casing - Metal-Lined

The following parts remain attached to the suction half casing when it is removed from the rest of the pump wet end:

Model	Parts that are still attached
XHD	<ul style="list-style-type: none"> • Suction side liner (562) • Adjustable seal ring (822) • Hardware Square head adjusting bolts (356F) and hex jam nuts (357A)
XHD Value Option	<ul style="list-style-type: none"> • Suction side liner (562) • Hardware Hex head bolts/hex cap screws

1. Support the suction half casing (100A) with a hoist hook through the lifting lug. Tension the hoist properly so the subassembly will be fully supported upon disengagement.
2. Remove the casing hex head nuts (600C) and flat washers (553) from the casing hex head bolts (600A) and tapered alignment studs (600D).
3. Leave the tapered alignment studs (600D) secured in place. The studs will provide guidance in removal of the subassembly.
4. Guide the suction half casing (100A, with attached components) free of tapered alignment studs.

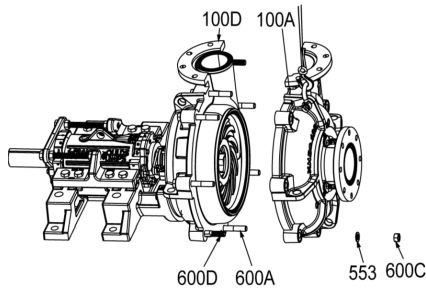

Figure 56: Removal of suction half casing - metal lined

5. Remove the hex head casing bolts (600A) from the gland half casing (100D).
6. Remove the tapered alignment studs (600D) from the gland half casing (100D) using a metric stud driver.

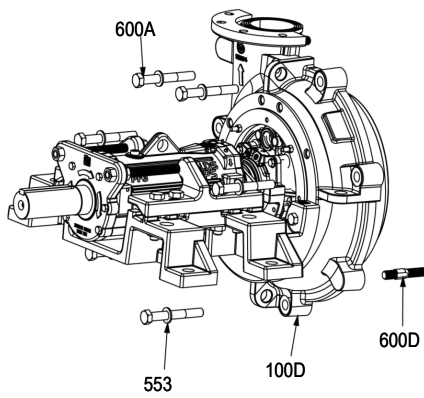

Figure 57: Casing bolt removal

6.2.7.3 Remove the remaining suction half components - Metal-Lined

Pump model	Next step to follow
XHD	<ul style="list-style-type: none"> • Remove the suction side liner and adjustable seal ring • Remove the adjustable seal ring
XHD Value Option	<ul style="list-style-type: none"> • Remove the suction liner

6.2.7.4 Remove suction side liner - XHD Value Option - Metal-Lined

1. Remove the suction side liner retention nuts (357A).
2. Remove suction side liner (562) from suction half casing (100A).
3. Remove the suction side liner retentions studs (356E) from the suction side liner (562) using a metric stud driver.
4. Remove the suction side liner flat gasket (351N).

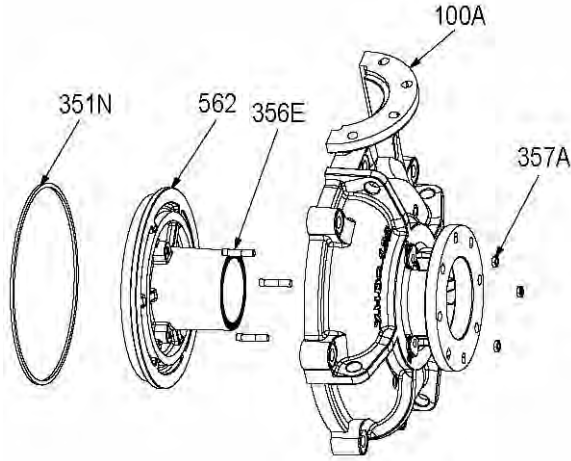

Figure 58: Removal of suction side liner - metal lined

6.2.7.5 Remove the suction side liner and adjustable seal ring - XHD - Metal-Lined

1. Remove the jam nuts (357A) that attach the adjustable seal ring (822) and the suction side liner (562) to the suction half casing (100A).
2. Remove the suction side liner holding bolts (372N, XHD sizes 150 and above only).
3. Move the suction side liner (562) with adjustable seal ring (822) inside free from the suction half casing (100A).
4. Remove the suction side liner front gasket (351N).

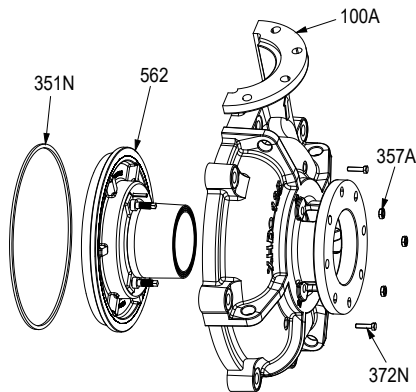

Figure 59: Removal of Suction liner (Metal Lined)

Suction side liner holding bolts on XHD sizes 150, 200, 250 and 300 only.

6.2.7.6 Remove the adjustable seal ring - XHD - Metal-Lined

1. Slide the adjustable seal ring (822) free from the suction side liner (562).
2. Remove the square head adjusting bolts (372N) from the adjustable seal ring.
3. Remove the seal ring inner diameter o-rings (512A) and outer diameter o-rings (512B). The indicating roll pin (757A) can also be removed if necessary.

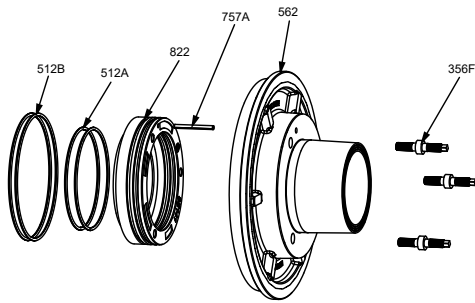

Figure 60: Removal of adjustable seal ring - metal lined

6.2.7.7 Impeller removal - Metal-Lined

Two people should work together to remove the impeller for safety purposes.

1. Remove the gland assembly halves (107) by removing the gland adjusting bolts (353).
2. Loosen the bearing frame adjustment plate bolts (352G) and nuts (427D) but DO NOT remove hardware or adjustment plates (234F). Keep hardware finger-tight to keep the bearing frame constrained to the pedestal while allowing it to slide along the pedestal rails.
3. Slide the bearing housing and shaft assembly forward towards the suction side of the pump to allow better access to the impeller (101).
4. Remove the two-piece knock-off ring (149).
5. Support the impeller (101) using a Goulds-provided impeller hook attached to the hoist. An overhead hoist chain or sling can also be routed through a vane passage to support the impeller.
6. With one person holding the impeller (101) in place, the other person rotates the shaft (122) counterclockwise to unscrew the impeller. This step should take 4 to 5 complete shaft turns.
7. Guide the impeller (101) completely free of the shaft threads and casing volute liner (561).

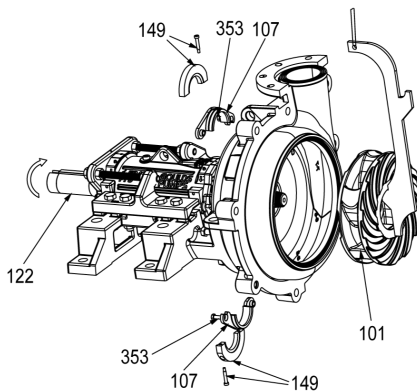

Figure 61: Impeller removal - metal lined

6.2.7.8 Stuffing box removal

Pump Model	Next step to follow
XHD	<ul style="list-style-type: none"> • The stuffing box is split and can be disassembled prior to casing volute liner removal. Continue with the Remove the split stuffing box step below.
XHD Value Option	<ul style="list-style-type: none"> • The stuffing box is integral to the seal cover. Skip to the Remove the seal cover step.

6.2.7.9 Remove the split stuffing box XHD

NOTICE:

This section applies only to units equipped with a split stuffing box. If your unit is not equipped with a split stuffing box, the seal cover /chamber will be removed at a later step.

1. Remove the shoulder bolts (328) that hold the two halves together.
2. Remove the hex head bolts (569L) that attach the split stuffing box (159) to the seal cover (184).
3. Remove the split stuffing box halves (159).
4. Remove the split stuffing box gaskets (367B).
5. Remove the packing (106) and lantern ring (105). The lantern ring has a split cut that can be widened to accommodate removal without permanently deforming the part.

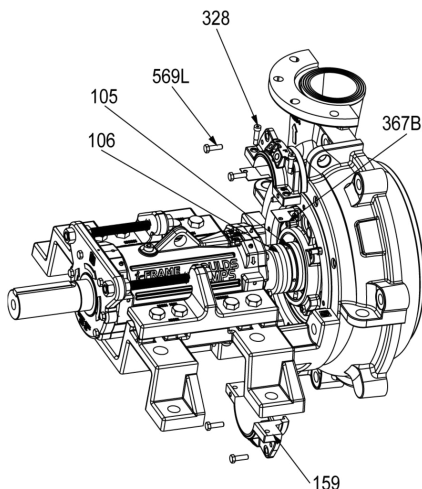

Figure 62: Removal of split stuffing box

6.2.7.10 Remove the casing volute liner - Metal-Lined

NOTICE:

The casing volute liner can be removed individually using the following steps if there is an expeller installed or if there is no expeller, then the gland casing, volute liner, and seal cover can be removed as one assembly, using the instructions from the section [6.2.7.13 Optional disassembly of gland half casing, volute liner, and seal cover - Metal-Lined on page 95](#)

1. Support the casing volute liner (561) with a Goulds-provided volute liner hook attached to the hoist. A sling can also be routed through and around the discharge opening of the casing volute liner for support for some discharge orientations.
2. Remove the casing volute liner retention nuts (357A) from the volute liner retention studs (356K) at the back of the gland half casing (100D).
3. Move the casing volute liner (561) out of and away from the gland half casing.

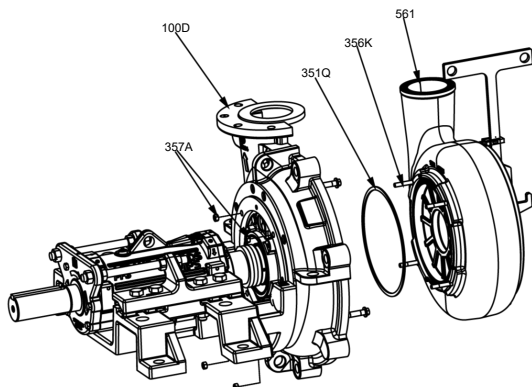

Figure 63: Removal of volute liner - metal lined

4. Remove the seal cover-to-volute liner gasket (351Q).
5. Remove the volute liner retention studs (356K) from the casing volute liner (561) using a metric stud driver.

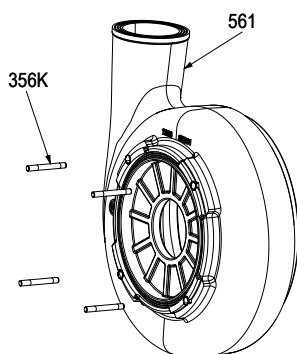

Figure 64: Removal of volute liner retention studs

6.2.7.11 Remove the expeller (optional feature)

1. Remove the impeller hub o-ring (412U).
2. Remove the expeller (263) from the shaft (122).

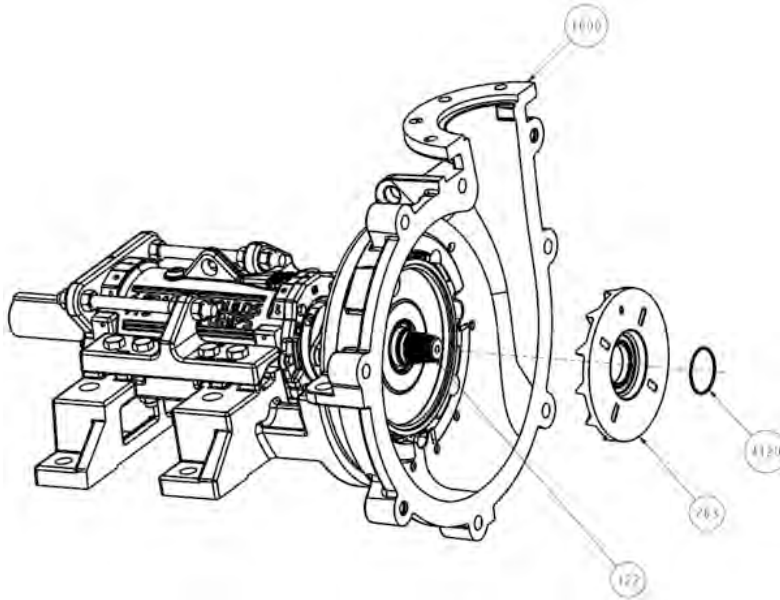

Figure 65: Removal of expeller

6.2.7.12 Remove the seal cover and gland half casing assembly

1. Remove the gland casing and seal cover assembly by supporting the casing assembly with a hoist hook through the lifting lug.

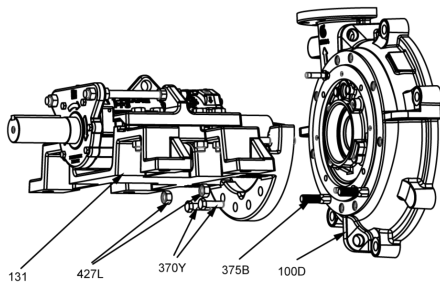

Figure 66: Removal of seal cover and half gland assembly

2. Remove the pedestal to casing (427L) and (3701) hardware.
3. Hoist the casing assembly to the ground so that the seal cover or stuffing box cover can be removed.

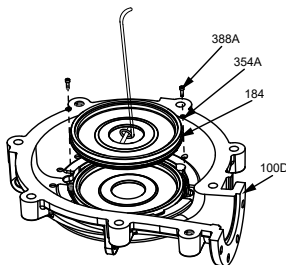

Figure 67: Seal cover removal

4. Remove the seal cover retention hex head cap screws (388A) and clipped washers (354A).
5. Remove the seal cover (184) from the gland half casing (100D). Use a short pry bar to gently and evenly facilitate disassembly if necessary.

6. Remove the seal cover o-ring (496R, XHD).

6.2.7.13 Optional disassembly of gland half casing, volute liner, and seal cover - Metal-Lined

NOTICE:

When there is no expeller assembly supplied, the Gland casing assembly can be removed and rebuilt as an assembly.

The gland half casing (100D), volute liner (561), seal cover (184), and/or split stuffing box assembly (159), can be removed as an entire assembly

1. Once the impeller is removed from the shaft, support the entire gland casing assembly with a strap, located thru the appropriate gland half casing hoisting location.
2. Loosen and remove the casing to pedestal bolts (370Y) and nuts from the taper alignment studs (427L).
3. Carefully remove the assembly and hoist to the ground to disassemble as required, using the instructions in the related sections of this instruction manual.

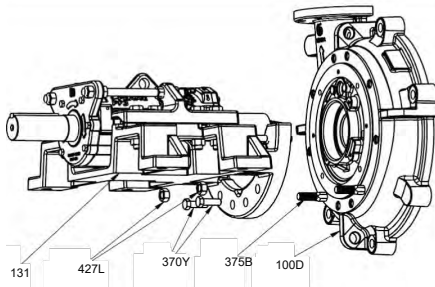

Figure 68: Removal of gland half casing

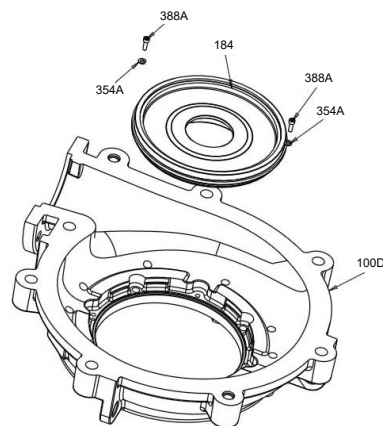

Figure 69: Removal of seal cover

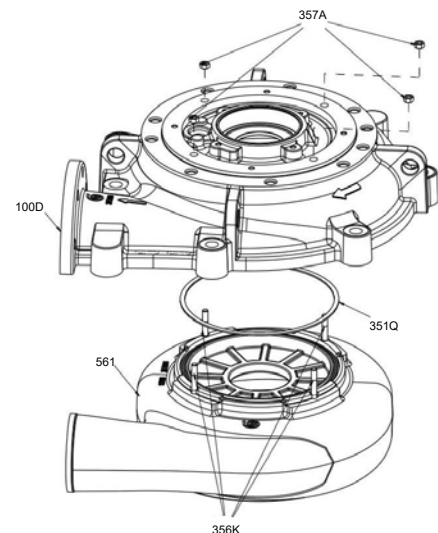

Figure 70: Removal of gland half casing

6.2.7.14 Locate and lift the volute liner for optional discharge locations (field replacement) - Metal-Lined

1. Using the ITT approved volute liner and Impeller lifting device, the Volute Liner (561) can be installed into the Gland Casing (100D) the field in any of the optional discharge orientations.
2. Remove the Suction casing and Suction Liner assembly as described in the section 'Remove the Suction Side'.

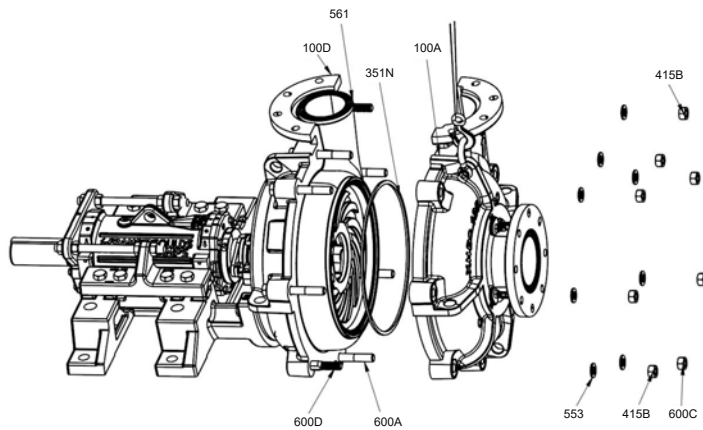

Figure 71: Suction casing removal

3. Remove the Impeller as shown in the impeller removal section.

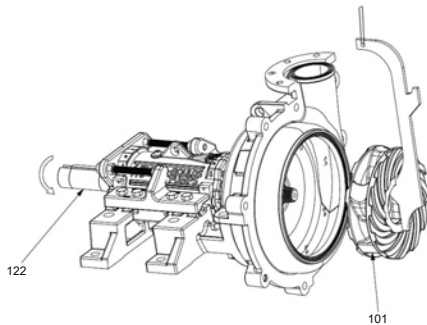

Figure 72: Impeller removal - metal lined

4. Secure the Volute Liner hook, to the Volute Liner (561) in the proper orientation, as illustrated below.

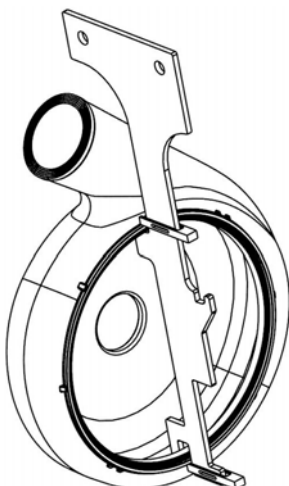

Figure 73: Volute liner replacement - alternate orientations

5. Lift the Hook and volute liner and crane into the Gland casing.
6. Be sure to locate the Volute Liner hook and upper and lower keys, and tighten the bolts thru the key to the hook. This will restrict movement of the volute liner on the hook. Failure to tighten the keys appropriately may allow the volute liner to rotate while being hoisted into the gland casing.

6.2.7.15 Remove the shaft sleeve

1. Remove the shaft sleeve (126) from the shaft (122). Use a short pry bar to gently facilitate removal, if necessary.
2. Remove the impeller hub o-ring (412A) and shaft sleeve o-ring (412F).

NOTICE:

Item (412A) Impeller O-ring is supplied only with the metal impeller.

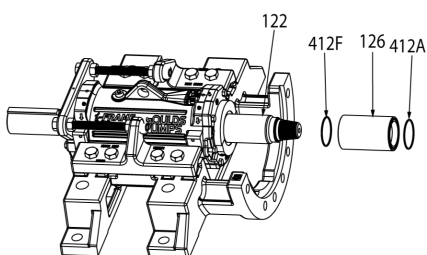

Figure 74: Removal of shaft sleeve

6.2.8 Disassembly for Rubber-Lined

The disassembly steps for Metal-lined and Rubber-lined differ. This section, beginning with *Typical disassembly* and ending with *Remove the shaft sleeve*, pertains to Rubber-lined pumps.

For Metal-lined pumps, refer to the sub-section, [6.2.4 Disassembly for Metal-Lined on page 86](#).

6.2.9 Disassembly - Rubber-Lined

The XHD Rubber lined slurry pump is currently available only with the single piece non-adjustable suction seal ring.

The suction half casing and attached components can be removed for further disassembly and replacement of the suction side liner (600R) as necessary. After removing the impeller (101) by disengaging the knock-off ring (149), the gland half casing (100D) can remain mounted to the pedestal (131) and the casing gland side liner (600T) removed for replacement. Other components such as the gland, packing, seal cover etc. can also be removed in a methodical fashion as needed for inspection and replacement.

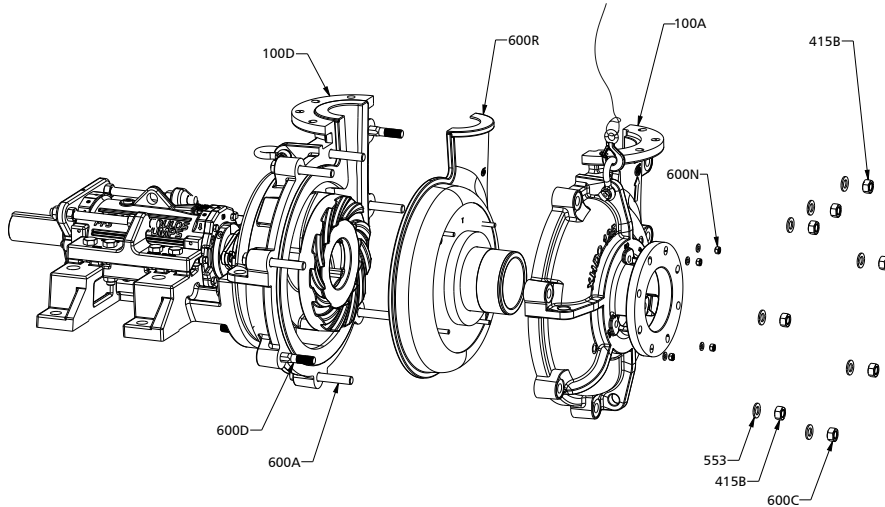

Figure 75: Gland and Suction Liner

6.2.10 Remove the joint gaskets and flanges - Rubber-Lined

NOTICE:

Gaskets 351A and 351B are supplied only with metal lined pumps. Gaskets for rubber lined pumps are integral with rubber liners.

1. Remove the two-piece suction and discharge flanges (195C, XHD sizes 150 and above only).

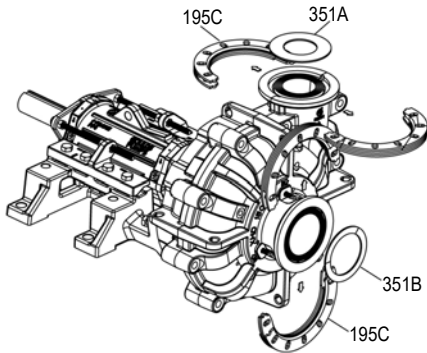

Figure 76: Joint gaskets and flanges removal

6.2.11 Remove the suction half casing - Rubber-Lined

The following parts remain attached to the suction half casing when it is removed from the rest of the pump wet end:

Model	Parts that are still attached
XHD Rubber-lined single piece suction liner	<ul style="list-style-type: none"> • Suction side liner (600R) • Hardware Hex head bolts/hex cap screws

1. Support the suction half casing (100A) with a hoist hook through the lifting lug. Tension the hoist properly so the sub-assembly will be fully supported upon disengagement.
2. Remove the casing hex head nuts (600C) and flat washers (553) from the casing hex head bolts (600A) and tapered alignment studs (600D).
3. Leave the tapered alignment studs (600D) secured in place. The studs will provide guidance in removal of the sub-assembly.
4. Guide the suction half casing (100A, with attached components) free of tapered alignment studs.

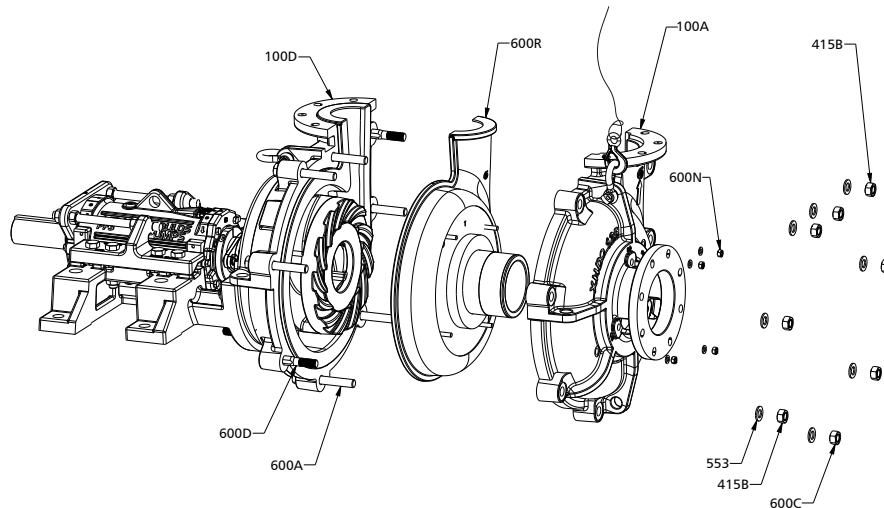

Figure 77: Gland and suction liner

5. Remove the hex head casing bolts (600A) from the gland half casing (100D).
6. Remove the tapered alignment studs (600D) from the gland half casing (100D) using a metric stud driver.

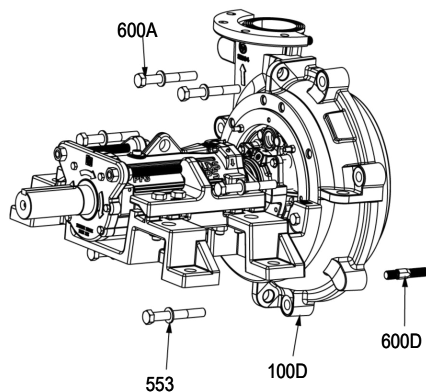

Figure 78: Removal of casing bolting

6.2.12 Remove the remaining suction half components - Rubber-Lined

Pump model	Next step to follow
XHD Value Option / Rubber-lined Single Piece Suction Liner	• Remove the suction liner

6.2.13 Remove suction side liner - XHD Single Piece Suction Liner - Rubber-Lined

1. Remove the suction side liner retention nuts (357A).
2. Remove suction side liner (600R) from suction half casing (100A).

3. Remove the suction side liner retention studs (600N) from the suction side liner (600R) using a metric stud driver.

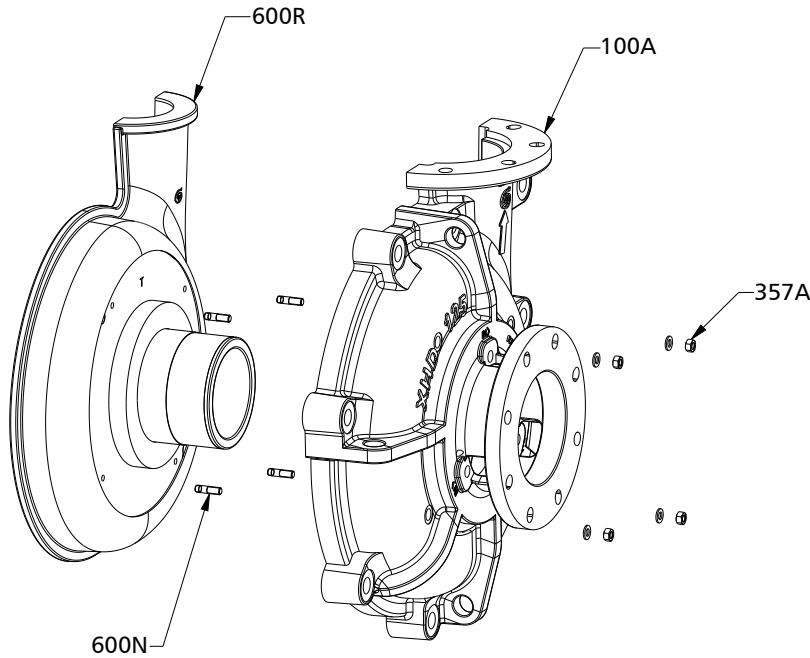

Figure 79: Suction liner removal

6.2.14 Impeller removal - Rubber-Lined

Two people should work together to remove the impeller for safety purposes.

1. Remove the gland assembly halves (107) by removing the gland adjusting bolts (353).
2. Loosen the bearing frame adjustment plate bolts (352G) and nuts (427D) but DO NOT remove hardware or adjustment plates (234F). Keep hardware finger-tight to keep the bearing frame constrained to the pedestal while allowing it to slide along the pedestal rails.

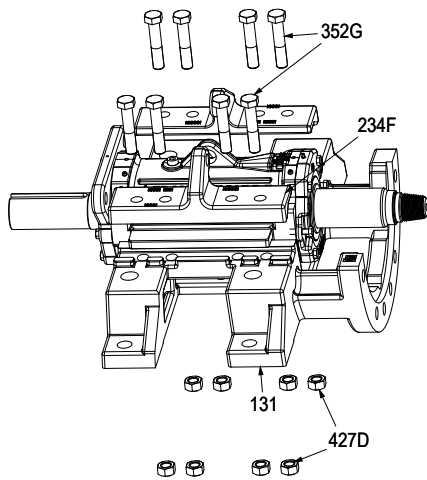

Figure 80: Bearing frame adjustment plate removal

3. Slide the bearing housing and shaft assembly forward towards the suction side of the pump to allow better access to the impeller (101).
4. Remove the two-piece knock-off ring (149).

5. Support the impeller (101) using a strap attached to the hoist. An overhead hoist chain or sling should be routed through a vane passage to support the impeller.
6. With one person holding the impeller (101) in place, the other person rotates the shaft (122) counterclockwise to unscrew the impeller. This step should take 4 to 5 complete shaft turns.
7. Guide the impeller (101) completely free of the shaft threads and casing volute liner (600T).

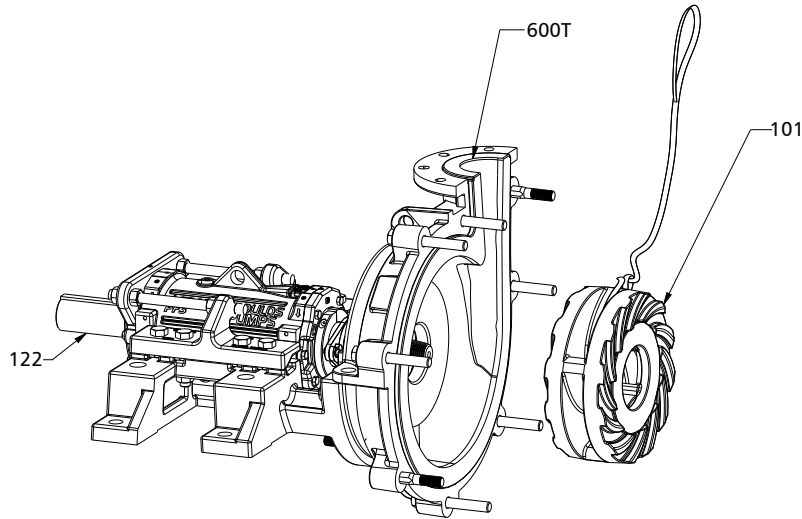
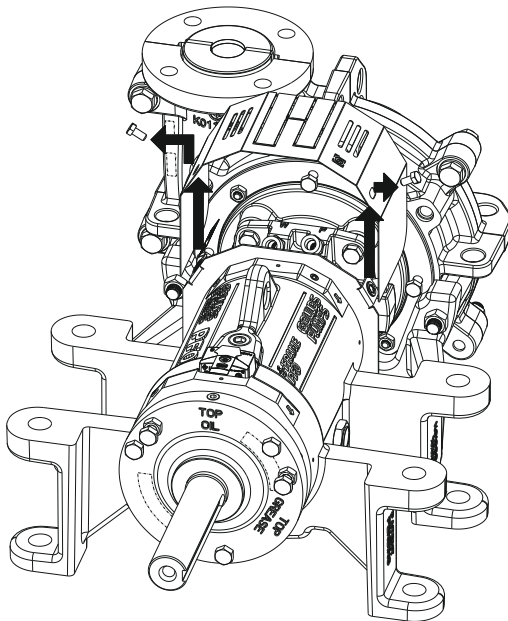

Figure 81: Impeller removal - Rubber Impeller and Strap Shown

6.2.15 Remove the shaft guard

1. Remove the bolt for each shaft guard half that mounts the halves to each side of the frame.
2. Do not remove the clip that retains the bolt on the guard to maintain a captive fastener.
3. Retain each guard half with fasteners for reinstallation.



6.2.16 Stuffing box removal

Pump Model	Next step to follow
XHD	<ul style="list-style-type: none"> The stuffing box is split and can be disassembled prior to casing volute liner removal. Continue with the Remove the split stuffing box step below.
XHD Value Option	<ul style="list-style-type: none"> The stuffing box is integral to the seal cover. Skip to the Remove the seal cover step.

6.2.17 Remove the split stuffing box XHD

NOTICE:

This section applies only to units equipped with a split stuffing box. If your unit is not equipped with a split stuffing box, the seal cover /chamber will be removed at a later step.

1. Remove the shoulder bolts (328) that hold the two halves together.
2. Remove the hex head bolts (569L) that attach the split stuffing box (159) to the seal cover (184).
3. Remove the split stuffing box halves (159).
4. Remove the split stuffing box gaskets (367B).
5. Remove the packing (106) and lantern ring (105). The lantern ring has a split cut that can be widened to accommodate removal without permanently deforming the part.

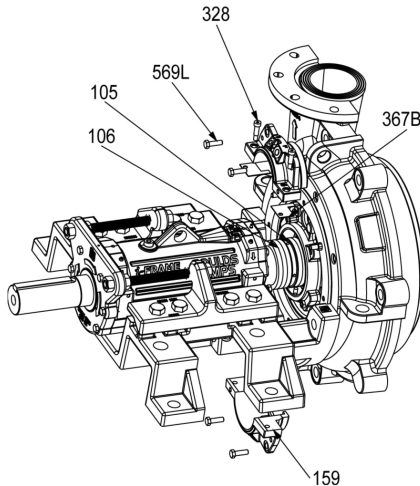

Figure 82: Removal of split stuffing box

6.2.18 Remove the casing volute liner - Rubber-Lined

NOTICE:

The casing volute liner can be removed individually using the following steps if there is an expeller installed or if there is no expeller, then the gland casing, volute liner, and seal cover can be removed as one assembly, using the instructions from the section [6.2.7.13 Optional disassembly of gland half casing, volute liner, and seal cover - Metal-Lined on page 95](#)

1. Support the casing volute liner (600T) with a Goulds-provided volute liner hook attached to the hoist.
A sling can also be routed through and around the discharge opening of the casing volute liner for support for some discharge orientations.
2. Remove the casing volute liner retention nuts (600L) from the volute liner retention studs (600L) at the back of the gland half casing (100D).

3. Move the casing volute liner (600T) out of and away from the gland half casing.

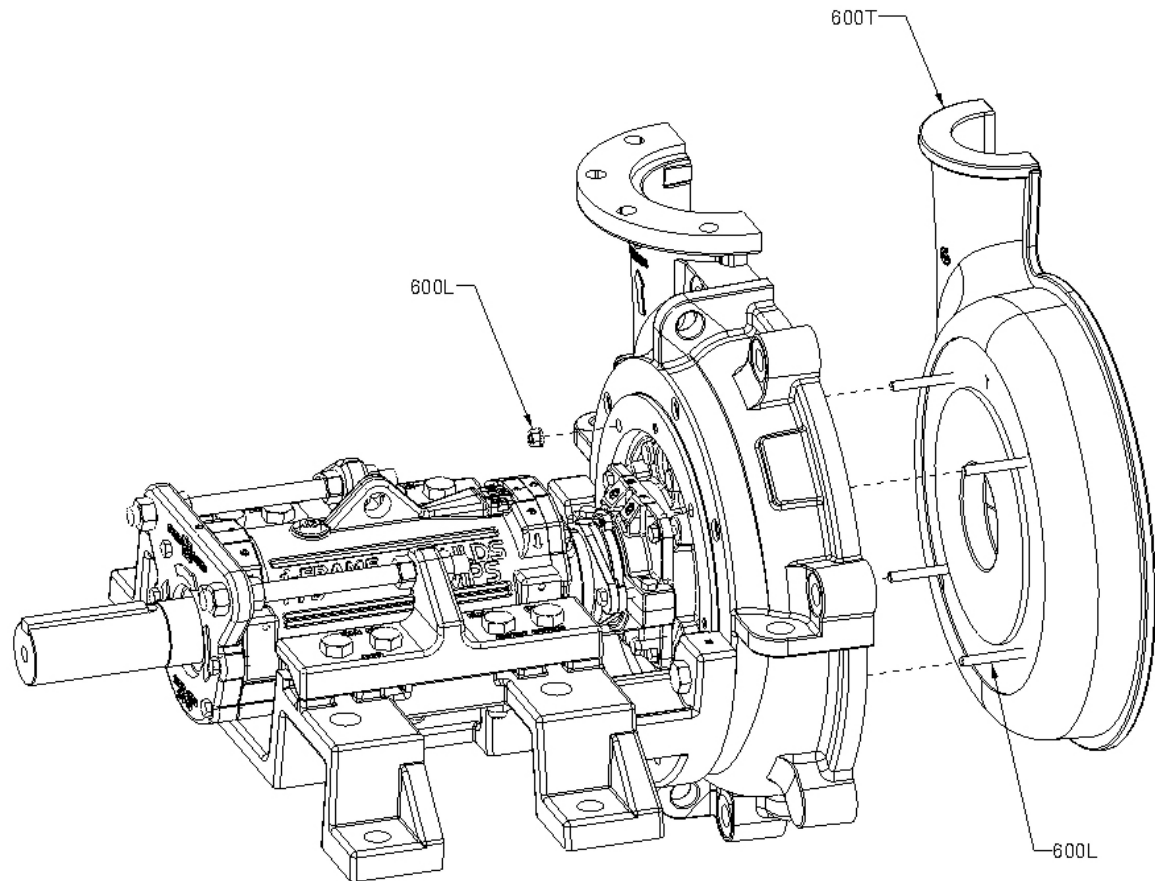

Figure 83: Rubber gland liner removal

4. Remove the volute liner retention studs (600L) from the casing volute liner (600T) using a metric stud driver.

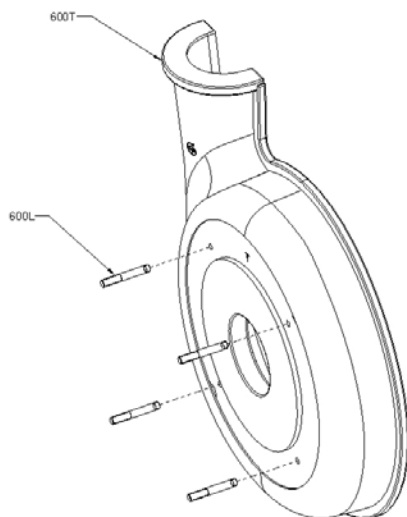

Figure 84: Rubber gland liner stud removal

6.2.19 Remove the power end - quick disconnect option for XHD

NOTICE:

The quick disconnect power end removal procedure cannot be used if the assembly does not have the Suction seal ring option installed. This quick disconnect feature may also be unavailable depending on the amount of wear on the suction seal ring and internal surfaces.

The XHD power end can be removed when the entire liquid end is still attached to the pedestal by employing the components available with the XHD complete liquid end disconnect feature. Rather than removing any portion of the wet end, it can remain assembled to the pedestal and the power end can be removed as follows:

This procedure can also be employed to change out the entire wet end while not removing the power end.

1. Loosen the forward (wet end side) bearing frame adjusting nuts (415A) by turning them clockwise.
2. Loosen the hold-down bolts (352G) and nuts (427D) that clamp the adjustment plates (234F) to the bearing cartridge housing (228) but do NOT remove.
3. Move the impeller to the back of the volute liner: Turn the two rearward (drive end side) bearing frame adjusting nuts (415A) on either side of the power frame sequentially clockwise, 1/2 turn of each nut at a time, to draw the bearing frame and impeller (101) backwards toward the volute liner (561). Stop when the impeller is firmly seated against the volute liner.
4. Loosen the three adjustable seal ring jam nuts (357A) by turning them clockwise.
5. Move the suction seal ring towards the impeller: Turn the seal ring square head adjusting bolts (356F) sequentially, counterclockwise 1/3 of a turn at a time, to move the adjustable seal ring forward in the casing until it is firmly seated against the impeller, thereby pinching the impeller between the seal ring and the volute liner.
6. Lock the seal ring adjusting bolts (356F) in place by re-tightening the jam nuts (357A) against the suction half casing (100A).
7. Loosen the knock off ring bolts and disassemble the knockoff ring halves(149) from the shaft.
8. Turn the shaft (122) counterclockwise with a strap wrench or shaft wrench to disengage the shaft threads from the impeller. This will cause the bearing frame to move rearward on the pedestal until the shaft disengages from the impeller (101) which is held captive in the casing by the adjustable seal ring and casing volute liner. NOTE: This should take 4 to 5 complete shaft turns.
9. Slide the bearing frame backwards away from the liquid end until the shaft is completely free of the liquid end.
10. Insert hoist hook through the bearing cartridge housing (228) lifting lug.
11. Remove the bearing frame adjustment plate bolts (352G) and threaded adjustment rod nuts on the outer face of the adjustment plate (234F) ears.
12. Remove and set aside the bearing frame adjustment plates (234F).
13. Tension the hoist fully to lift and move the bearing frame to designated work area.

6.2.20 Remove the expeller (optional feature)

1. Remove the impeller hub o-ring (412U).
2. Remove the expeller (263) from the shaft (122).

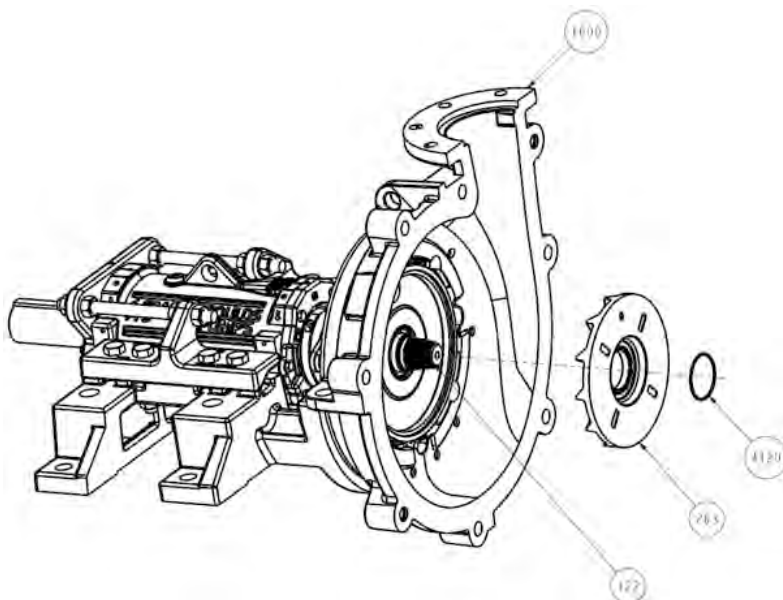

Figure 85: Removal of expeller

6.2.21 Remove the seal cover and gland half casing assembly

1. Remove the gland casing and seal cover assembly by supporting the casing assembly with a hoist hook through the lifting lug.

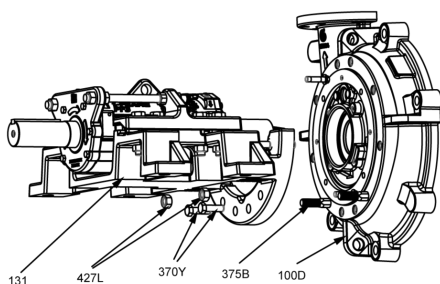

Figure 86: Removal of seal cover and half gland assembly

2. Remove the pedestal to casing (427L) and (3701) hardware.
3. Hoist the casing assembly to the ground so that the seal cover or stuffing box cover can be removed.

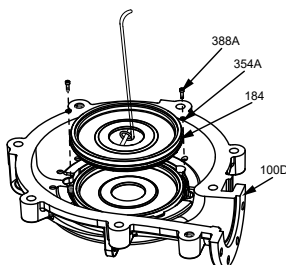

Figure 87: Seal cover removal

4. Remove the seal cover retention hex head cap screws (388A) and clipped washers (354A).
5. Remove the seal cover (184) from the gland half casing (100D). Use a short pry bar to gently and evenly facilitate disassembly if necessary.

6. Remove the seal cover o-ring (496R, XHD).

6.2.22 Optional disassembly of gland half casing, gland liner, and seal cover - Rubber-Lined

NOTICE:

When there is no expeller assembly supplied, the Gland casing assembly can be removed and rebuilt as an assembly.

The gland half casing (100D), volute liner (600T), seal cover (184), and/or split stuffing box assembly (159), can be removed as an entire assembly

1. Once the impeller is removed from the shaft, support the entire gland casing assembly with a strap, located thru the appropriate gland half casing hoisting location.
2. Loosen and remove the casing to pedestal bolts (370Y) and nuts from the taper alignment studs (427L).
3. Carefully remove the assembly and hoist to the ground to disassemble as required, using the instructions in the related sections of this instruction manual.

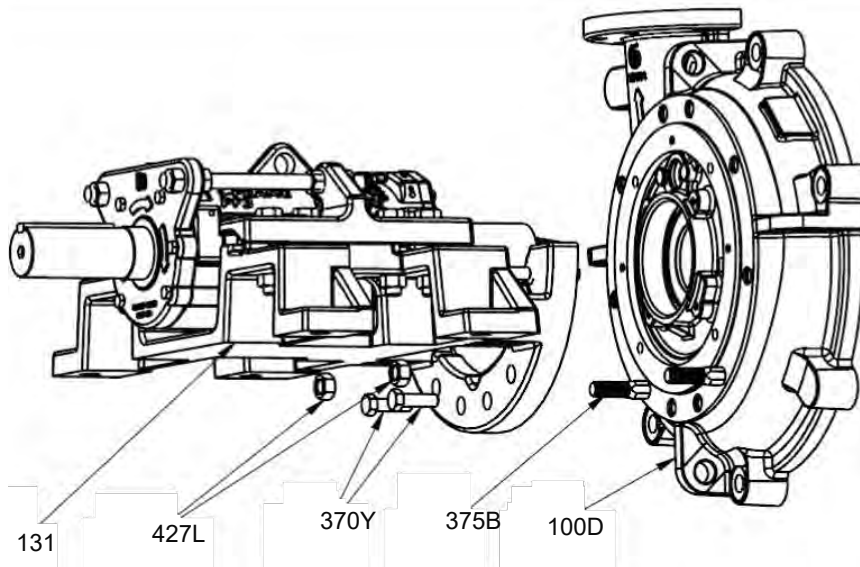

Figure 88: Removal of gland half casing

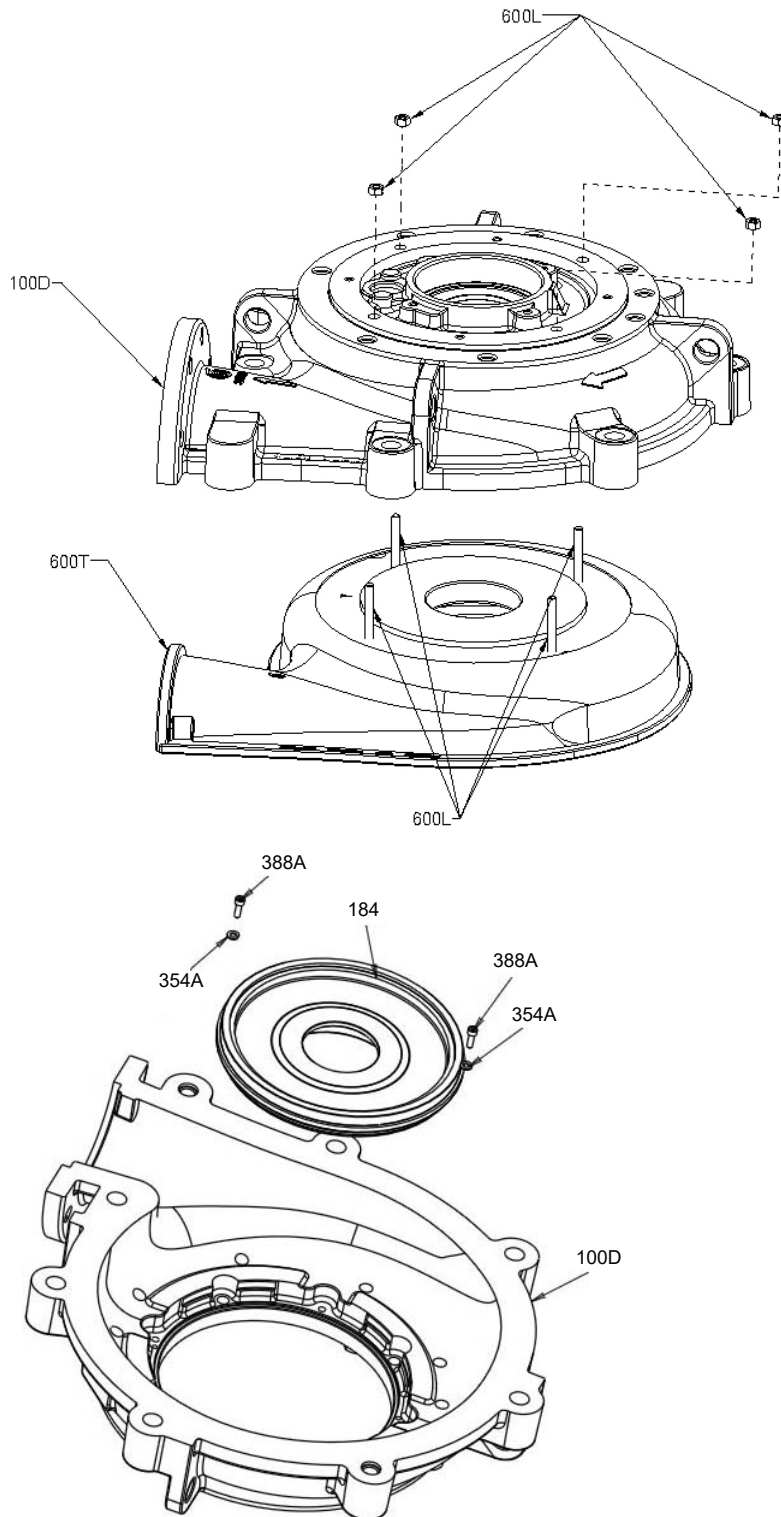

Figure 89: Gland half casing disassembly

6.2.23 Locate and lift the volute liner for optional discharge locations (field replacement) - Rubber-Lined

1. The Volute Liner (600T) can be installed into the Gland Casing (100D) the field in any of the optional discharge orientations.
2. Remove the Suction casing and Suction Liner assembly as described in the section 'Remove the Suction Side.'

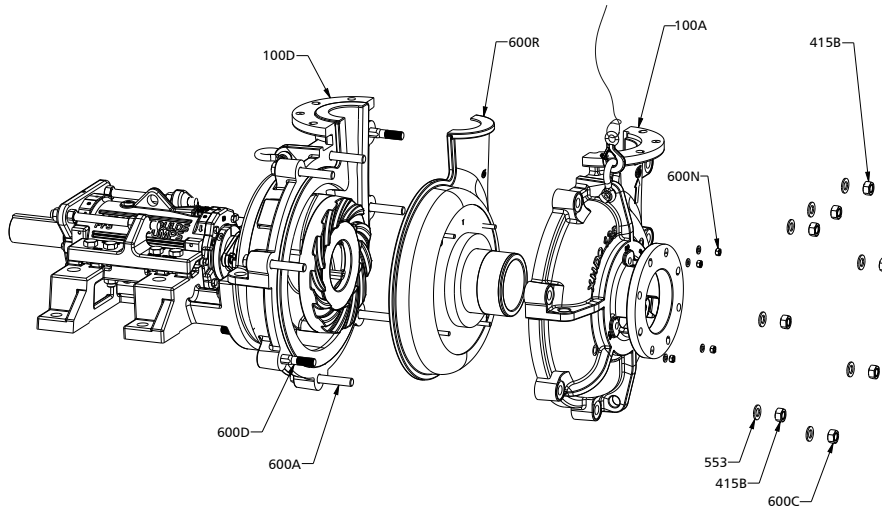

Figure 90: Volute liner and impeller lifting

3. Remove the Impeller as shown in the impeller removal section.

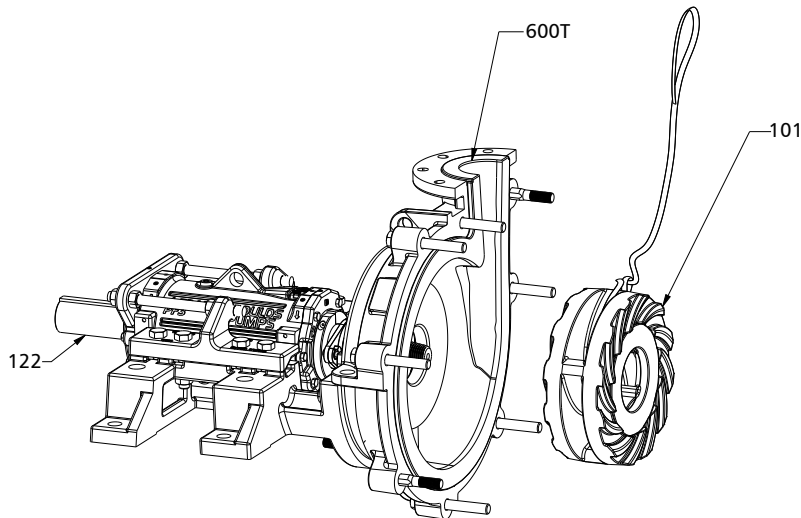

Figure 91: Impeller Removal

6.2.24 Remove the shaft sleeve

1. Remove the shaft sleeve (126) from the shaft (122). Use a short pry bar to gently facilitate removal, if necessary.
2. Remove the impeller hub o-ring (412A) and shaft sleeve o-ring (412F).

NOTICE:

Item (412A) Impeller O-ring is supplied only with the metal impeller.

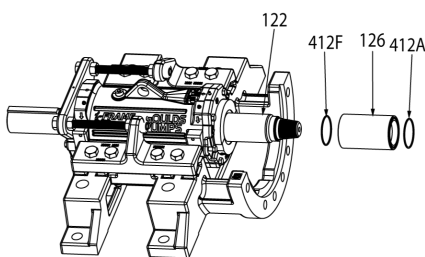

Figure 92: Removal of shaft sleeve

6.2.25 Remove the power end- XHD and XHD Value Option

Before beginning removal of the power end, check to ensure that the pedestal (131) is securely fastened to the foundation, baseplate or work surface, such as a workbench.

When removing the power end, the coupling hub or V-belt sheave on the drive end of the shaft must also be removed.

The power end of the XHD and XHD Value Option models can be removed during traditional liquid end disassembly when the suction half casing, suction side liner, adjustable seal ring (XHD only), knock off ring, impeller and gland (packing or mechanical seal) are removed. In this state, the gland half casing remains attached to the pedestal with the casing volute liner, seal cover and stuffing box still installed. Proceed as follows:

1. Drain the oil from the bearing cartridge housing (228) by removing the oil drain pipe plugs (408A).

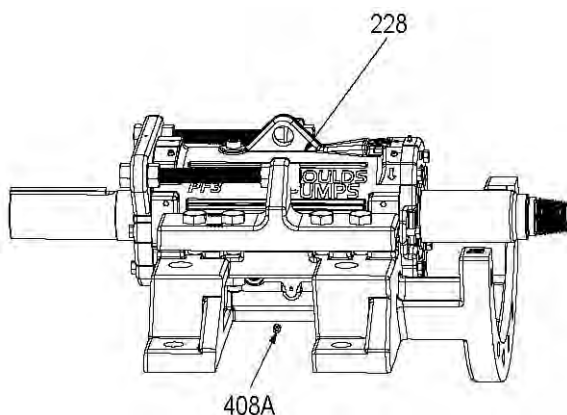

Figure 93: Oil draining from frame

2. Loosen the power end adjustment plate bolts (352G) and nuts (427D) but do not remove.
3. Slide the power end backwards away from the liquid end until the shaft is completely free of the liquid end and pedestal (131) lower half-ring.
4. Remove the outer bearing frame adjustment rod nuts (415A) and threaded rods (370X).

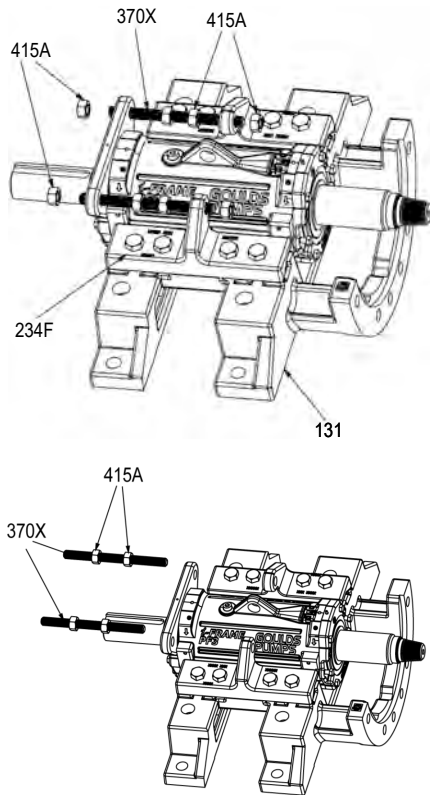

Figure 94: Frame adjustment rods

5. Insert hoist hook through the bearing cartridge housing (228) lifting lug.
6. Remove the bearing frame adjustment plate bolts (352G), nuts (427D) and bearing frame adjustment plates (234F).

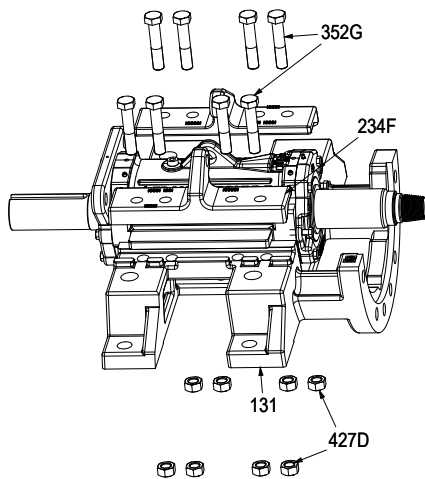

Figure 95: Removal of bearing frame hardware

7. Tension the hoist fully to lift and move the power end to designated work area.

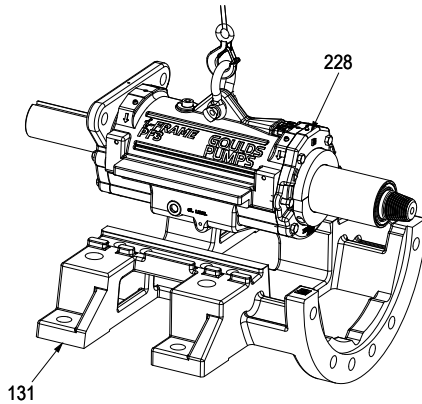

Figure 96: Lifting of power end

6.2.26 Disassemble the power end - XHD, oil lubrication

1. Remove the outboard bearing cover assembly hex head capscrews (370N).
2. Remove the outboard bearing cover (109) from the bearing cartridge housing (228) with the o-ring (412) and labyrinth seal (332A) still installed.
3. Remove the outboard labyrinth seal (332A) and o-ring (412).
4. Remove the Bellville preload washer (529).

Important: Always remove the outboard bearing cover assembly and Bellville washer first. This will remove the preload from the rotating element assembly for easier removal of the remaining bearing frame components.

NOTICE:

A tapped hole is provided in the coupling end of the shaft, to allow for vertical assembly and disassembly of the power frame components. This will provide a location to hold the shaft and withdraw from the frame in the vertical position.

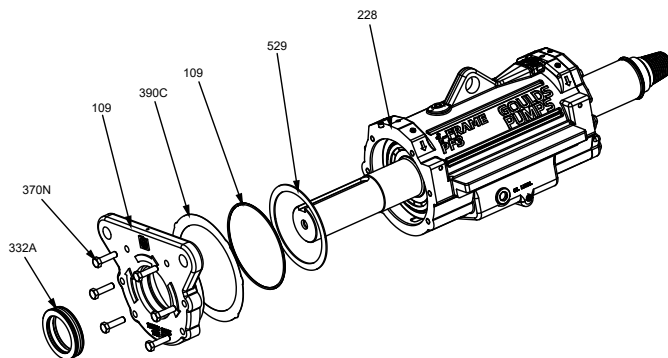

Figure 97: Power frame disassembly

Once the outboard bearing end cover related components are removed, the shaft can be withdrawn from the frame while in the vertical position.

5. Remove the inboard bearing cover assembly hex head capscrews (370P).
6. Remove the inboard bearing cover (119) from the bearing cartridge housing (228) with the o-ring (412), labyrinth seal (333A) and shims (390C) still installed.
7. Remove the inboard labyrinth seal (333A) and o-ring (412).

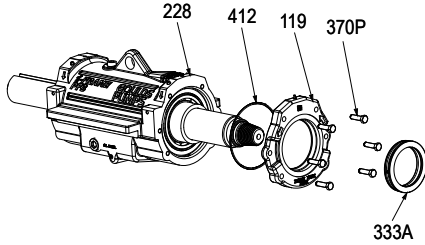

Figure 98: Removal of labyrinth seal

8. Slide the rotating element assembly from the bearing cartridge housing (228), using the lifting hoist in the coupling end of the shaft to retract the assembly from the frame. Lifting hole sizes are specified below.

Pump Size	Frame Size	Shaft lifting hole thread size
XHD50, XHD75	PF1	M16 x 2
XHD80	PF2	M16 x 2
XHD100, XHD125	PF3	M16 x 2
XHD150	PF4/PF4S	M24 x 3
XHD200	PF4/PF4S	M24 x 3
XHD250	PF5	M24 x 3
XHD300	PF5	M24 x 3

Note: The drive/outboard end of the shaft contains a threaded hole for eye bolt attachment which can aid in rotating element removal.

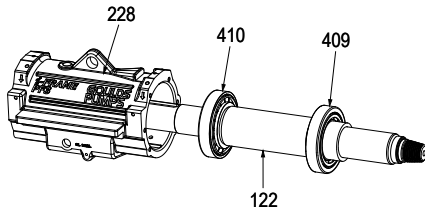

Figure 99: Rotating element removal

9. Remove the spacer sleeve (157) and spacer sleeve o-rings (512D).
10. Remove the inboard and outboard taper roller bearings (409 and 410) using a suitable puller that only contacts the inner races of the bearings.

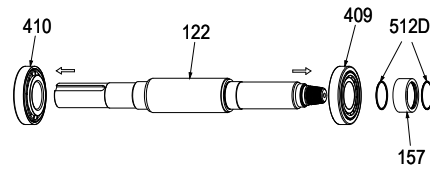

Figure 100: Bearing removal

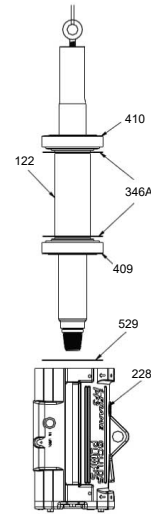

Figure 101: Vertical rotating element removal

11. Remove and clean or replace bulls eye sight glass (319) and opposite sight glass (408N) if necessary.

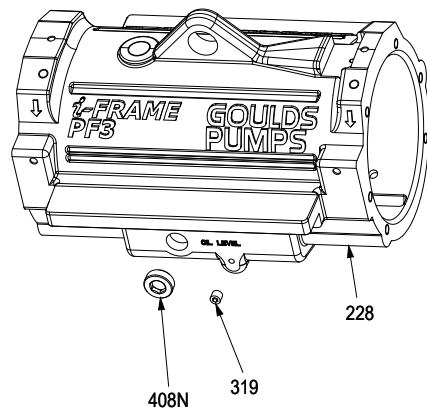

Figure 102: Bulls eye sight glass

6.2.27 Disassembly of other power end configurations

The disassembly of other available power end configurations is very similar to that of the XHD oil-lubricated power end. All of the major pieces of the power end (bearing cartridge, end covers, bearings, etc.) are designed for use with all options so only a few components will change regardless of the type of lubrication or isolators used.

The following subsections highlight the main differences in the disassembly of power end configurations other than the XHD oil-lubricated power end.

Disassemble the power end XHD, grease lubrication

- Regardless of the type of lubrication, the XHD power end uses labyrinth (Inpro) seals as bearing isolators. Disassembly of the end covers and isolators will follow the same procedure as that of the XHD oil-lubricated version.
- The only major difference between oil and grease lubricated power ends for the XHD is the use of grease shields, as shown on the figure below. During disassembly these can be removed, inspected and replaced as necessary.

- There are also grease fitting plugs (319H) and grease relief plugs (319Y) installed into the bearing cartridge housing (228) used for purging and regreasing the grease lubricated XHD power end. During disassembly these fittings can be removed, inspected and replaced as necessary.
- There will be no sight glass (319) or opposite sight glass (408N) on the grease lubricated power end.

Disassemble the power end XHD Value Option, oil lubrication

- The XHD oil lubricated power end uses double lip seals as bearing isolators. Instead of pipe plugs, there will be grease fitting plugs in the bearing cartridge end covers for the addition of grease as necessary to maintain the double lip seal contaminant barrier.
- The double lip seals have the same fits as the labyrinth seal isolators used on the XHD power end. There is no difference in the end covers between these or any of the power ends, regardless of the type of lubrication and basic/fully featured model. The lip seals can be removed in the same manner as described for the XHD power end.

Disassemble the power end XHD, grease lubrication

- The XHD grease lubricated power end also uses double lip seals as bearing isolators. The same bearing shields employed on the XHD grease lubricated power end are used as well to properly maintain grease in the bearings. The bearing shields can be removed, inspected and replaced in the same manner as shown for the XHD grease lubricated power end.
- Because of the need to provide grease to both the double lip seal bearing isolators and the bearings themselves, there are grease fitting plugs (319H) installed in both the bearing cartridge housing (228) and the inboard and outboard bearing end covers (109 and 119). There are also grease relief plugs (319Y) installed in the bottom of the bearing cartridge housing (228) for purging and regreasing of the bearings.
- There will be no sight glass (319) or opposite sight glass (408N) on the grease lubricated power end.

6.2.28 Guidelines for i-ALERT[®] Equipment Health Monitor disposal

Precautions



WARNING:

- Explosive hazard and risk of personal injury. Heating to high temperatures could cause combustion of the condition monitor. Never heat the condition monitor to temperatures in excess of 149°C | 300°F or dispose of in a fire.
-

Guidelines

The battery contained in the condition monitor does not contain enough lithium to qualify as reactive hazardous waste. Use these guidelines when disposing of the condition monitor.

- The condition monitor is safe for disposal in the normal municipal waste stream.
- Adhere to local laws when you dispose of the condition monitor.

6.3 Preassembly inspections

6.3.1 Replacement guidelines

Casing and liners check and replacement



WARNING:

Risk of death or serious injury. Leaking fluid can cause fire and/or burns. Inspect and ensure gasket sealing surfaces are not damaged and repair or replace as necessary.

Inspect the casing and liners for cracks and excessive wear or pitting. Thoroughly clean gasket surfaces and alignment fits in order to remove rust and debris.

Casing areas to inspect

The arrows point to the areas to inspect for wear on the casing:

Impeller replacement

This table shows the criteria for replacing the impeller:

Impeller parts	When to replace
Vane edges	When you see cracks, pitting, or corrosion damage

Gaskets, O-rings, and seats replacement



WARNING:

Risk of death or serious injury. Leaking fluid can cause fire and/or burns. Replace all gaskets and O-rings at each overhaul or disassembly.



WARNING:

Risk of serious personal injury or property damage. Fasteners such as bolts and nuts are critical to the safe and reliable operation of the product. Ensure appropriate use of fasteners during installation or reassembly of the unit.

- Use fasteners of the proper size and material only.
- Replace all corroded fasteners.
- Ensure that all fasteners are properly tightened and that there are no missing fasteners.

Stuffing box cover and seal chamber replacement

- Thoroughly clean the gasket surfaces and fits to remove rust and debris.
- Inspect surfaces for pitting, and excessive wear or corrosion damage.

6.3.2 Fastening



WARNING:

Risk of serious personal injury or property damage. Fasteners such as bolts and nuts are critical to the safe and reliable operation of the product. Ensure appropriate use of fasteners during installation or reassembly of the unit.

- Use fasteners of the proper size and material only.
- Replace all corroded fasteners.

- Ensure that all fasteners are properly tightened and that there are no missing fasteners.

6.3.3 Power end inspection

Checklist

Check the bearing frame for these conditions:

- Visually inspect the bearing frame and frame foot for cracks.
- Check the inside surfaces of the frame for rust, scale, or debris. Remove all loose and foreign material.
- Make sure that all lubrication passages are clear.
- If the frame has been exposed to pumped fluid, inspect the frame for corrosion or pitting.
- Inspect the inboard-bearing bores.

If any bores are outside the measurements in the Bearing fits and tolerances table, replace the bearing frame.

- Inspect the shafts and sleeves for wear.
- Inspect the labyrinth seal O-rings for cuts and cracks.

6.4 Reassembly

6.4.1 Assemble the power end- XHD, oil lubrication

NOTICE:

Do not use a flame to heat bearings. Doing so will damage the bearing surfaces.

1. Install the bearings onto the shaft (items 346A grease shields shown below are for grease lube only):
 - a) Use an induction bearing heater to heat the bearings to approximately 121°C | 250°F . This expands the bearings to ease their installation on the shaft.
 - b) Install the inboard and outboard taper roller bearings (409 and 410) onto the shaft (122) in a face-to-face orientation.
 - c) Push the inner races firmly against the shaft shoulders until the bearings cool and are locked into place.

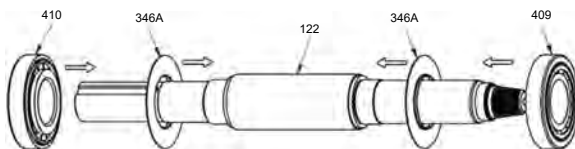

Figure 103: Installation of bearings onto shaft

2. Lubricate and install the spacer sleeve o-rings (512D) into the spacer sleeve (157).
3. Slide the spacer sleeve (157) onto the inboard end of the shaft (122) until it is flush with the inner race of the inboard taper roller bearing (409). Use care when sliding the spacer sleeve onto the shaft to prevent o-ring damage.
4. Coat the outside bearing races with oil to ensure they float in the frame.
5. Insert the inboard labyrinth seal (333A) into the inboard bearing cover (119).
6. Lubricate the inboard bearing cover o-ring (412) and insert into the inboard bearing cover (119).

7. Insert the Bellville preload washer (529) into the inboard end of the bearing cartridge housing (228) so it is in contact with the inboard taper roller bearing (410).
8. Slide the inboard bearing cover (with Inpro seal and o-ring attached) into the bearing cartridge housing (228) carefully to avoid o-ring damage.
9. Secure the inboard cover assembly to the bearing cartridge housing (228) using the hex head cap screws (370P).

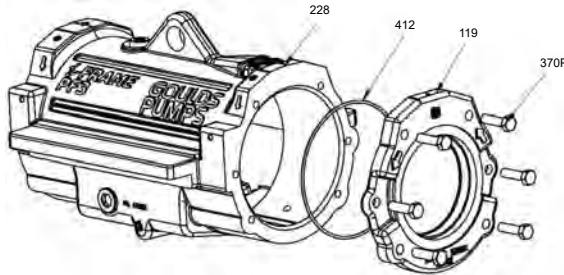

Figure 104: Secure inboard cover assembly

10. Slide the bellville washer (529) and outer race of the inboard bearing (409) into position inside the bearing frame (228).
11. Slide the rotating element assembly into the bearing cartridge housing (228), inboard end first using the lifting hoist in the coupling end of the shaft to lift the assembly until the inboard bearing (409) contacts the bellville washer (529). Lifting hole sizes are specified below.

Pump Size	Frame Size	Shaft lifting hole thread size
XHD50, XHD75	PF1	M16x2
XHD80	PF2	M16x2
XHD100, XHD125	PF3	M16x2
XHD150	PF4	M24x3
XHD200	PF4	M24x3
XHD250	PF5	M24x3
XHD300	PF5	M24x3

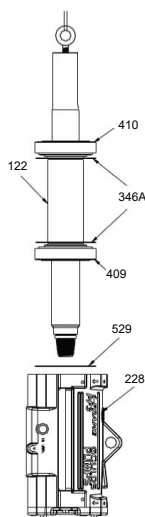
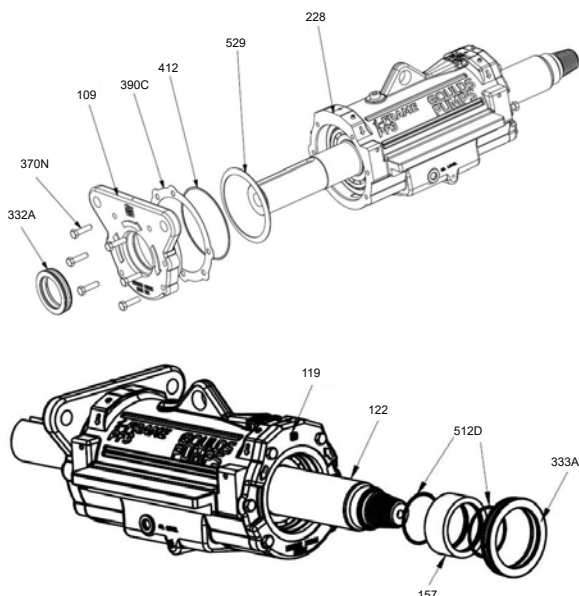

Figure 105: Vertical rotating element assembly

12. Insert the Bellville preload washer (529) into the outboard end of the bearing cartridge housing (228) so it is in contact with the outboard taper roller bearing (410). Grease shield 346A shown above is for grease lube only.
13. Insert the outboard labyrinth seal (332A) into the outboard bearing cover (109).
14. Lubricate the outboard bearing cover o-ring (412) and insert into the outboard bearing cover (109).
15. Slide the outboard bearing cover (with seal and o-ring attached) into the bearing cartridge housing (228) carefully to avoid o-ring damage.
16. Tighten the outboard bearing cover assembly to the bearing cartridge housing (228) using the hex head cap screws (370N) until the bearing end cover eliminates all end play. The shaft will no longer rotate. There will be a gap between the end cover and the bearing frame. This represents zero bearing clearance in the assembly.
17. At the point where the shaft no longer turns and there is zero bearing clearance, measure gap between face of bearing end cover (109) and the face of the frame with feeler gages.
18. Select and measure shim pack such that the thickness of the shims are equal to the gap measured in (17) above plus .50 mm | 0.020" added shim. Be sure to measure in several places to assure a uniform end cover gap is being measured.
19. Remove the end cover (109) and add the shim pack (390C) noted above to the assembly. Lubricate the bearings before reassembling.
20. Secure the outboard bearing cover assembly to the bearing cartridge housing (228) using the hex head cap screws (370N). Rotate the shaft several times during the final tightening of the hex cap screws (370N) to assure a uniform assembly. The shaft should rotate by hand.

**WARNING:**

- Failure to provide the proper shimming to adequately preload the taper roller bearings, will result in high bearing temperature.
- Rotate shaft by hand to ensure it rotates smoothly and there is no rubbing which could lead to excess heat generation, sparks and premature failure.

**Figure 106: Outboard bearing cover assembly**

21. Insert the shaft key (400) into the keyway in the outboard end of the shaft (122).
22. Install the bulls eye sight glass (319) and plug, opposite (408N) into the bearing cartridge housing (228) if removed previously.

23. Insert the oil drain plugs (408A) and the oil fill pipe plug (319B) into the bearing cartridge housing (228).

6.4.2 Assemble the power end to the pedestal

1. Apply anti-seizing compound to the pedestal (131) rails that support the power end.
2. Attach the hoist hook to the bearing cartridge housing (228) lifting lug.
3. Place the power end into position on the pedestal (131).

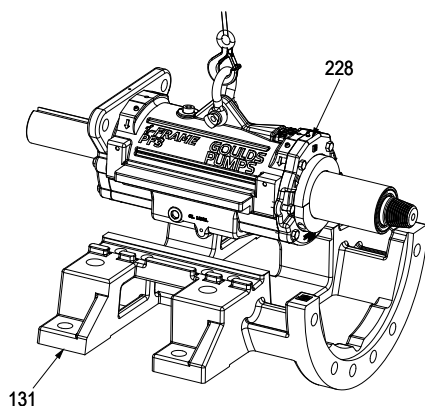

Figure 107: Power end to pedestal assembly

4. Place the bearing frame adjustment plates (234F) onto the pedestal (131) and bearing cartridge housing (228) rails.
5. Hand tighten the bearing frame adjustment plates (234F) to the pedestal (131) using the adjustment plate hex bolts (352G) and nuts (427D).

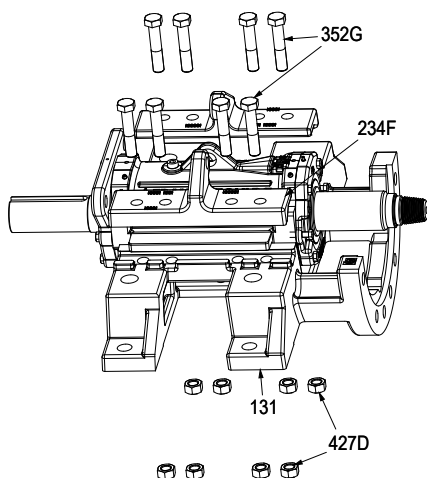

Figure 108: Frame adjustment plate bolting pre-assembly

6. Insert the free ends of the threaded adjustment rods (370X) through the bearing frame adjustment plate (234F) and outboard end cover (109) ears.

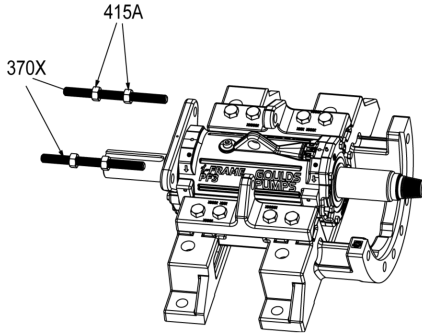

Figure 109: Adjustment rod assembly

7. Secure the threaded adjustment rods (370X) to the bearing frame adjustment plates (234F) and outboard end cover (109) by installing the hex nuts (415A) on the outer face of the adjustment plate and end cover ears.

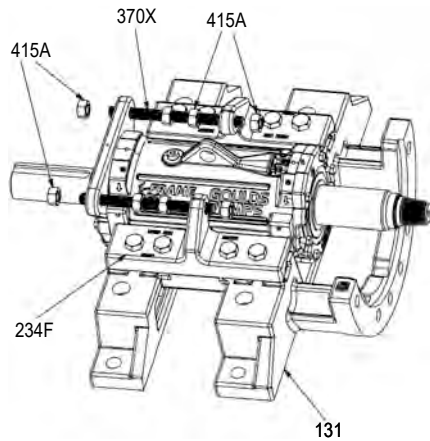

Figure 110: Adjustment rod assembly

8. Turn the inner threaded adjustment rod hex nuts (415A) until in place against the inner surfaces of the outboard bearing end cover (109) and adjustment plate (234F) ears.

6.4.3 Assembly of other power end configurations

The assembly of other available power end configurations is very similar to that of the XHD oil lubricated power end. All of the major pieces of the power end (bearing cartridge, end covers, bearings, etc.) are designed for use with all options so only a few components will change regardless of the type of lubrication or isolators used.

The following subsections highlight the main differences in the assembly of power end configurations other than the XHD oil lubricated power end.

Assemble the power end - XHD, grease lubrication, isolators

- Regardless of the type of lubrication, the XHD power end uses labyrinth seals as bearing isolators. Assembling the end covers and isolators will follow the same procedure as that of the XHD oil lubricated version.
- The only major difference between oil and grease lubricated power ends for the XHD is the use of grease shields (346A), as shown on the figures below.

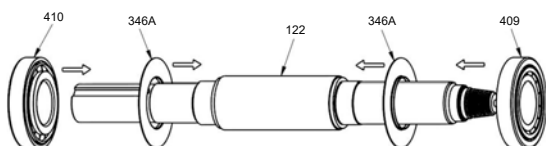

Figure 111: Bearing assembly

- There are also grease fitting plugs (319H) and grease relief plugs (319Y) installed into the bearing cartridge housing (228) used for purging and regreasing the grease lubricated XHD XL power end.
- There will be no sight glass (319) or opposite sight glass (408N) on the grease lubricated power end

6.4.4 Wet end assembly instructions



WARNING:

Before assembling the pump wet end to pedestal and power end, check to ensure that the pedestal is securely fastened to the foundation, baseplate or work surface (such as a workbench). Also ensure that the bearing frame is securely assembled to the pedestal. Failure to do so could result in injury or part(s) damage.

NOTICE:

When there is an expeller assembly supplied, the Wet End Assembly is not applicable.

In large part, steps taken to disassemble the wet end are used in reverse to reassemble the wet end to the pedestal and bearing frame, and are outlined here. In addition, an entire assembled wet end can be replaced on the XHD model as outlined in the section [6.4.5 Complete wet end connection - XHD on page 121](#).

NOTICE: If you are reassembling an XHD Value Option model, skip the next section describing the complete wet end connection and move onto [6.4.6 Wet end assembly instructions on page 122](#). You can also skip the wet end connection section if you have an XHD, have disassembled the wet end piece-by-piece, and do not have a complete wet end to assemble to the pedestal and bearing frame.

6.4.5 Complete wet end connection - XHD

ⓧ The XHD model features a "quick connect" wet end option. If you have received a complete replacement wet end from the factory or your distributor, installation of the entire wet end to the pedestal and bearing frame can be performed as follows:

NOTICE:

The quick connect wet end assembly procedure cannot be used if the assembly does not have the Suction seal ring option installed. This quick disconnect feature may also be unavailable depending on the amount of wear on the suction seal ring and internal surfaces.

The quick connect wet end method uses the Adjustable Suction seal ring to clamp into the impeller and hold it in place during the assembly.

1. Coat the shaft (122) protuberance, including the threads, with an anti-seizing compound.
2. Loosen but do not remove the hex head screws holding the knock-off ring (149) halves together.
3. Position the knock-off ring onto the shaft (122). Make sure that the part is properly oriented. The larger diameter step of the knock-off ring should face the bearing cartridge housing (228).
4. Slide the knock-off ring towards the bearing cartridge housing until it is flush with the inboard end cover (160). The knock-off ring fits over the inboard Inpro seal (332A).
5. Tighten the knock-off ring hex cap screws to secure.

6. Prepare the shaft sleeve (126) by coating the sleeve o-ring (412F) and impeller hub o-ring (412A) with a lubricant and install into the inner diameter and impeller end o-ring grooves.
7. Slide the shaft sleeve with the impeller hub o-ring properly positioned (facing outward) onto the shaft. Use care when positioning the sleeve on the shaft to avoid ID o-ring damage.
8. Continue sliding the sleeve until it is fully seated in the knock-off ring. Use a soft blow mallet to gently tap the sleeve along the shaft if necessary.
9. Insert the tapered alignment studs (375B) into the rear of the gland half casing (100D) using a metric stud driver.
10. Attach the hoist hook to the gland half casing (100D) lifting lug and tension to support the wet end.
11. Lift the wet end into position against the pedestal (131). Guide the installed tapered alignment studs through the pedestal holes on the sides of the bearing frame.
12. Attach the wet end to the pedestal by installing and fully tightening the alignment stud hex nuts (427L).
13. Fully secure the wet end to the pedestal by installing the hex head capscrews (370Y) through the holes in the pedestal's lower front ring into the gland half casing (100D).
14. Loosen the bearing adjustment frame threaded rod nuts (415A) on the forward (wet end) side of the adjustment plates by turning them clockwise.
15. Loosen the hold-down bolts (352G) and nuts (427D) that clamp the adjustment plates (234F) to the bearing cartridge housing (228) but do NOT remove. Bolts should remain finger-tightened to keep the bearing frame constrained to the pedestal while allowing it to slide along the pedestal rails.
16. Slide the bearing frame forward until the shaft (122) threads are inside the wet end and engaged with the impeller (101).
17. Turn the shaft (122) clockwise to re-engage the shaft threads to the impeller. This will cause the bearing frame to move forward on the pedestal until the shaft is fully threaded to the impeller. Note: This will take 4 - 5 complete shaft turns.
18. Loosen the three adjustable seal ring jam nuts (357A) by turning them clockwise.
19. Turn the seal ring square head adjusting bolts (356F) sequentially, clockwise 1/3 of a turn at a time, to move the adjustable seal ring backward in the casing until it is firmly seated against the suction side liner (562).
20. Adjust the impeller gap (refer to the Maintenance section for instructions).
21. Fully tighten the hold-down bolts (352G) and nut (427D) that clamp the adjustment plates (234F) to the bearing cartridge housing (228).
22. Tighten the bearing adjustment frame threaded rod nuts (415A) on the forward (wet end) side of the adjustment plates by turning them counterclockwise.
23. Adjust the seal ring gap (refer to the Maintenance section for instructions).
24. Install the packing (106) and lantern ring (105).
25. Assemble and install the gland assembly (107) using the gland adjusting bolts (353).

6.4.6 Wet end assembly instructions

The following steps are used to assemble the wet end in sequential fashion for the XHD Value Option model, as well as the XHD model when the complete wet end connection option is not employed.

6.4.6.1 Install the knock-off ring

1. Coat the shaft (122) protuberance with an anti-seize compound.
2. Loosen but do not remove the hex head screws holding the knock-off ring assembly (149) halves together.
3. Position the knock-off ring onto the shaft (122) and make sure that the part is properly oriented. The side of the knock-off ring that should face the impeller is marked "THIS SIDE OUT".
4. Slide the knock-off ring towards the bearing cartridge housing until it is flush with the inboard end cover (119). Be sure to assemble the knock-off ring (149) such that the words "this side out" can be read from the threaded end of the shaft.

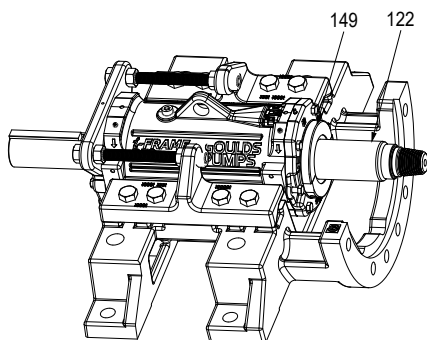

Figure 112: Knock off ring installation

On the XHD model, the knock-off ring will fit over the inboard Inpro seal (332A).

6.4.6.2 Install the shaft sleeve

1. Prepare the shaft sleeve (126) by coating the shaft sleeve o-ring (412F) and impeller hub o-ring (412A) with a lubricant and installing the o-rings into the sleeve.
2. Slide the shaft sleeve (126) with the impeller hub o-ring (412A) properly positioned (facing outward) onto the shaft. Use care positioning the sleeve on the shaft to avoid any o-ring damage.
3. Continue sliding the sleeve until it is fully seated in the knock-off ring. (Sleeve to Impeller Oring (412A) is not required with Rubber lined components.) Use a soft blow mallet to gently tap the sleeve along the shaft if necessary.

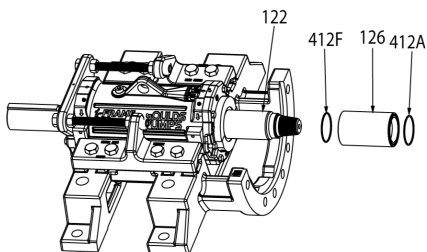

Figure 113: Shaft sleeve installation

Pump model	Next step to follow
XHD	<ul style="list-style-type: none"> • You will need to assemble the two split stuffing box halves before attaching the stuffing box to the seal cover. Start with the next step, Assemble the split stuffing box.
XHD Value Option	<ul style="list-style-type: none"> • Go to Install the seal cover instructions.

6.4.6.3 Install the gland half casing and seal cover

1. Install the tapered alignment studs (375B) into the gland half casing (100D) using a metric stud driver.

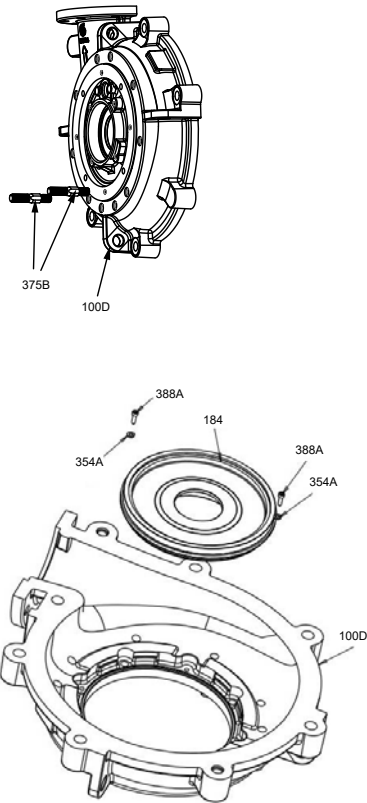

Figure 114: Gland half casing and seal cover installation

- a) Install the seal cover into the casing.
- b) With bolts and clipped washers (354A) (388A).
2. Attach the hoist hook to the gland half casing (100D) lifting lug, such that the casing discharge will be oriented properly for the application.
3. Lift the gland half casing (100D) into position and move forward until it is flush with the pedestal (131) by guiding the tapered alignment studs through the pedestal flanges.
4. Install the hex nuts (427D) onto the tapered alignment studs (375B).
5. Install the hex head capscrews (370Y) through the pedestal flange into the gland half casing (100D) to complete assembly.

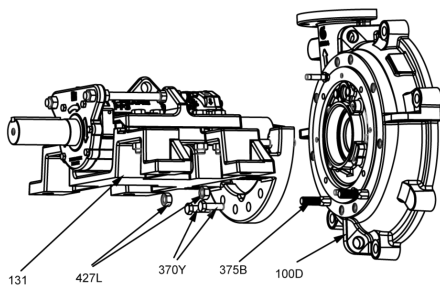

Figure 115: Capscrew installation through pedestal flange into gland half casing

6.4.6.4 Stuffing box assembly and installation

Pump model	Next step to follow
XHD Value Option	<ul style="list-style-type: none"> • Go to Install the seal cover instructions.

XHD	<ul style="list-style-type: none"> You will need to assemble the two split stuffing box halves before attaching the stuffing box to the seal cover. Start with the next step, Assemble the split stuffing box.
-----	---

6.4.6.5 Install the seal cover

- Lubricate and install the seal cover-to-casing volute liner gasket (351Q) onto the seal cover (184).
- Attach the seal cover (184) to the gland half casing (100D) using the seal cover retention socket head cap screws (388A) and clipped washers (354A).

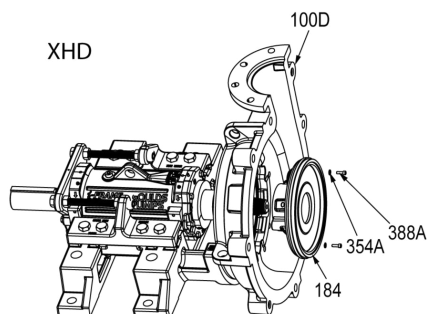

Figure 116: Seal cover installation

6.4.6.6 Assemble the split stuffing box - XHD

- Position the flat gaskets (367B) between the two halves of the split stuffing box (159).
- Assemble the two halves of the split stuffing box (with gaskets in place) using the stuffing box shoulder bolts (328). Apply a liberal coating of silicone sealant to both faces of the split stuffing box before the gasket is installed.
- Attach the stuffing box (159) to the seal cover (184) using the stuffing box-to-seal cover hex head cap screws (569L).

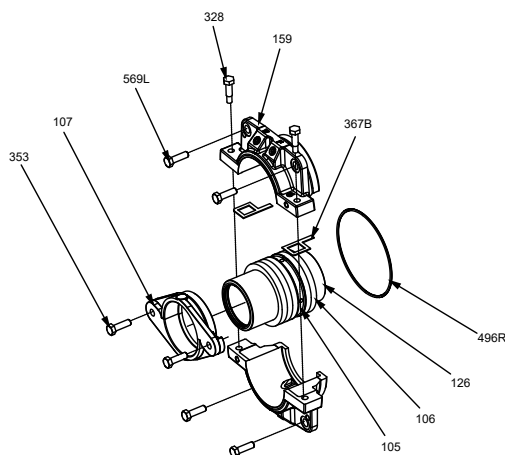

Figure 117: Attachment of stuffing box to seal cover

- Trim edges of the stuffing box gasket such that they will not interfere with the stuffing box oring.
- Lubricate and install the seal cover-to-stuffing box o-ring (496R) into the seal cover (184).
- Attach the stuffing box (159) to the seal cover (184) using the stuffing box-to-seal cover hex head cap screws (569L).

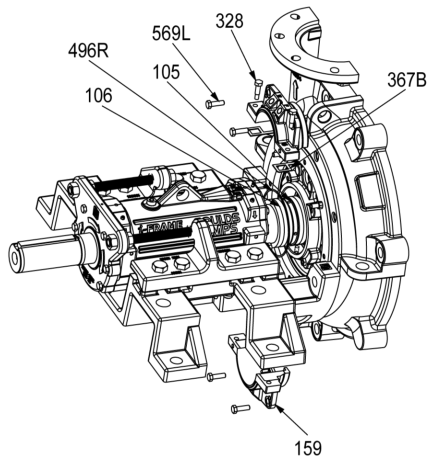

Figure 118: Split Stuffing box installation

6.4.6.7 Install the expeller (optional feature)

1. With the power frame and shaft moved forward so the expeller locating turn is accessible on the shaft; install the expeller (263) onto the shaft (122).
2. Prepare the impeller hub o-ring (412U) with a lubricant and install the o-ring into the o-ring groove on the expeller (263).

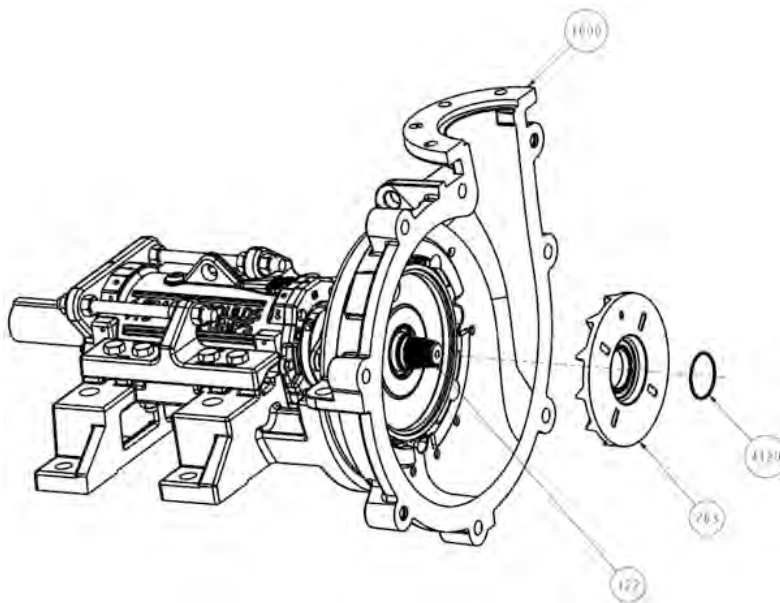

Figure 119: Expeller installation

6.4.6.8 Reassembly for Metal-Lined

The reassembly steps for Metal-lined and Rubber-lined differ. This section, beginning with *Install the casing volute liner* and ending with *Install suction half casing with other suction half components attached*, pertains to Metal-lined pumps.

For Rubber-lined pumps, refer to the sub-section, [6.4.6.14 Reassembly for Rubber-Lined](#) on page 130.

6.4.6.9 Install the casing volute liner - Metal-lined

NOTICE:

When the Dynamic Seal option is provided, be sure the power end and expeller assembly are adjusted prior to volute liner installation so that the expeller does not interfere with the installation of the volute liner.

1. Coat the threads of the casing volute liner retention studs (356K) that will be inserted into the casing volute liner (561) with anti-seize compound.
2. Insert the casing volute liner retention studs into the casing volute liner (561) using a metric stud driver.

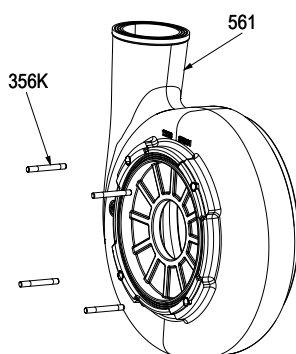

Figure 120: Volute liner stud installation

3. Coat the seal cover-to-volute liner gasket (351Q) with lubricant and install into the casing volute liner (561).
4. Support the casing volute liner (561) using the proper end of the Goulds-provided impeller/casing volute hook tool.
5. Lift the liner into position and insert into the gland half casing (100D) using the installed retention studs (353K) as a guide.

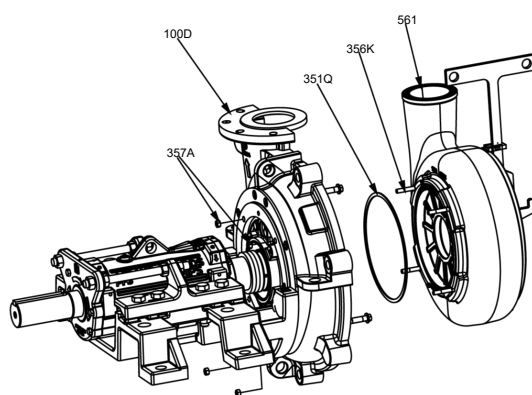

Figure 121: Volute liner installation

6. Secure the casing volute liner (561) to the gland half casing (100D) by installing and fully tightening the volute liner retention hex nuts (355C).

6.4.6.10 Install the impeller - Metal-Lined

Two (2) people should work together to install the impeller for safety purposes.

1. Loosen the adjustment plate bolts (352G) and nuts (427D) but DO NOT remove bolts or adjustment plates (234F). Bolts should remain finger-tightened to keep rotating assembly constrained to the pedestal.
2. Slide the power end forward towards the suction side of the pump to allow better access to the shaft (122) impeller threads.
3. Apply anti-seize compound to the shaft (122) impeller threads.
4. Lift the impeller (101) using a Goulds-provided impeller hook or a chain/sling threaded through a vane passage attached to the hoist.
5. Guide the impeller (101) into position to engage with the shaft impeller threads.
6. With one person holding the impeller steady, the other should turn the shaft (122) clockwise to screw the shaft into the impeller. Begin this operation by hand and finish with an adjustable spanner wrench.

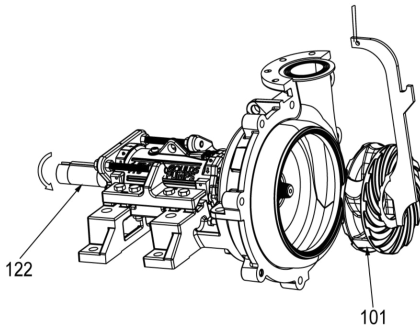

Figure 122: Impeller installation - metal lined

7. After the shaft (122) has been tightly screwed into the impeller (101), the bearing frame can be slid backwards toward the drive end until the impeller sits completely recessed in the casing volute liner (561).
8. Re-secure the bearing frame adjustment plates (234F) by tightening the hold down bolts (352G) and nuts (427D).

6.4.6.11 Suction side assembly

Wet end components on the suction side of the pump need to be assembled to the suction half casing (100A) before they can be attached to the rest of the assembled wet end already mounted on the bearing frame and pedestal.

Pump model	Follow this step
XHD	Install both the suction side liner and adjustable seal ring into the suction half casing before assembling the casing halves. Begin with the Install the adjustable seal ring and suction side liner into the suction half casing step.
XHD Value Option	Attach the suction liner to the suction half casing before assembling the casing halves. Use the Install the suction side liner into the suction half casing step.

6.4.6.12 Install suction side liner into suction half casing - XHD Value Option - Metal-Lined

1. Position the suction side liner (562) inside the suction half casing (100A) so that the tapped holes in the liner are aligned with the thru-holes in the casing.
2. Insert the suction side liner retention studs (356E) through the suction half casing (100A) thru-holes into the threaded holes of the suction side liner (562) and secure with the retention stud nuts (357B).
3. Lubricate and install the volute liner-to-suction side liner gasket (351N).

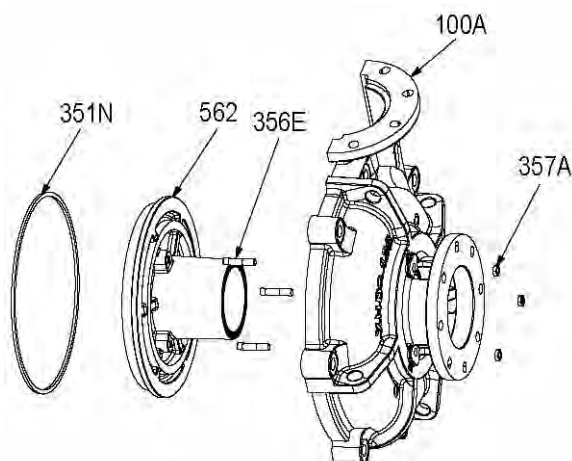

Figure 123: Suction side liner into suction half casing - metal lined

After completion, skip the next step listed for the XHD and move onto the Install the suction half casing step.

6.4.6.13 Install adjustable seal ring and suction side liner into suction half casing - XHD

1. Coat the seal ring ID o-rings (512A) and OD o-rings (512B) with lubricant and install into the adjustable seal ring (822).
2. Install the seal ring indicator roll pin (757A) into the adjustable seal ring (822).
3. Align the three evenly spaced tapped holes in the adjustable seal ring (822) with the three thru-holes of the suction side liner (562).
4. Slide the adjustable seal ring into the suction side liner (562) slowly, keeping the holes aligned while being care not to damage or shear the seal ring OD o-rings (512B).
5. Install the seal ring adjusting bolt onto the adjusting bolts (356F).

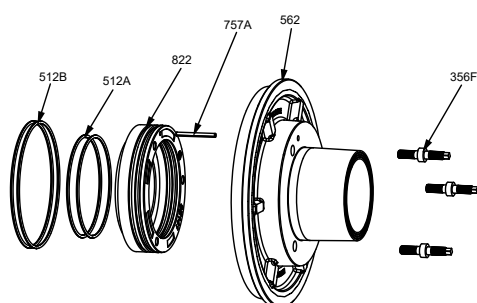

Figure 124: Seal ring installation

6. Coat the non-driving end threads of the square head adjusting bolts (356F) with an anti-seize compound and insert through the suction side liner into the tapped holes of the seal ring.
7. Tighten the square head adjusting bolts (356F) fully using a metric driver. This will fully seat the adjustable seal ring (822) in the suction side liner (562).
8. Using proper support, lift the suction side liner (562) with the adjustable seal ring (822) installed into position and insert into the suction half casing, using the square head adjusting bolts (356F) as a guide.
9. Install the seal ring hex jam nuts (357B) on the square head adjusting bolts (356F) that now protrude from the suction half casing (100A). Fully tighten to complete assembly.

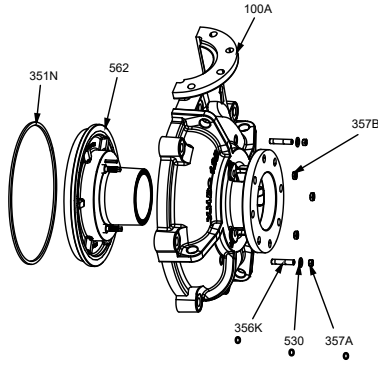

Figure 125: Suction liner installation

10. Coat the volute liner-to-suction side liner flat gasket (351N) with lubricant and install into the suction side liner (561).
11. Install the suction side liner holding threaded rod and nut (372N, sizes 150 and above only).

6.4.6.14 Reassembly for Rubber-Lined

The reassembly steps for Metal-lined and Rubber-lined differ. This section, beginning with *Install the casing volute liner* and ending with *Install suction half casing with other suction half components attached*, pertains to Rubber-lined pumps.

For Metal-lined pumps, refer to the sub-section, [6.4.6.8 Reassembly for Metal-Lined on page 126](#).

6.4.6.15 Install the casing volute liner - Rubber-lined

NOTICE:

When the Dynamic Seal option is provided, be sure the power end and expeller assembly are adjusted prior to volute liner installation so that the expeller does not interfere with the installation of the volute liner.

1. Coat the threads of the casing volute liner retention studs (600L) that will be inserted into the casing volute liner (600T) with anti-seize compound.
2. Insert the provided gland liner retention studs, into the elastomer liner. Tighten the studs by hand being careful to not overtighten as this can damage the liner.

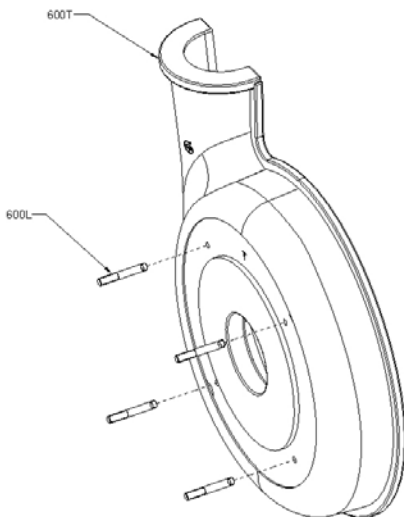
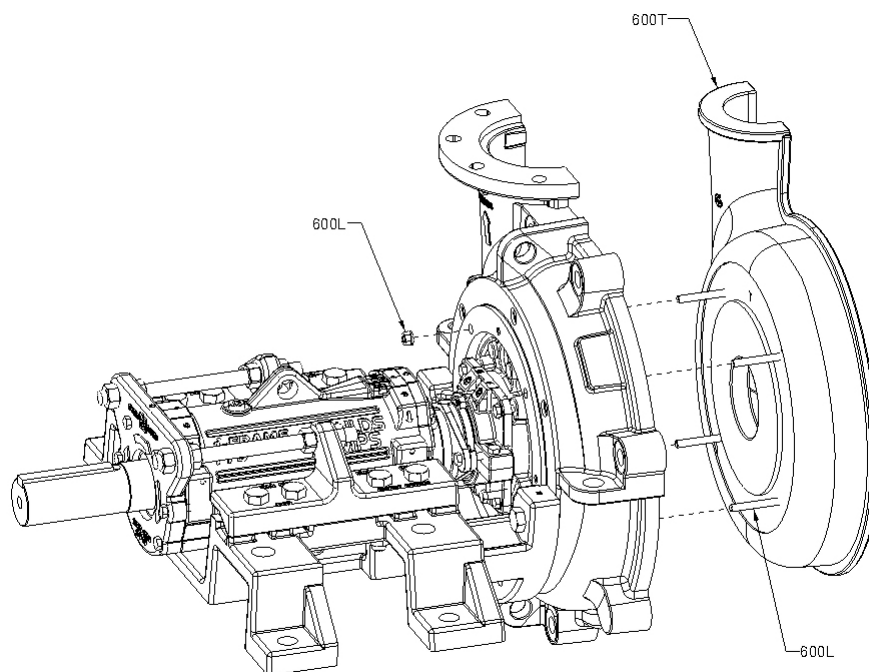

Figure 126: Gland liner stud installation

3. Lift the liner into position and insert into the gland half casing (100D) using the installed retention studs (600L) as a guide.

**Figure 127: Rubber gland liner removal**

4. Secure the casing volute liner (600T) to the gland half casing (100D) by installing and fully tightening the volute liner retention hex nuts (355C).

6.4.6.16 Install the impeller - Rubber-Lined

Two (2) people should work together to install the impeller for safety purposes.

1. Loosen the adjustment plate bolts (352G) and nuts (427D) but DO NOT remove bolts or adjustment plates (234F). Bolts should remain finger-tightened to keep rotating assembly constrained to the pedestal.

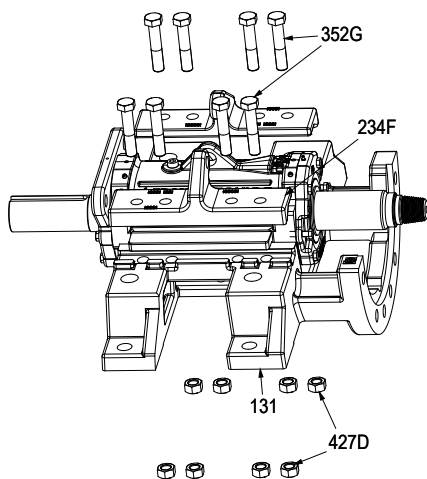
**Figure 128: Adjustment plate bolting installation**

2. Slide the power end forward towards the suction side of the pump to allow better access to the shaft (122) impeller threads.
3. Apply anti-seize compound to the shaft (122) impeller threads.
4. Lift the impeller (101) using a strap or a chain/sling threaded through a vane passage attached to the hoist.
5. Guide the impeller (101) into position to engage with the shaft impeller threads.
6. With one person holding the impeller steady, the other should turn the shaft (122) clockwise to screw the shaft into the impeller. Begin this operation by hand and finish with an adjustable spanner wrench.

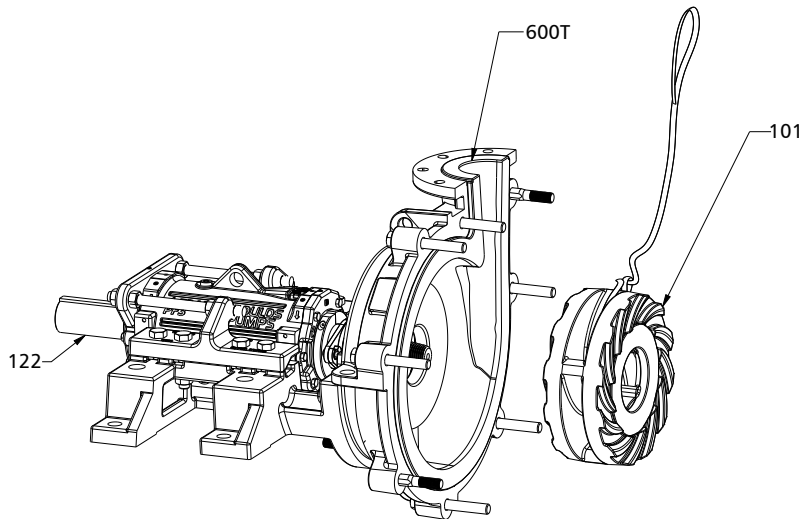

Figure 129: Impeller installation

7. After the shaft (122) has been tightly screwed into the impeller (101), the bearing frame can be slid backwards toward the drive end until the impeller sits completely recessed in the casing volute liner (600T).
8. Re-secure the bearing frame adjustment plates (234F) by tightening the hold down bolts (352G) and nuts (427D).

6.4.6.17 Install suction side liner into suction half casing - Rubber-Lined

1. Position the suction side liner (600R) inside the suction half casing (100A) so that the tapped holes in the liner are aligned with the thru-holes in the casing.
2. Insert the suction side liner retention studs (600L) through the suction half casing (100A) thru-holes into the threaded holes of the suction side liner (600R) and secure with the retention stud nuts (600N).

6.4.6.18 Install suction half casing with other suction half components attached - Rubber-lined

During assembly, the casing bolts are typically inserted from the gland side of the wet end. This methodology can ease installation and tightening of flat washers and hex nuts when completing assembly of the suction and gland halves of the wet end.

1. Install the tapered alignment studs (600D) into the gland half casing (100D) in the locations shown.
2. Attach the hoist hook to the suction half casing (100A) lifting lug.
3. Lift the suction half casing (with other installed components) into place and move forward until the casing halves are flush, using the tapered alignment studs (600D) as a guide.
4. Install the flat washers (533) and tapered stud hex nuts (415B) on the forward face of the suction half casing (100A).

5. Insert the casing bolts (600A) into the remaining casing holes.
6. Install the flat washers (553) and casing bolt hex nuts (600C) onto the casing bolts (600A) to complete assembly of the casing halves.

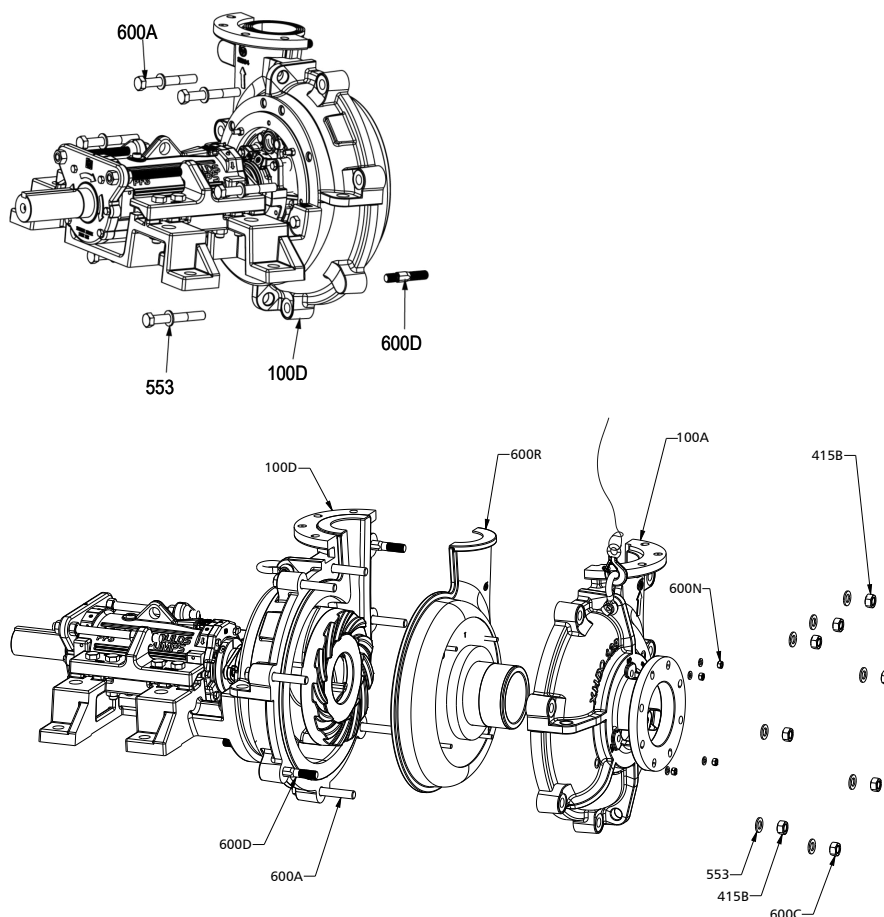

Figure 130: Installation of suction half casing with attached components - rubber lined

6.4.6.19 Install packing, lantern ring, and gland

1. Measure the appropriate length of packing (106) strips by wrapping packing around the shaft sleeve (126) to estimate the desired length. Carefully cut each strip that is needed $\frac{1}{4}$ " shorter than circumference of the shaft sleeve.
2. Install packing (106) and lantern ring (105) in the appropriate order that based upon the service dilution requirements. See the Maintenance – Packing section for details.
3. Position the two halves of the gland assembly (107) around the shaft sleeve (126). Assemble the gland assembly (107) and attach to the stuffing box using the gland adjusting bolts (353).

6.4.6.20 Install the flanges and joint gaskets

1. Install the two-piece suction and discharge flanges (195C, sizes 150 and above only).
2. Install the discharge joint flat gasket (351A).
3. Install the suction joint flat gasket (351B).

NOTICE:

Flange gaskets 351A and 351B are supplied only with metal lined assemblies.

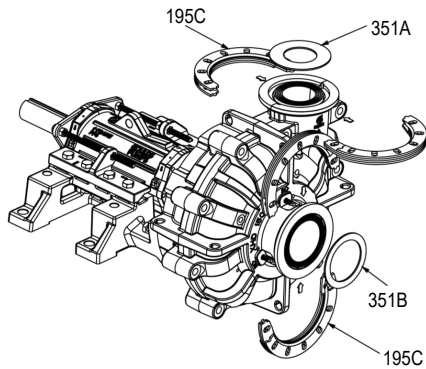

Figure 131: Installation of flanges and joint gaskets

6.4.7 Assembly references

6.4.7.1 Spare parts

Recommended spare parts

In order to prevent a long and costly downtime period, especially on critical services, it is advisable that you have these spare parts on hand:

- Casing volute liner (561)
- Casing gland liner (600T) - Rubber-lined
- Suction side liner (562) - Metal-lined
- Suction side liner (600R) - Rubber-lined
- Suction side liner holding rod and nut (372N, sizes 150 and above only)
- Adjustable seal ring (822, XHD only)
- Adjustable seal ring hardware (XHD only)
 - Square head adjusting bolts (356F)
 - Seal ring adjusting bolt o-rings (512C)
 - Seal ring jam nuts (357B)
 - Seal ring inner diameter o-rings (512A)
 - Seal ring outer diameter o-rings (512B)
- Suction and discharge flanges (196C, sizes 150 and above)
- Impeller (101)
- Impeller hub o-ring (412A) - Metal-lined only
- Shaft sleeve (126)
- Lantern ring (105, packed pump only)
- Gaskets - Metal-lined only
 - Suction joint flat gasket (351A)
 - Discharge joint flat gasket (351B)
 - Casing volute liner to suction side liner flat gasket (351N, XHD only)
- Inboard taper roller bearing (409)
- Outboard taper roller bearing (410)
- Shaft (122)
- Spacer sleeve o-ring (512D)

- Inboard and outboard bearing cover o-rings (412)

6.4.7.2 Bearing bore fits and tolerances

Group	Bearing	Maximum bearing frame bore in millimeters inches
PF1	Inboard	110.037 4.3322
	Outboard	
PF2	Inboard	130.040 5.1197
	Outboard	
PF3	Inboard	190.046 7.4821
	Outboard	
PF4S	Inboard	200.050 7.8760
	Outboard	
PF4	Inboard	260.052 10.2383
	Outboard	
PF5	Inboard	290.052 11.4193
	Outboard	

6.4.7.3 Bolt torques for XHD50 / PF1

Option	Item number	Description	Thread size	Torque (N-m) Lubricated (k=.10)	Torque (ft-lbs) Lubricated (k=.10)
Standard	600A	Hex bolt, casing	M16x2	110	81
Standard	600C	Hex nut, casing			
Standard	600D	Taper stud, casing alignment	M16x2	110	81
Standard	415B	Hex nut, taper stud			
Standard	356K	Stud, volute liner retention	M10x1.5	25	19
Standard	357A	Hex nut, volute liner retention			
Standard	356E	Stud, suction side liner	M12x1.5	25	19
Standard	357J	Hex nut, suction side liner			
Standard	388A	Screw, socket head (seal cover retention)	M6x1	5	4
Split box	328	Screw socket head	M10x1.5	44	33
Split box	596L	Hex head cap screw, chamber to cover	M12x1.75	44	33
Standard	353	Bolt, gland adjusting			
Standard	352G	Hex cap screw, plate	M16x2	110	81
Standard	427D	Hex nut, plate to pedestal			
Standard	370X	Threaded rod, housing adjustment	M20x2.5	221	164
Standard	415A	Hex nut, threaded rod			
Standard	375B	Taper stud, pedestal to gland half casing	M16x2	110	81
Standard	427L	Hex nut, taper stud (pedestal to gland half casing)			
Standard	370Y	Hex cap screw, pedestal to gland half casing	M16x2	110	81
Standard	370N	Hex head cap screw, outboard bearing cover	M8x1.25	13	10
Standard	370P	Hex cap screw, inboard bearing cover			
Standard	791B	Bolt, shoulder (chamber, split packing)	M5x.8	3	2

6.4.7.4 Bolt torques for XHD75 / PF1

Option	Item number	Description	Thread size	Torque (N-m) Lubricated (k=.10)	Torque (ft-lbs) Lubricated (k=.10)
Standard	600A	Hex bolt, casing	M20x2.5	221	164
Standard	600C	Hex nut, casing			
Standard	600D	Taper stud, casing alignment	M20x2.5	221	164
Standard	415B	Hex nut, taper stud			
Standard	356K	Stud, volute liner retention	M10x1.5	25	19
Standard	357A	Hex nut, volute liner retention			
Standard	356E	Stud, suction side liner	M10x1.5	25	19
Standard	357J	Hex nut, suction side liner			
Standard	388A	Screw, socket head (seal cover retention)	M6x1	5	4
Split box	328	Screw socket head	M10x1.5	25	19
Split box	596L	Hex head cap screw, chamber to cover	M12x1.75	44	33
Standard	353	Bolt, gland adjusting			
Standard	352G	Hex cap screw, plate	M16x2	110	81
Standard	427D	Hex nut, plate to pedestal			
Standard	370X	Threaded rod, housing adjustment	M20x2.5	221	164
Standard	415A	Hex nut, threaded rod			
Standard	375B	Taper stud, pedestal to gland half casing	M16x2	110	81
Standard	427L	Hex nut, taper stud (pedestal to gland half casing)			
Standard	370Y	Hex cap screw, pedestal to gland half casing	M16x2	110	81
Standard	370N	Hex head cap screw, outboard bearing cover	M8x1.25	13	10
Standard	370P	Hex cap screw, inboard bearing cover			
Standard	791B	Bolt, shoulder (chamber, split packing)	M5x.8	3	2

6.4.7.5 Bolt torques for XHD80

Option	Item number	Description	Thread size	Torque (N-m) Lubricated (k=.10)	Torque (ft-lbs) Lubricated (k=.10)
Standard	600A	Hex bolt, casing	M20x2.5	221	164
Standard	600C	Hex nut, casing			
Standard	600D	Taper stud, casing alignment	M20x2.5	221	164
Standard	415B	Hex nut, taper stud			
Standard	356K	Stud, volute liner retention	M10x1.5	25	19
Standard	357A	Hex nut, volute liner retention			
Standard	356E	Stud, suction side liner	M12x1.75	44	33
Standard	357J	Hex nut, suction side liner			
Standard	356F	Adjusting bolt, square head (seal ring)	M12x1.75	44	33
Standard	357B	Hex nut, jam (seal ring)			
Standard	388A	Screw, socket head (seal cover retention)	M6x1	5	4
Split box	328	Screw socket head	M10x1.5	44	33
Split box	596L	Hex head cap screw, chamber to cover	M12x1.75	44	33

Option	Item number	Description	Thread size	Torque (N-m) Lubricated (k=.10)	Torque (ft-lbs) Lubricated (k=.10)
Standard	353	Bolt, gland adjusting			
Standard	352G	Hex cap screw, plate	M16x2	110	81
Standard	427D	Hex nut, plate to pedestal			
Standard	370X	Threaded rod, housing adjustment	M20x2.5	221	164
Standard	415A	Hex nut, threaded rod			
Standard	375B	Taper stud, pedestal to gland half casing	M16x2	110	81
Standard	427L	Hex nut, taper stud (pedestal to gland half casing)			
Standard	370Y	Hex cap screw, pedestal to gland half casing	M16x2	110	81
Standard	370N	Hex head cap screw, outboard bearing cover	M8x1.25	13	10
Standard	370P	Hex cap screw, inboard bearing cover			
Standard	791B	Bolt, shoulder (chamber, split packing)	M5x.8	3	2

6.4.7.6 Bolt torques for XHD100 and XHD125

Option	Item number	Description	Thread size	Torque (N-m) Lubricated (k=.10)	Torque (ft-lbs) Lubricated (k=.10)
Standard	600A	Hex bolt, casing	M24x3	381	282
Standard	600C	Hex nut, casing			
Standard	600D	Taper stud, casing alignment	M24x3	381	282
Standard	415B	Hex nut, taper stud			
Standard	356K	Stud, volute liner retention	M12x1.75	44	33
Standard	357A	Hex nut, volute liner retention			
Standard	356E	Stud, suction side liner	M16x2	110	81
Standard	357J	Hex nut, suction side liner			
Standard	356F	Adjusting bolt, square head (seal ring)	M16x2	110	81
Standard	357B	Hex nut, jam (seal ring)			
Standard	388A	Screw, socket head (seal cover retention)	M8x1.25	13	10
Split box	328	Screw socket head	M10x1.5	25	19
Split box	596L	Hex head cap screw, chamber to cover	M12x1.75	44	33
Standard	353	Bolt, glad adjusting			
Standard	352G	Hex cap screw, plate	M24x3	381	282
Standard	427D	Hex nut, plate to pedestal			
Standard	370X	Threaded rod, housing adjustment	M24x3	381	282
Standard	415A	Hex nut, threaded rod			
Standard	375B	Taper stud, pedestal to gland half casing	M24x3	381	282
Standard	427L	Hex nut, taper stud (pedestal to gland half casing)			
Standard	370Y	Hex cap screw, pedestal to gland half casing	M24x3	381	282
Standard	370N	Hex head cap screw, outboard bearing cover	M12x1.75	44	33
Standard	370P	Hex cap screw, inboard bearing cover			
Standard	791B	Bolt, shoulder (chamber, split packing)	M10x1.5	25	19

6.4.7.7 Bolt torques for XHD150

Option	Item number	Description	Thread size	Torque (N-m) Lubricated (k=.10)	Torque (ft-lbs) Lubricated (k=.10)
Standard	600A	Hex bolt, casing	M30x3.5	758	561
Standard	600C	Hex nut, casing			
Standard	600D	Taper stud, casing alignment	M30x3.5	758	561
Standard	415B	Hex nut, taper stud			
Standard	356K	Stud, volute liner retention	M16x2	110	81
Standard	357A	Hex nut, volute liner retention			
Standard	356E	Stud, suction side liner	M20x2.5	110	81
Standard	357J	Hex nut, suction side liner			
Standard	356F	Adjusting bolt, square head (seal ring)	M20x2.5	221	164
Standard	357B	Hex nut, jam (seal ring)			
Standard	388A	Screw, socket head (seal cover retention)	M10x1.5	25	19
Split box	328	Screw socket head	M12x1.75	44	33
Split box	596L	Hex head cap screw, chamber to cover	M16x2	110	81
Standard	353	Bolt, glad adjusting			
Standard	352G	Hex cap screw, plate			
Standard	427D	Hex nut, plate to pedestal	M30x3.5	758	561
Standard	370X	Threaded rod, housing adjustment	M24x3	381	282
Standard	415A	Hex nut, threaded rod			
Standard	375B	Taper stud, pedestal to gland half casing	M30x3.5	758	561
Standard	427L	Hex nut, taper stud (pedestal to gland half casing)			
Standard	370Y	Hex cap screw, pedestal to gland half casing	M30x3.5	758	561
Standard	370N	Hex head cap screw, outboard bearing cover	M16x2	110	81
Standard	370P	Hex cap screw, inboard bearing cover			
Standard	791B	Bolt, shoulder (chamber, split packing)	M10 x1.5	25	19

6.4.7.8 Bolt torques for XHD200

Option	Item number	Description	Thread size	Torque (N-m) Lubricated (k=.10)	Torque (ft-lbs) Lubricated (k=.10)
Standard	600A	Hex bolt, casing	M36x4	1324	980
Standard	600C	Hex nut, casing			
Standard	600D	Taper stud, casing alignment	M36x4	1324	980
Standard	415B	Hex nut, taper stud			
Standard	356K	Stud, volute liner retention	M16x2	110	81
Standard	357A	Hex nut, volute liner retention			
Standard	356E	Stud, suction side liner	M20x2.5	110	81
Standard	357J	Hex nut, suction side liner			
Standard	356F	Adjusting bolt, square head (seal ring)	M20x2.5	221	164
Standard	357B	Hex nut, jam (seal ring)			

Option	Item number	Description	Thread size	Torque (N-m) Lubricated (k=.10)	Torque (ft-lbs) Lubricated (k=.10)
Standard	388A	Screw, socket head (seal cover retention)	M10x1.5	25	19
Split box	328	Screw socket head	M12x1.75	44	33
Split box	596L	Hex head cap screw, chamber to cover	M16x2	110	81
Standard	353	Bolt, glad adjusting			
Standard	352G	Hex cap screw, plate	M30x3.5	758	561
Standard	427D	Hex nut, plate to pedestal			
Standard	370X	Threaded rod, housing adjustment	M24x3	381	282
Standard	415A	Hex nut, threaded rod			
Standard	375B	Taper stud, pedestal to gland half casing	M30x3.5	758	561
Standard	427L	Hex nut, taper stud (pedestal to gland half casing)			
Standard	370Y	Hex cap screw, pedestal to gland half casing	M30x3.5	110	81
Standard	370N	Hex head cap screw, outboard bearing cover	M16x2	110	81
Standard	370P	Hex cap screw, inboard bearing cover			
Standard	791B	Bolt, shoulder (chamber, split packing)	M10	625	19

6.4.7.9 Bolt Torques for XHD250

Option	Item number	Description	Thread size	Torque (N-m) Lubricated (k=.10)	Torque (ft-lbs) Lubricated (k=.10)
Standard	600A	Hex bolt, casing	M42x4.5	2117	1567
Standard	600C	Hex nut, casing			
Standard	600D	Taper stud, casing alignment	M42x4.5	2117	1567
Standard	415B	Hex nut, taper stud			
Standard	356K	Stud, volute liner retention	M20x2.5	221	164
Standard	357A	Hex nut, volute liner retention			
Standard	356E	Stud, suction side liner	M20x2.5	221	164
Standard	357J	Hex nut, suction side liner			
Standard	356F	Adjusting bolt, square head (seal ring)	M24x3	381	282
Standard	357B	Hex nut, jam (seal ring)			
Standard	388A	Screw, socket head (seal cover retention)	M10x1.5	25	19
Split box	328	Screw socket head	M16x2	110	81
Split box	596L	Hex head cap screw, chamber to cover	M20x2.5	221	164
Standard	353	Bolt, glad adjusting			
Standard	352G	Hex cap screw, plate	M36x4	1324	980
Standard	427D	Hex nut, plate to pedestal			
Standard	370X	Threaded rod, housing adjustment	M24x3	381	282
Standard	415A	Hex nut, threaded rod			
Standard	375B	Taper stud, pedestal to gland half casing	M36x4	1324	980
Standard	427L	Hex nut, taper stud (pedestal to gland half casing)			
Standard	370Y	Hex cap screw, pedestal to gland half casing	M30x3.5	758	561

Option	Item number	Description	Thread size	Torque (N-m) Lubricated (k=.10)	Torque (ft-lbs) Lubricated (k=.10)
Standard	370N	Hex head cap screw, outboard bearing cover	M16x2	110	81
Standard	370P	Hex cap screw, inboard bearing cover			
Standard	791B	Bolt, shoulder (chamber, split packing)	M12	44	33

6.4.7.10 Bolt torques for XHD300

Option	Item number	Description	Thread size	Torque (N-m) Lubricated (k=.10)	Torque (ft-lbs) Lubricated (k=.10)
Standard	600A	Hex bolt, casing	M48x5	3175	2350
Standard	600C	Hex nut, casing			
Standard	600D	Taper stud, casing alignment	M48x5	3175	2350
Standard	415B	Hex nut, taper stud			
Standard	356K	Stud, volute liner retention	M20x2.5	221	164
Standard	357A	Hex nut, volute liner retention			
Standard	356E	Stud, suction side liner	M20x2.5	221	164
Standard	357J	Hex nut, suction side liner			
Standard	356F	Adjusting bolt, square head (seal ring)	M24x3	381	282
Standard	357B	Hex nut, jam (seal ring)			
Standard	388A	Screw, socket head (seal cover retention)	M10x1.5	25	19
Split box	328	Screw socket head	M16x2	110	81
Split box	596L	Hex head cap screw, chamber to cover	M20x2.5	221	164
Standard	353	Bolt, gland adjusting			
Standard	352G	Hex cap screw, plate	M36x4	1324	980
Standard	427D	Hex nut, plate to pedestal	M36x4	1324	980
Standard	370X	Threaded rod, housing adjustment	M24x3	381	282
Standard	415A	Hex nut, threaded rod			
Standard	375B	Taper stud, pedestal to gland half casing	M36x4	1324	980
Standard	427L	Hex nut, taper stud (pedestal to gland half casing)			
Standard	370Y	Hex cap screw, pedestal to gland half casing	M30x3.5	758	561
Standard	370N	Hex head cap screw, outboard bearing cover	M16x2	110	81
Standard	370P	Hex cap screw, inboard bearing cover			
Standard	791B	Bolt, shoulder (chamber, split packing)	M12	44	33

6.4.8 Install the shaft guard



WARNING:

- Running a pump without safety devices exposes operators to risk of serious personal injury or death. Never operate a unit unless appropriate safety devices (guards, etc.) are properly installed.

- Failure to disconnect and lock out driver power may result in serious physical injury or death. Always disconnect and lock out power to the driver before performing any installation or maintenance tasks.
 - Electrical connections must be made by certified electricians in compliance with all international, national, state, and local rules.
- Exposed rotating shaft between pump seal and bearing frame. Avoid contact and/or install proper guarding. If guarding is not provided with the pump, contact Goulds for price and availability of proper guarding.

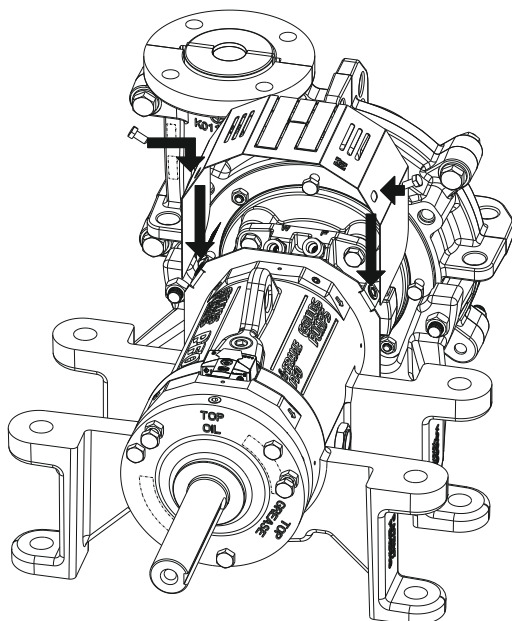

1. Ensure that the mounting bolt for each shaft guard half is inserted with the bolt retainer in place for captive hardware.
2. Assemble a guard half from each side of the pump and fasten to the bearing frame.
3. Ensure that adequate coverage is maintained for rotating components.

7 Troubleshooting

7.1 Operation troubleshooting

Symptom	Cause	Remedy
The pump is not delivering liquid.	The pump is not primed.	Re-prime the pump and check that the pump and suction line are full of liquid.
	The suction line is clogged.	Remove the obstructions.
	The impeller is clogged.	Back-flush the pump in order to clean the impeller.
	The shaft is rotating in the wrong direction.	Change the rotation. The rotation must match the arrow on the bearing housing or pump casing.
	The foot valve or suction pipe opening is not submerged enough.	Consult an ITT representative for the proper submersion depth. Use a baffle in order to eliminate vortices.
	The suction lift is too high.	Shorten the suction pipe.
The pump is not producing the rated flow or head.	The gasket or O-ring has an air leak.	Replace the gasket or O-ring.
	The stuffing box has an air leak.	Replace or readjust the mechanical seal.
	The impeller is partly clogged.	Back-flush the pump in order to clean the impeller.
	The clearance between the impeller and the pump casing is excessive.	Adjust the impeller clearance.
	The suction head is not sufficient.	Make sure that the suction-line shutoff valve is fully open and that the line is unobstructed.
	The impeller is worn or broken.	Inspect and replace the impeller if necessary.
The pump starts and then stops pumping.	The pump is not primed.	Re-prime the pump and check that the pump and suction line are full of liquid.
	The suction line has air or vapor pockets.	Rearrange the piping in order to eliminate air pockets.
	The suction line has an air leak.	Repair the leak.
The bearings are running hot.	The pump and driver are not aligned properly.	Realign the pump and driver.
	There is not sufficient lubrication.	Check the lubricant for suitability and level.
	The lubrication was not cooled properly.	Check the cooling system.
The pump is noisy or vibrates.	The pump and driver are not aligned properly.	Realign the pump and driver.
	The impeller is partly clogged.	Back-flush the pump in order to clean the impeller.
	The impeller or shaft is broken or bent.	Replace the impeller or shaft as necessary.
	The foundation is not rigid.	Tighten the hold-down bolts of the pump and motor. Make sure the baseplate is properly grouted without voids or air pockets.
	The bearings are worn.	Replace the bearings.
	The suction or discharge piping is not anchored or properly supported.	Anchor the suction or discharge piping as necessary according to recommendations in the Hydraulic Institute Standards Manual.
	The pump is cavitating.	Locate and correct the system problem.
The mechanical seal is leaking excessively.	The packing gland is not adjusted properly.	Tighten the gland nuts.

Symptom	Cause	Remedy
	The stuffing box is not packed properly.	Check the packing and repack the box.
	The mechanical seal parts are worn.	Replace the worn parts.
	The mechanical seal is overheating.	Check the lubrication and cooling lines.
	The shaft or shaft sleeve is scored.	Machine or replace the shaft sleeve as necessary.
The motor requires excessive power.	The discharge head has dropped below the rated point and is pumping too much liquid.	Install a throttle valve. If this does not help, then trim the impeller diameter. If this does not help, then contact your ITT representative.
	The liquid is heavier than expected.	Check the specific gravity and viscosity.
	The stuffing-box packing is too tight.	Readjust the packing. If the packing is worn, then replace the packing.
	Rotating parts are rubbing against each other.	Check the parts that are wearing for proper clearances.
	The impeller clearance is too tight.	Adjust the impeller clearance.

7.2 Alignment troubleshooting

Symptom	Cause	Remedy
Horizontal (side-to-side) alignment cannot be obtained (angular or parallel).	The driver feet are bolt-bound.	Loosen the pump's hold-down bolts, and slide the pump and driver until you achieve horizontal alignment.
	The baseplate is not leveled properly and is probably twisted.	<ol style="list-style-type: none"> Determine which corners of the baseplate are high or low. Remove or add shims at the appropriate corners. Realign the pump and driver.
Vertical (top-to-bottom) alignment cannot be obtained (angular or parallel).	The baseplate is not leveled properly and is probably bowed.	<ol style="list-style-type: none"> Determine if the center of the baseplate should be raised or lowered. Level screws equally at the center of the baseplate. Realign the pump and driver.

7.3 Assembly troubleshooting

Table 16: Troubleshooting procedure

Symptom	Cause	Remedy
There is excessive shaft end play.	The internal clearance of the bearings is excessive.	Replace the bearings with a bearing of the correct type.
	The thrust-bearing end cover is loose.	Tighten the screws.
	There are too many shims under the thrust bearing end cover.	Remove the individual shims to obtain the proper thickness.
The runout for the shaft is excessive.	The shaft is bent.	Replace the shaft.
The runout for the bearing-frame flange is excessive.	The shaft is bent.	Replace the shaft.
	The flange of the bearing frame is distorted.	Replace the bearing-frame flange.
The runout for the seal-chamber cover is excessive.	The seal-chamber cover is improperly seated on the frame.	Replace or re-machine the seal-chamber cover.
	There is corrosion or wear on the seal-chamber cover.	Replace the seal-chamber cover.

7.3 Assembly troubleshooting

Symptom	Cause	Remedy
The runout for the impeller wear ring is excessive.	The shaft is bent.	Replace the shaft.
	The wear ring was machined improperly.	Replace or re-machine the impeller.

8 Parts List and Cross-Sectionals

8.1 Assembly drawings - (exploded views)

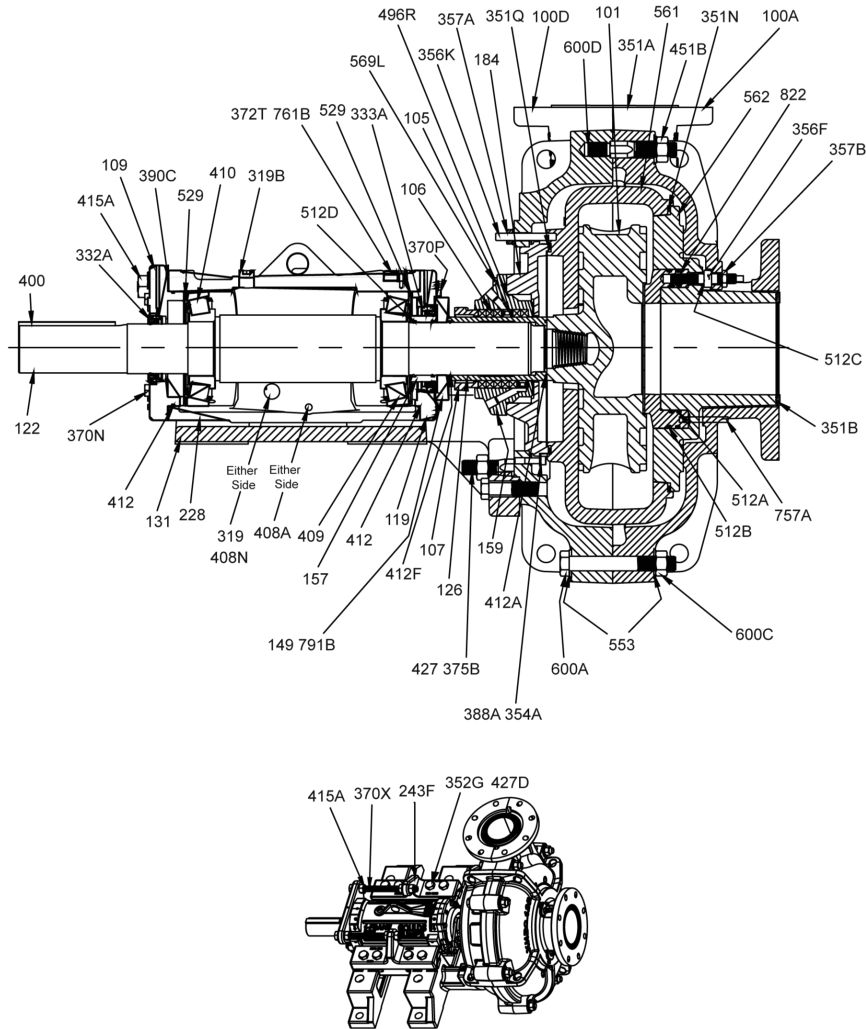

Figure 132: XHD Standard oil lubrication - Metal-lined

8.1 Assembly drawings - (exploded views)

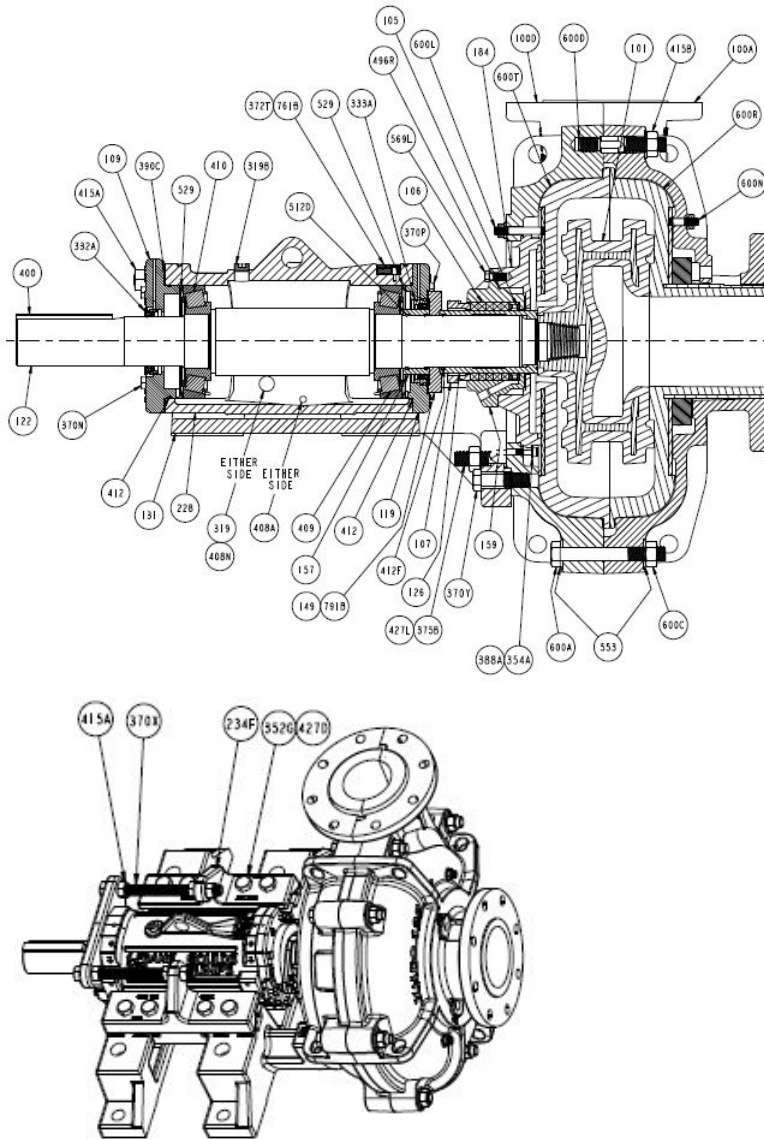

Figure 133: XHD Standard oil lubrication - Rubber-lined

Item	Description	High Chrome HC600	High Chrome w/DI Seal Cover HC600/DI	Endura-Chrome Special HC	Ultra High Chrome 35% Cr	CD4MCu-NA890 Gr.1B	Elastomers See Rubber-lined Table
100A	Suction half casing				1018		
100D	Gland half casing				1018		
101	Impeller		1228	1269	1650	1216	see Rubber-lined Table
105	Lantern ring				6308		
106	Packing				5026		
107	Gland half				1203		
109	Bearing cover, out-board				1018		
113	Fitting, grease relief				-		

Item	Description	High Chrome HC600	High Chrome w/DI Seal Cover HC600/DI	Endura-Chrome Special HC	Ultra High Chrome 35% Cr	CD4MCu-NA890 Gr.1B	Elastomers See Rubber-lined Table
119	Bearing cover, in-board	1018					
122	Shaft	2251					
126	Sleeve, shaft	2222			1216	1216	2222
131	Pedestal	1018					
149	Ring, knockoff	1203					
157	Sleeve, spacer	1203					
159	Chamber, split packing assembly	1018			1216	1216	1018/Alloy
184	Cover, seal	1228	1018	1269	1216	1216	1228/Alloy
193B	Fitting, grease	-					
193L	Fitting, grease (bearing covers)	-					
195C	Flange, split	Carbon Steel					
228	Frame, bearing	1018					
234F	Plate, bearing frame adjustment	1018					
263	Expeller	1228		1269	NA	1216	1228
297B	Rupture disc assembly						
319	Sight glass	-					
319B	Plug, pipe (oil fill)	2472					
319H	Plug, pipe (grease fittings, frame)	2472					
327U	Screw, Hex Cap (shaft guard)	2472					
328	Bolt, hex shoulder	2473					
332A	Seal, outboard	-					
333A	Seal, inboard	-					
346A	Shield, grease	3201					
351A	Gasket, discharge	5206 (Metal Lined Only)					
351B	Gasket, suction	5206 (Metal Lined Only)					
351N	Gasket, volute liner to suction side liner	5206 (Metal Lined Only)					
351Q	Gasket, seal cover to volute liner	5211 for 50, 75, 80, 5206 for all other sizes (Metal Lined Only)					
352G	Screw, hex cap (plate)	2472					
352H	Screw, hex cap (rupture disc)	2472					
353	Screw, hex cap (gland adjusting)	2472					
354A	Washer, clipped (seal cover retention)	5429					
356E	Stud, suction side liner	2472 (Metal Lined Only)					

8.1 Assembly drawings - (exploded views)

Item	Description	High Chrome HC600	High Chrome w/DI Seal Cover HC600/DI	Endura-Chrome Special HC	Ultra High Chrome 35% Cr	CD4MCu-NA890 Gr.1B	Elastomers See Rubber-lined Table
356F	Adjusting bolt, square head (seal ring)	2472					
356K	Stud, suction side liner	2472 (Metal Lined Only)					
357A	Nut, hex (volute liner retention)	2472 (Metal Lined Only)					
357B	Nut, hex jam (seal ring)	2472 (Metal Lined Only)					
357J	Nut, hex (suction side liner)	2472 (Metal Lined Only)					
358B	Plug, pipe (chamber)	2472					
367B	Gasket, chamber	5145					
367B	Gasket, chamber	5145					
370N	Screw, hex cap (outboard bearing cover)	2472					
370P	Screw, hex cap (inboard bearing cover)	2472					
370Y	Screw, hex cap (pedestal to gland half casing)	2472					
370W	Screw, hex cap (inboard bearing cover)	2472					
370X	Threaded rod, frame adjustment	2472					
372T	Screw, i-Alert	2367					
375B	Taper stud, pedestal to gland half casing	2472					
388A	Screw, socket head (seal cover retention)	2472					
390C	Shim pack (outboard bearing cover)	non-metallic					
400	Key, shaft	2213					
408A	Plug, pipe (oil drain)	2472					
408N	Plug, pipe (opposite sight glass)	2472					
409	Taper roller bearing, inboard	-					
410	Taper roller bearing, outboard	-					
412	O-ring, inboard bearing cover	5302					
412	O-ring, outboard bearing cover	5302					
412A	O-ring, impeller hub	5302					
412F	O-ring, shaft sleeve	5302					
414C	Screw, tapping (splash guard)	2472					

Item	Description	High Chrome HC600	High Chrome w/DI Seal Cover HC600/DI	Endura-Chrome Special HC	Ultra High Chrome 35% Cr	CD4MCu-NA890 Gr.1B	Elastomers See Rubber-lined Table
415A	Nut, hex (threaded rods)	2472					
415B	Nut, hex (taper stud, casing alignment)	2472					
427D	Nut, hex (plate to pedestal)	2472					
496R	O-ring, chamber	5302					
501D	Guard, cover	3201					
501M	Guard, adjustable shaft (frame end)	3201					
501N	Guard, adjustable shaft (gland end)	3201					
512B	O-ring, seal ring OD	5302					
512A	O-ring, seal ring ID	5302					
512C	O-ring, adjusting bolt (seal ring)	5302					
512D	O-ring, spacer sleeve	5302					
529	Bellville washer	1392					
530	Washer, plan (suction side liner)	5429					
553	Washer, plain (casing)	5429					
561	Volute liner, casing	1228		1269	1650	1216	NA
562	Suction side liner	1228		1269	1650	1216	See Rubber-lined Table
569L	Screw, hex cap (casing)	2472					
600A	Screw, hex cap (casing)	2472					
600C	Nut, hex (casing)	2472					
600D	Taper stud, casing alignment	2472					
757A	Roll pin, seal ring indicator	5429					
761B	i-Alert, conditional monitor	-					
791B	Bolt, shoulder (knock-off ring)	2473					
791Z	Lifting hook	-					
822	Seal ring	1228		1269	1650	1216	See Rubber-lined Table

Table 17: Materials of Construction - Rubber-lined

Item	Part Description	Natural black rubber	Nitrile/Chemigum	Chlorobutyl	Neoprene
		(40A)	(60A)	(55A)	(60A)
		6898	6894	6892	6896
101	Impeller	6898*	6894*	6892*	6896*

8.1 Assembly drawings - (exploded views)

Item	Part Description	Natural black rubber	Nitrile/Chemigum	Chlorobutyl	Neoprene
		(40A)	(60A)	(55A)	(60A)
		6898	6894	6892	6896
184	Cover, Seal	1228*			
263	Expeller	1228*			
600R	Suction Volute Rubber Liner	6898	6894	6892	6896
600T	Gland Volute Rubber Liner				
600S	Suction Wear Plate				
822	Seal Ring	RTF			

* Other materials available including 1228/1269/1216/1650 depending on Elastomer selected and application

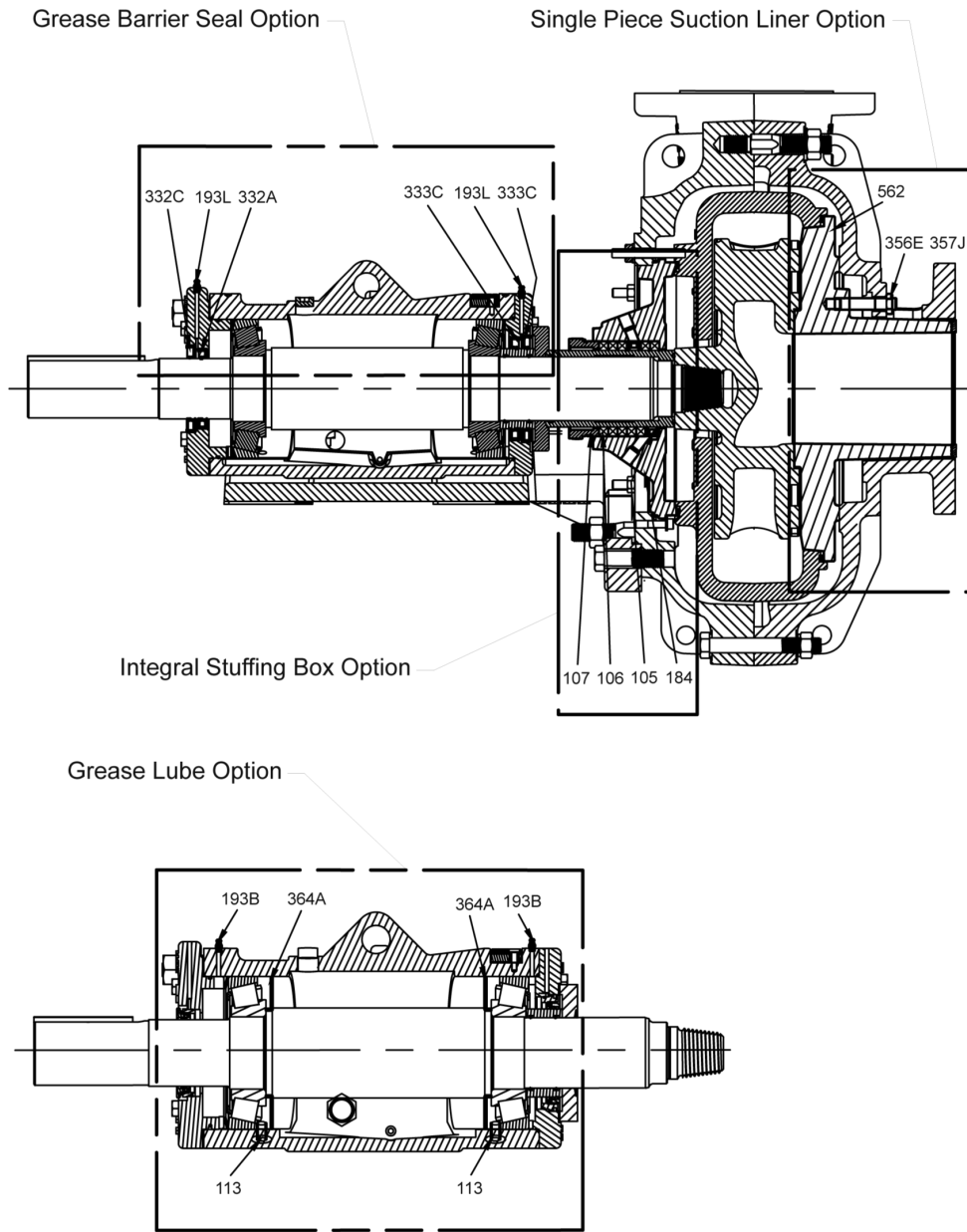

Figure 134: Optional features

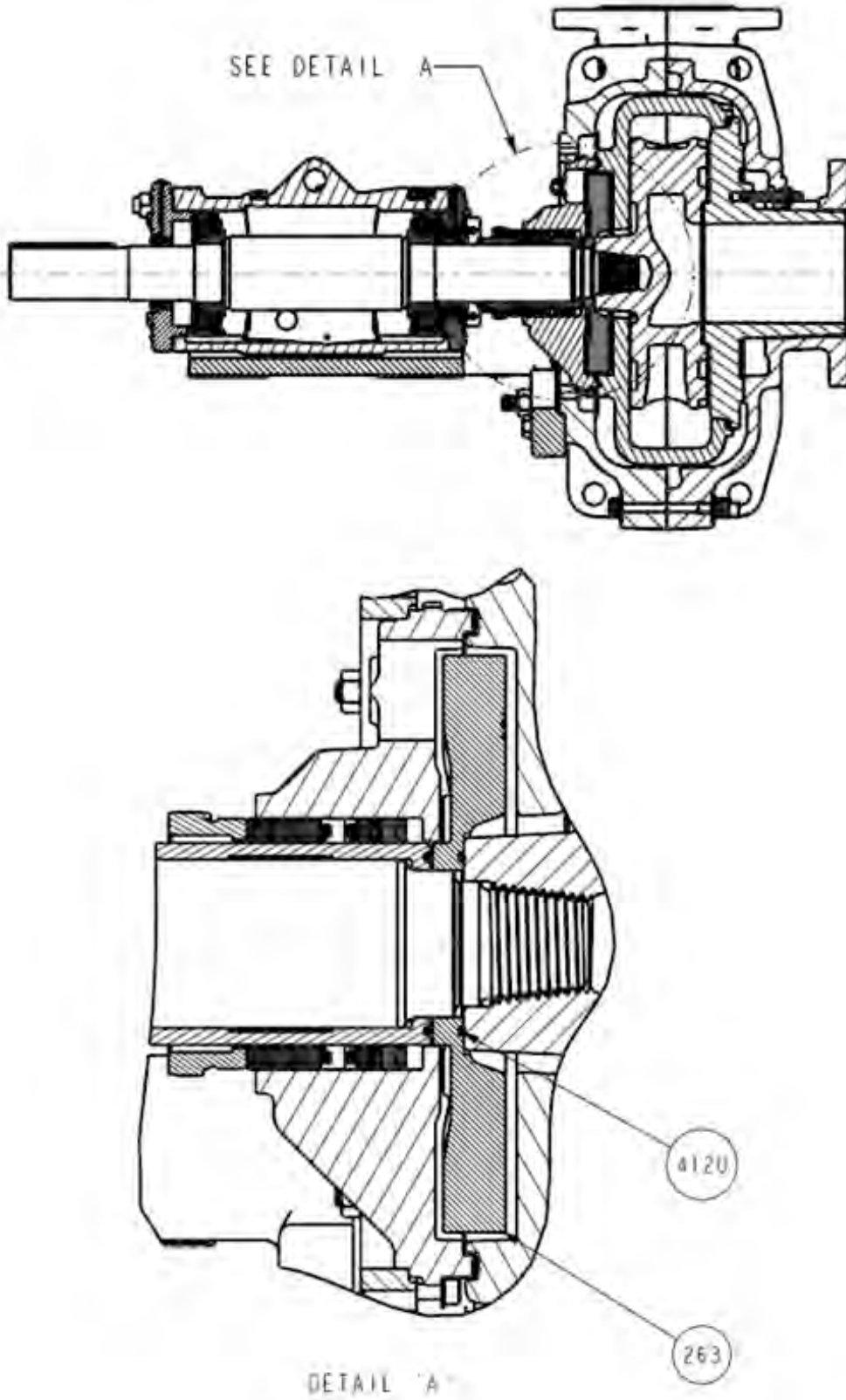

Figure 135: Dynamic seal option

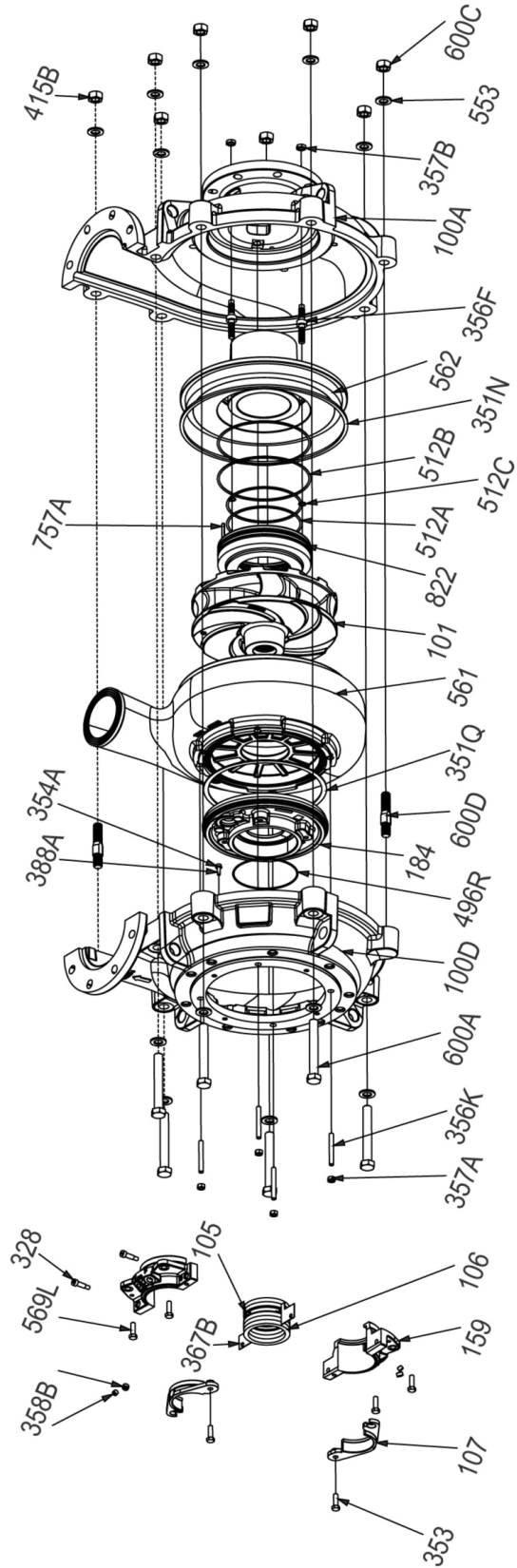

Figure 136: XHD Liquid End Metal Lined

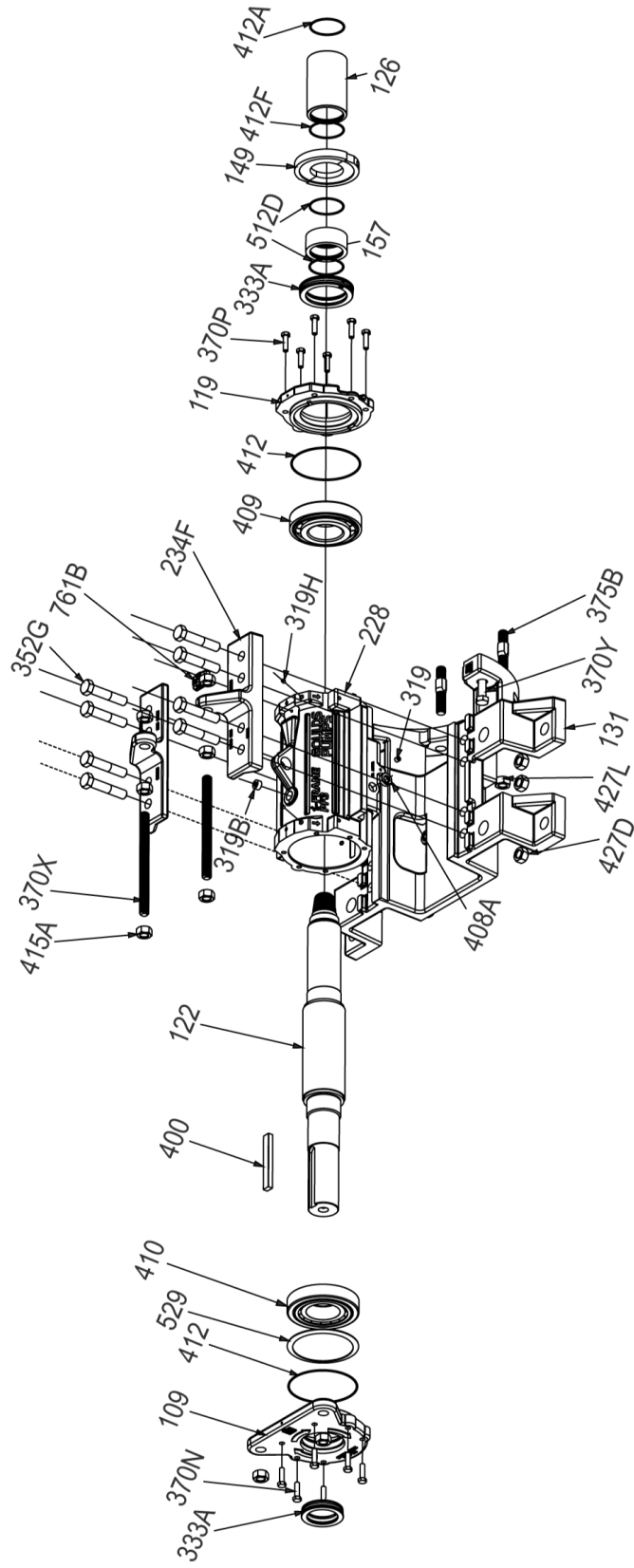

Figure 137: XHD Oil lube power end - Metal-lined

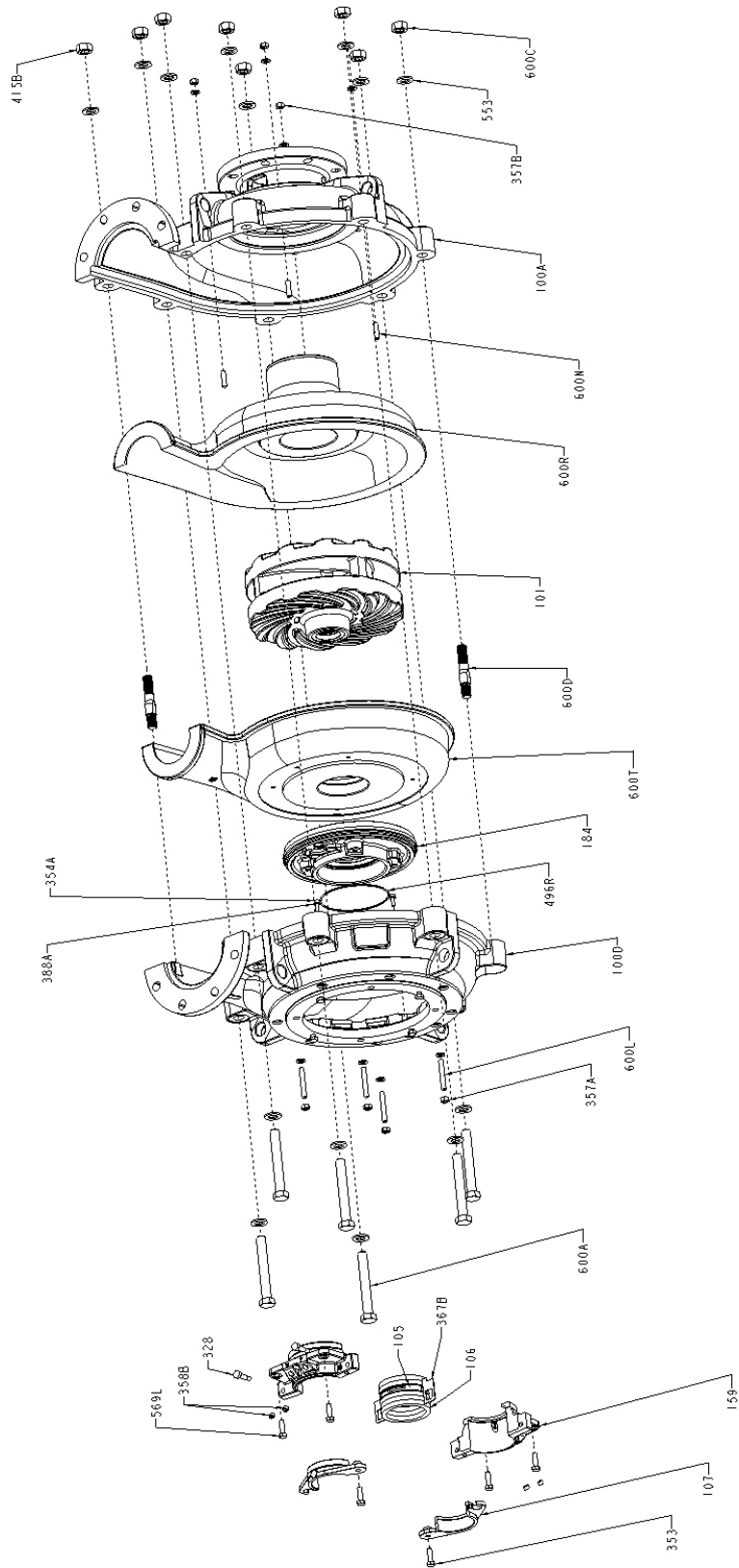

Figure 138: XHD Liquid End - Rubber-lined

9 Certification

9.1



EC-Declaration of Conformity

We herewith declare,

ITT Bornemann GmbH

Postfach 11 62, 31676 Obernkirchen, Germany
Fon +49 (0) 5724 390-0, Fax +49 (0) 5724 390-290,

that the machinery (centrifugal pump):

Order - No.:

Denomination:

Quantity:

Serial - No.:

Year of manufacture:

Is in conformity with the following EC-Directives, provided that the site conditions for the commissioning are met as specified in the engineering documents, in particular in the operation manual:

Machinery - Directive (2006/42/EC)

EMC - Directive (2014/30/EU)

Separate declarations of conformity are attached if marked below.

ATEX - Directive (2014/34/EU)

PED- Directive (2014/68/EU)

Harmonized standards used:

- | | |
|-----------------------|-------------------------------|
| • EN 349:1993+A1:2008 | • EN 12162:2001+A1:2009 |
| • EN 14120:2015 | • EN ISO 12100:2010 |
| • EN 13732-1:2008 | • EN 809:1998+A1:2009+AC:2010 |

Obernkirchen, date:

Managing Director

Technical Manager





UKCA-Declaration of Conformity

We herewith declare,

ITT Bornemann GmbH

Postfach 11 62, 31676 Obernkirchen, Germany
Fon +49 (0) 5724 390-0, Fax +49 (0) 5724 390-290,

that the machinery (centrifugal pump):

Order - No.: ...

Denomination: ...

Quantity: ...

Serial - No.: ...

Year of manufacture: ...

Is in conformity with the following EC-Directives, provided that the site conditions for the commissioning are met as specified in the engineering documents, in particular in the operation manual:

Supply of Machinery (Safety) Regulations 2008 No 1597

ECR - Directive (2016 No. 1091)

Separate declarations of conformity are attached if marked below.

UKEX - Directive (2016 No. 1107)

PESR- Directive (2016 No 1105)

Designated standards used:

- | | |
|-----------------------|-------------------------------|
| • EN 349:1993+A1:2008 | • EN 12162:2001+A1:2009 |
| • EN 14120:2015 | • EN ISO 12100:2010 |
| • EN 13732-1:2008 | • EN 809:1998+A1:2009+AC:2010 |

Obernkirchen, date:

Managing Director

Technical Manager





EC-Declaration of Incorporation

According to directive on machinery 2006/42 EC appendix II B

We herewith declare,

ITT Bornemann GmbH
 Postfach 11 62, 31676 Obernkirchen, Germany
 Fon +49 (0) 5724 390-0, Fax +49 (0) 5724 390-290,

that the incomplete machinery(centrifugal pump):

Order - No.:

Denomination:

Quantity:

Serial - No.:

Year of manufacture:

Conforms to the following basic requirements of the directive on machinery (2006/42/EC): appendix I, Article 1.1.2, 1.1.3, 1.1.5, 1.3.2, 1.3.3, 1.3.4, 1.3.7 and 1.7.3.

Harmonized standards used:

<ul style="list-style-type: none"> • EN 13732-1:2008 	<ul style="list-style-type: none"> • EN 12162:2001+A1 :2009 • EN ISO 12100:2010 • EN 809:1998+A1:2009+AC:2010
---	--

The commissioning is prohibited until it has been established, that the machinery, into which the above mentioned machinery is to be installed, complies with the Directive machinery (2006/42/EC).

We also declare that the relevant technical documentation for this incomplete machine was prepared according to appendix VII, Part B and commit ourselves to provide them in copy on demand to the market surveillance authorities.

Obernkirchen, date:

Managing Director

Technical Manager





UKCA-Declaration of Incorporation

According to **Supply of Machinery (Safety) Regulations 2008 No 1597**

We herewith declare,

ITT Bornemann GmbH

Postfach 11 62, 31676 Obernkirchen, Germany
Fon +49 (0) 5724 390-0, Fax +49 (0) 5724 390-290,

that the incomplete machinery(centrifugal pump):

Order - No.:

Denomination:

Quantity:

Serial - No.:

Year of manufacture:

Conforms to the following basic requirements of the directive on Machinery (Safety) Regulations 2008 No 1597: Annex I, Article 1.1.2, 1.1.3, 1.1.5, 1.3.2, 1.3.3, 1.3.4, 1.3.7 and 1.7.3.

Designated standards used:

- | | |
|---|--|
| <ul style="list-style-type: none"> • EN 13732-1:2008 | <ul style="list-style-type: none"> • EN 12162:2001+A1 :2009 • EN ISO 12100:2010 • EN 809:1998+A1:2009+AC:2010 |
|---|--|

The commissioning is prohibited until it has been established, that the machinery, into which the above mentioned machinery is to be installed, complies with the machinery directive (2008 No 1597).

We also declare that the relevant technical documentation for this incomplete machine was prepared according to appendix VII, Part B and commit ourselves to provide them in copy on demand to the market surveillance authorities.

Obernkirchen, date:

Managing Director

Technical Manager



10 Other Relevant Documentation or Manuals

10.1 For additional documentation

For any other relevant documentation or manuals, contact your ITT representative.

11 Local ITT Contacts

11.1 Regional offices

Region	Address	Telephone	Fax
North America (Headquarters)	ITT - Goulds Pumps 240 Fall Street Seneca Falls, NY 13148 USA	+1 315-568-2811	+1 315-568-2418
Houston office	12510 Sugar Ridge Boulevard Stafford, TX 77477 USA	+1 281-504-6300	+1 281-504-6399
Los Angeles	ITT - Goulds Pumps 880 W. Crowther Ave Placentia, CA 92870 USA	+1 562-908-4125	+1 562-695-8523
Asia Pacific	ITT Fluid Technology Asia Pte Ltd 1 Jalan Kilang Timor #04-06 Singapore 159303	+65 627-63693	+65 627-63685
Asia Pacific	ITT Goulds Pumps Ltd 35, Oksansandan-ro Oksan-myeon, Heungdeok-gu, Cheongju-si, Chungcheongbuk-do 28101, Rep. of KOREA	+82 234444202	
Europe	ITT Bornemann GmbH Industriestrasse 2, 31683 Obern- kirchen, Germany	+49 5724 390 2340	+49 5724 390 290
Latin America	ITT - Goulds Pumps Camino La Colina # 1448 Condominio Industrial El Rosal Huechuraba Santiago 8580000 Chile	+562 544-7000	+562 544-7001
Middle East and Africa	ITT - Goulds Pumps Achileos Kyrou 4 Neo Psychiko 115 25 Athens Greece	+30 210-677-0770	+30 210-677-5642

**Visit our website for the latest version of
this document and more information:**
<http://www.gouldspumps.com>



ITT Goulds Pumps Inc.
240 Fall Street
Seneca Falls, NY 13148
USA

Form IOM.XHD-en-US.2023-12